

(19) World Intellectual Property
Organization
International Bureau



(43) International Publication Date
21 October 2004 (21.10.2004)

PCT

(10) International Publication Number
WO 2004/090438 A1

(51) International Patent Classification⁷: **F24J 2/30**

(21) International Application Number:
PCT/DK2004/000257

(22) International Filing Date: 7 April 2004 (07.04.2004)

(25) Filing Language: English

(26) Publication Language: English

(30) Priority Data:
PA 200300543 9 April 2003 (09.04.2003) DK

(71) Applicant and

(72) Inventor: **SKOVBJERG, Erik, Villum** [DK/DK];
Skovbjergvej 7, DK-7400 Herning (DK).

(74) Agent: **PATRADE A/S**; Fredens Torv 3A, DK-8000
Århus C (DK).

(81) Designated States (unless otherwise indicated, for every
kind of national protection available): AE, AG, AL, AM,

AT, AU, AZ, BA, BB, BG, BR, BW, BY, BZ, CA, CH, CN,
CO, CR, CU, CZ, DE, DK, DM, DZ, EC, EE, EG, ES, FI,
GB, GD, GE, GH, GM, HR, HU, ID, IL, IN, IS, JP, KE,
KG, KP, KR, KZ, LC, LK, LR, LS, LT, LU, LV, MA, MD,
MG, MK, MN, MW, MX, MZ, NA, NI, NO, NZ, OM, PG,
PH, PL, PT, RO, RU, SC, SD, SE, SG, SK, SL, SY, TJ, TM,
TN, TR, TT, TZ, UA, UG, US, UZ, VC, VN, YU, ZA, ZM,
ZW.

(84) Designated States (unless otherwise indicated, for every
kind of regional protection available): ARIPO (BW, GH,
GM, KE, LS, MW, MZ, SD, SL, SZ, TZ, UG, ZM, ZW),
Eurasian (AM, AZ, BY, KG, KZ, MD, RU, TJ, TM), Euro-
pean (AT, BE, BG, CH, CY, CZ, DE, DK, EE, ES, FI, FR,
GB, GR, HU, IE, IT, LU, MC, NL, PL, PT, RO, SE, SI, SK,
TR), OAPI (BF, BJ, CF, CG, CI, CM, GA, GN, GQ, GW,
ML, MR, NE, SN, TD, TG).

Published:
— with international search report

For two-letter codes and other abbreviations, refer to the "Guid-
ance Notes on Codes and Abbreviations" appearing at the begin-
ning of each regular issue of the PCT Gazette.

(54) Title: SOLAR COLLECTOR AND METHOD FOR ITS OPERATION

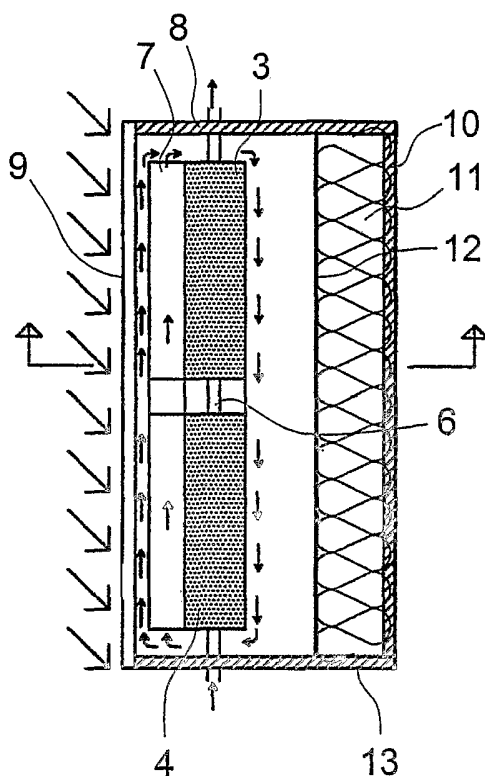

(57) **Abstract:** The invention concerns a method for utilising solar en-
ergy and a solar collector containing a box (1) with sides (14, 15) and a
bottom (13), where the top of the box (2) is formed by glass (9), where
the box (2) includes at least a first panel (3) for absorbing solar energy ,
where the first panel (3) has a front side and a rear side, where the front
side of the panel (3) faces the glass (9) of the solar collector, where the
panel (3) is flowed through by a first medium, where the first medium
is conducting the absorbed energy to a consumer or to an energy store.
The solar collector contains a second medium, where at least the front
side of the panel (3) contains heat exchanger surfaces (7) that are flowed
through by the second medium, by convection, and where the second
medium deposits power to the panel.

WO 2004/090438 A1

Solar Collector and Method for Its Operation

The present invention concerns a solar collector containing a box with sides and a bottom, where the top of the box is formed by glass, where the box includes at least a first panel for absorbing solar energy, where first panel has a front side and a rear side, where the front side of the panel faces the glass of the solar collector, where the panel is flowed through by a first medium, where the first medium is conducting the absorbed energy to a consumer or to an energy store.

The invention also concerns a method for utilising solar energy, where a first medium flows through at least a first panel absorbing energy from direct irradiation, where the panel is disposed behind glass in an insulated unit, and where the first medium is conducted to a consumer and back to the panel.

From US 4,423,718 is known an evacuated solar collector, where inside the solar collector there are provided a number of longitudinal pipes containing a liquid to be heated. These pipes are fastened to two transverse pipes at each end in such a way that the enclosed gas or air is passing freely around the longitudinal pipes. By this invention is achieved that pipes and manifold are placed in a subpressure chamber whereby pipes and manifold are insulated.

By putting a solar collector under subpressure, insulation is attained, but there will be loss of efficiency by the solar collector only absorbing radiation heat. The heat loss occurring by infrared radiation is partially lost because there is very bad heat conduction in the chamber with subpressure, where there is low pressure and almost no convection flow that can conduct energy around internally of the solar collector.

DE 43 38 520 A1 discloses an evacuated solar collector, built up as a chamber constructed of two curved halves, where an underpressure in the chamber results in compressive forces on the outer side of the chamber, pressing the two halves against each other, where one of the chamber sides is formed by glass, and where the chamber contains an absorption plate to which is fastened pipes flowed through by a medium.

This solar collector will only operate efficiently where strong direct radiation occurs. With weak or diffused sunlight, the solar collector will be poorly suited for absorbing solar energy.

5

US 4,172,442 concerns a solar collector system with high energy absorption by simultaneously heating a gas and a fluid medium flowing through the solar collector. The gas flows in a narrow passage at the sun side of the duct for the fluid medium. Exposure time for gas and fluid medium is regulated with an independent thermostatic control. The hot gas and the heated fluid medium may be used for energy supply to buildings and heating of tap water. Both the fluid medium and the gas are conducted out from the solar collector through pipes or ducts, and heat exchange occurs outside the solar collector itself.

15 A solar collector of this type is only suitable with the presence of strong incident solar radiation. If the sun is standing low, heating of gas will largely occur by simultaneous cooling of the fluid medium. At the same time, the gas is to flow into and out of the solar collector, where the gas flow will presuppose using means for establishing a gas flow.

20

It is the purpose of the invention to achieve an efficient solar collector which is particularly suited for upright mounting, where the solar collector is utilising weak diffused light optimally.

25 This may be achieved with a solar collector as specified in the introduction, if the solar collector may contain a second medium, where at least the front side of the panel may contain heat exchanger surfaces that can be flowed through by the second medium, where the second medium can flow around heat exchanger surfaces by convection, and where the second medium deposits power on the panel.

30

Hereby may be achieved that the heat exchanger surfaces can be heated by solar radiation and that heat exchanger surfaces can deposit some of their energy in the sec-

ond medium which, due to a desired convection flow, passes the heat exchanger surfaces. Depending on the temperature of the heat exchanger surfaces, the second medium absorbs from or releases power to the heat exchanger surfaces. Close to the bottom of the solar collector, a solar collector will often be coldest, and heat exchanger surfaces can absorb energy from the second medium where the heat exchanger surfaces can give off power to the panel. Absorbing energy from the second medium can result in a considerable increase in the efficiency of the solar collector.

The back side of the panel can contain heat exchanger surfaces. Hereby may be achieved that the back side of the panel, which is to be colder than the front side, can absorb the energy supplied to the heat exchanger surface on the front side of the panel. Thereby, energy may be utilised at the front side as well as the back side of the panel, and additional amplification of the efficiency of the solar collector may be attained.

The panel can be disposed behind an absorption plate where between absorption plate and panel there may be found at least one duct flowed through by the second medium, where the absorption plate on the forward facing side may contain a decoration. Hereby may be achieved that all direct solar radiation is absorbed by absorption plate, where the energy of the absorption plate is given off to the surrounding second medium which subsequently supplies power to the panel by means of the heat exchanger surfaces. Direct heat conduction from absorption plate to the panel may occur if a number of partitioning surfaces are formed in the duct formed between panel and absorption plate, where the partitioning surfaces have sufficient transverse profile in order to transmit heat. Because the absorption plate can be designed with a plane surface facing forwards, the surface may be decorated, and the solar collector may appear as a piece of art. Because the solar collector will operate with high efficiency even when mounted vertically, solar collectors may form direct part of building fronts. Front decoration can be solar collectors. In practice, other colours than black will absorb about the same power, however, the use of very light colours should be avoided. Thereby, an artist may colour solar collectors without substantial loss of efficiency.

The panel may have heat exchanger surfaces in the form of external ducts having

trapezoidal cross-section, where the longest side of the cross-section is common with the panel. Hereby may be achieved that closed ducts are formed at the outer sides of the panel, where convection flow can occur in the ducts. If the solar collector is raised to a large angle relative to a horizontal plane, strong convectational flow may occur in the closed ducts. Hereby, energy may be exchanged between the front side of the ducts that is impinged by the direct solar radiation, and the back side of the ducts which can be formed by the surface of the panel. Simultaneously, the second medium can flow up and out of the ducts, after which the second medium can supply further energy to the back side of the panel, where cooling will make the second medium seek towards the bottom of the solar collector.

The sides of the cross-section of the ducts can have an angle of at least 30 degrees relative to the surface of the panel. Hereby may be achieved a steep profile where the formed ducts have a large cross-sectional area with limited material consumption.

The solar collector can be disposed at an angle of at least 45 degrees relative to horizontal plane. Hereby may be achieved that the solar collector becomes more efficient as convectational flow in the second medium in the solar collector requires that the solar collector is upright, where a vertical disposition will be optimal for the convection flow, but a lesser angle may be optimal for direct incident solar radiation.

The external ducts of the panel can cover 75% of the panel front side at the most. Hereby may be achieved that direct incident solar radiation can occur directly to the panel, which is heated thereby.

The solar collector may contain at least one heat exchanger that cools the second medium of the solar collector, where the heat exchanger may be flowed through by the first medium which may be heated in the heat exchanger, where the first medium from the heat exchanger may be flowing to the inlet of the panel. Hereby may be achieved that the second medium can be cooled efficiently, where the cooled medium automatically becomes heavier and will seek towards the bottom of the panel, from which the medium can be reheated, possibly by the passing of a duct, where the medium seeks

towards the top of the panel. If the inlet of the heat exchanger for the second medium occurs at the top of the solar collector, the internal flow rate for the second medium in the solar collector may be substantially increased, and a further increase of the efficiency of the solar collector can be achieved.

5

The solar collector can contain a first panel for absorbing radiation energy and convection energy from the heated second medium, where the solar collector can contain a second panel that may be disposed behind the first panel, where the second panel contains heat conducting surfaces for absorbing convection energy from the heated second medium, where the second panel is flowed through by the first medium that also flows through the first panel, where the panels are serially connected as to flow with regard to the first medium, where the second panel has connection to an inlet for the first medium, where the second panel has connection to an outlet for the first medium. Hereby may be achieved that the second medium can supply heat to the second panel which may be colder than the first panel. Cooling of the second medium will make the medium heavier, and the internal flow of the second medium is increased, whereby the efficiency of the solar collector is increased.

10

15

The panel may be disposed behind an absorption plate, where between absorption plate and panel there is provided at least one duct which is flowed through by the second medium, which absorption plate on the forward facing side contains electric solar panels. In this way electric power can be collected and simultaneously the first and the second medium is heated. By placing electric solar panels on the front surface of the absorption plate heat generated in the electric solar panels are conducted to the panel by the flowing second medium and by direct heat transmission through the sidewalls of the ducts. This leads to a lower operating temperature for the electric solar power panels and to a higher electric energy production.

20

25

The top of the box might be formed by a glass pane, which glass pane comprises at least one film, which film is converting solar energy into electric energy. In this way can be formed an electric solar power element with no mechanical contact to the panel

30

below. The electric solar panel does only reduce the heating of the panels below a little, but the circulating media under the pane and in the panels reduce the temperature at the electrical solar power elements.

5

The invention may also include a method as the one described in the introduction, if the method includes that at least the first panel may contain means for absorbing energy from a convection flow in a second medium that may surround the panel, where
10 the convection flow may occur in a closed circuit delimited by the solar collector, where the panel may contain heat conducting surfaces at least at the front side of the of the panel for absorbing energy from the second medium. Hereby may be achieved a more efficient utilisation of solar energy in relation to prior art methods. The method is particularly efficient for utilising weak and diffuse solar radiation often appearing at
15 high latitudes.

Absorbing energy from the second medium may occur in a heat exchanger, where the energy of the second medium is transferred to the first medium. Hereby may be achieved a very efficient cooling of the second medium, where the first medium is
20 simultaneously heated. By letting the first medium pass through the heat exchanger before supplying the first medium to the panel, preheating of the first medium can be achieved before the medium is further heated in the panel. The second medium will, after cooling in the heat exchanger, increase its weight and seek towards the bottom of the solar collector, whereby the internal flow in the solar collector is increased. With
25 the specified method, there may be achieved a very high efficiency for solar collectors that are used at high latitudes, where a solar collector is to be raised due to the angle of the sun.

The heat exchanger may advantageously have access to the second medium at the upper
30 side of the panel. Hereby may be achieved that the second medium is applied where the medium temperature is highest. Thereby, a heat exchanger can be disposed arbitrarily relative to the panel. If the outlet of the heat exchanger has connection to a

volume behind the panel, the medium will flow towards the bottom and be reheated. Hereby, the natural flow in a solar collector may be increased.

In the following, the invention is described from drawings, where:

5

Fig. 1 shows a possible embodiment of a solar collector seen from the front,

Fig. 2 shows a longitudinal section through the same solar collector,

Fig. 3 shows a transverse section of the same solar collector,

10 Fig. 4 shows a longitudinal section through a first alternative embodiment of the invention,

Fig. 5 shows a transverse section through the first alternative embodiment of the invention,

Fig. 6 shows a longitudinal section through a second alternative embodiment of a solar collector,

15 Fig. 7 shows a transverse section through the second alternative embodiment of the invention,

Fig. 8 shows a detail of a fourth alternative embodiment of a solar collector,

Fig. 9 shows a detail of the lower part of Fig. 7,

Fig. 10 shows a section through a third alternative embodiment of the invention.

20 Fig. 11 shows a section through an embodiment of the invention comprising electric solar panels.

Fig. 12 shows a front view of a solar collector comprising electric solar panels.

25 Fig. 1 shows a possible embodiment of a solar collector 1 as seen from the front where the solar collector contains a box 2 in which panels 2 and 3 are found. The panels 2 and 3 are connected by connections 5 and 6 so that panels 2 and 3 are built together, where the panels are communicating with a not shown inlet and outlet. The panels 2 and 3 contain heat conducting surfaces in the form of ducts 7. The solar collector 1 has two inlets 21 for the first medium and has two outlets 22 for the first medium.

30

Fig. 2 shows a longitudinal section through the solar collector 1, where the panels 3 and 4 are found. The panels are shown with ducts 7. The solar collector 1 has a top

plate 8 and a glass plate 9, where the solar collector 1 has rear plate 10 and a bottom plate 13. The solar collector 1 contains an insulation material 11, where a reflector 12 is disposed between insulation 11 and panels 3 or 4.

5 Fig. 3 shows a cross-section of the solar collector 1. The panel 4 with ducts 7 is shown under the glass plate 9, where the solar collector contains insulation 11 under a reflector 12, and where the solar collector has sides 14 and 15.

Solar collectors 1 shown in Figs. 1 – 3 operate in that sun rays pass through the glass
10 plate 9 and impinge on the panels 3 and 4, which are thereby heated. The sun rays also impinge on the ducts 7 at the outer side of the ducts 7. The ducts 7 are heated, and the ducts 7 yield heat by radiation and by heating the ambient second medium. The second medium becomes lighter by heating, and the medium rises up under continuing heating until the second medium reaches the top of the panel. The medium will here,
15 due to continued convection flow, be forced to the rear side of the panel, where the second medium is cooled by contact with the panel 3, whereby the second medium becomes heavier during continuous cooling, and the medium sinks down to the bottom 13 of the solar collector, where the second medium may repeat its flow. By using convection flow for energy transport, the solar collector can attain a very high efficiency,
20 also in diffuse sun radiation with the sun standing low.

Fig. 4 shows a longitudinal section through the solar collector 101, where panels 103 and 104 are provided. The panels are shown with ducts 107. The solar collector 101 has a top plate 108 and a glass plate 109, where the solar collector 101 has a rear plate
25 110 and a bottom plate 113. The solar collector 101 contains an insulation material 111 where a reflector 112 is disposed between insulation 111 and panels 103 or 104. Panels 103 and 104 contain ducts 116 at their rear sides.

Fig. 5 shows a second possible embodiment of the solar collector, where Fig. 5 shows
30 a cross-section through the solar collector 101. The panel 104 with ducts 107 are shown under the glass plate 109, where the solar collector contains insulation 111 under a reflector 112, where the solar collector has sides 114 and 115. The solar collector

differs from the solar collector shown on Figs. 1 – 3 by containing ducts 116 at the rear sides of the panels 103 and 104.

5 Use of ducts 116 at the rear side of the panels means that the heated second medium is provided access to a far larger area that may conduct heat into the panels. Thereby, the efficiency is further increased.

10 Fig. 6 shows a longitudinal section through the solar collector 201, where the panels 203 and 204 are provided. The panels are shown with ducts 207. The solar collector 201 has a top plate 208 and a glass plate 209, where the solar collector 201 has a rear plate 210 and a bottom plate 213. The solar collector 201 contains an insulation material 211 where a reflector 212 is disposed between insulation 211 and panels 203 and 204. The panels 203 and 204 contain ducts 216 at their rear sides. The solar collector contains the second panel 217 containing ducts 218 and 219, where the panel 204 contains heat conducting surfaces 220. The panel 217 is shown with a possible inlet for the first medium 211, where the panel 203 is shown with a possible outlet 222 for the first medium. An internal connection 223 for the first medium is shown between the panels 217 and 204.

20 Fig. 7 shows a third possible embodiment of the solar collector, where Fig. 7 shows a cross-section through the solar collector 201. The panel 204 with ducts 207 is shown under the glass plate 209, where the solar collector contains insulation 211 under a reflector 212, where the solar collector has sides 214 and 215. The solar collector contains ducts 116 at the rear sides of the panels 103 and 104. The solar collector contains a second panel 217 disposed behind the first panel 204. The second panel 217 contains ducts 218 and 219.

30 By flowing towards the top of the panels, the second medium, which is heated at the front side of the panels 203 and 204, will come into contact with the panel 217 that is receiving cooled first medium through inlet 221. The second medium is cooled while the first medium is heated. Due to cooling by contact with panel 217 or ducts 218 and 219, the second medium sinks down against heat conducting surfaces which are con-

ected to the panel 204, whereby heat conduction occurs from the second medium to the panel 204.

Fig. 8 shows a section through a third possible embodiment of the solar collector, where there is shown a glass plate 309 and a panel 303 which is surrounded by ducts 317 and 318, where between glass plate 309 and ducts 317 there is provided an adsorption plate 321.

Solar radiation will impinge on the plane adsorption plate 321, where the sides of the ducts 317 are conducting heat to the panel 303. The second medium will flow in and between the ducts 317 where the second medium can exchange heat with the panels as previously described.

Fig. 9 shows a detailed section through the second embodiment of the invention. A glass plate 209 lies in front of a panel 204 containing ducts 207 at the front side, where the panel 204 contains heat conducting surfaces 220 at the rear side.

Fig. 10 shows a longitudinal section through the solar collector 401, where the panels 403 and 404 are found. The panels are shown with ducts 407. The solar collector 401 has a top plate 408 and a glass plate 409, where the solar collector 401 has a rear plate 401 and a bottom plate 413. The solar collector 401 contains an insulation material 411, where a reflector 412 is disposed between insulation 411 and panels 403 and 404. The panels 403 and 404 contain ducts 416 at their rear side. The solar collector contains a heat exchanger 424 where the panel 404 contains heat conducting surfaces 420. The heat exchanger 424 is shown with a possible inlet for the first medium 421, where the panel 403 is shown with a possible outlet 422 for the first medium. An internal connection 423 for the first medium is shown between the panels 417 and 404.

The use of heat exchanger 424 implies very effective cooling of the second medium which may leave the heat exchanger at a temperature which is only few degrees over the inlet temperature for the first medium. Hereby, the energy content in the second medium is utilised optimally, and the internal convection flow in the solar collector is

considerably increased. Thereby is achieved a very high efficiency for the invention. In an alternative embodiment, the heat exchanger can be disposed outside the solar collector itself, and the second medium can be conducted through ducts back and forth to the heat exchanger.

5

Fig. 11 shows a section through an embodiment of the invention comprising electric solar panels. Where there is shown a panel 503 which is surrounded by ducts 517 and 518, where in front of the ducts 517 there is provided an adsorption plate 521. The adsorption plate contains on the front side electric solar panel 525 for production of electric power. The adsorption plate is cooled by the circulating second media and the temperature of the electric solar panels is reduced. Increasing temperature of electric solar power elements leads to decreasing power production. In this way cooling of the electric panels is increasing the power production.

15 Fig 12 shows a front view of a solar collector comprising electric solar panels 525.

The heat exchanger may be cooled a second medium circuit for the first medium, particularly the heat exchanger can be suited for heating tap water, where the tape water is to be further heated subsequently, which either can occur with the normal circuit of the solar collector, or with other known means for heating.

20

Advantageously, there may be used a pump for increasing through flow of the second medium through the heat exchanger.

25

A solar collector with glass and a water-filled cooling element operates by incident sun light passing through the glass without appreciable energy loss, and the light also passes through air almost without loss. When the light impinges on cooling element or a rear or side wall, some of the power of the sunlight is deposited on the surface which is then heated. The heated surface emits light with considerably lower wavelength, a wavelength with only can pass the glass to a lesser extent, the glass partly acting as a mirror. Heating of the ambient air occurs simultaneously with the hot surfaces emit-

30

ting light. Heated air rises, so an air flow will be initiated. Utilisation of the heated air can result in a substantial increase of the efficiency of a solar collector.

List of reference numbers:

| | | |
|----|-----|-------------------------|
| 5 | | |
| | 1 | solar collector |
| | 2 | box |
| | 3 | panel |
| | 4 | panel |
| 10 | 5 | connection |
| | 6 | connection |
| | 7 | duct |
| | 8 | top |
| | 9 | glass plate |
| 15 | 10 | rear plate |
| | 11 | insulation |
| | 12 | reflector |
| | 13 | bottom plate |
| | 14 | side plate |
| 20 | 15 | side plate |
| | 21 | inlet for first medium |
| | 22 | outlet for first medium |
| | 101 | solar collector |
| 25 | 103 | panel |
| | 104 | panel |
| | 107 | duct |
| | 108 | top plate |
| | 109 | glass plate |
| 30 | 110 | rear plate |
| | 111 | insulation |
| | 112 | reflector |

| | | |
|----|-----|--------------------------------------|
| | 113 | bottom plate |
| | 114 | side plate |
| | 115 | side plate |
| | 116 | duct |
| 5 | | |
| | 201 | solar collector |
| | 203 | panel |
| | 204 | panel |
| | 207 | duct |
| 10 | 208 | top plate |
| | 209 | glass plate |
| | 210 | rear plate |
| | 211 | insulation |
| | 212 | reflector |
| 15 | 213 | bottom plate |
| | 214 | side plate |
| | 215 | side plate |
| | 216 | duct |
| | 217 | panel |
| 20 | 218 | duct |
| | 219 | duct |
| | 220 | heat conducting surface |
| | 221 | inlet for first medium |
| | 222 | outlet for first medium |
| 25 | 223 | internal connection for first medium |
| | | |
| | 303 | panel |
| | 309 | glass plate |
| | 316 | duct |
| 30 | 317 | duct |
| | 321 | adsorption plate |

| | | | |
|----|-----|--------------------------------------|-----------|
| | 401 | solar collector | |
| | 403 | panel | |
| | 404 | panel | |
| | 407 | duct | |
| 5 | 408 | top plate | |
| | 409 | glass plate | |
| | 410 | rear plate | |
| | 411 | insulation | |
| | 412 | reflector | |
| 10 | 413 | bottom plate | |
| | 414 | side plate | |
| | 415 | side plate | |
| | 416 | duct | |
| | 418 | duct | |
| 15 | 419 | duct | |
| | 420 | heat conducting surface | |
| | 421 | inlet for first medium | |
| | 422 | outlet for first medium | |
| | 423 | internal connection for first medium | |
| 20 | 424 | heat exchanger | |
| | 501 | Solar collector | 503 panel |
| | 516 | duct | |
| | 517 | duct | |
| | 521 | adsorption plate | |
| 25 | 525 | Electric solar panels | |

CLAIMS

1. Solar collector (1, 101, 202, 401) containing a box (2) with sides (14, 15) and a bottom (13), where the box (2) includes at least a first panel (3, 103, 203, 303, 403, 503) for absorbing solar energy, where first panel (3, 103, 203, 303, 403, 503) has a front side and a rear side, where the front side of the panel faces the front of the solar collector (9, 109, 209, 309, 409), where the panel (3, 103, 203, 303, 403, 503) is flowed through by a first medium, where the first medium is conducting the absorbed energy to a consumer or to an energy store, **characterised in that** the box (2) contains a second medium, where at least the front side of the panel (3, 103, 203, 303, 403, 503) contains heat exchanger surfaces (7, 207, 317, 407, 517) that are flowed through by the second medium, the second medium flowing in a closed circuit which is delimited by the box (2), where the second medium flows around the heat exchanger surfaces (3, 103, 203, 303, 403, 503) by convection, where the second medium deposits power to the panel (3, 103, 203, 303, 403, 503) by heat exchanging.
2. Solar collector according to claim 1, **characterised in that** the top of the box is formed by glass (9, 109, 209, 309, 409).
3. Solar collector according to claim 1 or 2, **characterised in that** the rear side of the panel (3, 103, 203, 303, 403, 503) contains heat exchanger surfaces (116, 216, 316, 416, 516).
4. Solar collector according to claim 1- 3, **characterised in that** the panel (3, 103, 203, 303, 403, 503) is disposed behind an absorption plate (321, 521), where between absorption plate and panel there is provided at least one duct (317, 517) which is flowed through by the second medium, where the absorption plate (321, 521) on the forwards facing side contains decorations.
5. Solar collector according to any of claims 1 – 4, **characterised in that** the panel (3, 103, 203, 303, 403, 503) has heat exchanger surfaces in the shape of external panels (7, 107, 207, 317, 407, 517) with a trapezoidal cross-section, where the longest side of

the cross-section is common with the panel (3, 103, 203, 303, 403, 503).

5 6. Solar collector according to any of claims 1 – 5, **characterised in that** the sides of the cross-section of the ducts (7, 107, 207, 317, 407, 517) are disposed at an angle of at least 30 degrees relative to the surface of the panel (3, 103, 203, 303, 403, 503).

7. Solar collector according to any of claims 1 – 6, **characterised in that** the solar collector (1, 101, 201, 401, 501) is disposed at an angle of at least 45 degrees relative to a horizontal plane.

10

8. Solar collector according to any of claims 1 - 7, **characterised in that** the external ducts (7, 107, 207, 317, 407, 517) of the panel cover at the most 75% of the front side of the panel.

15 9. Solar collector according to any of claims 1 – 8, **characterised in that** the solar collector (1, 101, 201, 401) contains at least one heat exchanger (424) cooling the second medium of the solar collector, where the heat exchanger is flowed through by the first medium which is heated in the heat exchanger (424), where the first medium from the heat exchanger (424) is flowing to the inlet of the panel.

20

10. Solar collector according to any of claims 1 – 9, **characterised in that** the solar collector (1, 101, 201, 401) contains a first panel (3, 103, 203, 303, 403, 503) for absorbing radiation energy and convection energy from the heated second medium, where the solar collector (1, 101, 201, 401, 501) contains a second panel (217) disposed behind the first panel (3, 103, 203, 303, 403, 503), where the second panel (217) contains heat conducting surfaces (218, 219) for absorbing convection energy from the heated second medium, where the second panel (217) is flowed through by the first medium that also flows through the first panel (3, 103, 203, 303, 403, 503), where the panels (217) are serially connected as to flow with regard to the first medium, where
25
30 the second panel (217) has connection to an inlet (221) for the first medium, where the second panel has connection to an outlet (222) for the first medium.

11. Solar collector according to one of the claims 1-10, **characterized in that** the panel (3, 103, 203, 303, 403, 503) is disposed behind an absorption plate (521), where between absorption plate and panel there is provided at least one duct (517) which is flowed through by the second medium, which absorption plate (521) on the forward
5 facing side contains electric solar panels (525).

12. Solar collector according to one of the claims 1-10, **characterized in that** the top of the box is formed by a glass pane (9, 109, 209, 309, 409) which glass comprises at least one film, which film is converting solar energy into electric energy.
10

13. Method for utilising solar energy, where a first medium flows through at least a first panel (3, 103, 203, 303, 403, 503) absorbing energy from direct irradiation, where the panel (3, 103, 203, 303, 403, 503) is disposed in an insulated unit, where the first
15 medium is conducted to a consumer and back to the panel, **characterised in that** at least the first panel (3, 103, 203, 303, 403, 503) contains means for absorbing energy from a convection flow in a second medium surrounding the panel, where the convection flow occurs in a closed circuit delimited by the solar collector, where the panel contains heat conducting surfaces (7, 207, 407) at least at the front side of the of the
20 panel for absorbing energy from the second medium.

14. Method according to claim 11, **characterised in that** absorption of energy from the second medium occurs in a heat exchanger (424), where the energy of the second medium is transmitted to the first medium.
25

15. Method according to claim 11 or 12, **characterised in that** the heat exchanger (424) has inlet for the second medium at the upper side of the panel.

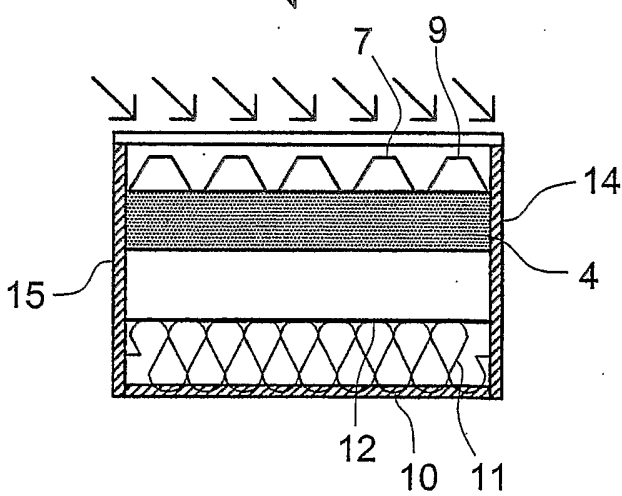
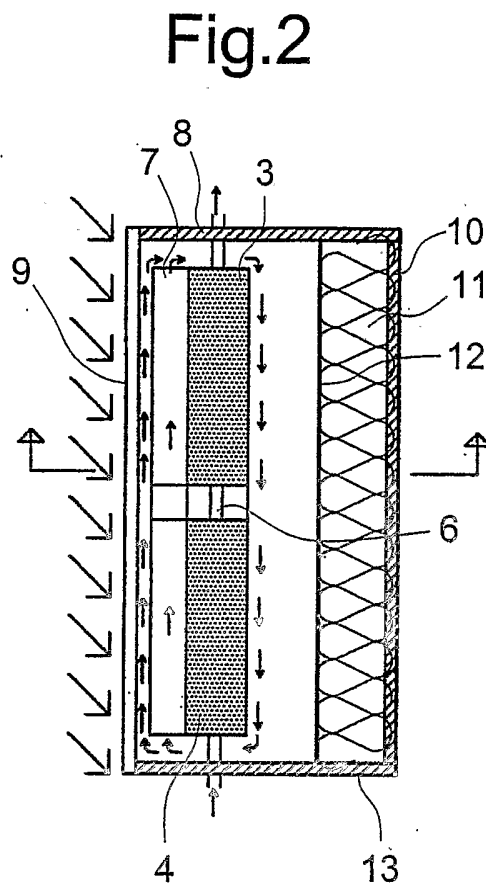
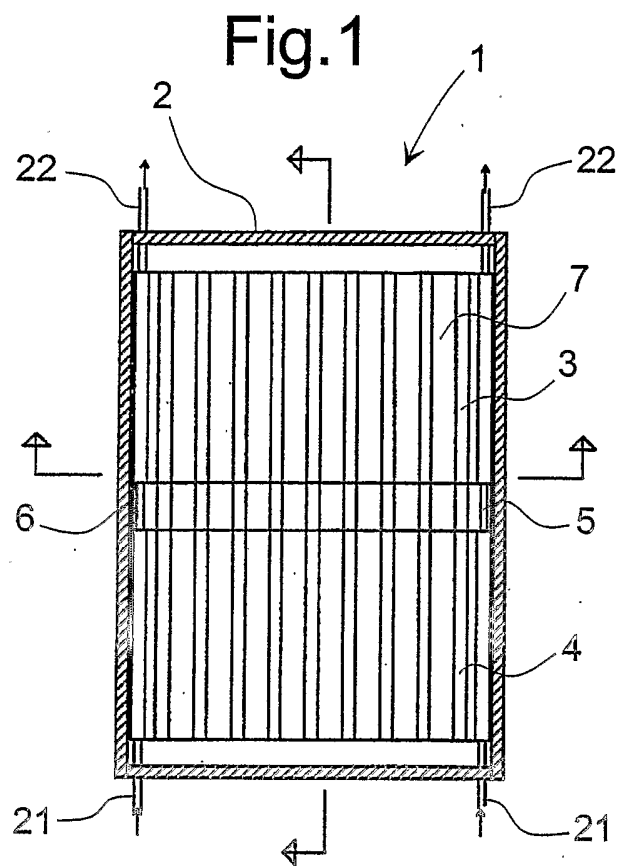

Fig.3

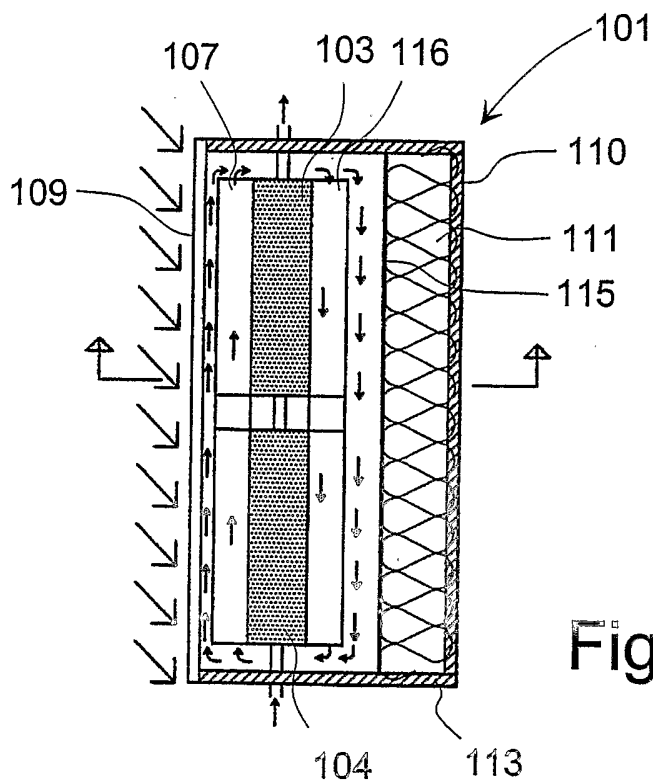
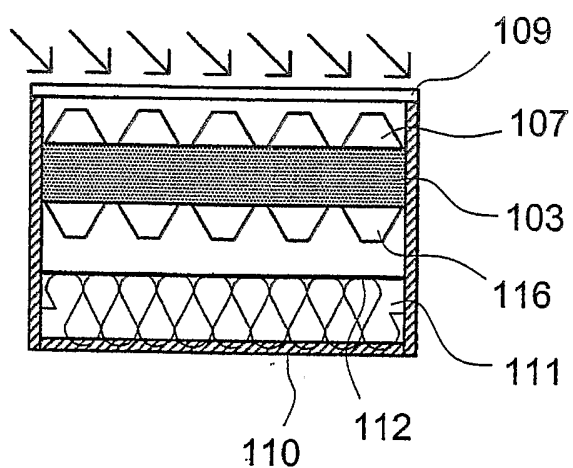

Fig. 4

Fig. 5



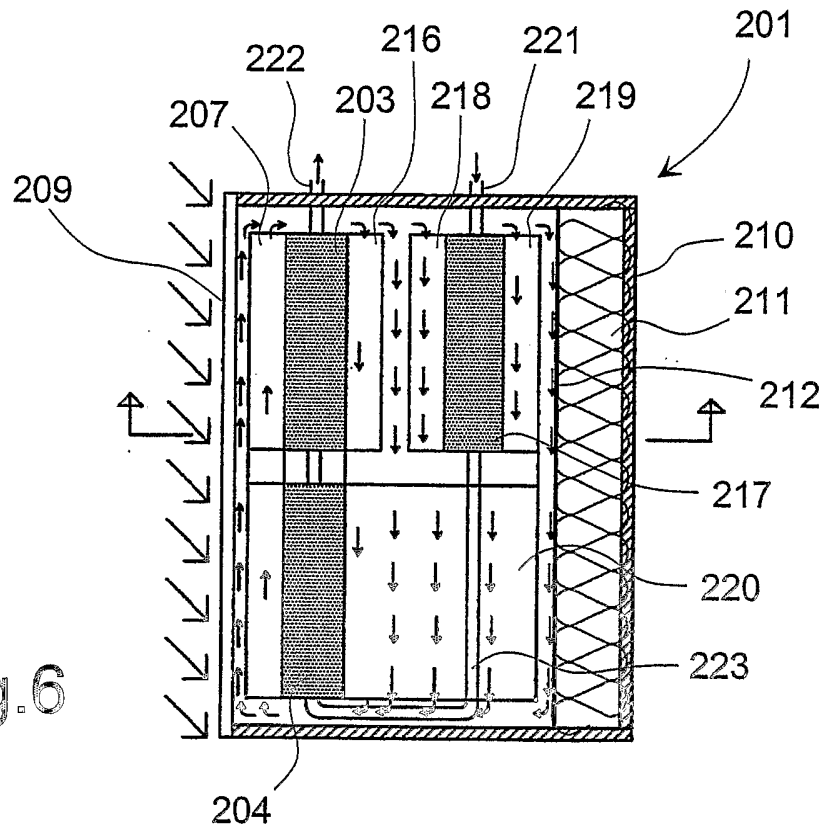

Fig. 6

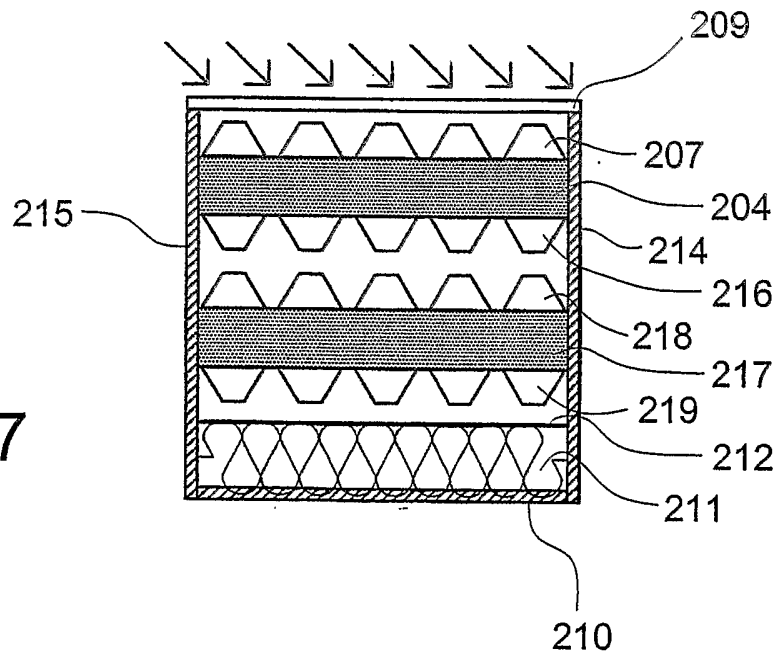

Fig. 7

4/6

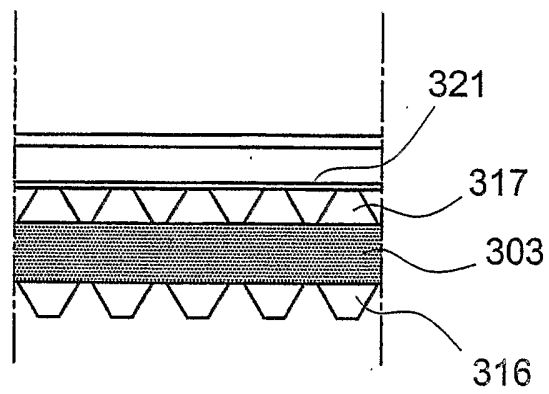

Fig.8

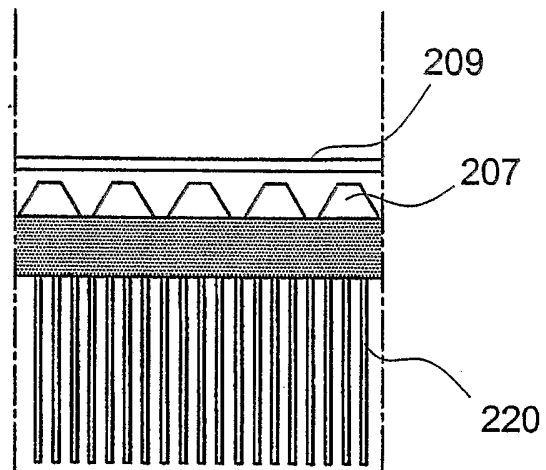

Fig.9

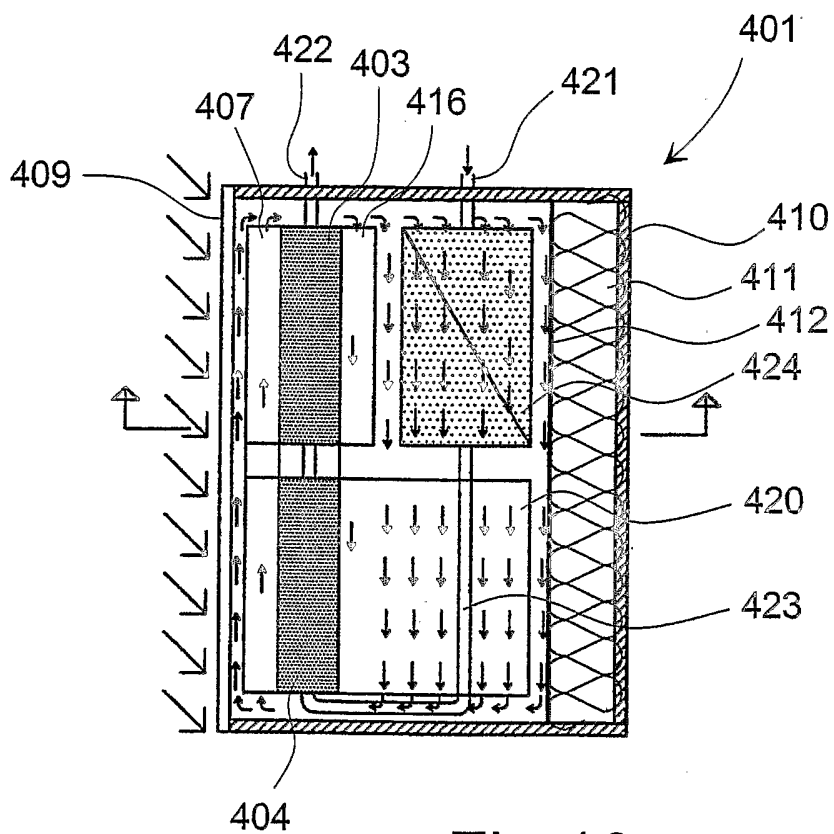

Fig.10

6/6

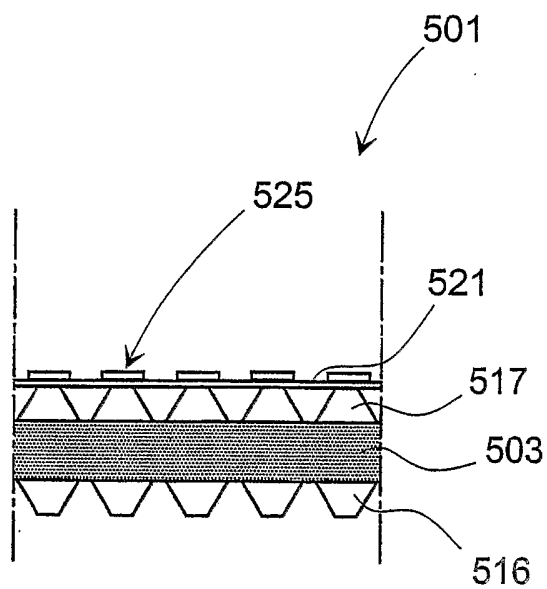

Fig.11

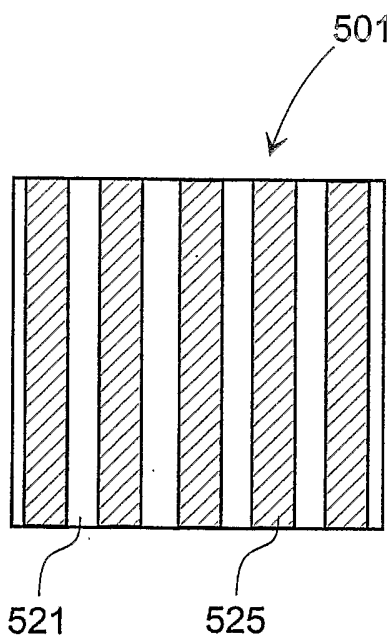

Fig.12

INTERNATIONAL SEARCH REPORT

 International Application No
 PCT/DK2004/000257

 A. CLASSIFICATION OF SUBJECT MATTER
 IPC 7 F24J2/30

According to International Patent Classification (IPC) or to both national classification and IPC

B. FIELDS SEARCHED

Minimum documentation searched (classification system followed by classification symbols)

IPC 7 F24J H01L

Documentation searched other than minimum documentation to the extent that such documents are included in the fields searched

Electronic data base consulted during the international search (name of data base and, where practical, search terms used)

EPO-Internal

C. DOCUMENTS CONSIDERED TO BE RELEVANT

| Category ° | Citation of document, with indication, where appropriate, of the relevant passages | Relevant to claim No. |
|------------|--|-----------------------|
| X | DE 198 24 027 A (LOEFFLER MICHAEL) 2 December 1999 (1999-12-02) | 1-3, 7, 9, 13-15 |
| Y | column 1, line 35 - column 2, line 47; figure 1 | 4-6, 12 |
| Y | US 4 309 983 A (BRILL ROBERT) 12 January 1982 (1982-01-12) column 3, line 64 - column 4, line 2; figure 4 | 4 |
| Y | US 4 282 860 A (KOIZUMI HISAO ET AL) 11 August 1981 (1981-08-11) figure 8 | 5, 6 |
| Y | US 4 400 577 A (SPEAR REGINALD G) 23 August 1983 (1983-08-23) abstract; compounds | 12 |
| | ----- -/-- | |

 Further documents are listed in the continuation of box C.

 Patent family members are listed in annex.

° Special categories of cited documents:

- *A* document defining the general state of the art which is not considered to be of particular relevance
- *E* earlier document but published on or after the international filing date
- *L* document which may throw doubts on priority claim(s) or which is cited to establish the publication date of another citation or other special reason (as specified)
- *O* document referring to an oral disclosure, use, exhibition or other means
- *P* document published prior to the international filing date but later than the priority date claimed

- *T* later document published after the international filing date or priority date and not in conflict with the application but cited to understand the principle or theory underlying the invention
- *X* document of particular relevance; the claimed invention cannot be considered novel or cannot be considered to involve an inventive step when the document is taken alone
- *Y* document of particular relevance; the claimed invention cannot be considered to involve an inventive step when the document is combined with one or more other such documents, such combination being obvious to a person skilled in the art.
- * & * document member of the same patent family

Date of the actual completion of the international search

22 July 2004

Date of mailing of the international search report

29/07/2004

Name and mailing address of the ISA

 European Patent Office, P.B. 5818 Patentlaan 2
 NL - 2280 HV Rijswijk
 Tel. (+31-70) 340-2040, Tx. 31 651 epo nl,
 Fax: (+31-70) 340-3016

Authorized officer

Mootz, F

INTERNATIONAL SEARCH REPORT

national Application No
PCT/DK2004/000257

| C.(Continuation) DOCUMENTS CONSIDERED TO BE RELEVANT | | |
|--|--|-----------------------|
| Category ° | Citation of document, with indication, where appropriate, of the relevant passages | Relevant to claim No. |
| X | FR 2 679 019 A (CHEN DE SHEN) 15 January 1993 (1993-01-15) | 1-3,7,9, 10,13,14 |
| Y | page 3, column 3, line 18 - line 29; figures 2-6 | 11 |
| Y | ----- US 6 147 295 A (MORI MASAHIRO ET AL) 14 November 2000 (2000-11-14) column 5, line 36 - line 62; figures | 11 |
| X | ----- US 3 875 925 A (JOHNSTON JOHN G) 8 April 1975 (1975-04-08) column 4, line 12 - line 41 column 6, line 4 - line 32; figures 4,5 | 1-3,7 |

INTERNATIONAL SEARCH REPORT

Information on patent family members

national Application No

PCT/DK2004/000257

| Patent document cited in search report | A | Publication date | Patent family member(s) | Publication date |
|--|---|------------------|---|--|
| DE 19824027 | A | 02-12-1999 | DE 19824027 A1 | 02-12-1999 |
| US 4309983 | A | 12-01-1982 | NONE | |
| US 4282860 | A | 11-08-1981 | JP 1063789 C JP 53078431 A JP 56004816 B | 22-09-1981 11-07-1978 02-02-1981 |
| US 4400577 | A | 23-08-1983 | AU 8767882 A EP 0084051 A1 MX 154282 A WO 8300409 A1 | 17-03-1983 27-07-1983 29-06-1987 03-02-1983 |
| FR 2679019 | A | 15-01-1993 | FR 2679019 A1 | 15-01-1993 |
| US 6147295 | A | 14-11-2000 | JP 3315575 B2 JP 9213984 A CN 1163382 A ,B EP 0789404 A1 | 19-08-2002 15-08-1997 29-10-1997 13-08-1997 |
| US 3875925 | A | 08-04-1975 | JP 975928 C JP 50101941 A JP 54010137 B | 30-10-1979 12-08-1975 01-05-1979 |