

[54] **DEVICE FOR THE PROTECTION OF TARGETS AGAINST PROJECTILES**

[75] Inventor: Nathaniel B. Wales, Jr., Morristown, N.J.

[73] Assignee: The United States of America as represented by the Secretary of the Army, Washington, D.C.

[22] Filed: Dec. 1, 1954

[21] Appl. No.: 472,541

[52] U.S. Cl. 89/36 R; 89/36 H; 102/19.2; 102/24 HC; 102/70.2 R

[51] Int. Cl. F41h 9/00

[58] Field of Search 89/1, 1 A, 36 T, 36.1, 89/36.5, 1 R, 36 R, 36 H, 36 F, 36 G, 36 Z; 102/16 T, 14.6, 18, 24 HC

[56] **References Cited**

UNITED STATES PATENTS

914,371	3/1909	Davis.....	102/16 T
1,195,042	8/1916	Leon.....	89/1 A
2,409,848	10/1946	Greulich.....	102/22

2,513,279	7/1950	Bradley.....	89/1 A
2,543,057	2/1951	Porter.....	102/24
2,668,512	2/1954	Klas.....	89/1 A X

Primary Examiner—Stephen Bently
 Attorney, Agent, or Firm—Robert P. Gibson; Nathan Edelberg

EXEMPLARY CLAIM

1. In a device for protecting a target from attack by a projectile the combination comprising a linear shaped charge to generate a jet sheet of high velocity particles, the plane of symmetry of said shaped charge disposed in spaced relation to said target and substantially at right angles to the projectile trajectory, a detonator to initiate explosion of said shaped charge, a source of electrical energy to fire said detonator, and a switch responsive upon impact of said projectile to establish connection between said source of electrical energy and said detonator said switch comprising a plurality of plates disposed in parallel planes and distortable by said projectile impact.

5 Claims, 5 Drawing Figures

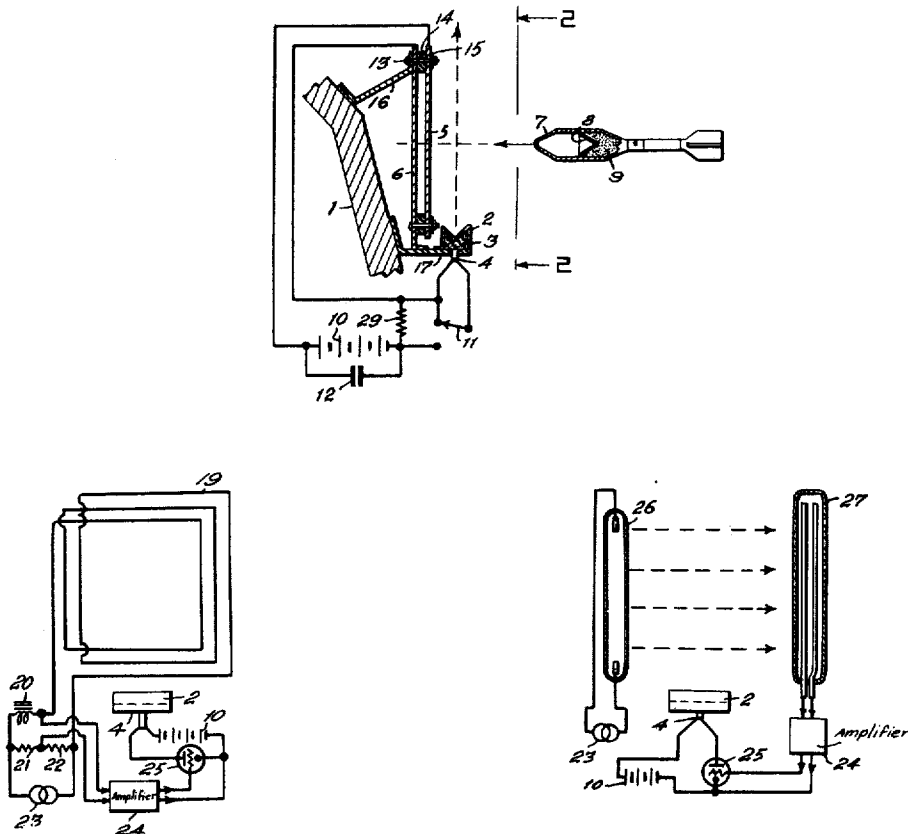

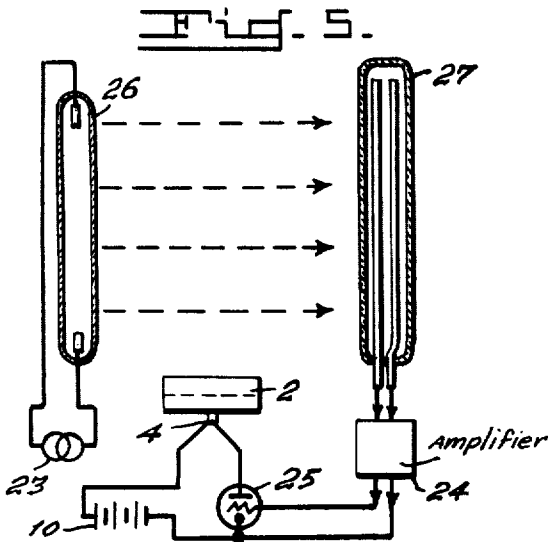
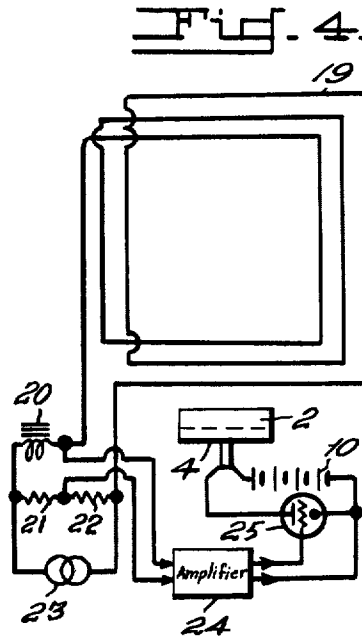
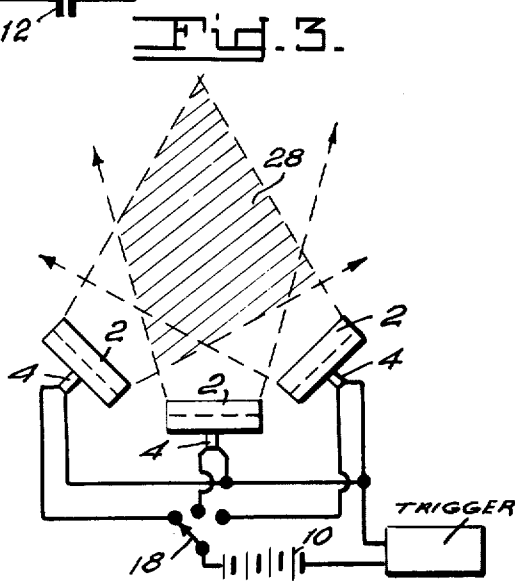
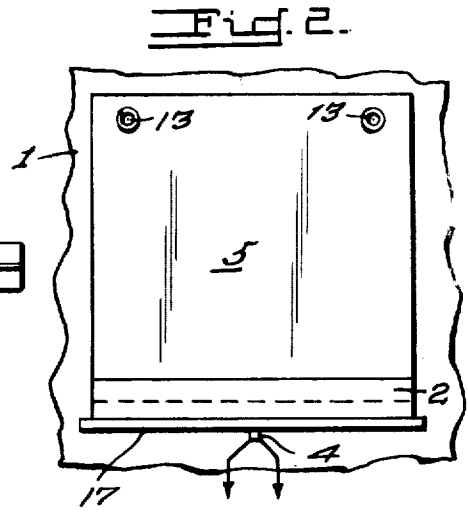
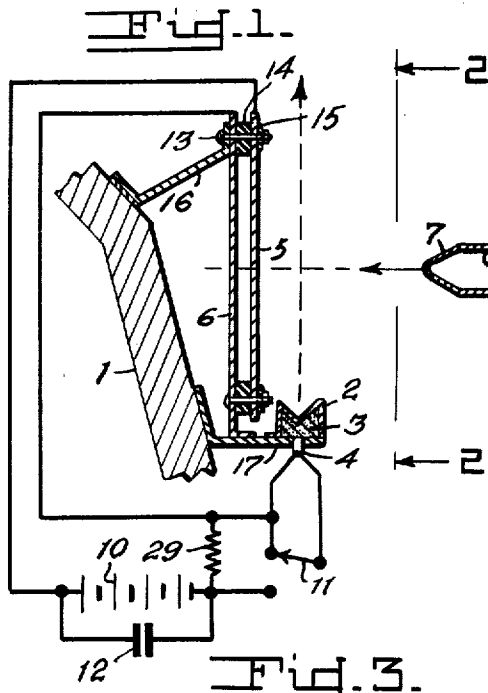

INVENTOR.
 Nathaniel B. Wales, Jr.
 BY
N. E. Thibodeau, A. W. Dew
and A. P. Smith ATTORNEYS.

DEVICE FOR THE PROTECTION OF TARGETS AGAINST PROJECTILES

This invention may be manufactured and used by or for the Government for governmental purposes without the payment to me of any royalty thereon.

The invention relates generally to a method and apparatus for protecting a target against attack. For example the common infantry antitank weapon is the "bazooka" or rocket propelled shaped charge which because of its relatively low velocity of attack requires a precisely symmetrical conical liner in the shaped charge in order to properly penetrate the armor of the tank. The invention disclosed herein, briefly, comprises generating a jet sheet of high velocity particles and shock waves by means of a linear shaped charge, the jet being directed in a plane intersecting the trajectory of the attacking projectile substantially at right angles thereto, the jet sheet being generated at an instant when the forward portion of the projectile lies in the jet plane.

It is accordingly a broad object of my invention to provide a target defensive system.

It is further object of my invention to provide a method of target defense by providing a generator of a jet sheet of high velocity particles to intersect the path of the projectile.

It is a still further object of my invention to provide a system of target defense wherein approach of an attacking projectile triggers a defending charge to turn aside the projectile.

It is a yet still further object of my invention to provide a system of target defense wherein an attacking projectile triggers a linear shaped charge disposed to discharge shock waves and a jet of high velocity particles in a plane normal to the projectile trajectory to distort or deflect the same.

With these and other objects in mind, which will in part be obvious, reference is made to the drawings in which:

FIG. 1 is a longitudinal section of my invention through the tank armor illustrating the triggering screen.

FIG. 2 is an elevation of the trigger screen taken on lines 2—2 of FIG. 1.

FIG. 3 is a modification of the depending charge of FIG. 1.

FIG. 4 is a modification of the triggering structure.

FIG. 5 is a further modification of the triggering structure.

Referring now to FIG. 1 of the drawings wherein similar parts are designated by similar reference characters, 1 indicates a portion of the armor of a tank or other target to the exterior of which is attached screen members 5 and 6 by means of brackets 16 and 17. The linear shaped charge consists of a metal V-shaped trough member 2 loaded with high explosive 3. The defending linear charge 2 is secured to bracket 17, and is provided with an electric detonator 4 for initiating the high explosive 3. The plane of the sheet jet formed by liner 2 is thus positioned parallel to the plane of the trigger screen 5-6. The trigger screen consists of the metal backing plate 6 to which is secured the front metal contact plate 5 by the insulating and spacing washers 14 and 15 and by the rivets 13. Plates 5 and 6, which are thus insulated one from another, are utilized as a switch adapted to be closed by the impact of a pro-

jectile. A representative attacking rocket-projected shaped charge 7 is shown in FIG. 1 approaching the target 1. The relative anticipated position of the cone 8 and charge 9 to the nose of the attacking round 7 will determine the choice of the position of charge 2 relative to screen 5 so as to cause the jet sheet of 2 to intersect cone 8 at the instant of impact between round 7 and screen 6.

Arming switch 11 is a single pole double throw switch shown in the "safe" position in which the electric detonator 4 is short circuited. On moving switch 11 to the opposite position to that shown, detonator 4 is connected in series with battery 10 and screen switch 5-6 so that closure of the latter will detonate the line charge. The capacitor 12, connected across battery 10, serves as a high current storage source to guarantee fast detonation of detonator 4. The purpose of the high resistance resistor 29 is to precharge the distributed capacitance of screen 5-6 so that the actuating of switch 11 from the safe to the armed position will not prematurely detonate detonator 4 by the charging current to screen 5-6.

In operation, the device of FIGS. 1 and 2, with switch 11 in the armed position, responds to the impact of projectile 7 on screen 5-6 by projecting a sheet of fragments of the linear shaped charge 2 upward parallel to the plane of screen 5 at a velocity of the order of 25,000 feet per second. The total time between contact of the attacking projectile with screen 6 and the arrival of the counter-attacking jet sheet at the attacking round may be made to be 50 microseconds or less. This jet sheet perforates and distorts cone 8 and generally, in addition, initiates charge 9 at its lower side. This flank counter-attack results in the defeat of the attacking round by making it incapable of penetrating the armor plate 1.

In FIG. 3, an array of three line shaped charges such as shown at 2, 3, and 4 of FIG. 1 is arranged so that the jet sheet of each overlaps a commonly defended area 28 without intersecting the remaining line charges. Sequence switch 18 is then arranged so as to cause the trigger screen switch to detonate a new defending line charge for each new attack. If necessary, short barriers (not shown) between each linear charge may be used to prevent sympathetic detonation of the adjacent linear charges.

FIG. 4 illustrates an alternative form of trigger screen employing the disturbance in an alternating magnetic field created by the presence of the attacking round to initiate the counter-attacking linear charge. This disturbance may either take the form of a change in inductance of the coil 19 producing the alternating magnetic field, due to the ferromagnetic character of the attacking round, or the form of a lowering of the Q of this coil due to the conductive character of the attacking round with the resulting eddy currents induced therein by the oscillatory field. Coil 19 is connected in a normally balanced Wheatstone bridge including inductance 20 and resistors 21 and 22. The alternating current source 23 excites this bridge, and is responsible for the field generated by the trigger screen coil 19. The output of the bridge is connected to the amplifier 24, whose time constants may be adjusted to respond only to changes having a predetermined minimum rate of change so as to discriminate against slow moving objects which might otherwise give false indications. Unbalance of the bridge results in a signal being impressed on the

grid of the gaseous cold cathode discharge tube 25 thereby discharging battery 10 through detonator 4 and initiating linear charge 2.

A third alternative trigger screen system using visible or infrared light is shown in FIG. 5. In this case a current source 23 is connected to excite a light source 26. This light is allowed to fall on the photoelectrically sensitive device 27. Amplifier 24 is designed to respond to a rate of change of the light received by cell 27, so that on the entry of the attacking round into the light screen 10 emitted by source 26, a voltage pulse will be imposed on the grid of cold cathode discharge tube 25, thereby initiating defending charge 2, via detonator 4 and battery 10, as before.

The application of the method of my invention to an attacking shaped charge results first in the destruction of the symmetry, and consequently the penetrating power of the cone and explosive system of the attacking shaped charge, and by perforating, cutting and distorting this cone. Secondly, such a flank counter-attack generally results in the high-order initiating of the high explosive content of the attacking round at a point lying on one side of its cone instead of at its apex, thereby frequently preventing the formation of a jet by the attacking round.

In the case of an attack by a kinetic armor-piercing type of projectile, the application of this method results first in the transfer of a substantial amount of momentum to the attacking round from the jet sheet at a point forward of its center of gravity thus producing a rotational couple tending to precess the spinning projectile so that its axis is turned from parallelism with the line of the trajectory, and the shell will tend to strike partially broadside due to this large induced yaw. A second factor of this invention which degrades the penetrating ability of kinetic rounds is the ability of the counter-attacking jet sheet to produce shock waves which fracture the hardened core of such projectiles, and thereby diminish their ability to penetrate armor.

In the application of this defense system to a tank it is desirable that the area of the tank to be protected be divided into a plurality of composite areas each having its independent trigger screen. In addition, it is desirable in this application that a given area be capable of defeating repeated attacks. The FIG. 3 species illustrates this structure.

My novel defensive system provides the following advantages:

1. Low weight per area protected.
2. Effectiveness against both shaped charge and kinetic projectiles.
3. Ease of replacement.
4. Low interference with vision.

What I claim is:

1. In a device for protecting a target from attack by a projectile the combination comprising a linear shaped charge to generate a jet sheet of high velocity particles, the plane of symmetry of said shaped charge disposed in spaced relation to said target and substantially at right angles to the projectile trajectory, a detonator to initiate explosion of said shaped charge, a source of electrical energy to fire said detonator, and a switch responsive upon impact of said projectile to establish connection between said source of electrical energy and said detonator said switch comprising a plurality of

plates disposed in parallel planes and distortable by said projectile impact.

2. In a device for protecting a target from attack by a projectile the combination comprising a plurality of linear shaped charges to generate a jet sheet of high velocity particles, the plane of symmetry of one said shaped charge disposed in spaced relation to said target and substantially at right angles to the projectile trajectory, the other said shaped charges having their respective longitudinal axes of symmetry disposed in said plane and forming obtuse angles with the axis of said one shaped charge, a detonator to explode each said shaped charge, a source of electrical energy to fire said detonators, and a sequence switch responsive to successive projectile arrivals to connect said source of electrical energy to successive detonators.

3. In a device for protecting a target from attack by a projectile the combination comprising a linear shaped charge to generate a jet sheet of high velocity particles, the plane of symmetry of said shaped charge disposed in spaced relation to said target and substantially at right angles to the projectile trajectory, a detonator to initiate explosion of said shaped charge, a source of electrical energy to fire said detonator and means responsive to presence of the projectile to connect said source of electrical energy to said detonator, said means comprising a trigger screen, a source of alternating energy to energize said screen, said screen forming one arm of a normally balanced Wheatstone bridge, a vacuum tube connect to said bridge and responsive to bridge unbalance to connect said source of electrical energy to said detonator, said projectile acting to vary the inductance of said trigger screen to unbalance said bridge.

4. In a device for protecting a target from attack by a projectile the combination comprising a linear shaped charge to generate a jet sheet of high velocity particles, the plane of symmetry of said shaped charge disposed in spaced relation to said target and substantially at right angles to the projectile trajectory, a detonator to initiate explosion of said shaped charge, a source of electrical energy to fire said detonator, and means responsive to presence of the projectile to connect said source of electrical energy to said detonator, said means comprising a photoelectrically sensitive screen, a source of light directed toward said screen and a vacuum tube normally cut off and responsive to partial interruption of light by the projectile to connect said source of electrical energy with said detonator.

5. In a device for the defence of a target from an attacking projectile, a trigger screen comprising a pair of spaced parallel, insulated plates mounted at the side of said target, a linear shaped charge having its length substantially equal to the length of said screen, said charge adapted to generate a jet sheet of high velocity particles, its plane of symmetry being disposed in spaced relation to said target and substantially at right angles to the trajectory of said attacking projectile, a detonator, a source of electrical energy, and an arming switch adapted to establish electrical connection between said screen, said electrical energy source and said detonator to arm said device for exploding said shaped charge upon collision with said screen by said attacking projectile.

* * * * *