



(19) **United States**
(12) **Patent Application Publication**
Cohagan et al.

(10) **Pub. No.: US 2012/0197707 A1**
(43) **Pub. Date: Aug. 2, 2012**

(54) **LOYALTY POINTS SYSTEM AND METHOD WITH SUPPLEMENTAL AUTHORIZATIONS**

(75) Inventors: **Perry A. Cohagan**, Brooklyn Heights, NY (US); **Birgitta Mayer**, New York, NY (US); **Julia Menichilli**, Manhasset, NY (US); **Theodore S. Voltmer**, Caldwell, NJ (US); **Penelope Wood-Kulko**, Brooklyn, NY (US)

(73) Assignee: **Propulsion Remote Holdings, LLC**, Dover, DE (US)

(21) Appl. No.: **13/444,171**

(22) Filed: **Apr. 11, 2012**

Related U.S. Application Data

(63) Continuation of application No. 10/708,568, filed on Mar. 11, 2004, now Pat. No. 8,180,671, which is a continuation-in-part of application No. 10/378,456, filed on Mar. 3, 2003, now Pat. No. 7,467,096, which is a continuation-in-part of application No. 10/027,984, filed on Dec. 21, 2001, now Pat. No. 7,613,628, which is a continuation-in-part of application No. 09/836,213, filed on Apr. 17, 2001, now Pat. No. 7,398,225, said application No. 10/708,568 is a continuation-in-

part of application No. 10/304,251, filed on Nov. 26, 2002, now Pat. No. 7,613,629, which is a continuation-in-part of application No. 09/836,213, filed on Apr. 17, 2001, now Pat. No. 7,398,225.

(60) Provisional application No. 60/482,644, filed on Jun. 26, 2003, provisional application No. 60/279,817, filed on Mar. 29, 2001.

Publication Classification

(51) **Int. Cl.**
G06Q 30/02 (2012.01)
(52) **U.S. Cl.** **705/14.27**

(57) **ABSTRACT**

The invention facilitates pooling, gifting or transferring of geographic area loyalty points between accounts. The invention also facilitates a transfer of geographic area loyalty points from a consumer account associated with a sponsoring company to a consumer account associated with a host company. The invention may also facilitate gifting of loyalty points to charitable organizations on a recurring basis, wherein the gifting may transfer any portion of geographic based points to various charities. The system may also convert the geographic area loyalty points to a monetary value, thereby allowing the points to be donated to a charity such that the donation appears to be a monetary value donation to the charity.

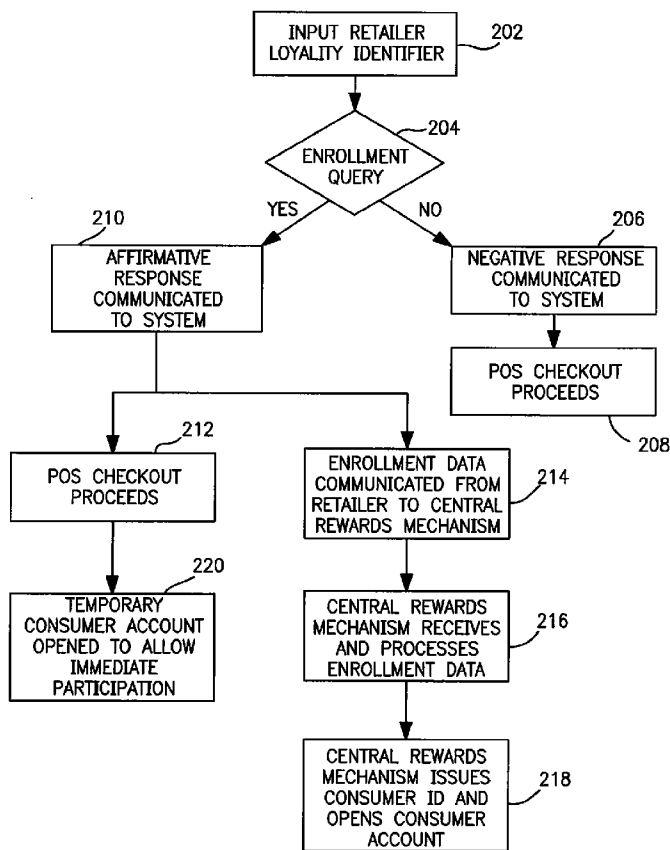

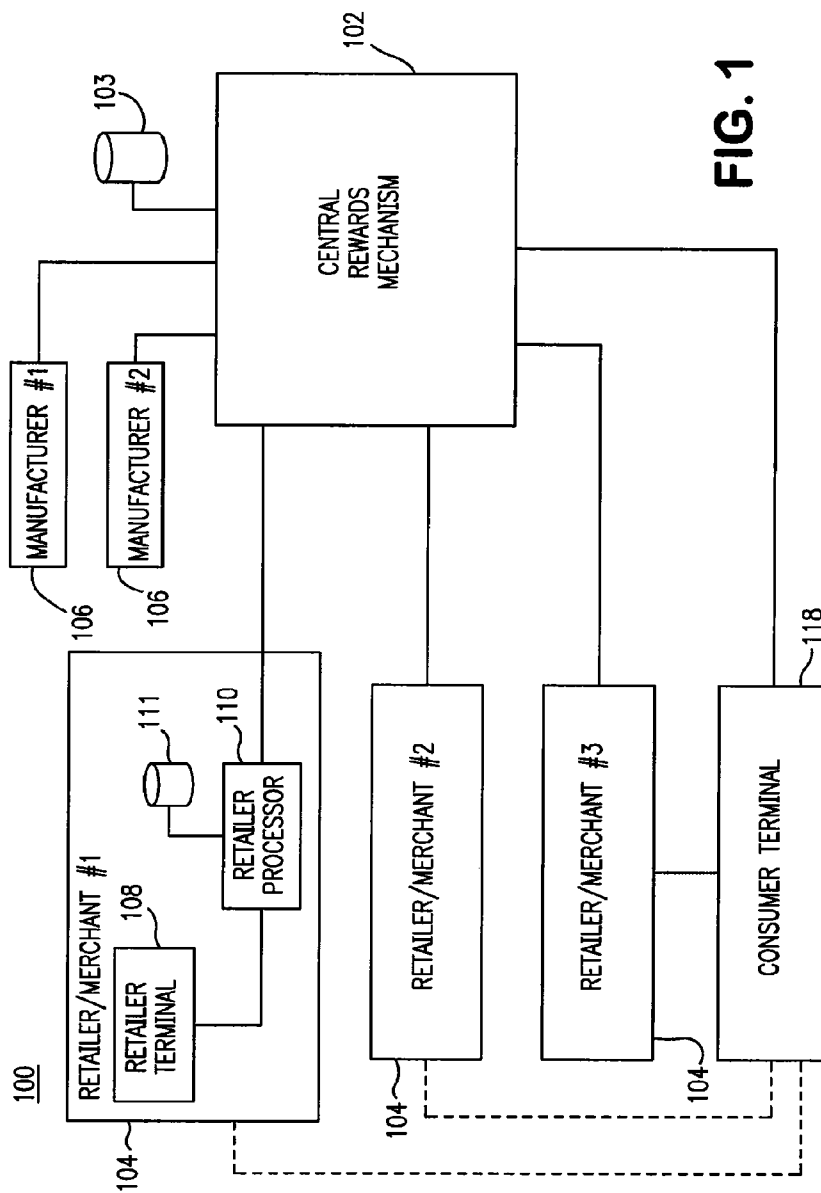

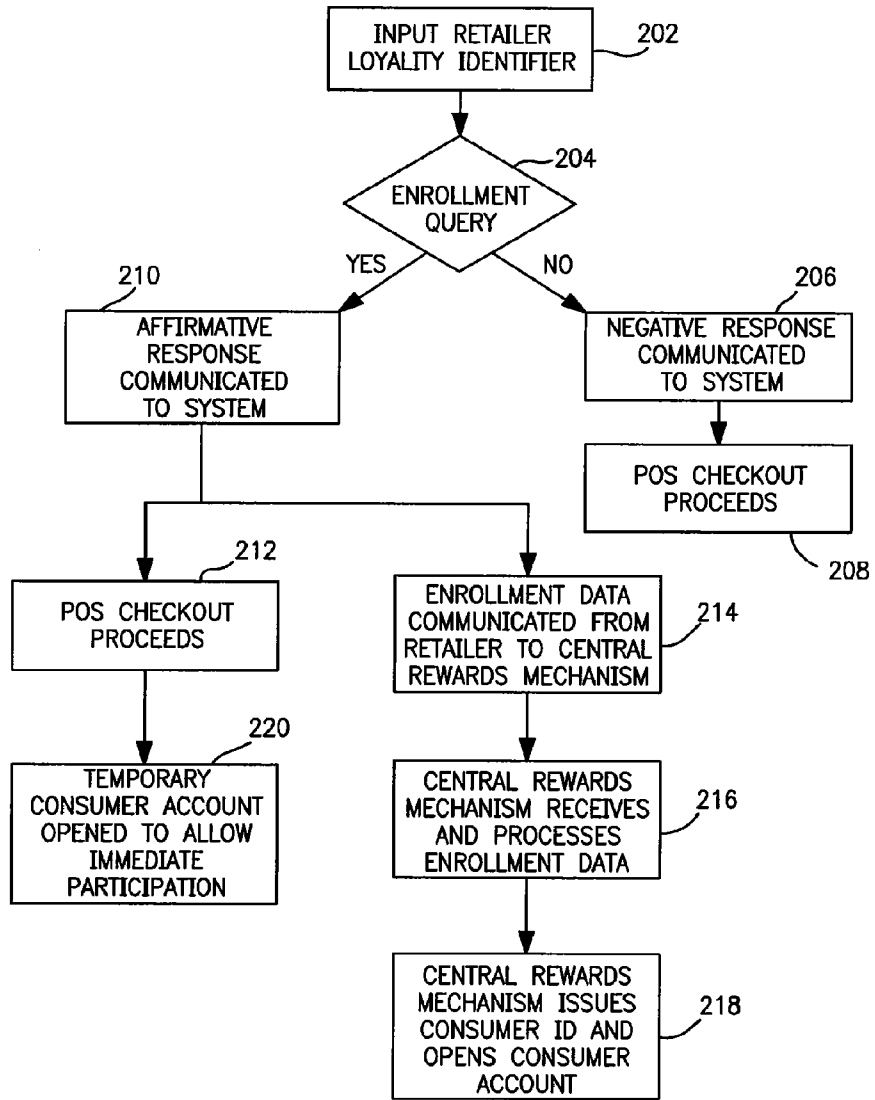

FIG. 2

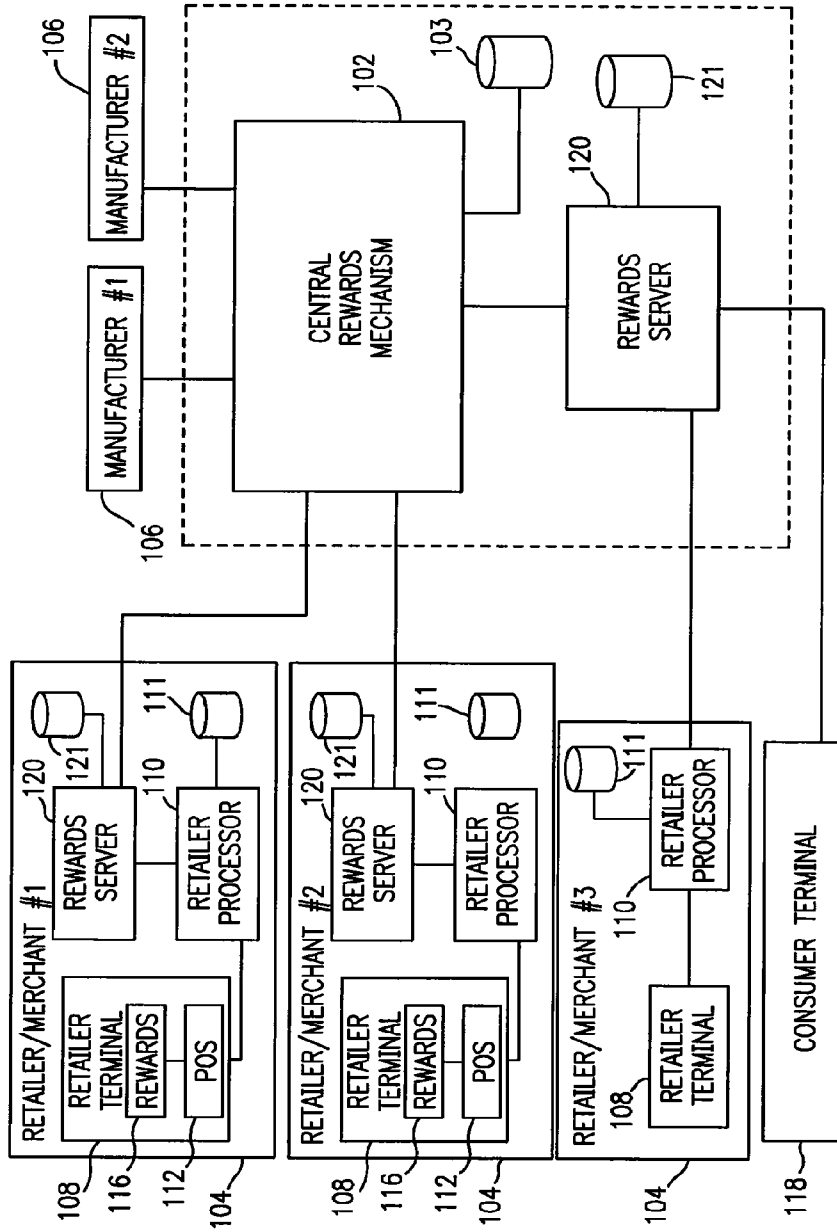

FIG. 3

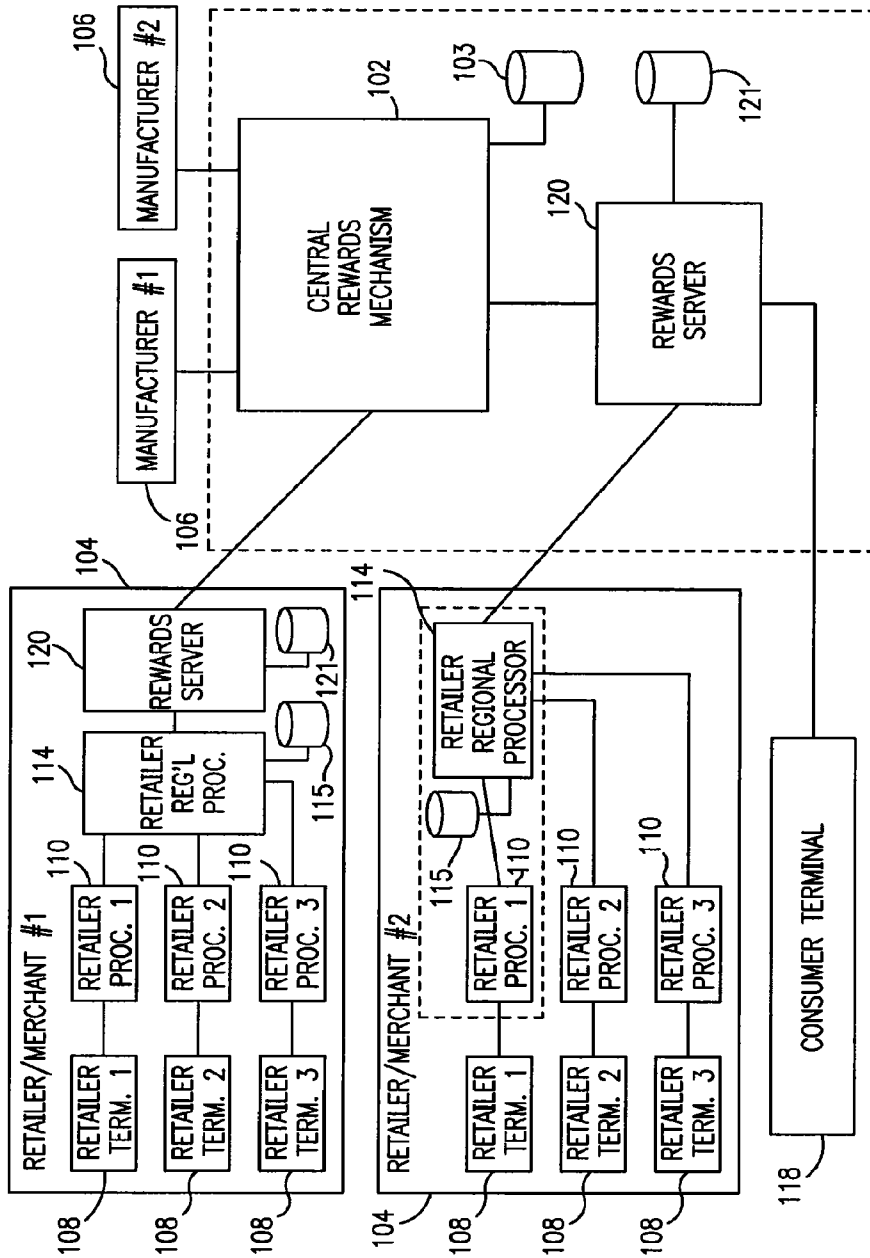

FIG. 4

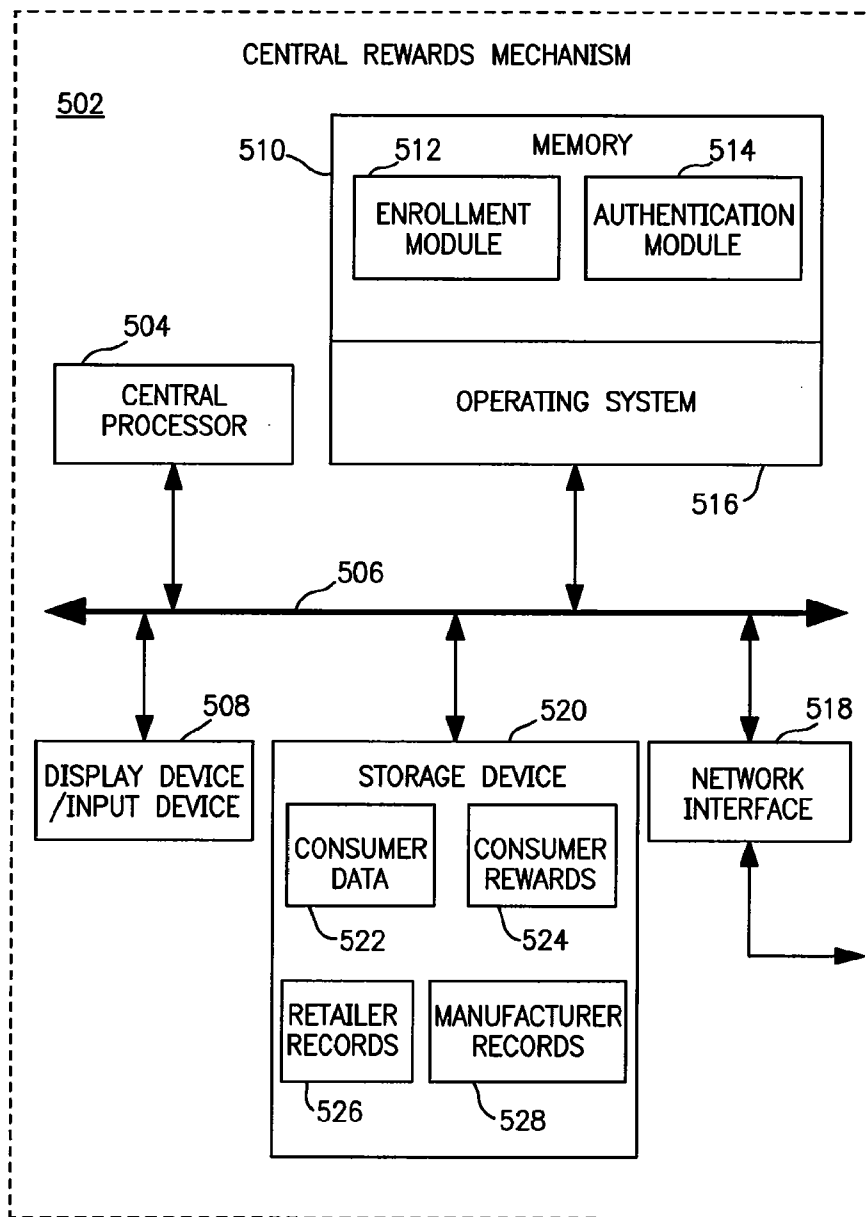

FIG. 5

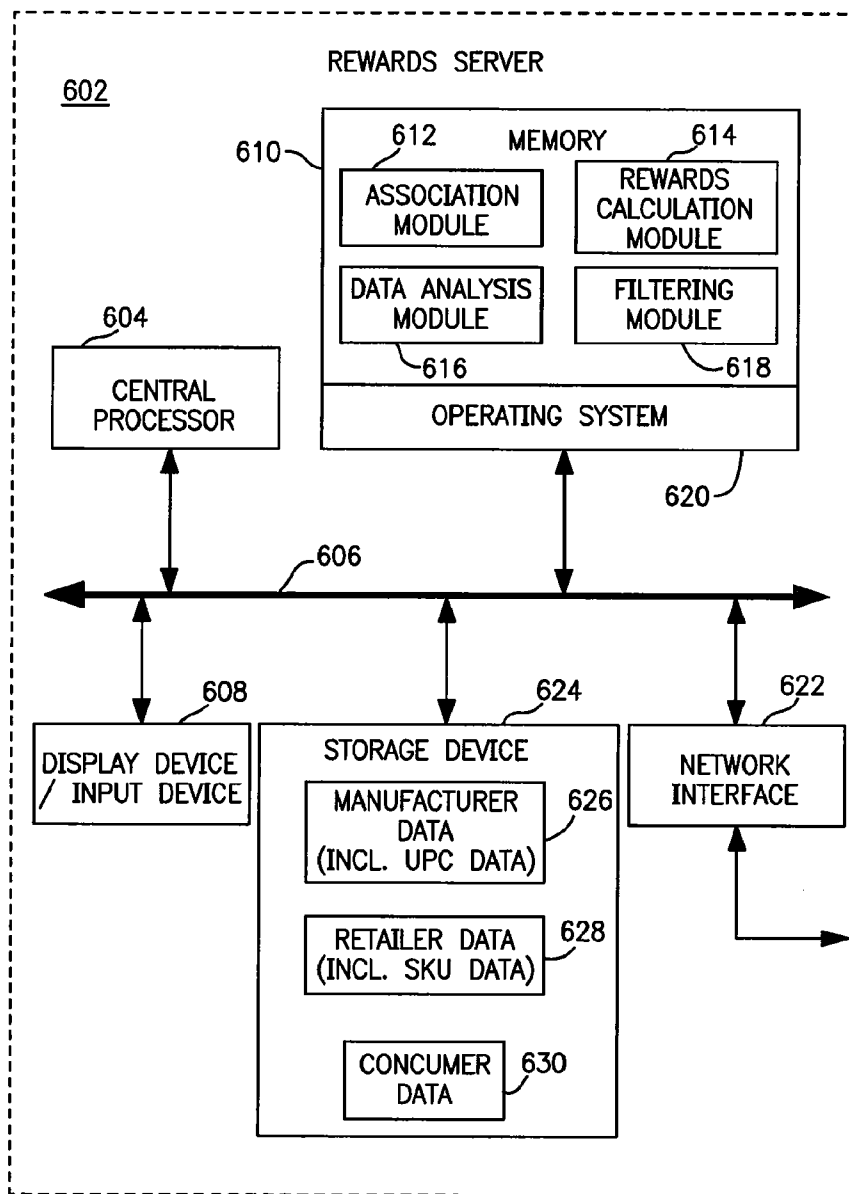

FIG. 6

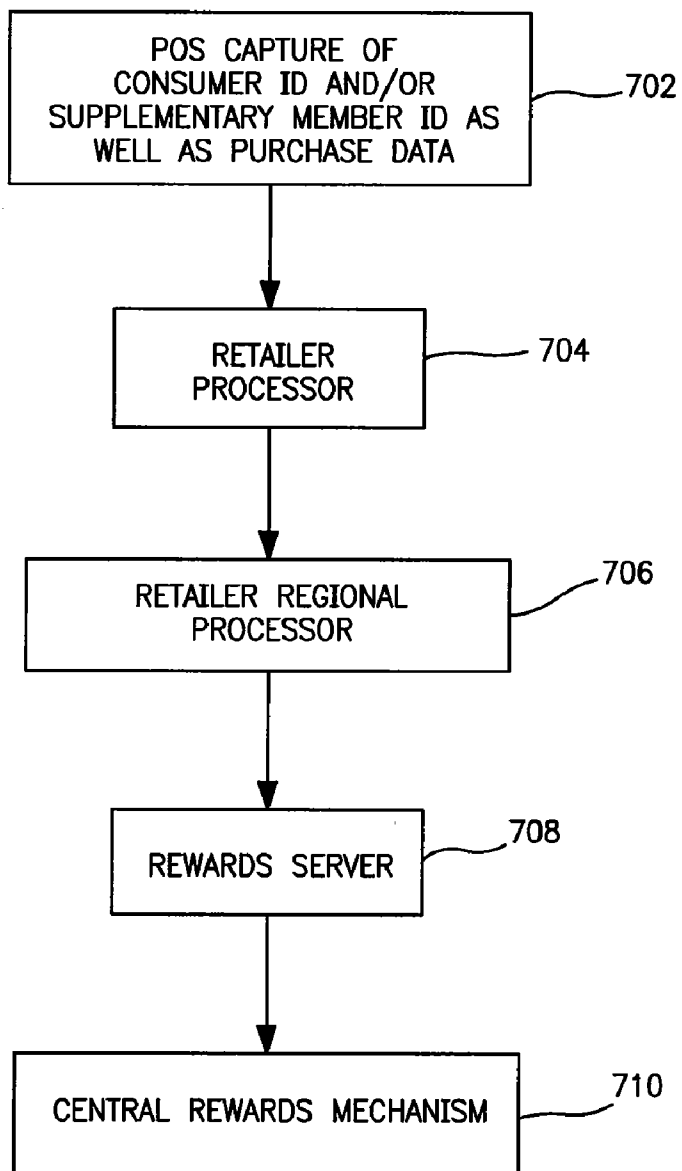

FIG. 7

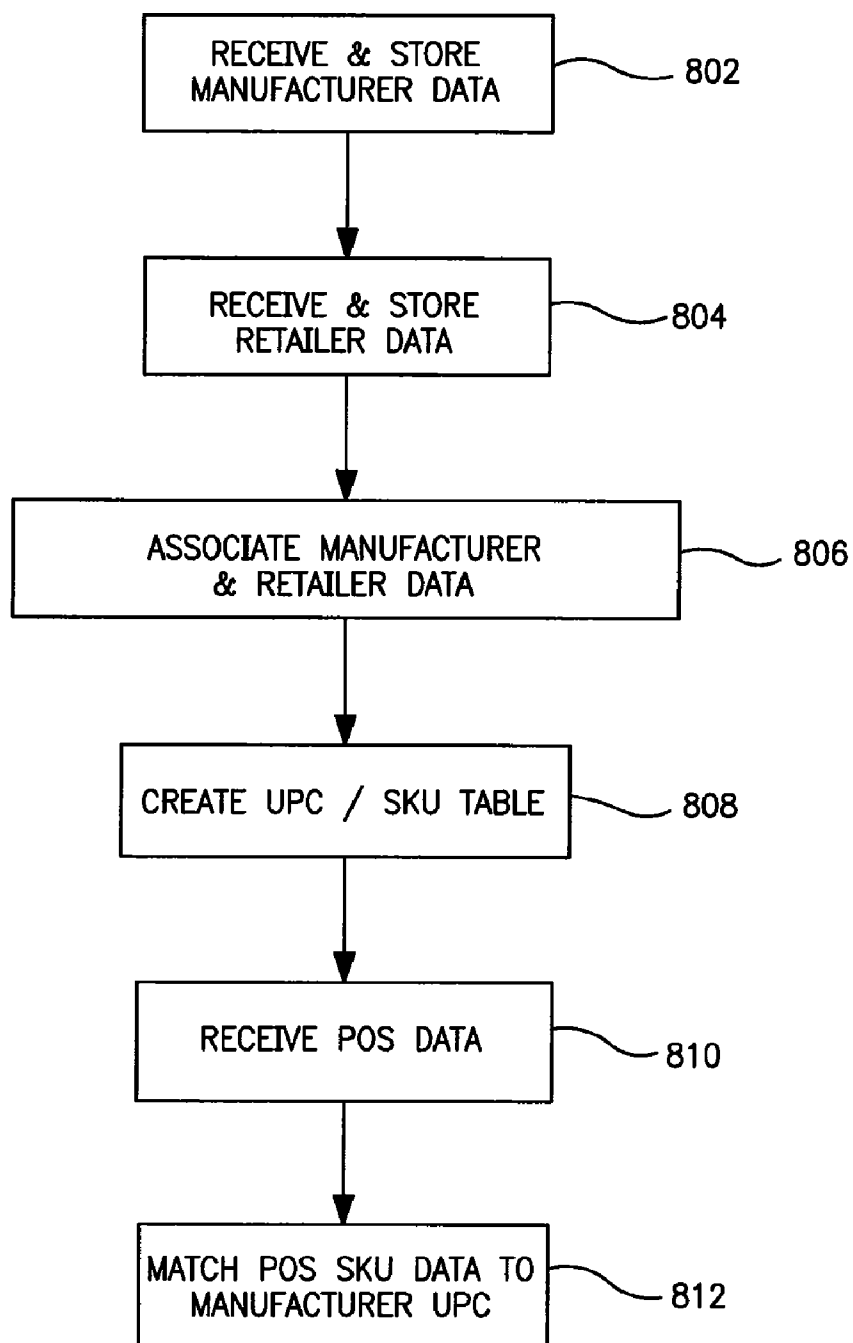

FIG. 8

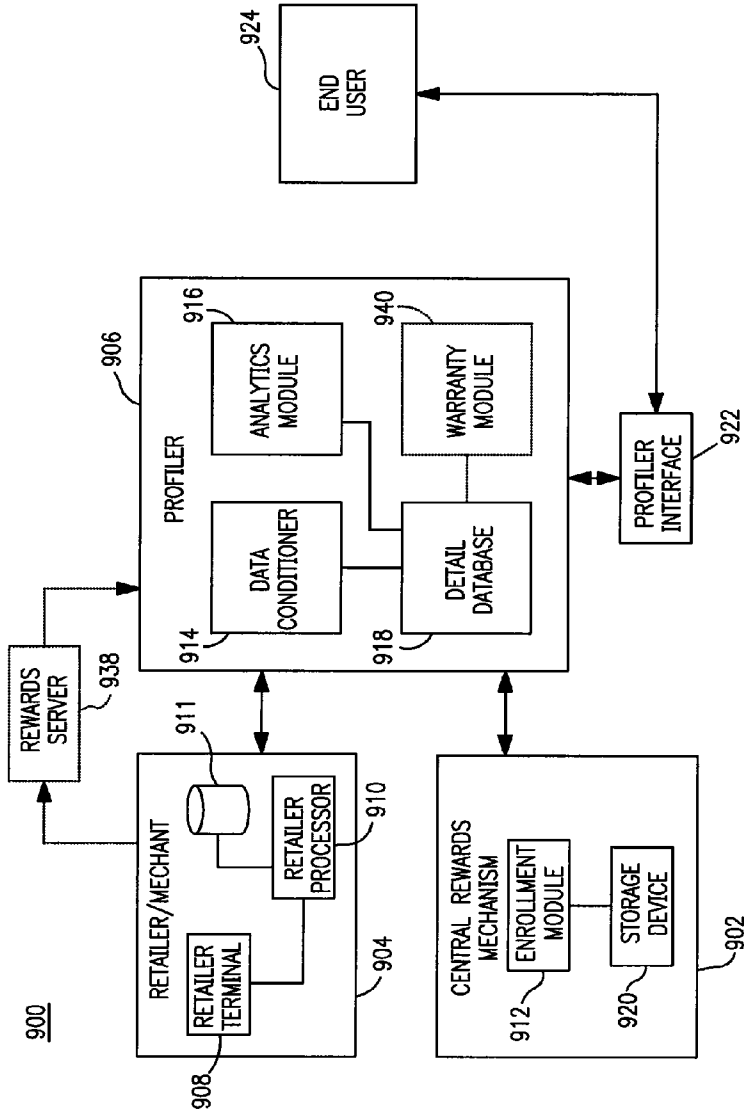

FIG. 9



FIG. 10

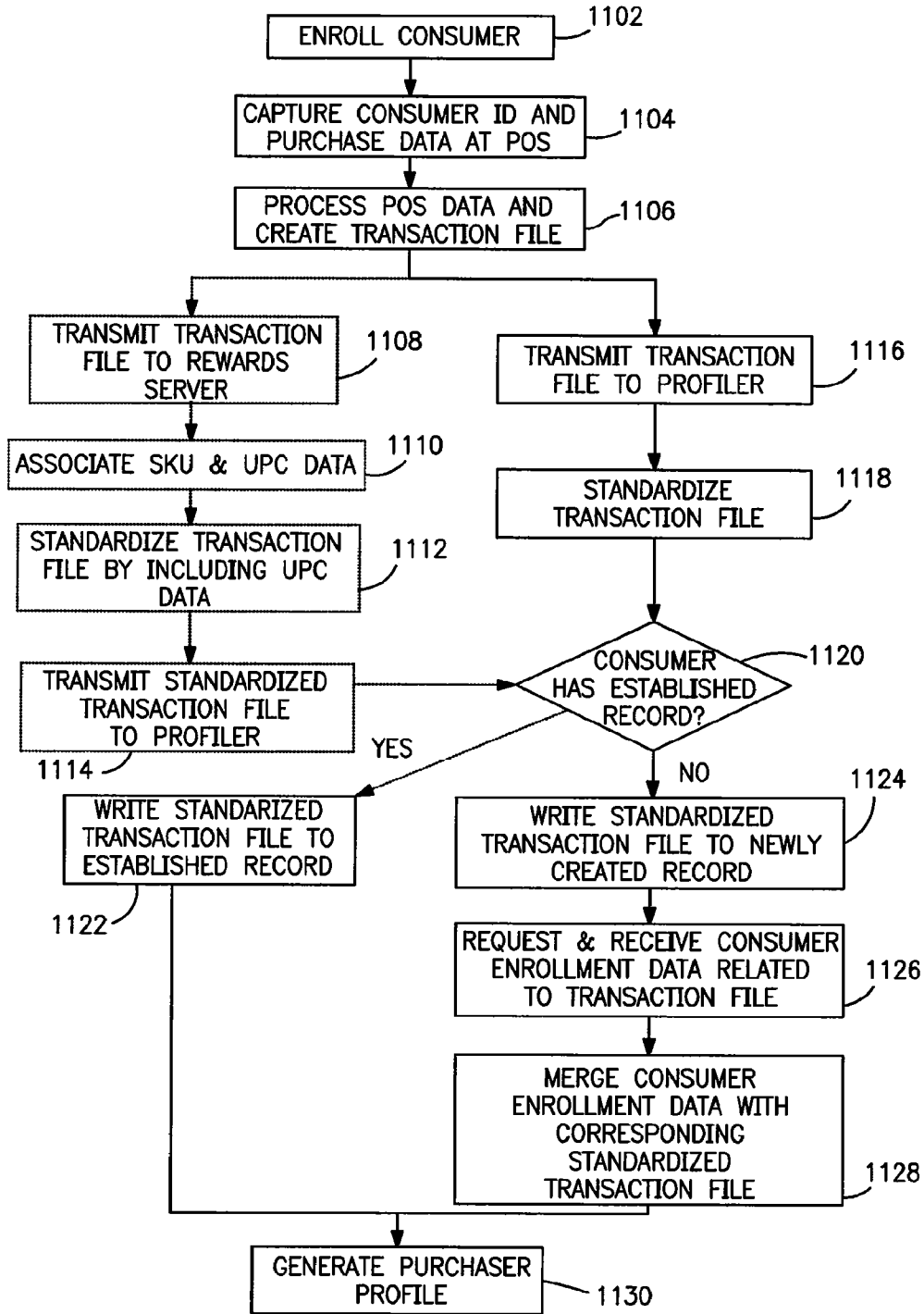

FIG. 11

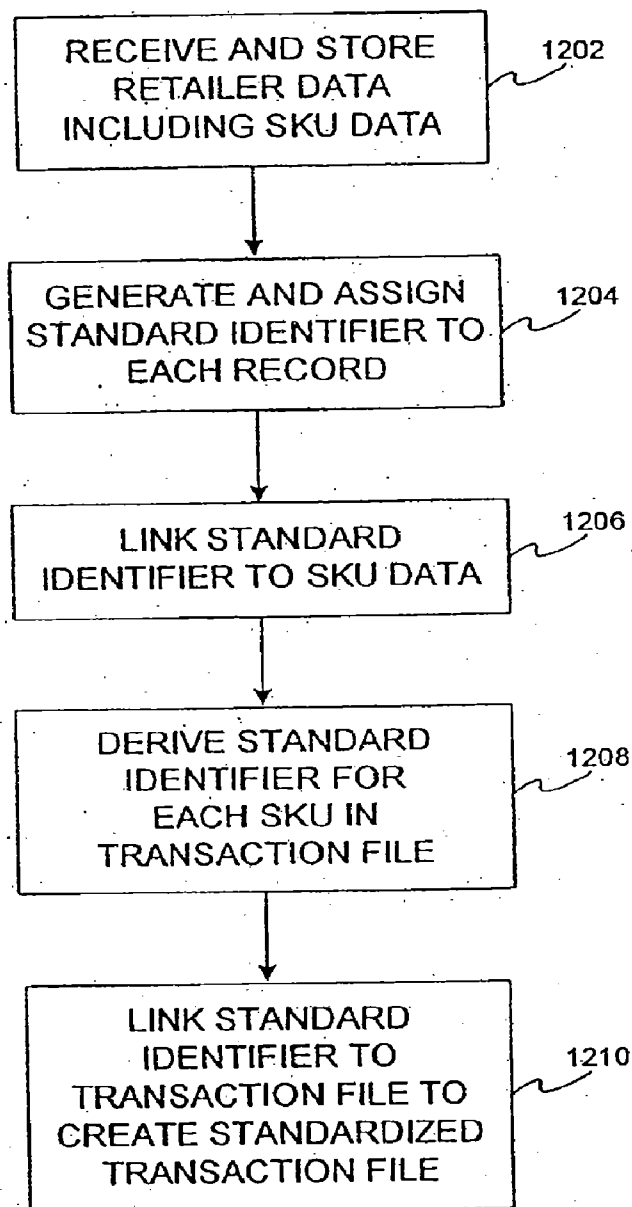

FIG. 12

LOYALTY POINTS SYSTEM AND METHOD WITH SUPPLEMENTAL AUTHORIZATIONS

CROSS REFERENCE TO RELATED APPLICATIONS

[0001] This application claims priority to, and is a continuation-in-part of, U.S. Ser. No. 10/378,456, filed Mar. 3, 2003 and entitled "System and Method for Real-Time Transfer of Loyalty Points Between Accounts." The '456 application claims priority to, and is a continuation-in-part of, U.S. Ser. No. 10/027,984, filed Dec. 21, 2001 and entitled "System And Method For Networked Loyalty Program." This application also claims priority to, and is a continuation-in-part of, U.S. Ser. No. 10/304,251 filed on Nov. 26, 2002 and entitled "SYSTEM AND METHOD FOR TRANSFER OF LOYALTY POINTS." The '984 application and the '251 application claim priority to, and are continuations-in-part of, U.S. Ser. No. 09/836,213, filed Apr. 17, 2001 and entitled "System and Method for Networked Loyalty Program", which itself claims priority to, and the benefit of, U.S. Provisional Application Ser. No. 60/279,817, filed Mar. 29, 2001 and entitled "System and Method for Networked Incentive Awards Program". This application also claims benefit from, and priority to, U.S. Provisional Patent Application Ser. No. 60/482,644, filed Jun. 26, 2003, which is all hereby incorporated by reference. This application hereby incorporates by reference all of these prior applications in their entireties.

FIELD OF INVENTION

[0002] The present invention generally relates to loyalty systems, and more particularly, to a system and method for transferring, pooling and gifting geographic area loyalty points.

BACKGROUND OF INVENTION

[0003] Loyalty programs have been relatively successful; however, numerous loyalty programs exist, so businesses have a difficult time differentiating their loyalty programs from other loyalty programs on the market. Moreover, many consumers often travel for work related reasons, so they may not desire to use their loyalty points to travel to distant cities or distant countries. Rather, many consumers enjoy the benefits of their "hometown" region, including local restaurants, local theaters, local sporting activities and other events. At the same time, marketers have begun to understand that many consumers develop a strong pride, emotional affinity and loyalty to the geographic region where they live. As such, a long-felt need exists for a loyalty program which rewards consumers for purchases in certain local geographic areas and which enables consumers to utilize their loyalty points in a similar local geographic area.

[0004] Loyalty point systems also typically include individual consumer loyalty point accounts which record the balance of loyalty points earned by the individual consumer, wherein the loyalty points may be earned within a particular geographic area. The consumer may be part of a family or organization and the consumer may desire to share or transfer the consumer's loyalty points in a geographic area to other members of the consumer's family or organization. Moreover, a consumer may immediately need additional loyalty points in a geographic area in his or her own loyalty account in order to have a sufficient number of loyalty points for a certain award. The consumer may also know of a friend or

relative who has excess loyalty points in a geographic area that they would gladly transfer to the consumer in need of additional loyalty points. However, because many loyalty point accounts are associated with a single consumer, existing loyalty systems do not allow a consumer to efficiently transfer loyalty points to another consumer loyalty point account. Moreover, while some loyalty accounts may allow the consumer to use the loyalty points in a geographic area to purchase gifts for others, the loyalty points are not sufficiently transferable to another consumer such that the other consumer can purchase the same gift or aggregate points for a different gift.

[0005] Moreover, to promote loyalty to a particular company, many of the above-described loyalty programs are sponsored by and operated by a company such that the consumers are typically required to earn and burn the loyalty points through the same company. As such, a particular sponsoring company may market its own loyalty points under a particular trademark (e.g., Membership Rewards sponsored by American Express, DeltaMiles sponsored by Delta Airlines, Hilton Rewards sponsored by Hilton Hotels, ePloids sponsored by Frito-Lay and FlightFund sponsored by America West Airlines) and maintain loyalty point accounts for each consumer, wherein the accounts include only loyalty points associated with the sponsoring company. Accordingly, the consumers in the sponsoring company loyalty program typically earn loyalty points from the sponsoring company, then the consumers spend the sponsored loyalty points on reward items offered by the sponsoring company.

[0006] However, it is often difficult for an individual sponsoring company to offer a sufficiently wide range of reward items in certain geographic areas to satisfy the varied interests of its consumers. Moreover, many of the consumers may only engage in a limited amount of business in a certain geographic area with the particular sponsoring company and/or may only earn a limited amount of sponsored loyalty points from the sponsoring company within the geographic area. As such, a consumer's loyalty point account with the sponsoring company may include a minimal amount of loyalty points in a geographic area and the minimal point balance may be insufficient to obtain any desired reward item in the geographic area. Additionally, even if a consumer obtains a sufficient point balance in a geographic area with a particular sponsoring company, the consumer may not be interested in redeeming the points for any of the limited reward items in the geographic area offered by the company, the consumer may forget or ignore the existence of the point balance and/or the consumer may not desire to spend the time reviewing the reward items or completing the redemption information. In these exemplary situations, the loyalty point account may only be rarely used or may remain inactive.

[0007] The sponsoring company often maintains hundreds or thousands of loyalty point accounts for current and past consumers; however, possible public relations, marketing and legal implications exist with a sponsoring company simply canceling certain loyalty point accounts or setting expiration dates on points. As such, the sponsoring company usually continues to maintain the rarely used or inactive loyalty point accounts. However, accounting and legal guidelines typically require a sponsoring company to include all of the loyalty point balances, including balances from the rarely used loyalty point accounts, as liabilities on its accounting statements. As such, a need exists for a system and method for reducing or eliminating certain loyalty account balances and providing

certain consumers with new ways to aggregate and redeem geographic-based loyalty point balances.

SUMMARY OF INVENTION

[0008] The invention includes facilitating the substantially real-time pooling, gifting or transferring of geographic area loyalty points between accounts. The invention also facilitates a transfer of geographic area loyalty points from at least one consumer account associated with a sponsoring company to at least one consumer account associated with a host company. The invention may also facilitate gifting of loyalty points to charitable organizations on a recurring basis, wherein the gifting may transfer any portion of geographic based points to various charities. The charities may or may not be located in the same geographic area as where the loyalty points were earned. The system may also convert the geographic area loyalty points to a monetary value, thereby allowing the points to be donated to a charity such that the donation appears to be a monetary value donation to the charity.

[0009] More particularly, the invention includes a method for facilitating a transfer of loyalty points between at least two loyalty accounts, wherein the loyalty points are associated with a geographic area, by maintaining a database for storing geographic area loyalty points in at least one loyalty account corresponding to at least one consumer; receiving a transfer request to transfer a number of geographic area loyalty points from a first loyalty account to at least a second loyalty account; determining a geographic area related to the geographic area loyalty points requested for transfer; acquiring data related to a geographic area loyalty point balance of a first loyalty account; deducting a portion of the geographic area loyalty point balance of said first loyalty account; and, crediting a geographic area loyalty point balance of said second loyalty account. The transfer request may include, for example, receiving a request from a consumer associated with the first loyalty account, receiving a request from a consumer associated with the second loyalty account, receiving a request from a third party, receiving a request based upon a triggering event or receiving a request to return points to the first loyalty account. A triggering event may include, for example, a request, the first loyalty account having a geographic area loyalty point balance which is below a certain threshold amount, the first loyalty account remaining inactive for a certain time period, a predetermined time period, a certain date, a random date, a requested time, a certain formula, an event, a non-event, or a predetermined data point.

BRIEF DESCRIPTION OF DRAWINGS

[0010] A more complete understanding of the present invention may be derived by referring to the detailed description and claims when considered in connection with the Figures, wherein like reference numbers refer to similar elements throughout the Figures, and:

[0011] FIGS. 1, 3, and 4 are schematic block diagrams illustrating exemplary incentive systems in accordance with various aspects of the present invention;

[0012] FIG. 2 is a flowchart illustrating an exemplary process for instant enrollment at a point-of-sale in accordance with the invention;

[0013] FIG. 5 is a schematic block diagram of an exemplary central rewards mechanism in accordance with the present invention;

[0014] FIG. 6 is a schematic block diagram of an exemplary rewards server in accordance with the present invention;

[0015] FIG. 7 is a flowchart illustrating an exemplary process for capturing and processing POS SKU data in accordance with the present invention;

[0016] FIG. 8 is a flowchart illustrating an exemplary process for associating SKU data and UPC data in accordance with the present invention;

[0017] FIG. 9 is a schematic block diagram of an exemplary profiling system in accordance with the present invention;

[0018] FIG. 10 is a schematic block diagram of an exemplary profiler in accordance with the present invention;

[0019] FIG. 11 is a flowchart illustrating an exemplary process for generating a purchaser profile in accordance with the present invention; and

[0020] FIG. 12 is a flowchart illustrating an exemplary process for standardizing a transaction file in accordance with the present invention.

DETAILED DESCRIPTION

[0021] In general, the present invention includes facilitating the transfer, gifting and/or pooling of geographic area loyalty points between accounts. In an exemplary embodiment, the invention includes facilitating the substantially real-time transfer of loyalty points between accounts. Many consumers may transfer geographic area points to one consumer to thereby pool points.

[0022] The geographic area loyalty points may be earned in a first geographic area, so the system may include rules or restrictions related to the transferring, gifting or pooling of geographic area loyalty points based upon the existing geographic area loyalty points which may exist in the accounts. For example, points earned from New York retailers may only be combined with other points which were earned from New York City retailers. Similarly, in other embodiments, points earned from New York retailers may be combined with points earned in the Northeast region of the United States. In one embodiment, the geographic area designation of any portion of the transferred points may change based upon the geographic designation of all or any portion of the points within the recipient account. For example, a free New York restaurant certificate may require 20,000 points. However, if the consumer only has 19,000 New York points in his loyalty account, the consumer may request that a friend that has an extra 1,000 Arizona loyalty points in her account immediately transfer the 1,000 points to the consumer's loyalty account, thereby converting the geographic designation of the 1,000 Arizona points to 1,000 New York points to increase the total New York loyalty points in the consumer's loyalty account to 20,000 loyalty points, thereby allowing the consumer to immediately utilize the 20,000 New York loyalty points to obtain the New York restaurant certificate.

[0023] While the invention will be discussed in terms of a general transfer of geographic area loyalty points, one skilled in the art will appreciate that the transfer may include a deduction from a first account and a crediting of a second account with any type or portion of points (or points converted to another geographic designation). Moreover, the transfer may involve any portion of the points transferred in real-time, certain points transferred in a batch transfer, certain points transferred upon a triggering event, certain points transferred over time and/or certain points transferred upon satisfaction of a condition or rule.

[0024] In one embodiment, the system includes any hardware and/or software discussed herein or known in the art suitably configured for receiving a transfer request (e.g., consumer request, triggering event, etc) for a transfer of a any portion of geographic area loyalty points, accessing and analyzing the total number of geographic area loyalty points in the transferor account to determine if a sufficient number of points exist, analyzing the type/level of consumer and type/level of points to be involved in the transfer, determining if any rules exist for restricting or limiting the transfer of geographic area points, using a conversion engine to convert the point value or geographic area designation to an appropriate point value or geographic area designation in the transferee account, deducting the requested loyalty points from the transferor account, and increasing the point balance in the transferee account.

[0025] Loyalty points may be located in a consumer account wherein the consumer account may be associated with a consumer ID. As described herein in more detail, the consumer account and consumer ID may include any form of account or identification for an account. The consumer account may be associated with an organization, charity, a primary member, a supplementary member and/or more than one member. Certain consumer accounts may include aggregate consumer accounts which include a plurality of primary and/or supplementary members. As such, the transfer of points as discussed herein may include the transfer of points between primary and supplementary members, between primary members, between supplementary members, between a member and an organization and/or a member and a charity.

[0026] The consumers or loyalty points may be classified into various geographic areas, levels, classes or types such that the transfer of points may be limited to transferring points associated with certain geographic areas, between certain consumers only and/or between consumers in different levels, classes or types. For example, a Gold Club consumer may only be allowed to transfer Texas points to other Gold Club consumers having pre-existing Texas points in their accounts. In another embodiment, consumers associated with a certain organization or company can only transfer Kentucky points to other consumers associated with the same organization or company. For example, an IBM employee can transfer Kentucky points to another IBM employee, wherein the transferred points can still only be used in Kentucky. In another embodiment, a consumer may only be allowed to transfer certain geographic area points to the consumer's employer or to a charitable organization.

[0027] The geographic area loyalty point balance may be stored as a point total, a number, a letter, a level, a code, a value and/or the like. Moreover, the loyalty points may include various geographic areas, types, levels or classes of points such that the transfer of points may be limited to transferring only certain points between consumers. As such, while the point transfer is discussed herein with respect to deducting and increasing certain accounts, the invention contemplates that the transfer may include a conversion of points to another geographic area, type, level or class without (or in addition to) deducting or increasing points. For example, the system may allow a consumer to transfer level 1, Wyoming points to other consumers, but not allow the consumer to transfer level 2, Oklahoma points. When combined with other embodiments, the system may also allow only certain types of points to be transferred to only certain types of consumers. For example, only Seattle level 1 points may be transferred to

Gold Club consumers and only Los Angeles level 2 points may be transferred to Green Club consumers. In another embodiment, loyalty points associated with different geographic areas, levels, classes or types may all be freely transferable to any consumer.

[0028] In another exemplary embodiment, the present invention facilitates the transfer of any portion of loyalty point balances from at least one sponsored account which includes sponsored loyalty points to at least one host account associated with a particular host. As used herein, a "sponsoring company" includes any person, entity, software and/or hardware that facilitates the issuing of points to its consumers including a company (e.g., hotel, airline, car rental, transaction card issuer, charity) and/or parent organizations, joint ventures, affiliates, subsidiaries, co-marketers, co-sponsors, divisions and/or any related entities. As used herein, "sponsored loyalty points" include loyalty points associated with a sponsoring company. The sponsoring company may operate and sponsor a geographic area loyalty program by allowing consumers to earn geographic area loyalty points associated with the sponsoring company. The sponsoring company also maintains one or more geographic area loyalty point accounts for each consumer, wherein the system stores a balance of the sponsored loyalty points earned by the particular consumer. A "host" includes any person, entity, software, and/or hardware that receives the transferred geographic area loyalty points, facilitates the transfer of loyalty points and/or aggregates loyalty points associated with the same consumer. The host company may be another sponsoring company.

[0029] In accordance with the present invention, geographic area loyalty points associated with a certain geographic area loyalty system may also be transferred to other loyalty point accounts within the same geographic area loyalty system or to a loyalty point account in any other geographic area or in any other loyalty point system. For example, Hilton Reward, Dallas points may be transferred to a United Airlines frequent flyer account having Paris points. In one embodiment, a conversion engine facilitates any point value or geographic area conversions that may be appropriate. For example, if a consumer desires to transfer five hundred Hilton Reward, Dallas points to a United Airlines frequent flyer account having Paris points, the conversion engine may determine that the five hundred Hilton Rewards, Dallas points only translate into one hundred United Airlines frequent flyer Paris points. As such, the system would only increase the United Airlines frequent flyer account by one hundred Paris points. The rules or formulas associated with the conversion engine may be pre-established by the loyalty point system hosts. For additional details, see U.S. Ser. No. 10/378,456, filed on Mar. 3, 2003, by Antonucci, et al., and entitled "SYSTEM AND METHOD FOR REAL-TIME TRANSFER OF LOYALTY POINTS BETWEEN ACCOUNTS," which is hereby incorporated by reference.

[0030] The transfer of any portion of geographic area loyalty points in a consumer account may be initiated upon a triggering event such as, for example, a request by the transferor, a request by a transferee, a request by a loyalty system host, a request by a third party, a transfer on a certain date or time, a percentage of points transferred during certain time periods and/or an automatic transfer upon a pre-established condition or data point. For example, the system may include a pre-established condition that any New York points in excess of 100,000 New York points are automatically transferred to a supplementary account. In another embodiment,

upon each birthday of a certain child, the child's loyalty account is credited a certain amount and geographic area designation of points from the parent loyalty account. Similarly, on every employment yearly anniversary date, an employee may receive 50,000 Seattle loyalty points from her employer loyalty account. In another embodiment, a pre-established condition may be a transfer of geographic area loyalty points based upon input of public or private data points. For example, transferring 30,000 San Francisco loyalty points when the stock market rises above 10,000, company revenue exceeds \$2 million or the company stock hits \$20.

[0031] The transfer may also include certain conditions that must be met prior to, during and/or after the transfer. If certain conditions are not met, the transfer may be voided or expire and/or any portion of the loyalty points may be returned to the original transferor, to the loyalty system, to another consumer loyalty account or to any other third party. For example, after receiving transferred geographic area loyalty points, if the transferee does not earn a certain amount of the same geographic area loyalty points on her own, the transferred geographic area loyalty points are transferred to another supplementary member.

[0032] The consumer loyalty system and/or any other third party may also establish certain rules or criteria for determining which consumers or geographic area loyalty point accounts should participate in the transfer of geographic area points, the portion of points that are transferred, and which loyalty accounts should be credited with the transferred points. The rules may include a transfer of points upon, for example, consumer accounts having geographic area loyalty point balances which are below a certain threshold amount, consumer accounts which have remained inactive for a certain time period or a request by the consumer or a third party. For example, the system may store a rule that flags any account that includes less than 500 New York City points. Moreover, the system may allow a consumer to enter a webpage or call a customer service representative to request that the consumer's own account be flagged such that the system will transfer any requested number of geographic area loyalty points to a second loyalty account upon a certain condition related to setting the flag. The transfer of geographic area points may occur at any predetermined time periods, certain dates, random dates and/or only at a requested time. The amount and/or geographic area designation of points to transfer may include a set amount of points, all of the points, any subset of points, an increasing amount of points, a decreasing amount of points and/or an amount of points based upon a certain formula, event or non-event (e.g., transfer 500 Chicago points away from a consumer loyalty account for each month the consumer does not rent a car from a particular rental company).

[0033] The system may also credit any portion of the geographic area loyalty points to one or more loyalty point accounts. For example, the consumer may request that the geographic area loyalty points be transferred to an account associated with a family member, a friend, a charitable organization and/or the like. In this manner, while the individual consumer accounts include minimal amounts of points which are often insufficient for the individual consumer to utilize for any large reward item, the charitable organization may be able to acquire a large amount of points from numerous consumer accounts in order to obtain larger reward items.

[0034] After the system checks any established rules, the system determines which consumer accounts meet the rules. The system may then flag the particular accounts and send a list of consumer accounts which meet the rules to the host system. In another embodiment, the loyalty system may establish or activate accounts associated with other people or organizations that may receive the transferred points, such as, for example, a United Way account. In one embodiment, the system may notify the consumer of the transfer of the geographic area points and/or provide the consumer with the option to keep the consumer account open or to close the consumer account if all points are transferred to another account. The system may then eliminate, close, or flag as inactive the consumer account. By transferring the geographic area loyalty points from certain inactive consumer accounts to the accounts of consumers that desire the extra points, the loyalty system eliminates or reduces the number of geographic area loyalty point accounts from its system, thereby reducing the sponsoring company accounting liabilities and providing new options for the consumers to redeem the points or aggregated points in another loyalty program.

[0035] The invention also includes a geographic area loyalty point donation system. In one embodiment, loyalty points may be donated from a donor to a charity, wherein the donated points are converted to a monetary value or goods and services, prior to donation to the charity. In an alternative embodiment, a charity may accumulate loyalty points from many donors, then redeem the points for goods or services at a later time. The invention may also include an automatic bill payment enrollment system for recurring donations of geographic area loyalty points (or the monetary value of the points). The system links a Donation Portal to an enrollment site, thereby allowing consumers to automatically charge charitable donations on a recurring basis to the consumer's loyalty account which may be associated with a transaction card. For example, in one embodiment, the consumer may authorize and the system may implement a transfer of 1000 New York City points annually to a desired college and 200 Chicago loyalty points annually to another charity such as Save the Children. Alternatively, the member may authorize a 100 Phoenix point transfer or gift to a desired college and a 20 Denver point monthly transfer to a different charity.

[0036] In one embodiment, the invention uses a Donation Portal having databases that interface with government Internal Revenue Service databases such that the member may donate geographic area loyalty points to virtually any of the U.S. 501(c)(3) organizations for tax deduction purposes. In an alternative embodiment, a donor may donate geographic area loyalty points to any other desired organizations in the U.S. The system may also incorporate various filters or donation analysis software to comply with government guidelines such as, for example, The Office of Foreign Assets Control (OFAC) which outlines requirements for restricting donations being sent to terrorist organizations.

[0037] In another exemplary embodiment, the invention also includes functionality to facilitate employee gift matching by providing an email to the donor to confirm the donation. In that regard, the system allows an employee to donate geographic area loyalty points through the donation website and then submit its email receipt as documentation for an employer gift matching program. In various embodiments, the system may allow the employee to simply forward an email to its employer, allow the employee or employer to enter data into certain webpages, allow the employer to have

certain access rights to verify donations by an employee, or allow reports to employers in any desired format or medium. The invention may then allow the employer to automatically contribute corporate geographic area points or any other donation to the same charity through an employer matching program. The invention may also provide for automated donation verification with employers, whereby information related to employee donations are automatically forwarded to employers for verification purposes. For additional details, see, for example, U.S. Ser. No. 10/707,715, filed on Jan. 6, 2004, by Aviles, et al., and entitled "Donation System and Method," which is hereby incorporated by reference.

[0038] The system may also convert the geographic area loyalty points to a monetary value, thereby allowing the points to be donated to a charity such that the donation appears to be a monetary value donation to the charity. The system converts the geographic area loyalty points to a currency credit and posts the credit to a charity account, where the charity account is generally a financial transaction account, such as a charge card, that is used to facilitate a transaction. For additional details, see, for example, U.S. Ser. No. 09/834,478, filed on Apr. 13, 2001, by Chien, et al., and entitled "System and Method for Using Loyalty Points," which is hereby incorporated by reference.

[0039] The present invention also includes a system and method wherein loyalty points may be earned within a specific geographic location, then burned in one geographic location, a subset of locations or without restrictions. Similarly, the loyalty points may be earned in one geographic location, a subset of locations or without restrictions, then burned only in a specific geographic location. Details of the earn and burn process will be described in more detail below. Interaction with the system may include communication to customer service representatives, entry into webpages or any of the computing devices set forth herein. The financial or loyalty accounts may or may not be associated with any of the transaction accounts or cards set forth below.

[0040] The geographic features of the system may be implemented using new types of data collected during the transaction or using existing data that is typically collected in a transaction, wherein the existing data may also be associated with geographic areas such as, for example, zip codes, retailer identification codes, service establishment codes, SKU codes, UPC manufacturer codes and/or the like. The collected information may be associated with any previously known information to perform data analysis related to the loyalty program on a local or network level (described in more detail below).

[0041] The geographic information may be associated with the consumer, merchant, processing system and/or any other part of the overall system. For example, a consumer may have a home zip code in New Jersey with a work zip code in New York City, so the system may determine that the consumer still qualifies for reward points from merchants with zip codes based in New York City. The system may also determine that a "double point" promotion may apply to purchases of products originating from manufacturers in Tennessee. In a more complex embodiment, the system may encourage New Jersey residents to shop for soap products from an Arizona manufacturer (e.g., Dial Corporation) which are sold by a New York merchant. As such, the system may acquire, utilize and/or associate the consumer home zip code, the merchant building zip code, and the SKU information from the soap. In another embodiment, the rewards may have a theme related to

the city. For example, New Orleans awards may be related to Jazz shows and Mardi Gras activities, while New York City awards may be related to Broadway shows, dining and other entertainment or sports venues. The awards may also include full geographic "experiences" such as, for example, dinner, backstage passes, cocktails with the cast, and movie premiers.

[0042] The system may include online interfaces, dial-up interfaces through POS terminals or any of the other hardware, software and communications discussed herein. In one embodiment, the system is configured with one product platform with a modularized approach to facilitate the development of market specific rewards and communication materials. Particularly, any geographic location and associated merchants may be input into a version of the present invention such that the invention facilitates similar features and functions in any newly created geographic region. For example, the system may be fully functional with various merchants, rewards and residents in the Manhattan, N.Y. area. Different data may be inputted into the same system in order to facilitate similar functionality in the Phoenix, Ariz. area, along with creating rewards and marketing material related to Phoenix merchants.

[0043] In this regard, a participant may use a particular ID or password to access the system online, wherein the particular ID instructs the system to provide functions and marketing materials or displays related to the appropriate geographical region. For example, inputting ID #1234 into a web site may result in a web page displaying various rewards redeemable at various Manhattan merchants. Similarly, inputting ID #5678 into the same web site may result in a web page displaying various rewards redeemable at various Phoenix merchants. The transaction card of the present invention may include a dual purpose transaction device which combines geographic-based loyalty functionality, financial transaction functionality (e.g., charge card) and access functionality (e.g., access to public transportation, including payment of the transportation fare). The card may include one or more magnetic stripes related to each functionality. The card or other transponder device may alternatively include two different RFID signals for each functionality.

[0044] As used herein, a "geographic area" or similar terms may include all or any portion of any street, city, county, state, country, continent, region (e.g., SoHo district, Chinatown), or any other areas, including combinations or subsets of areas. The geographic areas may relate to any of the participants, products, services or identifications. The geographic areas may relate to any associated geographic area such as, for example, a geographic area associated with a participant's home residence, work residence, travel areas or the like. The geographic area may also be automatically established based on the geographic area where a participant is located at the time (or at any established time period) based on, for example, cellular phone caller location relative to cellular towers or a global positioning system. The geographic areas may also be associated with where the product is manufactured, distributed, sold or the like. Moreover, while certain embodiments may refer to only a specific geographic area for brevity, the invention also contemplates other similar embodiments for multiple geographic areas or subsets of areas.

[0045] As used herein, "participant" may include any user, person, entity, charitable organization, machine, hardware, software, merchant or business who accesses and uses the system of the invention, including consumers (such as pri-

many members and supplementary members of an aggregate consumer account), retailers, manufacturers, and third-party providers, including any subsets, groups or combinations thereof. Participants in the system may interact with one another either online or off-line. The terms “participant”, “purchaser”, “customer”, “consumer”, “primary member”, and “end-user” may be used interchangeably with each other, and each shall mean any person, entity, charitable organization, or business which uses a consumer ID to participate in the present system. The participant may reside in a geographic area and work in a different geographic area.

[0046] As used herein, the term “online” refers to interactive communications that take place between participants who are remotely located from one another, including communication through any of the networks or communications means described herein or the like.

[0047] The term “manufacturer” shall include any participant, person, entity, charitable organization, machine, software, hardware, and/or the like that manufactures, distributes, or originates a product or service which may ultimately be offered to a consumer directly or indirectly through a retailer. The term “manufacturer” may also include any party that generates and/or provides manufacturer item identifiers. The manufacturer item identifier may include information related to the geographic area of the item or the geographic area of the manufacturer’s manufacturing plant, headquarters or divisions.

[0048] The term “retailer” shall include any person, entity, charitable organization, machine, software, hardware, and/or the like that offers a product or service to a consumer. As used herein, the term “retailer” is used interchangeably with the term “merchant”. Moreover, in this context, a retailer or merchant may offer or sell, either online or offline, products and/or services made or supplied by at least one manufacturer. The retailer or any distributors, suppliers, affiliates, franchises and the like may be located in one or more geographic areas.

[0049] As used herein, the phrases “network level” and “network-wide level” shall refer to a system that includes more than one retailer.

[0050] A “consumer ID”, as used herein, includes any device, code, or other identifier suitably configured to allow a consumer to interact or communicate with the system, such as, for example, a rewards card, charge card, credit card, debit card, prepaid card, telephone card, smart card, magnetic stripe card, bar code card, authorization/access code, personal identification number (PIN), Internet code, or other identification code, signal or indicia. Additionally, a “consumer ID” may comprise any form of electronic, radio frequency, transponder, magnetic, and/or optical device capable of transmitting or downloading data from itself to a second device which is capable of interacting and communicating with such forms of consumer ID.

[0051] “Consumer enrollment data” may comprise any of the following: name; address; zip code; home geographic area; work geographic area; date of birth; social security number; email address; gender; the names of any household members; a credit card number for charging any fees that may be associated with participation in the system; survey data; interests; educational level; spending trends; and/or any preferred brand names. A consumer may register to participate in the present system by any methods known and practiced in the art. For example, a consumer may be enrolled automatically (e.g., if the consumer holds an existing consumer

account with the system administrator), over the phone, at the point of sale (e.g., through a paper application, a verbal interview, or instant enrollment using a retailer loyalty identifier, as described herein), through the mail, or through instant enrollment online. Upon enrollment, the consumer receives a consumer ID that is associated with a consumer account. Enrollment data may be updated periodically, either by the consumer requesting that the data be updated to reflect changes or additions or the system requesting that the consumer review and update the data as needed, for example.

[0052] As used herein, a “retailer loyalty identifier” may include any device, code, or other identifier which permits a consumer to interact or communicate with a retailer system, including a retailer terminal, and indicate their participation in a retailer loyalty program which may be offered by a particular retailer or a group of retailers. Exemplary retailer loyalty identifiers may comprise any of the following: a rewards card, charge card, credit card, debit card, prepaid card, telephone card, smart card, magnetic stripe card, bar code card, authorization/access code, personal identification number (PIN), Internet code, other identification code, radio frequency card and/or the like. Additionally, a retailer loyalty identifier may comprise any form of plastic, electronic, magnetic, radio frequency, audio and/or optical device capable of transmitting or down-loading data from itself to a second device which is capable of interacting and communicating with such retailer loyalty identifiers.

[0053] As used herein, a “consumer account” shall mean any account which specifies a consumer as a holder of the account and which posts, records, stores, or tracks a consumer’s activity that is related to participation in the loyalty program. In one embodiment, the consumer account may post or record any of the following types of information: purchasing activity (e.g., items purchased and/or purchase amounts), reward points earning activity, reward points redemption activity, bonus offerings activity, and the like.

[0054] In accordance with one aspect of the invention, the consumer ID may be associated with an aggregate consumer account which specifies the consumer as a primary member and permits the association of any number of supplementary members with the primary member. In one embodiment, supplementary members are affiliated with the primary member, such as by being a member of the primary member’s household, business, organization, and the like. In another embodiment, supplementary members are selected by the primary member for association with the primary member’s aggregate consumer account on any basis deemed suitable by the primary member. For example, a primary member may associate friends, co-workers, family members, or any other group of individuals or entities. In one embodiment, both primary members and supplementary members may earn and redeem reward points which are posted to the aggregate consumer account or to any of several accounts that may be associated with the aggregate consumer account. In another embodiment, a supplementary member may only redeem reward points which that particular supplementary member has earned. In a further embodiment, a supplementary member may only redeem a quantity of reward points which the primary member has authorized for redemption by that particular supplementary member. The primary and supplementary members may be associated with the same, overlapping or different geographic areas.

[0055] As used herein, the phrase “aggregate consumer account” shall mean any account which specifies a primary

member and permits the association of any number of supplementary members with the primary member. In one embodiment, an aggregate account may be the sole account that associates the primary member with the supplementary members and reflects the activity of the primary member and any supplementary members. In another embodiment, an aggregate consumer account may be associated with multiple accounts that may each be associated with a supplementary member. For example, an aggregate consumer account may aggregate and post, record, store, or track all relevant activity engaged in by the primary member and any supplementary members that are associated with the aggregate consumer account. This aggregate activity may be reported solely to the primary member. Further, each supplementary member may be associated with a sub-account which posts only activity engaged in by the particular supplementary member. The activity in this sub-account may be reported only to the supplementary member associated with the sub-account. In this manner, the primary member may oversee the activity of each of the supplementary members, but each of the supplementary members cannot oversee the activity of either the primary member or other supplementary members.

[0056] The phrase “supplementary member” shall mean any person, entity, charitable organization, or business which uses a supplementary member ID to participate in the present system. It will be appreciated that, in certain contexts, the phrase “supplementary member” may be used interchangeably with the terms “purchaser”, “customer”, “consumer”, and “end-user”, since a “supplementary member” is a particular type of “consumer”. A “supplementary member ID”, as used herein, includes any device, code, or other identifier suitably configured to allow a supplementary member to interact or communicate with the system, such as, for example, a rewards card, charge card, credit card, debit card, prepaid card, telephone card, smart card, magnetic stripe card, bar code card, authorization/access code, personal identification number (PIN), Internet code, other identification code, and/or the like. Additionally, a “supplementary member ID” may comprise any form of electronic, magnetic, and/or optical device capable of transmitting or downloading data from itself to a second device which is capable of interacting and communicating with such forms of supplementary member ID.

[0057] A supplementary member may be registered to participate in the present system by any methods known and practiced in the art. In one embodiment, a supplementary member is registered by a primary member. For example, a supplementary member may be enrolled by a primary member over the phone, at the point of sale (e.g., through a paper application, verbal interview, or instant enrollment using a retailer loyalty identifier), through the mail, or through instant enrollment online. In another embodiment, a supplementary member is authorized to register by a primary member, and the supplementary member self-enrolls in view of the authorization. For example, a primary member may provide the system administrator with some indicia of authority to process the registration of a supplementary member, if and when the authorized supplementary member chooses to enroll in the system. The indicia of authority may include any suitable information, such as, for example, any of the following information regarding the supplementary member: name, address, social security number, employee number, date of birth, and the like. Supplementary member enrollment data may comprise any of the following: name; address; zip code; home

geographic area; work geographic area; date of birth; social security number; email address; gender; a credit card number for charging any fees that may be associated with participation in the system; survey data; interests; educational level; and/or any preferred brand names. Upon enrollment, the supplementary member receives a supplementary member ID which is associated with the primary member's aggregate consumer account. In one embodiment, the supplementary member ID may also be associated with, related to, identical to, contain a portion of, or expand upon the primary member's consumer ID.

[0058] A “consumer profile”, as used herein, shall refer to any data used to characterize a consumer and/or the behavior of a consumer. In the context of a commercial transaction, “a consumer profile” shall be understood to include, for example, the time and date of a particular purchase, the frequency of purchases, the volume/quantity of purchases, the transaction size (price), and/or the like. Additionally, in other transactional contexts, the term “consumer profile” shall also be understood to include non-purchase behaviors of a consumer, such as consumer enrollment data, visiting a Web site, referrals of prospective participants in the system, completion of a survey or other information gathering instrument, and/or the like. For instance, a participating online consumer may earn reward points automatically through a triggering event, such as visiting a Web site, completing an online survey, or clicking on a banner advertisement for example. Offline, a participating consumer may earn reward points by completing a task or showing their consumer ID to the cashier and triggering the cashier to provide a “behavior” ID which may be input (e.g. by scanning a bar code on a paper survey for example) into the POS terminal. Further, any aspects of the consumer profile may be used in the context of data analysis.

[0059] A “supplementary member profile”, as used herein, shall refer to any data used to characterize a supplementary member and/or the behavior of a supplementary member. In the context of a commercial transaction, “a supplementary member profile” shall be understood to include, for example, the time and date of a particular purchase, the frequency of purchases, the volume/quantity of purchases, the transaction size (price), and/or the like. Additionally, in other transactional contexts, the term “supplementary member profile” shall also be understood to include non-purchase behaviors of a supplementary member, such as supplementary member enrollment data, visiting a Web site, referrals of prospective participants in the system, completion of a survey or other information gathering instrument, and/or the like. For instance, a participating online supplementary member may earn reward points automatically through a triggering event, such as visiting a Web site, completing an online survey, or clicking on a banner advertisement for example. Offline, a participating supplementary member may earn reward points by completing a task or showing their supplementary member ID to a cashier and triggering the cashier to provide a “behavior” ID which may be input (e.g., by scanning a bar code on a paper survey for example) into the POS terminal. Further, any aspects of the supplementary member profile may be used in the context of data analysis.

[0060] A “third-party provider” may comprise any additional provider of goods and/or services to a consumer. Specifically, a “third-party provider” includes any party other than the particular manufacturer and retailer who is involved in a transaction with a consumer. A third-party provider may include, for example, a financial institution, such as a bank or

an issuer of a financial instrument (such as a credit card or a debit card). A third-party provider may also include a provider of goods and services which are offered as awards to consumers in exchange for a requisite number of reward points.

[0061] Though the invention may generically be described with reference to a series of transactions which transfer a good or service from an originating party to an intermediary party and a subsequent transaction which transfers the good or service from the intermediary party to an end-user of that good or service, for convenience and purposes of brevity and consistency, the present disclosure generally refers to the originating party as a “manufacturer”, the intermediary party as a “retailer”, the end-user as a “consumer” (including primary members and/or supplementary members), and a good or service as a “product” or “item”. However, it will be recognized by those of ordinary skill in the art that the retailer need not provide a product or item to a consumer in exchange for monetary currency. While this often may be the case, the present disclosure is not so limited and includes transactions which may be gratuitous in nature, whereby the retailer transfers a product or item to a consumer without the consumer providing any currency or other value in exchange. It is further noted that additional participants, referred to as third-party providers, may be involved in some phases of the transaction, though these participants are not shown. Exemplary third-party providers may include financial institutions, such as banks, credit card companies, card sponsoring companies, or issuers of credit who may be under contract with financial institutions. It will be appreciated that any number of consumers, retailers, manufacturers, third-party providers, and the like may participate in the system of the present invention.

[0062] As used herein, the term “UPC” and the phrase “manufacturer item identifier” shall refer to any symbol or indicia which provides information and, in an exemplary embodiment, shall refer to any number, code, or identifier assigned by a manufacturer and associated with an item, including any type of goods and/or services, ultimately offered to a consumer or other end-user. The UPC may include geographic area information related to the origin of the product, where the product is being sold, the various geographic areas the product is distributed and/or the like.

[0063] A UPC is sometimes referred to as a SKU number. However, as used herein, the term “SKU” and the phrase “retailer item identifier” shall refer to any symbol or indicia which provides additional information and, in an exemplary embodiment, shall refer to any number, code, or identifier assigned by a retailer and associated with an item, including any type of goods and/or services, offered to a consumer or other end-user (such as a supplementary member for example). The SKU may include geographic area information related to the origin of the product, where the product is being sold, the various geographic areas the product is distributed and/or the like.

[0064] “Purchase data”, as used herein, comprises data relating to the offer of any item to a consumer, supplementary member, or other user of goods and/or services. Purchase data may include data regarding any or all of the following: geographic area of purchase, an item purchased; an item price; a number of items purchased; a total transaction price; a payment vehicle (e.g., cash, credit card, debit card, check, etc.); a time, date, and/or day of the week associated with a purchase; a store identifier; an employee identifier; a retailer item identifier; a loyalty identifier; a retailer loyalty identifier; a con-

sumer’s use of (which includes a reference to) a marketing offer (e.g., a coupon, a bonus offering, reward points, etc.); whether a purchase transaction takes place online or offline; and/or the like. In one embodiment, purchase data may also include any data relating to a product or service warranty that may apply to a purchased item. Such “warranty data” may include any of the following: the duration of the manufacturer’s warranty, the scope of the warranty (e.g., limitations that may apply), any consumer purchased extensions of the manufacturer’s warranty, and the like.

[0065] “Retailer ID”, as used herein, comprises any symbol, indicia, code, number, or other identifier that may be associated with a retailer of any type of goods and/or services offered to a consumer, supplementary member, or other end-user. A retailer ID may also include or be associated with a “store ID”, which designates the geographic area of a particular store.

[0066] A “manufacturer ID” comprises any symbol, indicia, code, number, or other identifier that may be associated with a manufacturer of any type of goods and/or services ultimately offered to a consumer, supplementary member, or other end-user. A manufacturer ID may also include geographic area information related to the location of a manufacturer (e.g., headquarters, manufacturing facility), distributors, suppliers or the like.

[0067] An “award” or “reward” may comprise any quantity of products, services, coupons, gift certificates, rebates, reward points, bonus points, credits or debits to a financial instrument, entertainment packages, theme packages of items, any combination of these, and/or the like.

[0068] A “purchaser profile”, as used herein, shall refer to and/or include any data used to characterize a consumer and/or the behavior of a consumer and may be derived from other data, such as, for example, geographic area information, consumer enrollment data and purchase data. A “purchaser profile” may include, and/or convey information regarding, any or all of the following: consumer enrollment data; the time, date, and/or day of the week of a particular purchase; the item(s) purchased; the price of the item(s) purchased; the purchase frequency for particular items; the volume/quantity of purchases, either in terms of total dollars spent or item quantities; spend levels over the course of a given time period; spend levels for a given category of products; responses to marketing offers; whether purchases were made online or offline; the transaction size (price); a purchaser’s brand preferences; a retailer item identifier; a manufacturer item identifier; the existence and terms of a product warranty associated with an item purchased; the status (e.g., current or almost expired) of a product warranty associated with a purchased item; geographic area information related to any of the foregoing information, and/or the like. It will be appreciated that while particular types of data may be described herein as either “purchase data” or “enrollment data”, these categories of data need not be exclusive of one another and may overlap. For example, in alternate embodiments of the invention, data types that may be described herein as “purchase data” may be included as “enrollment data”, and data types that may be described herein as “enrollment data” may be included as “purchase data”. Moreover, in further embodiments, data types that are described herein as being a part of one of these data categories may, instead, be a part of the other data category.

[0069] “Data analysis”, as used herein, shall be understood to comprise quantitative and qualitative research, statistical

modeling, regression analyses, market segmentation analyses, econometrics, and/or the like. Such analyses may be used to characterize a consumer, predict a consumer's behavior, and/or correlate any of the following: a consumer profile, a part of a consumer profile, a supplementary member profile, a part of a supplementary member profile, consumer enrollment data, purchase data, retailer data, manufacturer data, product or service data, and/or the like.

[0070] Since rewards, which may be in the form of reward points, may be earned across the various tiers and geographic areas in the network, rewards may also be used or spent across the various tiers and geographic areas in the network. Thus, any reward points that an employee, for example, may earn by promoting a particular manufacturer's line of products, may be "spent" by that employee on goods or services provided by any participant in the network, not merely at the retailer who employs that employee. Likewise, any reward points earned by a consumer may be spent on goods or services offered by any participant in the network. However, the earning or burning of the points may include geographic rules or restrictions.

[0071] In accordance with another aspect of the invention, the use of geographic based loyalty points or rewards by the system facilitates data analysis on a network level based upon several factors, including any of the following: geographic area, consumer ID, consumer profile, supplementary member ID, supplementary member profile, retailer ID, SKU number, UPC, manufacturer ID, and/or the like. The system may compile any of the above data across multiple participants for the purpose of data analysis, such as analyses which may be employed in strategic planning and marketing for example. The system of the invention may be used to compile, analyze, and report data in a manner which would inform any or all network participants that, for example, a specific consumer (1) has made multiple purchases of particular manufacturers' products in a certain geographic area; (2) has spent Q dollars over a certain time period in a certain geographic area; (3) at specific multiple retailers in certain geographic areas; and (4) of the purchases made, R dollars went towards the purchase of Product 1 manufactured in a certain geographic area, S dollars went towards the purchase of Product 2 sold in a certain geographic area, and T dollars went towards the purchase of Service 1 offered in a certain geographic area. Moreover, the system may be used to compile, analyze, and report data that enable a retailer, a manufacturer, and/or a third-party provider to create a variety of targeted marketing promotions, such as, for example, (1) marketing Product 1 offered by Manufacturer 1 to consumers in a certain geographic area who purchase Product 2 offered by Manufacturer 2; (2) marketing Product 1 offered by Manufacturer 1 and sold by Retailer X to consumers in a certain geographic area who purchase Product 2 offered by Manufacturer 2 at Retailer Y; and/or (3) marketing Product 1 offered by Manufacturer 1 and sold by Retailer X to consumers in a certain geographic area who purchase Product 2 offered by Manufacturer 2 at Retailer Y five times a year. It will be appreciated that these are but a few of the many possible applications for data gathered and generated by the system of the present invention.

[0072] In accordance with a further aspect of the invention, the system administrator may allocate reward points to participants in the system. The reward points may be associated with a particular geographic area. In one embodiment, participating retailers and/or manufacturers in a certain geographic area may purchase geographic area specific points from the system administrator and the points are then allo-

cated to an account associated with the retailer and/or manufacturer. For example, a New York City retailer near Broadway may purchase 1,000 points which, when a sufficient number are collected, entitle the consumer to a free Broadway show next to the retailer's place of business. In an alternate embodiment, the system administrator may give or donate points to participating retailers and/or manufacturers. The system administrator maintains an account with each of the participating retailers and manufacturers and tracks available points balances and/or balances owing on a rolling basis. The points purchased by the retailers and/or manufacturers may then be earned by and issued to consumers in a manner that is predetermined by the retailer and/or manufacturer involved in the transaction with the consumer. For example, Retailer 1 may purchase 10,000 points from the system administrator and then offer consumers 1 point for every \$10 dollars spent in Retailer 1's store or, perhaps, some number of points for every fifth transaction in the store. Moreover, Manufacturer 1 located in Michigan, who produces the product offered by Retailer 1 in Michigan, may also purchase points from the system administrator. Thus, when a consumer purchases Manufacturer 1's product at Retailer 1, Manufacturer 1 may issue some number of points to the consumer, wherein the points entitle the consumer to a free dinner at a Detroit restaurant. The issuance of points, either by retailers or manufacturers, may be based upon any selected criteria, including a points-for-dollars ratio or percentage, a defined quantity of points per item or per transaction, some combination of these, and/or the like. The issuance of points may also include ratios based upon geographic area. For example, 1000 points to be redeemed in Detroit may be purchased for \$1000, but the same 1000 points to be redeemed in New York City may cost \$2000 because the rewards may be more expensive (e.g., more expensive for a dinner).

[0073] The system administrator maintains an account for each participating consumer and apprises the consumer of the points totals and account activity. The consumer may have one (or a subset of accounts) which include points associated with different geographic areas or separate accounts for each geographic area. The consumer may search or view points based upon geographic area designation or combinations of designations. The system may allow the consumer to transfer points from one geographic area designation to another geographic area designation or combine points from different designations, wherein the transfer or combining may include a transfer ratio. For example, the consumer may only be allowed to transfer 1000 New York City points to 500 Denver points. The consumer may review the total number of points in the account either online or off-line, such as through a periodic statement sent by the system administrator or through the use of a communications network, such as the Internet, for example. Points in the consumer's account may be accumulated across the multiple retailers and/or manufacturers participating in the system and the accumulation may be limited to combining points from similar geographic areas. Thus, points earned by a consumer based upon transactions with different retailers and/or manufacturers in the same geographic area may be combined, resulting in a rapid accrual of points.

[0074] The system administrator offers a catalog of products and services related to different geographic areas, which may be either online or off-line, from which consumers may select rewards in exchange for the applicable accrued points. In this manner, consumers advantageously earn points based

upon their everyday purchases of products and services in a certain geographic area, these points are accrued across retailers and/or manufacturers in a certain geographic area, and points redemption takes place through a catalog of rewards from the same geographic area.

[0075] In accordance with another aspect of the invention, the system administrator may maintain an aggregate consumer account for a participating consumer (primary member) regardless of the geographic area where the points are, or may be, earned. The aggregate consumer account is established, for example, by the primary member, who enrolls or permits enrollment of any number of supplementary members who are identified by the primary member, wherein the supplementary members may obtain points in the same or different geographic area as the primary member. In one embodiment, a consumer may establish an aggregate consumer account to encompass members of the primary member's household, business, charitable organization, and the like. In another embodiment, supplementary members are selected by the primary member for association with the primary member's aggregate consumer account on any basis deemed suitable by the primary member. For example, a primary member may associate friends, co-workers, family members, or any other group of individuals or entities in the same or different geographic area as the primary member. In one embodiment, each supplementary member is associated with a supplementary member ID number, which uniquely identifies the supplementary member (e.g., as Supplementary Member 1, Supplementary Member 2, etc.) and which affiliates the supplementary member with the primary member, a geographic area associated with the primary member, the primary member's consumer ID, and/or the primary member's aggregate consumer account. As discussed herein, the supplementary member accounts may be aggregated or divided by geographic area.

[0076] In accordance with an exemplary embodiment, supplementary members may both earn reward points and redeem reward points based upon their participation in the system of the invention. In one embodiment, the supplementary member ID is used to identify reward points earning transactions and reward points redemption transactions engaged in by a particular supplementary member, as distinguished from transactions engaged in by the primary member or other supplementary members of the aggregate consumer account. In this manner, the aggregate consumer account may track aggregate points totals and account activity for all members (primary and supplementary) of the aggregate consumer account as well as track particular point totals and account activity for each member (primary and supplementary) of the aggregate consumer account. In one embodiment, a primary member may redeem all or any of the reward points accumulated in the aggregate consumer account in the same or different geographic area as the supplementary members. In another embodiment, a primary member may designate a particular supplementary member(s) as eligible to redeem any or all of the reward points in the aggregate consumer account and the primary member or any other participant may limit the redemption to a specific geographic area. In a further embodiment, each supplementary member may redeem those reward points which have been earned by the particular supplementary member in a specific geographic area. In still another embodiment, a supplementary member may only redeem a quantity of reward points which the primary member has authorized for redemption by that particular supple-

mentary member in a specific geographic area. In yet another embodiment, a first supplementary member may designate a second supplementary member as eligible to redeem in a specific geographic area any or all of the reward points earned by the first supplementary member in a specific geographic area.

[0077] In accordance with an aspect of the invention, a consumer may review the total number of points in an account either online or off-line, such as through a periodic statement sent by the system administrator or through the use of a communications network, such as the Internet, for example. Points in the consumer's account are accumulated across the multiple retailers and/or manufacturers participating in the system. Thus, points earned by a consumer based upon transactions with different retailers and/or manufacturers in a specific geographic area are combined, resulting in a rapid accrual of points. The system administrator offers a catalog of products and services, which may be either online or off-line, from which consumers may select rewards in exchange for accrued points. In this manner, consumers advantageously earn points based upon their everyday purchases of products and services in a specific geographic area, and these points are accrued across retailers and/or manufacturers in a specific geographic area.

[0078] In one embodiment, a consumer may redeem earned points through a specific geographic area catalog of rewards, which may include products and services offered by any number of merchants in a specific geographic area, which merchants may or may not be participants in the system. The catalog may be offered to the consumer in both online and offline formats. In another embodiment, a consumer may redeem earned points through a customized online catalog, which presents to the consumer a sub-set of rewards from the catalog in a specific geographic area that are particularly relevant to the consumer. The relevance of particular rewards to the consumer may be defined based upon any suitable criteria, such as the consumer's self-characterization (such as by indicating and inputting particular demographics information through a suitable user interface, as is well-known and practiced in the art) or the consumer's reward points total in a specific geographic area, for example. The customized online catalog may also include products and services offered by any number of merchants in a specific geographic area.

[0079] In accordance with another aspect of the invention, a primary member may permit a supplementary member to access and review, through the use of a suitable communications network (such as the Internet for example), the total number of points in any geographic area in an aggregate consumer account. Alternatively, a primary member may permit a supplementary member to access and review only the number of points earned by that particular supplementary member in a specific geographic area. As with primary members, points earned by supplementary members are accumulated across the multiple retailers and/or manufacturers in a specific geographic area participating in the system. Thus, points earned by a supplementary member based upon transactions with different retailers and/or manufacturers in a specific geographic area are combined, resulting in a rapid accrual of points.

[0080] In one embodiment, supplementary members may redeem accumulated reward points through the above-described catalog as well as the customized online catalog. Alternatively, supplementary members may redeem reward points at one or more sub-catalogs for a specific geographic

area that may target a particular type of supplementary member in a specific geographic area. The type of supplementary member targeted by a sub-catalog may be defined by any suitable criteria, such as the specific geographic area of the member or where the points were earned, capacity for lesser or greater point accumulation, consumer market segment, demographics information, products related to or similar to previously purchased products, profile information, and the like. Examples of the types of supplementary members may include younger household members, such as children or teenagers for example; particular classes or categories of employees, such as staff members or senior executives; members of a charitable organization, such as volunteers or officers of the Board of Directors; and the like. In one embodiment, a sub-catalog may offer items having a lower monetary value in a specific geographic area (as reflected in the redemption points value of the offered items) than items offered in the catalog. In another embodiment, each supplementary member's accumulated reward points total in a specific geographic area is matched, according to a volume of total points, with a corresponding sub-catalog in a specific geographic area, and a supplementary member who seeks to redeem accumulated reward points is automatically directed to that particular sub-catalog in response to a request for redemption. In one embodiment, any reward points redemption transactions by a supplementary member in a specific geographic area results in a corresponding reduction in the aggregate accumulated reward points total of the aggregate consumer account in a specific geographic area as well as a reduction of the particular supplementary member's reward points total in a specific geographic area.

[0081] In accordance with the present invention, FIG. 1 is a diagram illustrating an exemplary embodiment of an incentive or loyalty system **100**. System **100** comprises a central rewards mechanism **102**; a plurality of retailer/merchant systems **104**; and at least one manufacturer **106**. One skilled in the art will appreciate that system **100** may comprise any number of retailer systems **104** and any number of manufacturers **106**.

[0082] The central rewards mechanism **102** manages the incentive or loyalty program of system **100**. In an exemplary embodiment, central rewards mechanism **102** receives, processes, and stores manufacturer data, such as information regarding products, services, geographic area information and UPC data, transmitted by manufacturers **106** who have enrolled in the system **100**. Manufacturers **106** may transmit data to central rewards mechanism **102** in any form and by any means known in the art, including any of the communications means described herein. The manufacturer data is stored by the central rewards mechanism **102** in database **103**. As described in further detail below, database **103** may be any type of database, such as relational, hierarchical, object-oriented, and/or the like. Common database products that may be used to implement database **103** include DB2 by IBM (White Plains, N.Y.), any of the database products available from Oracle Corporation (Redwood Shores, Calif.), Microsoft Access by Microsoft Corporation (Redmond, Wash.), or any other database product. Database **103** may be organized in any suitable manner, including as data tables or lookup tables.

[0083] The central rewards mechanism **102** may receive and process, geographic area information, consumer ID or supplementary member ID information and purchase data from any of the retailer systems **104**. The central rewards

mechanism **102** may also associate a particular consumer ID or supplementary member ID with the geographic area information, purchase data and a corresponding manufacturer item identifier. In one embodiment, the central rewards mechanism **102** performs an analysis involving one or more of the following: geographic area information, a consumer ID, a supplementary member ID, purchase data, a points ratio, a consumer profile, a supplementary member profile, a retailer ID, and a manufacturer ID. The analysis may be dependent upon an association of the consumer ID or supplementary member ID, the purchase data, and the manufacturer item identifier. The analysis may further comprise, for example, geographic area information analysis using a calculation of reward points and/or other analyses for purposes of market segmentation in a geographic area, determining consumer spending behavior in a geographic area, correlating spending behavior in a geographic area and consumer demographics in a geographic area, and/or the like, as described in greater detail above.

[0084] In one exemplary embodiment, the central rewards mechanism **102** stores and informs a consumer of the reward points that have been earned by a particular transaction in a geographic area as well as accumulated over time in various geographic areas. The number of reward points calculated and awarded by the central rewards mechanism **102** for a particular purchase may depend upon a geographic area and/or a predetermined rewards ratio. The rewards ratio may be determined by the retailer, the system administrator, the manufacturer of the purchased item, and/or any other suitable third-party. For example, if a participating consumer buys a product from a retailer for \$100 and if the retailer rewards ratio is one reward point for each dollar of the purchase price (i.e., one-for-one), once the consumer's consumer ID or supplementary member ID is identified by the system, the consumer is credited with a suitable number of reward points from the retailer, which, in this case, would be 100 points. However, if the manufacturer also chooses to issue reward points for the item purchased, the manufacturer may select a points ratio that is different from the retailer's selected ratio. In the illustrated example, if the manufacturer's selected points ratio is two-for-one, then the consumer will be awarded an additional 200 points from the manufacturer for this single \$100 purchase. Additionally, if the product is purchased in a certain geographic area, the points ratio may be different. For example, if the product is purchased in Ohio, the consumer is awarded a three-to-one ratio, but if the product is purchased in Arizona, the consumer may only receive a two-to-one ratio. In this manner, the system of the invention may provide "earn accelerators" through which consumers may accumulate reward points at a comparatively rapid rate. In other words, a single purchase in a geographic area may generate reward points for a consumer from any or all of a retailer, a manufacturer, and/or a third-party provider, and those reward points may be used as rewards currency by the consumer throughout the network established by the system of the invention.

[0085] In an exemplary embodiment, retailer system **104** comprises a retailer terminal **108** and a retailer processor **110** in communication with database **111**. Retailer terminal **108** comprises any input device capable of identifying a consumer ID or a supplementary member ID. Exemplary devices for identifying a consumer ID or supplementary member ID may include: a conventional card reader which recognizes a magnetic stripe or bar code associated with a consumer ID or

supplementary member ID; a biometric device; a radio frequency device; a smart card reader which recognizes information stored on a microchip integrated with a consumer ID or supplementary member ID; any device capable of receiving or uploading consumer ID or supplementary member ID data transmitted electronically, magnetically, optically; and/or the like. In one embodiment, retailer terminal **108** and retailer processor **110** are co-located at a retail store. In another embodiment, retail terminal **108** and retailer processor **110** are remote from each other.

[0086] In one aspect of the invention, as illustrated in FIG. 2, the retailer system **104** may facilitate instant enrollment in the system of the invention by a consumer at the point of sale. In an exemplary embodiment, retailer terminal **108** comprises an input device, such as any of the devices noted above for example, that is capable of identifying a retailer loyalty identifier, which is described in detail above. In this embodiment, when a consumer uses their retailer loyalty identifier at a retailer point-of-sale checkout (which may be either at a brick and mortar establishment or an online retailer Web site) (step **202**), the consumer is asked whether they wish to enroll in the system of the invention (step **204**). In an exemplary embodiment, the retailer terminal **108** and/or the input device which interacts with the retailer loyalty identifier presents an enrollment query (e.g., “Would you like to enroll in a networked loyalty program?”) and prompts the consumer (or a retailer employee who may be handling the checkout transaction) to indicate a response by, for example, selecting either “Yes or No” in response to the enrollment query. In one embodiment, the consumer uses the retailer loyalty identifier to interact with the input device while the consumer’s purchases are being checked-out by the retailer so that pull-through rates are minimally impacted. For example, the consumer may swipe or scan the retailer loyalty identifier while the retailer is performing the checkout process, and therefore the consumer may respond to the enrollment query substantially without the aid of the retailer employee who is performing the checkout.

[0087] If the consumer does not wish to participate in the loyalty program of the invention, the consumer selects “No” in response to the enrollment query, the negative response is communicated to the retailer system **104**, the retailer regional processor **114**, and/or the central rewards mechanism **102** (step **206**), and the checkout process proceeds as usual (step **208**).

[0088] Alternatively, if the consumer wishes to participate in the loyalty program of the invention, the consumer selects “Yes” in response to the enrollment query, and the affirmative response is communicated to the retailer system **104**, the retailer regional processor **114**, and/or the central rewards mechanism **102** (step **210**). In this embodiment, the checkout also proceeds as usual (step **212**). However, retailer enrollment data pertaining to the consumer is communicated from the retailer system **104** (or the retailer regional processor **114**, as described herein with reference to FIG. 4) to the central rewards mechanism **102** (step **214**). For example, retailer enrollment data, such as, for example, the consumer’s name, address, geographic area information, etc., which the retailer has previously gathered from the consumer and has processed and stored for the purpose of enabling the consumer to participate in the retailers independent loyalty program, is sent from the retailer system **104** (or the retailer regional processor **114**) to the central rewards mechanism **102**.

[0089] At this point, the consumer may be able to establish (or it may be established by the retailer, the system or other participant) a main geographic area indicating the “primary” area in which the consumer wishes to establish for receiving or spending geographic-based rewards. The consumer may also be able to select a secondary area for receiving or spending geographic-based rewards. For example, if the consumer spends most of the year in Chicago, but the winters in Florida, the consumer may select Chicago as a primary area and Florida as a secondary area. Furthermore, the system may offer options to select regions of participation (similar to wireless phone service areas). The system may automatically establish the geographic area of the participant based on the use of, for example, cellular phone caller location relative to cellular towers or a global positioning system which may communicate the location (previous or planned locations) of the participant to the system. For example, the GPS may communicate that the consumer recently traveled from Maine to New York, so the system may register the consumer to receive loyalty points in any city or state along the route.

[0090] Once the central rewards mechanism **102** receives the enrollment data, the central rewards mechanism **102** then automatically processes that enrollment data as an enrollment application for the consumer to participate in the networked loyalty program of the invention (step **216**). The enrollment data may be communicated from the retailer system **104** (or the retailer regional processor **114**) to the central rewards mechanism **102** by any known routine or format, such as, for example batch processing or in real time. The central rewards mechanism then opens a consumer account, issues a consumer ID, and sends this and other relevant information about the loyalty program (e.g., general information about the loyalty program and the manner in which it operates, information regarding the possibility of opening an aggregate account and obtaining supplementary member IDs, terms and conditions of participation in the loyalty program, geographic-based earn and burn information, etc.) to the consumer (step **218**). At the point-of-sale, however, a temporary consumer account may be opened and/or a temporary consumer ID is issued to allow the consumer to participate in the loyalty program while the consumer is waiting to receive the consumer ID, account information (including (step **220**)). This temporary consumer account is eventually reconciled with the consumer account once it has been opened to credit the consumer with any rewards points or other benefits of participation in the loyalty program that may have accrued while the consumer was awaiting activation of the consumer account and receipt of the consumer ID.

[0091] This “instant”, one-step enrollment functionality simplifies enrollment in the system of the invention and saves consumers time by utilizing data that the retailer already has in its possession, thereby reducing the need for a consumer’s active participation in a separate enrollment process. Such a simplified enrollment process may lead to higher enrollment completion and participant acquisition rates as well as lower participant acquisition costs. Moreover, retailers may enjoy the benefits of consumer enrollment in the system of the invention without either requiring the dedication of substantial amounts of retailer space for enrollment purposes or decreasing checkout pull-through rates.

[0092] In an exemplary embodiment, as illustrated in FIG. 3, retailer terminal **108** comprises a retailer POS terminal **112**, such as a cash register for example. When a consumer ID or supplementary member ID is used at the time an item is

purchased, purchase data, including a SKU number, is input, sensed, or otherwise recognized by terminal **108**, and then the purchase data is processed and stored by retailer processor **110**. Retailer processor **110** comprises or is in communication with a suitable database **111** or other storage device for maintaining and storing purchase data and any other suitable retailer information. Database **111** may be any type of database, such as any of the database products described herein for example. Database **111** may be organized in any suitable manner, including as data tables or lookup tables. Purchase data that is stored in database **111** is available to the retailer's local back office system (not shown) for inventory, accounting, tax, data analysis, and other purposes. The captured purchase data may include the item purchased, the item's unit price, the number of items purchased, the date, the store location, an employee ID, geographic area information and any other information related to the purchase. In an exemplary embodiment, retailer processor **110** may also receive, process, and store manufacturer data, such as information regarding products and/or services, manufacturer geographic area information and UPC data, from manufacturers **106** who have enrolled in the system **100**. The manufacturer data may be stored in any suitable form, including data tables or lookup tables.

[0093] In accordance with the exemplary embodiments illustrated in FIG. 4, purchase data may also be transmitted to, and then stored and processed by, a retailer regional processor **114** (or, alternatively, a retailer national processor (not shown)) in communication with database **115** for the purpose of further back office and cumulative data analysis. Database **115** may be any type of database, such as any of the database products described in greater detail above for example. Database **115** may be organized in any suitable manner, including as data tables or lookup tables. In an exemplary embodiment, retailer processor **110** optionally may be integrated with retailer regional processor **114** (illustrated by the phantom lines encompassing Retailer Processor **1** and retailer regional processor **114** within the system of Retailer/Merchant #2), thereby forming a single device. In another embodiment, retailer processor **110** and retailer regional processor **114** are separate devices which may be either co-located with each other or remotely located from one another. For example, in one embodiment, retailer processor **110** and regional processor **114** are co-located at a particular retail store. In another embodiment, retailer processor **110** is located at a particular retail store and retailer regional processor **114** is remotely located at a regional office.

[0094] Regardless of the location of retailer regional processor **114**, retailer regional processor **114** receives and processes similar information from each of the retailer processors **110** associated with each of the retail stores owned by the same retailer. Whether the system **100** comprises a retailer regional processor **114** or a retailer national processor may be a function of the number of stores maintained by a particular retailer. That is, a larger retailer who has numerous stores throughout the country, for example, may choose to have a plurality of regional processors, while a smaller retailer with a few stores scattered across the country may be better served by a single, national processor. In exemplary embodiments, the retailer regional processors **114** and/or national processors communicate with a suitable database **115** or other storage device which is configured to store and maintain purchase data and any other suitable retailer information. In another exemplary embodiment, retailer regional processor **114** may

receive, process, and store manufacturer data, such as information regarding products and/or services, manufacturer geographic area information and UPC data, from manufacturers **106** who have enrolled in the system **100**. The manufacturer data may be stored in any suitable form, including data tables or lookup tables.

[0095] With momentary reference to FIG. 3, retailer terminal **108** may comprise a rewards terminal **116** through which a consumer may be updated with regard to various aspects of the system. For example, rewards terminal **116** may inform a consumer of the number of reward points in a certain geographic area that they have accumulated from all system participants and the types of awards that may be obtained using those reward points in a specific geographic area information. Moreover, rewards terminal **116** may suggest to the consumer various awards in certain geographic areas for which the consumer is eligible based upon the reward points generated by the consumer's network-wide purchases in certain geographic areas. In this context, network-wide purchases include any purchases of items corresponding to retailers and/or manufacturers participating in the system **100** in one or more geographic areas.

[0096] In an exemplary embodiment, rewards terminal **116** operates in real-time. In this context, "real-time" means that reward points are immediately, or nearly immediately, updated at the time purchases are made and are therefore immediately redeemable by the consumer at a point of sale in a geographic area. Thus, for example, a consumer may be informed by rewards terminal **116** at the point of sale that the item being purchased by the consumer may be purchased using the consumer's accumulated reward points in a geographic area, including points accumulated on a network level in the geographic area. Points accumulated on a network level enable consumers to accumulate points more rapidly than would be possible if only a single retailer or group of retailers were issuing the points in the same geographic area. In one embodiment, rewards terminal **116** may update a consumer's reward points in real-time and, in response to the consumer's particular points total, issue a coupon, a gift certificate, and/or additional bonus points to the consumer for use in a particular geographic area.

[0097] In another exemplary embodiment, the system may operate in batch mode, wherein points totals are calculated, stored, and periodically updated for access by the retailer terminal **108**, including POS terminal **112** and/or rewards terminal **116**. Thus, in this embodiment, the consumer may be notified of available points sometime after a purchase, or a suggestive sale in a geographic area may take place after a purchase. The total point count or suggestive sale may take into account points generated and accumulated as the result of network-wide purchases in a geographic area.

[0098] In various alternate embodiments of the invention, retailer terminal **108** may include a rewards terminal **116** but not a POS terminal **112**; a POS terminal **112** but not a rewards terminal **116**; or a POS terminal **112** in communication with a rewards terminal **116**. In alternate embodiments, where terminal **108** includes a POS terminal **112** and a rewards terminal **116**, the two terminals **112** and **116** may be variously implemented as separate terminals, integrated terminals, or software within a device. In another embodiment, where terminal **108** comprises a rewards terminal **116** but not a POS terminal **112**, terminal **108** may be a kiosk terminal located within a retail store or some other remote terminal which is capable of recognizing a consumer ID or supplementary

member ID and communicating with the system **100**. A consumer may use independent rewards terminal **116** to do, for example, any of the following: view accumulated reward points totals in a geographic area; view potential awards which the consumer may obtain in a geographic area in exchange for various numbers of points; select an award; redeem reward points for a selected award; request and/or receive a reward points advisory statement; and/or view a directory of participating retailers, manufacturers, and third-party providers in a geographic area.

[0099] In another exemplary embodiment, system **100** further comprises a consumer terminal **118**. Consumer terminal **118** is any remote terminal through which a consumer may access other aspects of the system **100**. Consumer terminal **118** may comprise any of the input devices, computing units, or computing systems described herein. Further, consumer terminal **118** communicates with the system **100** through any of the communications networks described herein. Consumer terminal **118** may also include, for example, a cellular phone caller location relative to cellular towers or global positioning system to automatically determine and communicate historical or current location information to the system. In one embodiment, consumer terminal **118** permits a consumer to engage multiple facets of the system **100** in an interactive online communications environment. The interactive online environment made available through consumer terminal **118** is an extension of the network-level incentive award program and is implemented in conjunction with other aspects of the system **100**. In this context, a consumer may use consumer terminal **118** for a variety of purposes. In one embodiment, consumer terminal **118** may be used to communicate with and receive information from the central rewards mechanism **102**. For example, a consumer may use consumer terminal **118** to do any of the following: communicate geographic area information; enroll in the system; enroll supplementary members in the system; identify particular individuals who are authorized to enroll as supplementary members in association with a primary member's aggregate consumer account; receive statements or reports regarding accumulated reward points totals; receive statements or reports regarding a supplementary member's accumulated reward points totals; receive bonus details; view potential awards which the consumer may obtain in exchange for various numbers of points in a geographic area; select an award in a geographic area; receive redemption information in a geographic area; view points adjustments; redeem reward points for a selected award in a geographic area; request and/or receive a reward points advisory statement; receive information regarding where and how points were earned and/or how points were redeemed in the respective geographic areas; receive information regarding expiration dates for points earned in a geographic area; receive information relating to any applicable fees; receive information regarding marketing promotions in a geographic area; and/or view a directory of participating retailers, manufacturers, and/or third-party providers in a geographic area.

[0100] In one embodiment, a consumer may use consumer terminal **118** to customize the online catalog for selective presentation to the consumer of particularly relevant rewards, rather than the entire rewards catalog. For example, a consumer may indicate an indicia of relevance (such as any aspect of the consumer's geographic area, demographics or profile, products related to or similar to previously purchased products, the consumer's total accumulated reward points, and the like), and the system then presents to the consumer

only those catalog items that are relevant to the consumer. The consumer may select the indicia of relevance by any means known and practiced in the art, such as by using a pointer in connection with a drop-down menu, a plurality of icons, or a plurality of "buttons" for example. This embodiment enables simplified navigation of the rewards catalog by consumers, thereby also enabling more expedient reward points redemption.

[0101] In accordance with a further aspect of the invention, customized bonus offerings may be communicated to the consumer through an online customized rewards catalog (as described herein), a customer service representative, email, or offline communications. In one embodiment, the consumer may use the consumer terminal **118** to receive bonus offerings that are customized according to any of the following consumer information: geographic area, demographics information, purchasing behavior, reward points earning behavior, and reward points redemption behavior.

[0102] In another embodiment, consumer terminal **118** may be used to interact with and/or make purchases and generate reward points from participating online retailers, as illustrated by the various phantom lines in FIG. 1. The online retailer may then communicate with the central rewards mechanism **102** to transmit and process a consumer ID or supplementary member ID, purchase data, etc., as described herein with reference to retailer **104** of FIG. 1. Information communicated between the online consumer, the online retailer, and the online central rewards mechanism may include, for example, geographic area information, product or service information, prices, availability of the product or service, shipping information, reward points information, available awards, information regarding points ratios and points redemption, and/or the like.

[0103] In one embodiment, consumer terminal **118** operates in real-time, as described herein with respect to rewards terminal **116**. In another embodiment, the consumer terminal **118** may operate in batch mode, as described herein. In still a further embodiment, consumer terminal **118** operates in a manner which includes aspects of both real-time functionality and batch mode functionality.

[0104] In accordance with a further aspect of the invention, the system **100** may comprise a rewards server **120** in communication with a database **121**, as illustrated in FIG. 3. Database **121** may be any type of database, such as any of the database products described herein for example. Database **121** may be organized in any suitable manner, including as data tables or lookup tables. In an exemplary embodiment, rewards server **120** may be any hardware and/or software that is configured to communicate with the central rewards mechanism **102** and either the retailer processor **110** or the retailer regional processor **114**. In alternate exemplary embodiments, rewards server **120** may be integrated with retailer system **104**; rewards server **120** may be integrated with central rewards mechanism **102**; or rewards server **120** may be separate from both retailer system **104** and central rewards mechanism **102**. In a further embodiment, the rewards server **120** may communicate with both a retailer national processor (not shown) and the central rewards mechanism **102**.

[0105] In an exemplary embodiment, rewards server **120** receives, processes, and stores geographic area information, manufacturer data and retailer data. Manufacturer data may include descriptions of products and/or services and UPC data transmitted from manufacturers **106** who have enrolled

in the system **100**. The manufacturer data may be stored in any suitable form, including data tables or lookup tables. Retailer data may include descriptions of products and/or services and SKU data transmitted from retailers **104** who have enrolled in the system **100**. The retailer data may be stored in any suitable form, including data tables or lookup tables.

[0106] In an exemplary embodiment, the rewards server **120** performs a plurality of functions that might otherwise be performed by the central rewards mechanism **102**. For example, since rewards calculations require significant processing and memory resources, performance of calculations processing by the rewards server **120** at the regional level lessens the processing load on the central rewards mechanism **102**, thereby increasing the efficiency of the central rewards mechanism **102**. In an exemplary embodiment, each retailer's region, which comprises a plurality of that retailer's stores or outlets, accesses a rewards server **120** which acts as an intermediary between the retailer regional processor **114** and the central rewards mechanism **102**. This configuration relieves the processing, power, memory, and other requirements of the central rewards mechanism **102**. Moreover, each retailer is but one of many retailers that may participate in the network level rewards structure. Accordingly, a plurality of rewards servers **120** may be in communication with the central rewards mechanism **102** as well as each of the participating retailer regional processors **114**, further alleviating the processing burden and freeing up the resources of the central rewards mechanism **102**.

[0107] Implementations which include at least one independent rewards server **120** are also advantageous because cost-effective communications links may be used to facilitate communications with the central rewards mechanism **102**. Performance by the rewards server **120** of many of the "intelligence functions" of the system **100** permits transmission of only particular forms of purchaser information to the central rewards mechanism **102**. In an exemplary embodiment, data sent from the rewards server **120** to the central rewards mechanism **102** may include the geographic area information, consumer ID or supplementary member ID and the total number of reward points earned by a consumer in a particular transaction. In another exemplary embodiment, data transmitted by the rewards server **120** to the central rewards mechanism **102** may also include any pre-selected aspect of the consumer profile or supplementary member profile, any pre-selected aspect of the purchase data, and/or any other pre-selected data associated with a consumer, a retailer, a manufacturer, and/or a third-party provider in a geographic area. Pre-selection of the types of data transmitted by the rewards server **120** to the central rewards mechanism **102** may be conducted by the system administrator, a retailer, a manufacturer, and/or a third-party provider. Thus, data which may be useful for purposes of data analysis but unrelated to the rewards feature, such as the characteristics of the particular item purchased for example, may not need to be transmitted to the central rewards mechanism **102**.

[0108] Exemplary functions performed by the rewards server **120** may include the association of geographic area information, UPC and SKU data; manipulation of the rewards criteria applicable in particular geographic areas, which may further depend upon the retailer, manufacturer, and/or third-party provider involved in a specific transaction with a consumer; calculation of rewards benefits earned by the consumer in a geographic area; filtration functions for

determining which data is transmitted from the rewards server **120** to the central rewards mechanism **102**; and/or various types of data analyses, as described herein. In an exemplary embodiment, the retailer system **104** houses, maintains, and updates the hardware and/or software of the rewards server **120**. In another embodiment, rewards server **120** may be housed, maintained, and updated by the system administrator.

[0109] In accordance with another embodiment of the present invention, the system **100** permits an open payment system. Since the invention generally provides that consumer participation in the system is based upon a consumer ID or supplementary member ID, a purchaser may use any of multiple payment vehicles (such as cash, check, charge card, credit card, debit card, MasterCard®, Visa®, and/or the American Express® Card for example) to make purchases at the various retailers and still participate in the system. Thus, in one embodiment, geographic area information, the consumer ID or supplementary member ID is independent of any particular payment vehicle, such as a credit card for example.

[0110] However, alternate embodiments of the invention may be implemented which associate a geographic area, consumer ID or supplementary member ID with a particular payment vehicle, such as a consumer's credit card account, charge card account, debit card account, and/or bank account for example. In this embodiment, the retailer conducting the transaction need only participate in the system to the extent that the retailer provides its geographic area or SKU data to the system **100**, such as to the rewards server **120**. In other words, when a geographic area, consumer ID or supplementary member ID is associated with an instrument (e.g., a credit card) from a third-party provider, the retailer need not provide a rewards terminal or other terminal capable of processing the consumer ID or supplementary member ID, since the third-party provider may process the consumer ID or supplementary member ID as part of the payment transaction. Thus, in this embodiment, rewards benefits may be earned by the consumer on a network-wide level in a geographic area without the retailer's direct participation in the rewards feature (notwithstanding the retailer's participation in transmitting SKU data to the system). Moreover, it will be appreciated that a single geographic area, consumer ID or supplementary member ID may be associated with multiple third-party payment vehicles, thereby allowing a consumer to generate reward points regardless of the particular payment vehicle selected for a particular purchase.

[0111] With reference to FIG. 5, an exemplary central rewards mechanism **502** includes a central processor **504** in communication with other elements of the rewards mechanism **502** through a system interface or bus **506**. A suitable display device/input device **508**, such as a keyboard or pointing device in combination with a monitor, may be provided for receiving data from and outputting data to a user of the system. A memory **510** associated with the rewards mechanism **502** includes various software modules, such as an enrollment module **512** and an authentication module **514** for example. The memory **510** preferably further includes an operating system **516** which enables execution by processor **504** of the various software applications residing at enrollment module **512** and authentication module **514**. Operating system **516** may be any suitable operating system, as described herein. In one embodiment, a network interface **518** is provided for suitably interfacing with other elements of

the incentive awards system, such as the elements described herein with reference to FIGS. 1, 3, and 4.

[0112] Lastly, a storage device 520, such as a hard disk drive for example, preferably contains files or records which are accessed by the various software modules, such as enrollment module 512 and authentication module 514. In particular, consumer data 522 comprises information received from a consumer upon registration with the rewards mechanism 502, including any information corresponding to geographic area or supplementary members that may be affiliated with a primary member's aggregate consumer account. Consumer rewards 524 comprises data corresponding to each consumer's rewards account, including data corresponding to any aggregate consumer account and any supplementary members that may be affiliated with a primary member and/or an aggregate consumer account. Consumer rewards 524 may include cumulative reward points totals in a geographic area as well as historical totals and rewards account activity over time in a geographic area. In one embodiment, consumer rewards 524 includes cumulative reward points totals, historical totals, and rewards account activity for supplementary members affiliated with an aggregate consumer account. Retailer records 526 comprises information received from the various participating retailers in a geographic area. Manufacturer records 528 comprises information received from the various participating manufacturers in a geographic area. One skilled in the art will appreciate that the storage device 520 and, therefore, geographic area information, consumer data 522, consumer rewards 524, retailer records 526, and manufacturer records 528 may be co-located with the rewards mechanism 502 or may be remotely located with respect to the rewards mechanism 502. If the storage device 520 is remotely located with respect to the rewards mechanism 502, communication between storage device 520 and rewards mechanism 502 may be accomplished by any suitable communication link but is, in one embodiment, accomplished through a private intranet or extranet.

[0113] Enrollment module 512 receives information from consumers, retailers, and/or manufacturers who wish to participate in the system. Enrollment module 512 accesses and stores information in storage device 520. In one embodiment, enrollment module 512 receives, stores, and accesses data corresponding to geographic area, primary members and their affiliated supplementary members. In another embodiment, enrollment module 512 processes enrollment data received from a retailer system (e.g., retailer system 104, retailer regional processor 114, or a national retailer processor) to facilitate instant enrollment of a consumer at a point of sale, as described herein with reference to FIG. 2. Processing of enrollment data by enrollment module 512 may include, for example, associating geographic area information, opening a consumer account, issuing a consumer ID, and/or reconciling data in a temporary consumer account with a newly opened consumer account.

[0114] Authentication and/or validation of the identity and status of participants, including any of the other system components, may be performed by the authentication module 514, which may have access to the records residing in storage device 520. In one embodiment, authentication module 514 authenticates and/or validates the geographic area, identity, status, and/or affiliation of supplementary members participating in the system. The validation may occur by cross-checking geographic area information such as, for example, zip code with phone number or zip code with street address.

[0115] With reference to FIG. 6, an exemplary rewards server 602 includes a central processor 604 in communication with other elements of the rewards server 602 through a system interface or bus 606. A suitable display device/input device 608, such as a keyboard or pointing device in combination with a monitor, may be provided for receiving data from and outputting data to a user of the system. A memory 610, which is associated with the rewards server 602, includes a variety of software modules, such as an association module 612, a rewards calculation module 614, a data analysis module 616, and a filtering module 618 for example. The memory 610 preferably further includes an operating system 620 which enables execution by central processor 604 of the various software applications residing at the various modules 612, 614, 616, and 618. Operating system 620 may be any suitable operating system, as described herein. In one embodiment, a network interface 622 is provided for suitably interfacing with other elements of the incentive awards system, such as the elements described herein with reference to FIGS. 1, 3, and 4.

[0116] Storage device 624, such as a database as described herein for example, includes files or records which are accessed by the various software modules 612, 614, 616, and 618. In particular, manufacturer data 626 comprises information received from a manufacturer, such as geographic area information, descriptions or other information regarding the manufacturer's products and/or services as well as UPC data for example. Retailer data 628 comprises information received from a retailer, such as geographic area information, descriptions or other information regarding the retailer's products and/or services as well as SKU data for example. Consumer data 630 comprises information pertaining to a consumer, including a geographic area information, consumer ID or supplementary member ID, purchase data, a consumer profile or supplementary member profile, and/or the like. One skilled in the art will appreciate that the storage device 624 and, therefore, manufacturer data 626, retailer data 628, and consumer data 630 may be co-located with the rewards server 602 or may be remotely located with respect to the rewards server 602. If the storage device 624 is remotely located with respect to the rewards server 602, communication between storage device 624 and rewards server 602 may be accomplished by any suitable communication link but is preferably accomplished through a private intranet or extranet.

[0117] Referring next to FIGS. 7 and 8, the process flows depicted in these figures are merely exemplary embodiments of the invention and are not intended to limit the scope of the invention as described herein. It will be appreciated that the following description makes appropriate reference not only to the steps depicted in FIGS. 7 and 8 but also to the various system components as described herein with reference to FIGS. 1, 3, and 4.

[0118] FIG. 7 is flowchart illustrating an exemplary process for capturing and processing geographic information and POS SKU data in accordance with the present invention. The association or matching of geographic area information, UPC and SKU data begins with POS data capture (step 702). When a consumer presents a consumer ID or supplementary member ID to a retailer 104 at the time of purchasing an item from the retailer 104, the consumer ID or supplementary member ID is processed by a rewards terminal 116 that recognizes the consumer ID or supplementary member ID, determines appropriate geographic area information and identifies the

consumer as a participant in the system **100**. Purchase data is captured by the retailer POS terminal **112**. Purchase data may include any of the data types noted above. For example, purchase data may include any of the following: a SKU number; a unit price; a total transaction price; the payment vehicle (s) used; a store ID which identifies the particular store location in a geographic area if a retailer operates more than one store; a department ID, if the store has multiple departments; the date of the transaction; the time of the transaction; the employee ID of the store clerk who facilitates the transaction; a POS terminal ID to identify the particular terminal conducting the transaction; any retailer-specific incentive program ID; and/or the like. The retailer POS terminal **112** creates a transaction file comprising the geographic area information, consumer data (including a consumer ID or supplementary member ID) and purchase data (including a SKU number associated with each item purchased), and the transaction file is then stored by the retailer processor **110** in database **111** (step **704**).

[**0119**] The various transaction files may be consolidated by the retailer processor **110** and then forwarded to the retailer regional processor **114** (step **706**) for further back-office and cumulative data analysis performed by retailer **104**.

[**0120**] In an exemplary embodiment, the transaction file is transmitted by either of the retailer processor **110** or the retailer regional processor **114** to the rewards server **120** (step **708**). The geographic area information and SKU information for each item included in the transaction file is then matched to or associated with corresponding UPC information which identifies the related manufacturer **106**. An exemplary association process is illustrated in the flowchart of FIG. **8**. Association of geographic area information, SKU and UPC data may be accomplished through any data association technique known and practiced in the art. For example, the association may be accomplished either manually or automatically. Automatic association techniques may include, for example, a database search, a database merge, GREP, AGREP, SQL, and/or the like.

[**0121**] In one embodiment, the system is thereby enabled to track the purchasing behaviors of supplementary members in certain geographic areas as well as primary members.

[**0122**] In an exemplary embodiment, the rewards server **120** utilizes the association information to calculate the reward points in a geographic area generated by a consumer's purchase. For example, an appropriate series of pointers leading from geographic area information to a SKU to a UPC to a manufacturer ID may ultimately direct the rewards server **120** to employ a 2-for-1 manufacturer rewards ratio to award a consumer twice as many points as the dollar amount of the consumer's total transaction price. In another exemplary embodiment, an appropriate series of pointers may result in the calculation of reward points based upon multiple rewards criteria, such as rewards criteria associated with the manufacturer of the item as well as rewards criteria associated with a third-party provider in a certain geographic area for example.

[**0123**] With momentary reference to FIG. **7**, in one exemplary embodiment, the geographic area information, consumer ID or supplementary member ID and the earned rewards information are transmitted to the central rewards mechanism **102** after the rewards server **120** has filtered out consumer data associated with the consumer ID or supplementary member ID (step **710**). In another embodiment, the central rewards mechanism **102** may use the captured and

matched geographic area information and UPC information to determine rewards and/or for data analysis.

[**0124**] In accordance with another aspect of the invention, FIG. **9** is a diagram illustrating an exemplary profiling system **900**. Profiling system **900** may be used to generate and analyze purchaser profiles. In one embodiment, the purchaser profiles may be used to effectively market products and services to consumers. For example, the profiling system **900** permits the cross-selling of goods and services in a manner that was previously thought to be impractical, if not impossible. That is, the comprehensive nature of the data made available through profiling system **900** permits network-wide, product-level knowledge of a consumer's specific purchasing patterns across retailers in certain geographic areas. This knowledge may be used to develop targeted marketing strategies which can enhance relationships between and among manufacturers, retailers, and consumers.

[**0125**] For instance, if a consumer purchases both Product 1 (e.g., a digital video disc) and Product 2 (e.g., a compact disc) in a geographic area in a given month, and if the consumer makes these purchases using a consumer ID, then profiling system **900** maintains a record of both these purchases related to the geographic area, regardless of whether the products were purchased from different retailers. Appropriate analytics on the data stored by profiling system **900** may then be used to determine that this consumer may be a candidate for purchasing similar or related products or services in a geographic area (e.g., a surround sound audio system in the case of the examples above). The heightened awareness provided by profiling system **900** of a consumer's particular situation permits the use of targeted marketing efforts that present the consumer with specialized offers or other promotions that are likely to elicit additional purchases by that consumer. Not only does this benefit manufacturers and retailers, but the consumer is benefited by being made aware of promotional offers and/or discounts on products and services that are in fact relevant to the consumer.

[**0126**] In the exemplary embodiment illustrated in FIG. **9**, profiling system **900** comprises a central rewards mechanism **902**, a retailer/merchant system **904**, a profiler **906**, a profiler interface **922**, and an end-user **924**. It will be appreciated that the system **900** may comprise any number of retailer systems **904** and any number of end-users **924**. Moreover, it will be appreciated that central rewards mechanism **902** (and/or any of its sub-components) and profiler **906** may be separate components or may be integrated to form a single component. It will also be appreciated that profiler **906** and profiler interface **922** may be separate components or may be integrated to form a single component.

[**0127**] The central rewards mechanism **902** is substantially similar to, and may comprise any of the components of, central rewards mechanism **102** and/or central rewards mechanism **502**, as described herein with reference to FIGS. **1**, **3**, **4**, and **5**. Moreover, central rewards mechanism **902** may be configured to include any of the functionality described herein with reference to central rewards mechanism **102** and/or central rewards mechanism **502**. In particular, central rewards mechanism **902** comprises an enrollment module **912**, which is substantially similar to enrollment module **512** of FIG. **5**, and a storage device **920**, which is substantially similar to storage device **520** of FIG. **5**. In one embodiment, enrollment module **912** receives consumer enrollment data

from consumers and then processes and transmits the consumer enrollment data to storage device 920 for storage and future retrieval.

[0128] In an exemplary embodiment, the retailer system 904 comprises a retailer terminal 908 and a retailer processor 910. The retailer processor 910 may be in communication with a database 911. The retailer system 904 is substantially similar to, and may comprise any of the components of, retailer system 104, as described herein with reference to FIGS. 1, 3, and 4. Moreover, retailer system 904 may be configured to include any of the functionality described herein with reference to retailer system 104. Retailer terminal 908 is substantially similar to, and may comprise any of the components and/or functionality of, retailer terminal 108; retailer processor 910 is substantially similar to, and may comprise any of the components and/or functionality of, retailer processor 110; and database 911 is substantially similar to, and may comprise any of the components and/or functionality of, database 111.

[0129] As described in detail above with reference to retailer terminal 108, the retailer terminal 908 records consumer purchases in a geographic area, either online (such as at a merchant web site for example) or offline (such as at a retailer store for example), and then transmits the purchase data to retailer processor 910. Retailer processor 910 processes and suitably stores the purchase data. Retailer processor 910 is in communication with a suitable database 911 or other storage device for maintaining and storing purchase data and/or any other suitable retailer information.

[0130] In one embodiment, profiler 906 comprises a data conditioner 914, a data analytics module 916, and a detail database 918. As illustrated in FIG. 10, an exemplary profiler 906 further includes a processor 926 in communication with other elements of profiler 906 through an interface or bus 928. A suitable display/input device 930, such as a keyboard or pointing device in combination with a monitor, may be provided for receiving data from and outputting data to a user of profiler 906. A memory 932 associated with profiler 906 includes a data conditioner 914 and an analytics module 916. Memory 932 preferably further includes an operating system 934 which enables execution by processor 926 of the software applications residing at data conditioner 914 and analytics module 916. Operating system 934 may be any suitable operating system, as described herein. The detail database 918 may be any type of database, such as relational, hierarchical, object-oriented, and/or the like. Common database products that may be used to implement database 918 include DB2 by IBM (White Plains, N.Y.), any of the database products available from Oracle Corporation (Redwood Shores, Calif.), any of the database products available from Sybase, Inc. (Emeryville, Calif.), Microsoft Access by Microsoft Corporation (Redmond, Wash.), or any other database product. In one embodiment, a network interface 936 is provided for interfacing the profiler 906 with other elements of the profiling system 900, described herein with reference to FIG. 9.

[0131] With reference once again to FIG. 9, profiling system 900 further includes a profiler interface 922 and an end-user 924. Profiler interface 922 may comprise any device or system that permits access to data that is maintained and/or generated by profiler 906. In one embodiment, profiler interface 922 permits an end-user 924 to access profiler 906 and retrieve data maintained or generated by profiler 906. End-user 924 may include any person, entity, charitable organization, machine, software, hardware, and/or the like that may

seek access to data that is maintained and/or generated by profiler 906. In one embodiment, end-user 924 may be any of a retailer, a manufacturer, a consumer, or a third-party provider. In another embodiment, the end-user 924 may be the system administrator.

[0132] Communication between an end-user 924 and profiler interface 922 may be accomplished through any suitable communication means, such as any of the means described in detail above, for example. In an exemplary embodiment, profiler interface 922 is a web interface which comprises a web server that enables an end-user 924 to communicate with profiler interface 922 via a suitable communications link, such as the Internet, for example, to access data residing at profiler 906. In another embodiment, profiler interface 922 includes an authentication module (not shown) which authenticates and/or validates the identity and status of end-users 924 who seek access to profiler 906. The authentication module may have access to a suitable storage device, such as a database for example, which maintains records identifying authorized end-users 924.

[0133] As will be described in greater detail herein, profiling system 900 may optionally include a rewards server 938 (illustrated in FIG. 9 by phantom lines which represent that it is optional). The rewards server 938 is substantially similar to, and may comprise any of the components and/or functionality of, rewards server 120 and/or 602, as described herein with reference to FIGS. 3, 4, and 6. If used, rewards server 938 receives a transaction file (i.e., purchase data (including a retailer item identifier, such as a SKU for example) resulting from a consumer transaction) from the retailer system 904 and standardizes the transaction file by associating the retailer item identifier with a corresponding manufacturer item identifier (e.g., a UPC). By translating or converting SKU data into corresponding UPC data, the goods and/or services that are part of each consumer transaction are characterized in a uniform manner that facilitates data analysis, regardless of the number of participating retailers. It will be appreciated that, if used, the rewards server 938 may be a separate component from profiler 906 or may be integrated with profiler 906.

[0134] In another embodiment of profiling system 900, profiler 906 may optionally comprise a warranty module 940 (illustrated in FIG. 9 by phantom lines which represent that it is optional). In this embodiment, the warranty module may be used to search detail database 918 for purchase data relating to manufacturers' warranties in a geographic area. In one embodiment, a consumer who has purchased a product that has a manufacturer's warranty may be informed by profiler 906, via profiler interface 922 and a suitable communications link (such as through email over the Internet for example), of any available opportunities to purchase an extended warranty plan in a geographic area. In another embodiment, a consumer may be informed by profiler 906 of any available opportunities to purchase an extended warranty plan for a product in a geographic area whose manufacturer's warranty is about to expire.

[0135] Referring next to FIGS. 11 and 12, the process flows depicted in these figures are exemplary embodiments of the invention and are not intended to limit the scope of the invention as described herein. It will be appreciated that the following description makes appropriate reference not only to the steps depicted in FIGS. 11 and 12 but also to the various system components as described herein with reference to FIGS. 9 and 10.

[0136] FIG. 11 is flowchart illustrating an exemplary process for generating a purchaser profile for a consumer or a group of consumers. Generating a purchaser profile begins with enrolling a consumer in the system of the invention (step 1102). As described herein, enrollment is accomplished by central rewards mechanism 902. That is, enrollment module 912 receives and processes the consumer enrollment data, facilitates issuance of a consumer ID to the consumer, and transmits the consumer enrollment data to storage device 920. In this context, the term “consumer ID” shall be understood to include “supplementary member ID”. After a consumer is enrolled in the system, the consumer may use the consumer ID during a transaction with a retailer system 904.

[0137] When a consumer uses a consumer ID, the consumer ID and geographic area information, together with the purchase data associated with the retailer transaction in a geographic area, is captured at the point-of-sale (step 1104). That is, when a consumer presents a consumer ID to a retailer 904 at the time of purchasing an item from the retailer 904, the consumer ID and geographic area information is processed by a rewards terminal 908 that recognizes the consumer ID and identifies the consumer as a participant in the system 900 in a geographic area. Purchase data is then captured by the retailer terminal 908. Purchase data may include any of the data types noted herein. For example, purchase data may include any of the following: geographic area information, a SKU number; a unit price; a total transaction price; the payment vehicle(s) used; a store ID which identifies the particular store location if a retailer operates more than one store; a department ID, if the store has multiple departments; the date of the transaction; the time of the transaction; the employee ID of the store clerk who facilitates the transaction; a retailer terminal ID to identify the particular terminal conducting the transaction; any retailer-specific incentive program ID; any product warranty that may apply, as well as the terms of the warranty; and/or the like. The retailer terminal 908 creates and processes a transaction file comprising consumer-identifying data (i.e., the consumer ID) and purchase data (including a SKU number associated with each item purchased) (step 1106). The transaction file may then be stored by the retailer processor 910 in database 911.

[0138] Optionally, the transaction file may be transmitted by the retailer system 904 to the rewards server 938 (step 1108). (Steps 1108 through 1114 are illustrated in phantom lines in FIG. 11 to represent that these steps are optional.) In this embodiment, the transaction file is standardized by matching or associating the SKU information for each item included in the transaction file with corresponding UPC information which identifies the manufacturer of the item and/or a general description of the goods or services (step 1110). Association of SKU and UPC data may be accomplished through any data association technique known and practiced in the art. For example, the association may be accomplished either manually or automatically. Automatic association techniques may include, for example, a database search, a database merge, GREP, AGREP, SQL, and/or the like. An exemplary method for associating SKU and UPC data is described herein with reference to FIG. 8. In this embodiment, after the rewards server 938 associates the SKU and UPC data, the rewards server 938 modifies or standardizes that transaction file by including the UPC data (step 1112) and then transmits the standardized transaction file to

the profiler 906 (step 1114). In one embodiment, the rewards server 938 transmits the standardized transaction file to the data conditioner 914.

[0139] In an alternate embodiment, the transaction file is transmitted by the retailer system 904 to the profiler 906 (step 1116). In one embodiment, the transaction file is transmitted by retailer system 904 to the data conditioner 914. In this embodiment, after data conditioner 914 has received the transaction file, data conditioner 914 standardizes the transaction file (step 1118). Since a given retailer will identify a product/service by an SKU that is relevant only to that retailer, it is useful to identify and characterize products and services in a uniform manner across retailers. Such standardization facilitates data analysis across retailers, permits increased sophistication in the types of analyses that may be performed, and/or enhances the richness of the information derived from such analyses.

[0140] In one embodiment, data conditioner 914 standardizes the transaction file by associating geographic area information, SKU and UPC data in a manner similar to that described herein with reference to rewards server 938.

[0141] In another embodiment, as illustrated in FIG. 12, the data conditioner 914 standardizes the transaction file by deriving a standard identifier from a SKU lookup table which is stored in a suitable database, such as detail database 918 for example. In an exemplary embodiment, the SKU lookup table is created when detail database 918 receives and stores retailer data, such as SKU and related product or service data, for example, transmitted to the detail database 918 by retailer system 904 (step 1202). In an exemplary implementation, detail database 918 stores retailer data in a separate retailer data table for each participating retailer system 904. Each retailer data table may comprise a plurality of fields, such as “geographic information”, “SKU” and “product description”, for example, and a plurality of records, each record corresponding to an item offered by a participating retailer 904. For each record stored in the retailer data table, detail database 918 then generates, assigns, and stores as part of the record a standard identifier (step 1204). The standard identifier uniquely identifies an item stored in the data table and is linked to the SKU and/or geographic area information that is also associated with that item (step 1206). The standard identifier may be any suitable identifier, such as a number, a code, an alphanumeric identifier, etc., that may be used to uniquely designate or identify an item in the SKU lookup table. In an exemplary embodiment, the “geographic area information”, “SKU” and “standard identifier” fields in the SKU data table may be linked by an appropriate pointer.

[0142] The SKU lookup table is then used by data conditioner 914 to derive a standard identifier that corresponds to the specific product or service represented by the particular retailer” SKU number in the transaction file. Thus, when the data conditioner 914 receives the transaction file, the data conditioner 914 searches the SKU lookup table for the appropriate SKU number. That is, when the data conditioner 914 searches the SKU lookup table and locates the particular SKU that has been captured and transmitted by the retailer system 904, the specifically identified SKU data field uses a pointer to direct the data conditioner 914 to the standard identifier data field that corresponds to that SKU number (step 1208). After data conditioner 914 derives a standard identifier for each item included in the transaction file, the standard identifier is then linked to, or stored as a part of, the transaction file (step 1210).

[0143] As mentioned previously, while the SKU is an identifier that is defined by a particular retailer in a geographic area and has little meaning outside the retailer system 904, the standard identifier is used to characterize a particular product or service in a geographic area across multiple retailers. For example, if SKU 1 is used by Retailer 1 to identify Product A, and if SKU 2 is used by Retailer 2 to identify Product A, Product A is identified by a single Standard Identifier by profiler 906, regardless of the retailer system 904 from which the transaction file containing data on Product A originated. The SKU lookup table may be maintained by the system administrator and updated periodically with information received from the retailer systems 904.

[0144] In another embodiment, the retailer system 904 standardizes the transaction file prior to transmitting the transaction file to the profiler 906. In one embodiment, retailer system 904 standardizes the transaction file by associating geographic area information, SKU and UPC data, as described herein with reference to rewards server 938. In another embodiment, retailer system 904 standardizes the transaction file by using a SKU lookup table, as described herein with reference to FIG. 12. After standardizing the transaction file, the retailer system 904 transmits the standardized transaction file to profiler 906. Whether transmitted to reward server 938 or profiler 906, a transaction file, whether or not it has been standardized prior to transmission, may be transmitted from retailer system 904 either as part of a periodic batch process or in real time as each transaction occurs.

[0145] Referring once again to FIG. 11, after the transaction file has been standardized, either by rewards server 938 or data conditioner 914, detail database 918 receives the standardized transaction file and queries whether the consumer associated with the transaction file already has an established record in the detail database 918 (step 1120). If the consumer associated with the transaction file already has an established record in detail database 918, as determined by a search of detail database 918 by data conditioner 914 for the consumer ID contained in the transaction file, then data conditioner 914 writes the newly obtained transaction file to the established record in detail database 918 (step 1122), thereby updating the consumer's record to reflect the additional purchases. This updated record may then be used by analytics module 916 to generate a purchaser profile, as described in greater detail below (step 1130).

[0146] If the consumer associated with the transaction file does not have an established record in detail database 918, as determined by data conditioner 914 based upon a search of detail database 918, then data conditioner 914 creates a new record in detail database 918 for the standardized transaction file (step 1124). The data conditioner 914 then merges consumer enrollment data stored by central rewards mechanism 902 with the standardized transaction file. That is, for each standardized transaction file that is written to detail database 918 as a new record, data conditioner 914 requests and receives consumer enrollment data from central rewards mechanism 902 (step 1126). The request identifies the consumer ID associated with the transaction file and asks that consumer enrollment data associated with the consumer ID be transmitted from the central rewards mechanism 902 to data conditioner 914. The central rewards mechanism 902 retrieves the appropriate consumer enrollment data file from storage device 920 and then transmits the consumer enrollment data to data conditioner 914. Data conditioner 914 then

merges the consumer enrollment data with the standardized transaction file contained in the newly created record in detail database 918 (step 1128).

[0147] The standardized transaction file and the consumer enrollment data may be merged by any suitable database merge function, such as by using a "key field" (as described herein) within each of the records stored in storage device 920 and detail database 918. In one embodiment, the standardized transaction file and the consumer enrollment data are merged using a key field which corresponds to a consumer ID data field.

[0148] Analytics module 916 generates purchaser profiles by accessing and using the data in detail database 918 (step 1130). As will be appreciated, any known methods for performing data analysis, analytics, econometrics, modeling, data mining, marketing analyses, etc., may make use of the combined consumer enrollment data and purchase data stored in detail database 918. Analytics module 916 may generate purchaser profiles in the form of reports, summary data sheets, spread sheets, graphical output, combinations of these, and/or the like. The purchaser profiles may be stored by detail database 918, viewed on a display screen (e.g., display device 930), printed, transmitted to an end-user 924, and/or the like.

[0149] An end-user 924 can access profiler 906 through profiler interface 922. In one embodiment, an end-user 924 may be enabled to use profiler interface 922 to accomplish one or more of the following which may be further divided or grouped by geographic area information: (1) use analytics module 916 to run analytics on any of (or selected parts of) the data stored in detail database 918; (2) use analytics module 916 to run analytics on summary data that is stored in detail database 918; (3) access detail database 918, download particular data to the end-user's system, and run specific end-user analytics (i.e., analytics which reside at end-user 924) to generate custom purchaser profiles based upon an end-user's particular requirements; and/or (4) access reports, summary data sheets, spread sheets, graphical output, combinations of these, and/or the like that are generated by analytics module 916 and stored by detail database 918.

[0150] It will be appreciated that the system 900 may be adapted to implement a suitable privacy policy which protects the personal information of participating consumers. That is, the system 900 may limit access to the data, or portions of the data, in a purchaser profile that is made available to end-users 924 by profiler 906, depending upon the identity of end-user 924 and/or the wishes of a particular consumer. For example, the system 900 may, prior to enrolling a consumer, give the consumer appropriate notification regarding any and all potential disclosures of consumer enrollment data and/or purchase data and/or data residing in a purchaser profile that has been generated by the system. Moreover, the system may permit the consumer to identify the types of data that the consumer does not authorize the system to disclose to end-users 924 and/or to identify the types of end-users 924 whom the consumer does not wish to grant access to data regarding that consumer.

[0151] The detailed description of exemplary embodiments of the invention herein makes reference to the accompanying drawings and pictures, which show the exemplary embodiment by way of illustration and its best mode. While these exemplary embodiments are described in sufficient detail to enable those skilled in the art to practice the invention, it should be understood that other embodiments may be real-

ized and that logical and mechanical changes may be made without departing from the spirit and scope of the invention. Thus, the detailed description herein is presented for purposes of illustration only and not of limitation. For example, the steps recited in any of the method or process descriptions may be executed in any order and are not limited to the order presented.

[0152] For the sake of brevity, conventional data networking, application development and other functional aspects of the systems (and components of the individual operating components of the systems) may not be described in detail herein. Furthermore, the connecting lines shown in the various figures contained herein are intended to represent exemplary functional relationships and/or physical couplings between the various elements. It should be noted that many alternative or additional functional relationships or physical connections may be present in a practical electronic transaction system.

[0153] The various system components discussed herein may include one or more of the following: a host server or other computing systems including a processor for processing digital data; a memory coupled to said processor for storing digital data; an input digitizer coupled to the processor for inputting digital data; an application program stored in said memory and accessible by said processor for directing processing of digital data by said processor; a display device coupled to the processor and memory for displaying information derived from digital data processed by said processor; and a plurality of databases. Various databases used herein may include: client data; merchant data; financial institution data; and/or like data useful in the operation of the present invention. As those skilled in the art will appreciate, user computer may include an operating system (e.g., Windows NT, 95/98/2000, Linux, Solaris, etc.) as well as various conventional support software and drivers typically associated with computers. User computer can be in a home or business environment with access to a network. In an exemplary embodiment, access is through the Internet through a commercially-available web-browser software package.

[0154] Communication among the parties in accordance with the present invention may be accomplished through any suitable communication protocols, such as, for example, a telephone network, Intranet, Internet, point of interaction device (point of sale device, personal digital assistant, cellular phone, kiosk, etc.), online communications, off-line communications, wireless communications, transponder communications, local area network (LAN), wide area network (WAN), networked or linked devices and/or the like. One skilled in the art will also appreciate that, for security reasons, any databases, systems, devices, servers or other components of the present invention may consist of any combination thereof at a single location or at multiple locations, wherein each database or system includes any of various suitable security features, such as firewalls, access codes, encryption, decryption, compression, decompression, and/or the like.

[0155] Any databases discussed herein may be any type of database, such as relational, hierarchical, graphical, object-oriented, and/or other database configurations. Common database products that may be used to implement the databases include DB2 by IBM (White Plains, N.Y.), various database products available from Oracle Corporation (Redwood Shores, Calif., Microsoft Access or MSSQL by Microsoft Corporation (Redmond, Wash.), or any other suitable database product. Moreover, the databases may be orga-

nized in any suitable manner, for example, as data tables or lookup tables. Each record may be a single file, a series of files, a linked series of data fields or any other data structure. Association of certain data may be accomplished through any desired data association technique such as those known or practiced in the art. For example, the association may be accomplished either manually or automatically. Automatic association techniques may include, for example, a database search, a database merge, GREP, AGREP, SQL, and/or the like. The association step may be accomplished by a database merge function, for example, using a "key field" in preselected databases or data sectors.

[0156] More particularly, a "key field" partitions the database according to the high-level class of objects defined by the key field. For example, certain types of data may be designated as a key field in a plurality of related data tables and the data tables may then be merged on the basis of the type of data in the key field. In this regard, the data corresponding to the key field in each of the merged data tables is preferably the same or of the same type. However, data tables having similar, though not identical, data in the key fields may also be merged by using AGREP, for example.

[0157] The computers discussed herein may provide a suitable website or other Internet-based graphical user interface which is accessible by participants. In one embodiment, the Internet Information Server, Microsoft Transaction Server, and Microsoft SQL Server, are used in conjunction with the Microsoft operating system, Microsoft NT web server software, a Microsoft SQL database system, and a Microsoft Commerce Server. Additionally, components such as Access or SQL Server, Oracle, Sybase, Informix MySQL, Interbase, etc., may be used to provide an ADO-compliant database management system.

[0158] The term "webpage" as it is used herein is not meant to limit the type of documents and applications that might be used to interact with the user. For example, a typical website might include, in addition to standard HTML documents, various forms, Java applets, Javascript, active server pages (ASP), common gateway interface scripts (CGI), extensible markup language (XML), dynamic HTML, cascading style sheets (CSS), helper applications, plug-ins, and the like. A server may include a webservice which receives a request from a browser which includes a URL (<http://yahoo.com/stockquotes/ge>) and an IP address (123.56.789). The webservice retrieves the appropriate webpages and sends the webpages to the IP address.

[0159] The present invention may be described herein in terms of functional block components, screen shots, optional selections and various processing steps. It should be appreciated that such functional blocks may be realized by any number of hardware and/or software components configured to perform the specified functions. For example, the present invention may employ various integrated circuit components, e.g., memory elements, processing elements, logic elements, look-up tables, and the like, which may carry out a variety of functions under the control of one or more microprocessors or other control devices. Similarly, the software elements of the present invention may be implemented with any programming or scripting language such as C, C++, Java, COBOL, assembler, PERL, Visual Basic, SQL Stored Procedures, extensible markup language (XML), with the various algorithms being implemented with any combination of data structures, objects, processes, routines or other programming elements. Further, it should be noted that the present inven-

tion may employ any number of conventional techniques for data transmission, signaling, data processing, network control, and the like. Still further, the invention may include cryptography. For a basic introduction of cryptography and network security, the following may be helpful references: (1) "Applied Cryptography: Protocols, Algorithms, And Source Code In C," by Bruce Schneier, published by John Wiley & Sons (second edition, 1996); (2) "Java Cryptography" by Jonathan Knudson, published by O'Reilly & Associates (1998); (3) "Cryptography & Network Security: Principles & Practice" by William Stallings, published by Prentice Hall; all of which are hereby incorporated by reference.

[0160] It will be appreciated, that many applications of the present invention could be formulated. One skilled in the art will appreciate that the network may include any system for exchanging data or transacting business, such as the Internet, an intranet, an extranet, WAN, LAN, satellite communications, and/or the like. It is noted that the network may be implemented as other types of networks, such as an interactive television (ITV) network. The parties may interact with the system via any input device such as a keyboard, mouse, kiosk, personal digital assistant, handheld computer (e.g., Palm Pilot®), cellular phone and/or any suitable communication or data input modality. Similarly, the invention could be used in conjunction with any suitable personal computer, network computer, workstation, minicomputer, mainframe, or the like running any operating system such as any version of Windows, Windows NT, Windows2000, Windows 98, Windows 95, Ma-cOS, OS/2, BeOS, Linux, UNIX, Solaris or the like. Moreover, although the invention is frequently described herein as being implemented with TCP/IP communications protocols, the invention may also be implemented using IPX, Appletalk, IP-6, NetBIOS, OSI or any number of existing or future protocols. Moreover, the system contemplates the use, sale or distribution of any goods, services or information over any network having similar functionality described herein.

[0161] The computing units may be connected with each other via a data communication network. If the network is in the nature of a public network, it may be advantageous to presume the network to be insecure and open to eavesdroppers. In the illustrated implementation, the network may comprise the Internet. In this context, the computers may or may not be connected to the internet at all times. For instance, the customer computer may employ a modem to occasionally connect to the internet, whereas the bank computing center may maintain an intermittent or permanent connection to the internet. Specific information related to the protocols, standards, and application software utilized in connection with the Internet is generally known to those skilled in the art and, as such, need not be detailed herein. See, for example, Dilip Naik, "Internet Standards and Protocols" (1998); "Java 2 Complete", various authors, (Sybex 1999); Deborah Ray and Eric Ray, "Mastering HTML 4.0" (1997); and Loshin, "TCP/IP Clearly Explained" (1997), the contents of which are hereby incorporated by reference.

[0162] The various system components may be suitably coupled to the network via data links including a variety of communications media and protocols such as, for example, a connection to an Internet Service Provider (ISP) over the local loop as is typically used in connection with standard modem communication, cable modem, Dish networks, ISDN, Digital Subscriber Line (DSL), or various wireless communication methods. The system components may inde-

pendently, separately or collectively reside within a local area network (LAN) which interfaces to network via a leased line (T1, D3, etc.) or other desired communication methods. See, e.g., Gilbert Held, "Understanding Data Communications" (1996), hereby incorporated by reference.

[0163] As used herein, the term "end user", "consumer", "customer", "cardmember", "business" or "merchant" may be used interchangeably with each other, and each shall mean any person, entity, machine, hardware, software or business. A bank may be part of the system, but the bank may represent other types of card issuing institutions, such as credit card companies, card sponsoring companies, or third party issuers under contract with financial institutions. It is further noted that other participants may be involved in some phases of the transaction, such as an intermediary settlement institution, but these participants are not shown.

[0164] Each participant is equipped with a computing device to facilitate online commerce transactions. The customer has a computing unit in the form of a personal computer, although other types of computing units may be used including laptops, notebooks, hand held computers, set-top boxes, touch-tone telephones and the like. The merchant has a computing unit implemented in the form of a computer-server, although other implementations are contemplated by the invention. The bank has a computing center shown as a main frame computer. However, the bank computing center may be implemented in other forms, such as a mini-computer, a PC server, a network of computers, or the like.

[0165] The merchant computer and the bank computer may be interconnected via a second network, referred to as a payment network. The payment network which may be part of certain transactions represents existing proprietary networks that presently accommodate transactions for credit cards, debit cards, and other types of financial/banking cards. The payment network is a closed network that is assumed to be secure from eavesdroppers. Exemplary transaction networks may include the American Express®, VisaNet® and the Veriphone® networks.

[0166] The electronic commerce system may be implemented at the customer and issuing bank. In an exemplary implementation, the electronic commerce system is implemented as computer software modules loaded onto the customer computer and the banking computing center. The merchant computer does not require any additional software to participate in the online commerce transactions supported by the online commerce system.

[0167] An "account" or "account number", as used herein, may include any device, code, number, letter, symbol, digital certificate, smart chip, digital signal, analog signal, biometric or other identifier/indicia suitably configured to allow the consumer to access, interact with or communicate with the system such as, for example, one or more of an authorization/access code, personal identification number (PIN), Internet code, other identification code, and/or the like which may optionally be located on or associated with a rewards card, charge card, credit card, debit card, prepaid card, telephone card, smart card, magnetic stripe card, bar code card, transponder, radio frequency card or an associated account. The account number may be distributed and stored in any form of plastic, electronic, magnetic, radio frequency, wireless, audio and/or optical device capable of transmitting or downloading data from itself to a second device. A customer account number may be, for example, a sixteen-digit credit card number, although each credit provider has its own numbering system,

such as the fifteen-digit numbering system used by American Express. Each company's credit card numbers comply with that company's standardized format such that the company using a sixteen-digit format will generally use four spaced sets of numbers, as represented by the number "0000 0000 0000 0000". The first five to seven digits are reserved for processing purposes and identify the issuing bank, card type, etc. In this example, the last (sixteenth) digit is used as a sum check for the sixteen-digit number. The intermediary eight-to-ten digits are used to uniquely identify the customer. A merchant account number may be, for example, any number or alpha-numeric characters that identifies a particular merchant for purposes of card acceptance, account reconciliation, reporting, or the like.

[0168] As will be appreciated by one of ordinary skill in the art, the present invention may be embodied as a method, a data processing system, a device for data processing, and/or a computer program product. Accordingly, the present invention may take the form of an entirely software embodiment, an entirely hardware embodiment, or an embodiment combining aspects of both software and hardware. Furthermore, the present invention may take the form of a computer program product on a computer-readable storage medium having computer-readable program code means embodied in the storage medium. Any suitable computer-readable storage medium may be utilized, including hard disks, CD-ROM, optical storage devices, magnetic storage devices, and/or the like.

[0169] The present invention is described herein with reference to screen shots, block diagrams and flowchart illustrations of methods, apparatus (e.g., systems), and computer program products according to various aspects of the invention. It will be understood that each functional block of the block diagrams and the flowchart illustrations, and combinations of functional blocks in the block diagrams and flowchart illustrations, respectively, can be implemented by computer program instructions. These computer program instructions may be loaded onto a general purpose computer, special purpose computer, or other programmable data processing apparatus to produce a machine, such that the instructions which execute on the computer or other programmable data processing apparatus create means for implementing the functions specified in the flowchart block or blocks.

[0170] These computer program instructions may also be stored in a computer-readable memory that can direct a computer or other programmable data processing apparatus to function in a particular manner, such that the instructions stored in the computer-readable memory produce an article of manufacture including instruction means which implement the function specified in the flowchart block or blocks. The computer program instructions may also be loaded onto a computer or other programmable data processing apparatus to cause a series of operational steps to be performed on the computer or other programmable apparatus to produce a computer-implemented process such that the instructions which execute on the computer or other programmable apparatus provide steps for implementing the functions specified in the flowchart block or blocks.

[0171] Accordingly, functional blocks of the block diagrams and flowchart illustrations support combinations of means for performing the specified functions, combinations of steps for performing the specified functions, and program instruction means for performing the specified functions. It will also be understood that each functional block of the block

diagrams and flowchart illustrations, and combinations of functional blocks in the block diagrams and flowchart illustrations, can be implemented by either special purpose hardware-based computer systems which perform the specified functions or steps, or suitable combinations of special purpose hardware and computer instructions.

[0172] For more information on loyalty systems, transaction systems, electronic commerce systems and digital wallet systems, see, for example, U.S. patent application Ser. No. 09/836,213, filed on Apr. 17, 2001, by inventors Voltmer, et al., and entitled "System And Method For Networked Loyalty Program"; U.S. Continuation-In-Part patent application Ser. No. 10/027,984, was filed on Dec. 20, 2001, by inventors Ariff, et al., and entitled "System And Method For Networked Loyalty Program"; U.S. Continuation-In-Part patent application Ser. No. 10/010,947, filed on Nov. 6, 2001, by inventors Haines, et al., and entitled "System And Method For Networked Loyalty Program"; U.S. Continuation-In-Part patent application Ser. No. 10/084,744, filed on Feb. 26, 2002, by inventors Bishop, et al., and entitled "System And Method For Securing Data Through A PDA Portal"; the Shop AMEX™ system disclosed in U.S. Patent Application Ser. No. 60/230,190, filed Sep. 5, 2000; the MR as Currency™ and Loyalty Rewards Systems disclosed in U.S. Patent Application Ser. No. 60/197,296, filed on Apr. 14, 2000; U.S. Patent Application Ser. No. 60/200,492, filed Apr. 28, 2000; U.S. Patent Application Ser. No. 60/201,114, filed May 2, 2000; the digital wallet system disclosed in U.S. patent application Ser. No. 09/652,899, filed Aug. 31, 2000; the stored value card disclosed in U.S. patent application Ser. No. 09/241,188, filed Feb. 1, 1999; the system for facilitating transactions using secondary transaction numbers disclosed in U.S. patent application Ser. No. 09/800,461, filed Mar. 7, 2001; and also in related U.S. Provisional Patent Application Ser. No. 60/187,620, filed Mar. 7, 2000; U.S. Provisional Patent Application Ser. No. 60/200,625, filed Apr. 28, 2000; U.S. Ser. No. 09/834,478, filed on Apr. 13, 2001 by Chien, et al., and entitled "System And Method For Using Loyalty Points," and U.S. Provisional Patent Application Ser. No. 60/213,323, filed May 22, 2000, all of which are herein incorporated by reference. Other examples of online membership reward systems are disclosed in Netcentives, U.S. Pat. No. 5,774,870, issued on Jun. 30, 1998, and U.S. Pat. No. 6,009,412, issued on Dec. 29, 1999, both of which are hereby incorporated by reference.

[0173] Benefits, other advantages, and solutions to problems have been described herein with regard to specific embodiments. However, the benefits, advantages, solutions to problems, and any element(s) that may cause any benefit, advantage, or solution to occur or become more pronounced are not to be construed as critical, required, or essential features or elements of any or all the claims or the invention. As used herein, the terms "comprises", "comprising", or any other variation thereof, are intended to cover a non-exclusive inclusion, such that a process, method, article, or apparatus that comprises a list of elements does not include only those elements but may include other elements not expressly listed or inherent to such process, method, article, or apparatus. Further, no element described herein is required for the practice of the invention unless expressly described as "essential" or "critical".

[0174] In the foregoing specification, the invention has been described with reference to specific embodiments. However, it will be appreciated that various modifications and

changes can be made without departing from the scope of the present invention as set forth in the claims below. The specification and figures are to be regarded in an illustrative manner, rather than a restrictive one, and all such modifications are intended to be included within the scope of present invention. Accordingly, the scope of the invention should be determined by the appended claims and their legal equivalents, rather than by the examples given above. For example, the steps recited in any of the method or process claims may be executed in any order and are not limited to the order presented in the claims.

1-21. (canceled)

22. A method, comprising:

creating, at a computer system, a first profile for a primary member associated with a loyalty points account; and

creating, at the computer system, a second profile for a supplementary member associated with the loyalty points account, wherein the second profile specifies that the supplementary member is authorized with respect to the loyalty points account.

23. The method of claim 22, wherein the second profile specifies that the supplementary member is authorized to redeem loyalty points associated with the loyalty points account.

24. The method of claim 22, wherein the second profile specifies that the supplementary member is authorized to earn loyalty points associated with the loyalty points account.

25. The method of claim 23, wherein the second profile specifies that the supplementary member is authorized to redeem all of the loyalty points associated with the loyalty points account.

26. The method of claim 23, wherein the second profile specifies that the supplementary member is authorized to redeem only those loyalty points associated with the loyalty points account that the primary member has authorized for redemption.

27. The method of claim 23, wherein the second profile specifies that the supplementary member is authorized to earn loyalty points for the loyalty points account.

28. The method of claim 22, wherein the second profile specifies that the supplementary member is allowed to redeem all loyalty points associated with the loyalty points account that are earned in a specific geographic area.

29. The method of claim 22, wherein the first profile includes a primary member ID that is associated with a card, and wherein the second profile includes a supplementary member ID associated with a card.

30. The method of claim 22, further comprising:

creating, at the computer system, one or more additional profiles for additional supplementary members authorized with respect to the loyalty points account.

31. The method of claim 22, further comprising:

reporting activity related to the loyalty points account to the primary member, but not to the supplementary member.

32. A method, comprising:

receiving, at a computer system, information indicative of activity of a supplementary member associated with an aggregate consumer loyalty account, wherein a primary member is also associated with the aggregate consumer loyalty account; and

updating, at the computer system, the aggregate consumer loyalty account based on the activity of the supplementary member.

33. The method of claim 32, wherein the activity corresponds to loyalty points earned by the supplementary member.

34. The method of claim 32, wherein the activity corresponds to loyalty points redeemed by the supplementary member.

35. The method of claim 32, wherein the supplementary member and the primary member are associated with different geographic areas.

36. The method of claim 32, wherein the activity corresponds to the supplementary member visiting a web site.

37. A method, comprising:

receiving, at a computer system, information from a primary member identifying one or more supplementary members to be associated with a consumer loyalty account; and

establishing, at the computer system, the consumer loyalty account, wherein the established consumer loyalty account is associated with the primary member and the one or more supplementary members;

wherein the computer system permits loyalty points earned by the primary member or one of the supplementary members to be associated with the established consumer loyalty account.

38. The method of claim 37, further comprising:

receiving, at the computer system, information from the primary member indicating that a particular supplementary member is authorized to redeem loyalty points associated with the established consumer loyalty account.

39. The method of claim 37, further comprising:

receiving, at the computer system, information from a first of the one or more supplementary members indicating that a second of the one or more supplementary members is authorized to redeem loyalty points associated with the established consumer loyalty account that have been earned by the first supplementary member.

40. The method of claim 37, further comprising:

receiving, at the computer system, information from the primary member indicating that a particular supplementary member is limited to accessing and viewing those number of loyalty points associated with the established consumer loyalty account that have been earned by the particular supplementary member in a specified geographic area.

41. The method of claim 37, further comprising:

reporting activity related to the established consumer loyalty account to the primary member but not to any of the supplementary members.

* * * * *