



(11)

EP 4 516 147 A1

(12)

EUROPEAN PATENT APPLICATION
published in accordance with Art. 153(4) EPC

(43) Date of publication:

05.03.2025 Bulletin 2025/10

(51) International Patent Classification (IPC):

A42B 3/22 ^(2006.01) **A42B 3/06** ^(2006.01)

(21) Application number: **23796636.1**

(52) Cooperative Patent Classification (CPC):

A42B 3/06; A42B 3/22

(22) Date of filing: **30.03.2023**

(86) International application number:

PCT/KR2023/004277

(87) International publication number:

WO 2023/210987 (02.11.2023 Gazette 2023/44)

(84) Designated Contracting States:

**AL AT BE BG CH CY CZ DE DK EE ES FI FR GB
GR HR HU IE IS IT LI LT LU LV MC ME MK MT NL
NO PL PT RO RS SE SI SK SM TR**

Designated Extension States:

BA

Designated Validation States:

KH MA MD TN

(71) Applicant: **HJC Corp.**

Yongin-si, Gyeonggi-do 17127 (KR)

(72) Inventor: **LEE, Yun Haeng**

Hwaseong-si, Gyeonggi-do 18420 (KR)

(74) Representative: **Treeby, Philip David William**

Maucher Jenkins

Seventh Floor Offices

Artillery House

11-19 Artillery Row

London SW1P 1RT (GB)

(30) Priority: **28.04.2022 KR 20220052614**

(54) **HEAD PROTECTION DEVICE**

(57) A head protection device is disclosed. A head protection device according to an aspect of the present invention comprises: an outer frame having a receiving space formed therein; a main visor covering a portion of the receiving space and rotatably coupled to the outer frame; and a sub-visor covering another portion of the receiving space and coupled to the main visor so as to be rotatable in one direction toward the main visor and in another direction opposite thereto, wherein the sub-visor may be rotatably configured between a first position, in which an outwardly exposed area is minimized, and a second position, in which an outwardly exposed area is maximized, so that the area of the receiving space covered by the main visor and the sub-visor is adjusted.

[FIG. 8]

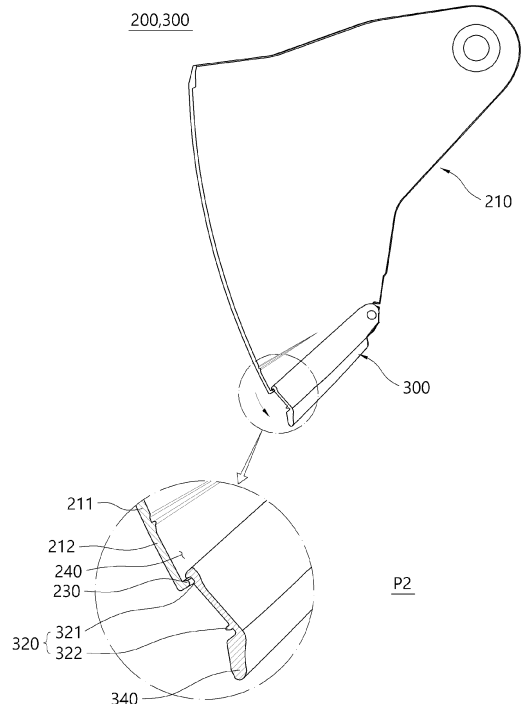

EP 4 516 147 A1

Description

[Technical Field]

5 **[0001]** The present invention relates to a head protection device, and more specifically to head protection device with a structure that can reduce driving noise and eye irritation caused by the inflow of outside air.

[Background Art]

10 **[0002]** A head protection device, commonly referred to as a helmet, is used to protect the wearer's head.

[0003] Helmets can be classified into half face, open face and full face depending on the degree to which the helmets cover the wearer's head. Among these, the safest type is the full-face type helmet, which covers most of the wearer's head, including the chin area.

15 **[0004]** However, in the case of full-face type helmets, the weight is considerable, and drivers often experience inconvenience, especially due to problems such as ventilation. Accordingly, recently, open-face type helmets that combine the advantages of half-face type and full-face type have been in the spotlight.

[0005] While driving, outside air is blocked from entering the helmet by a visor provided on the helmet. However, in an open-face type helmet, the lower part of the head, including the wearer's chin, is open. Accordingly, it is possible to prevent a situation where outside air flows in from the front side, but it is difficult to prevent a situation where outside air enters the
20 inside of the helmet through the lower side of the visor.

[0006] If outside air flows into the inside of the helmet, driving noise, which is noise generated by outside air while driving, may be transferred directly to the wearer. Additionally, outside air may flow into the wearer's eyes, thereby making it difficult to secure vision. Therefore, situations may arise where people avoid wearing helmets, which are essential for safety.

25 **[0007]** Korean Patent Laid-Open Publication No. 10-2019-0014960 discloses a helmet. Specifically, it discloses a helmet that includes an air purifying unit provided inside the helmet and can promote air circulation inside the helmet.

[0008] However, the helmet disclosed in the above related art document only discloses a method for purifying the inflow of air, assuming that outside air has already flowed into the interior of the helmet. In other words, the above related art document does not suggest a method for preventing air from flowing into the interior of the helmet.

30 **[0009]** Korean Patent Laid-Open Publication No. 10-2017-0108413 discloses a type variable helmet. Specifically, it discloses a type variable helmet which includes an underface unit that is detachably provided at the bottom of the half-face unit and formed to surround the lower head area of the user.

[0010] However, the above related art document only presents a method for changing the type of helmet itself. In other words, the purpose of the helmet disclosed in the above related art document is to change a half-face type helmet into a full-face type helmet by attaching additional members. As a result, the above related art document does not disclose a method
35 for preventing the inflow of outside air while maintaining a half-face type.

[0011] Furthermore, the above related art documents do not disclose a method for adjusting air resistance or air inflow during driving by varying the area of a visor itself.

Korean Patent Laid-Open Publication No. 10-2019-0014960 (February 13, 2019)

40 Korean Patent Laid-Open Publication No. 10-2017-0108413 (September 27, 2017)

[Disclosure]

[Technical Problem]

45 **[0012]** The present invention has been devised to solve the above problems, and an object of the present invention is to provide a head protection device with a structure in which the area of a visor can be easily varied.

[0013] Another object of the present invention is to provide a head protection device with a structure that can minimize the amount of outside air flowing into the interior while driving.

50 **[0014]** Still another object of the present invention is to provide a head protection device with a structure that can minimize driving noise generated during driving.

[0015] Still another object of the present invention is to provide a head protection device with a structure in which the area of a visor can be varied without additionally providing a separate member.

55 **[0016]** Still another object of the present invention is to provide a head protection device with a structure in which the area of a visor can be easily varied through simple operation.

[0017] Still another object of the present invention is to provide a head protection device with a structure that can stably maintain a variable area.

[0018] The problems of the present invention are not limited to the problems mentioned above, and other problems that

are not mentioned will be clearly understood by those skilled in the art from the description below.

[Technical Solution]

5 **[0019]** According to an aspect of the present invention, provided is a head protection device, including an outer frame having a receiving space formed therein; a main visor configured to cover a portion of the receiving space and rotatably coupled to the outer frame; and a sub-visor configured to cover another portion of the receiving space and coupled to the main visor so as to be rotatable in one direction toward the main visor and in another direction opposite thereto, wherein the sub-visor is rotatably configured between a first position, in which an outwardly exposed area is minimized, and a second position, in which an outwardly exposed area is maximized such that the area of the receiving space covered by the main visor and the sub-visor is adjusted.

10 **[0020]** In this case, the head protection device may be provided, wherein a surface area of the sub-visor is formed to be smaller than a surface area of the main visor.

15 **[0021]** In addition, the head protection device may further include a visor coupler respectively coupled to the main visor and the sub-visor, so as to rotatably support the sub-visor.

[0022] In this case, the head protection device may be provided, wherein the visor coupler includes a sub-coupling protrusion which is formed to protrude toward the sub-visor such that the sub-visor is rotatably coupled thereto.

20 **[0023]** In addition, the head protection device may be provided, wherein the sub-visor includes a sub-coupling hole which is positioned to be adjacent to one end facing the visor coupler, and is formed through an interior thereof such that the sub-coupling protrusion is rotatably coupled thereto.

[0024] In this case, the head protection device may be provided, wherein the visor coupler includes a limiting edge which forms one edge facing the sub-visor, and is configured to contact the sub-visor and limit a rotation angle of the sub-visor according to a rotation of the sub-visor.

25 **[0025]** In addition, the head protection device may be provided, wherein the sub-visor includes a sub-edge which forms one edge facing the visor coupler, and is arranged to face the limiting edge, wherein when the sub-visor is located at the first position, the sub-edge and the limiting edge are spaced apart, and wherein when the sub-visor is located at the second position, the sub-edge and the limiting edge are configured to contact each other such that the rotation of the sub-visor is limited.

30 **[0026]** In this case, the head protection device may be provided, wherein the main visor includes a main body which extends to surround the receiving space, and extends a predetermined length along a rotational direction of the main visor.

[0027] In addition, the head protection device may be provided, wherein the main body includes a first part configured to form a portion of the main body, and exclusively cover the receiving space; and a second part configured to form another portion of the main body, be continuous with the first part, and overlap the sub-visor at the first position, wherein a thickness of the second part is formed to be less than or equal to a thickness of the first part.

35 **[0028]** In this case, the head protection device may be provided, wherein the main visor includes a main support protrusion which is formed to protrude toward the sub-visor at an end of the second part, and wherein the main support protrusion is located between an upper end of the sub-visor and a lower end of the sub-visor.

40 **[0029]** In addition, the head protection device may be provided, wherein the sub-visor includes a sub-body configured to extend a predetermined length along a rotational direction of the sub-visor; and a sub-protrusion formed to extend from the sub-body toward the main visor and being in contact with or spaced apart from the main support protrusion by movement of the sub-visor.

45 **[0030]** In this case, the head protection device may be provided, wherein the sub-protrusion is provided in plurality, wherein when the sub-visor is located at the first position, any one of a plurality of sub-protrusions is positioned to be spaced apart from the main support protrusion, and wherein when the sub-visor is located at the second position, the any one of a plurality of sub-protrusions is supported by being in contact with the main support protrusion.

[0031] In addition, the head protection device may further include a grasping protrusion formed to extend in a direction away from the main support protrusion at one end of the sub-body, and having an end in the extension direction positioned on an outside of the main visor.

50 **[0032]** In this case, the head protection device may be provided, wherein when the sub-visor is located at the first position, the grasping protrusion is in contact with the main support projection, and wherein when the sub-visor is located at the second position, the grasping protrusion is spaced apart from the main support protrusion.

[0033] In addition, the head protection device may be provided, wherein the grasping protrusion is formed to extend obliquely at a predetermined angle with the sub-body.

55 [Advantageous Effects]

[0034] According to the above configuration, the area of a visor of the head protection device according to an embodiment of the present invention can be easily varied.

[0035] In addition, according to the above configuration, the amount of outside air flowing into the head protection device according to an embodiment of the present invention while driving can be minimized.

[0036] In addition, according to the above configuration, the head protection device according to an embodiment of the present invention can minimize driving noise generated while driving.

[0037] In addition, according to the above configuration, the area of a visor of the head protection device according to an embodiment of the present invention can be varied without additionally providing a separate member.

[0038] In addition, according to the above configuration, the area of a visor of the head protection device according to an embodiment of the present invention can be easily varied through simple operation.

[0039] In addition, according to the above configuration, the head protection device according to an embodiment of the present invention can be stably maintained in a state where the area is varied.

[0040] The effects of the present invention are not limited to the effects described above, and should be understood to include all effects that can be inferred from the configuration of the invention described in the detailed description or claims of the present invention.

[Description of Drawings]

[0041]

FIG. 1 is a perspective view illustrating a head protection device according to an embodiment of the present invention.

FIG. 2 is an exploded perspective view illustrating the configuration of the head protection device of FIG. 1.

FIG. 3 is an exploded perspective view illustrating a main visor, a sub-visor and a visor coupler provided in the head protection device of FIG. 1.

FIG. 4 is a rear view and a partially enlarged view illustrating a main visor provided in the head protection device of FIG. 1.

FIG. 5 is a front view and a partially enlarged view illustrating a sub-visor provided in the head protection device of FIG. 1.

FIG. 6 is a perspective view illustrating a visor coupler provided in the head protection device of FIG. 1.

FIG. 7 is a side cross-sectional view and a partially enlarged view illustrating a sub-visor provided in the head protection device of FIG. 1 moved to the first position.

FIG. 8 is a side cross-sectional view and a partially enlarged view illustrating a sub-visor provided in the head protection device of FIG. 1 which is moved to the second position.

FIG. 9 is a conceptual diagram illustrating a flow of air generated outside the head protection device of FIG. 1, when the sub-visor of the head protection device of FIG. 1 is maintained in the first position.

FIG. 10 is a conceptual diagram illustrating a flow of air generated outside the head protection device of FIG. 1, when the sub-visor of the head protection device of FIG. 1 is moved to the second position.

[Modes of the Invention]

[0042] Hereinafter, with reference to the attached drawings, embodiments of the present invention will be described in detail so that those skilled in the art can easily practice the present invention. The present invention may be implemented in many different forms and is not limited to the embodiments described herein. In order to clearly explain the present invention, parts that are not related to the description have been omitted in the drawings, and identical or similar components are assigned the same reference numerals throughout the specification.

[0043] Terms and words used in the present specification and claims should not be construed as limited to their usual or dictionary definition, and they should be interpreted as a meaning and concept consistent with the technical idea of the present invention based on the principle that inventors may appropriately define the terms and concept in order to describe their own invention in the best way.

[0044] Accordingly, the embodiments described in the present specification and the configurations shown in the drawings correspond to preferred embodiments of the present invention, and do not represent all the technical spirit

of the present invention, and thus, the configurations may have various examples of equivalent and modification that can replace them at the time of filing the present invention.

[0045] In the following description, in order to clarify the characteristics of the present invention, the descriptions of some components may be omitted.

5 **[0046]** The term "eye irritation" used in the following description refers to any situation in which outside air enters the wearer's eyes and causes the obstruction of vision. In an embodiment, eye irritation may be used to refer to a situation in which it is difficult for the wearer to secure normal vision due to outside air coming into direct contact with the wearer's cornea.

[0047] The terms "top", "bottom", "left", "right", "front" and "back" used in the following description will be understood with reference to the coordinate system illustrated in FIG. 1.

10 **[0048]** Referring to FIGS. 1 to 6, a head protection device 10 according to an embodiment of the present invention is disclosed.

[0049] The head protection device 10 according to an embodiment of the present invention includes a main visor 200 and a sub-visor 300 to block outside air flowing in from the front side while driving. The sub-visor 300 is configured to have a variable area exposed to the outside such that the flow of outside air may be controlled.

15 **[0050]** With the above configuration, noise caused by outside air during driving may be minimized. In addition, the amount of air flowing into the inside of the head protection device 10 through one open side of the head protection device 10, which is the lower side in the illustrated embodiment, may be minimized. As a result, eye irritation that may occur when incoming air flows into the wearer's eyes can be minimized.

20 **[0051]** Referring to FIGS. 1 to 8, the head protection device 10 according to the illustrated embodiment includes an outer frame 100, a main visor 200, a sub-visor 300 and a visor coupler 400.

[0052] The outer frame 100 forms the outer shape of the head protection device 10. A space is formed inside the outer frame 100 to receive the wearer's head (head part). The outer frame 100 may protect the wearer's head part from external impacts and the like.

25 **[0053]** The outer frame 100 may be shaped to accommodate and protect the wearer's head part and minimize air resistance while driving. In the illustrated embodiment, the outer frame 100 is shaped like a sphere, similar to the wearer's head part.

[0054] The main visor 200 is rotatably coupled to the outer frame 100. Additionally, the sub-visor 300, which is rotatably coupled to the main visor 200, may also be said to be rotatably coupled.

30 **[0055]** A visor coupler 400 may be coupled to the outer frame 100. Specifically, the visor coupler 400 is coupled to the main visor 200 and the sub-visor 300, respectively, such that the visor coupler 400 may be coupled to or separated from the outer frame 100 by rotation of the main visor 200.

[0056] In the illustrated embodiment, the outer frame 100 includes a receiving space 110.

35 **[0057]** The receiving space 110 is a space formed inside the outer frame 100. The receiving space 110 accommodates the wearer's head part. The receiving space 110 is partially surrounded by the outer frame 100. Another portion of the receiving space 110 is formed to be open. A part of the other portion of the receiving space 110, which is the front side in the illustrated embodiment, is surrounded to be opened or closed by the main visor 200 and the sub-visor 300.

[0058] Another portion of the receiving space 110, which is the lower side in the illustrated embodiment, is formed to be open. The wearer may accommodate his or her head part through the openly formed lower portion of the receiving space. 40 The part of the other portion of the receiving space 110 may be covered or opened by the main visor 200.

[0059] The main visor 200 is rotatably coupled to the outer frame 100 to open or close the part of the other portion of the receiving space 110. During driving, the main visor 200 may close the part of the other portion of the receiving space 110 to prevent front-side air from flowing into the receiving space 110.

45 **[0060]** The main visor 200 is rotatably coupled to the outer frame 100. In the illustrated embodiment, with respect to the right side, the main visor 200 may be rotated clockwise and moved upward to open the front side of the receiving space 110.

[0061] In the illustrated embodiment, with respect to the right side, the main visor 200 may be rotated counterclockwise and moved downward. In this state, the main visor 200 may close the front side of the receiving space 110.

[0062] The main visor 200 is coupled to the sub-visor 300. The sub-visor 300 is rotatably coupled to the main visor 200 such that the area overlapping with the main visor 200 may be varied. Accordingly, the flow of outside air in the head protection device 10 may be controlled to minimize driving noise and the inflow of outside air.

50 **[0063]** In the illustrated embodiment in FIGS. 3 to 4, the main visor 200 includes a main body 210, a main coupling groove 220, a main support protrusion 230 and a main support space 240.

[0064] The main body 210 forms the body of the main visor 200. The main body 210 may be formed in a shape corresponding to the open portion of the receiving space 110, which is the front side in the illustrated embodiment. 55 Additionally, the main body 210 may be formed in a shape corresponding to the shape of the outer frame 100.

[0065] In the illustrated embodiment, the main body 210 is rounded to be convex toward the outside of the receiving space 110, and is formed to extend along the top-bottom and left-right directions of the receiving space 110. In other words, the horizontal cross-section of the main body 210 has an arc shape whose center is located in the receiving space 110 and

extends in the width direction of the receiving space 110, that is, in the left-right direction. Accordingly, it will be understood that the main body 210 has a curved shape extending along both the height and width directions of the receiving space 110.

[0066] The main body 210 extends to surround the receiving space 110. In the illustrated embodiment, the main body 210 extends by surrounding the left and right portions and the front side of the receiving space 110. The main body 210 is formed to have a predetermined height. That is, the main body 210 is formed to have a predetermined height along the rotation direction of the main visor 200, which is the top-bottom direction in the illustrated embodiment.

[0067] In the illustrated embodiment, the main body 210 includes a first part 211 and a second part 212.

[0068] The first part 211 forms a portion of the main body 210. The first part 211 independently covers a portion of the front side of the receiving space 110 to prevent a situation in which outside air flows into the receiving space 110 through the front side during driving. In the illustrated embodiment, the first part 211 forms the upper side of the main body 210.

[0069] The first part 211 has ends in an extension direction in the width direction, which are a left-side end and a right-side end the illustrated embodiment, rotatably coupled to the outer frame 100, respectively. That is, in the embodiment illustrated in FIGS. 3 and 4, the inner side surface of the first part 211 (i.e., a surface facing the receiving space 110) is provided with a coupler (reference numeral not assigned) which is rotatably coupled to the outer frame 100.

[0070] The first part 211 may be formed to have a larger area than the second part 212. Accordingly, it can be said that the first part 211 mainly performs the role of preventing the inflow of outside air located on the front side during driving.

[0071] The first part 211 is continuous with the second part 212.

[0072] The second part 212 forms another portion of the main body 210. The second part 212 covers another portion on the front side of the receiving space 110 to prevent a situation where outside air flows into the receiving space 110 through the front side during driving. In the illustrated embodiment, the second part 212 forms the lower side of the main body 210.

[0073] The sub-visor 300 is rotatably coupled to an end of an extension direction in the width direction of the second part 212. Specifically, the sub-visor 300 is rotatably coupled to the second part 212 by the visor coupler 400. As the sub-visor 300 rotates, the second part 212 may overlap the sub-visor 300.

[0074] The second part 212 may be formed to have a smaller area than the first part 211. Additionally, the second part 212 may be formed to have a thickness smaller than that of the first part 211. As will be described below, the sub-visor 300 which is coupled to the second part 212 may be rotated to vary the area overlapping with the second part 212 (refer to FIGS. 7 and 8).

[0075] Due to the structure described above, the thickness of the second part 212 is formed to be smaller than that of the first part 211, thereby preventing an excessive increase in the overall thickness of the main body 210.

[0076] Although reference numerals are not assigned, a protrusion may be formed to be adjacent to a portion where the first part 211 and the second part 212 are continuous. The protrusion may be inserted or extracted into a space formed between a pair of first sub-protrusions 321 provided on the sub-visor 300. In the above embodiment, the coupling state of the sub-visor 300 and the main visor 200 may be stably maintained.

[0077] The main coupling groove 220 is a portion where the main visor 200 is coupled to the visor coupler 400. The main coupling groove 220 is recessed at a corner of the main body 210 such that a main coupling protrusion 410 provided on the visor coupler 400 may be inserted.

[0078] The main coupling groove 220 may be formed at a corner of the main body 210 facing the visor coupler 400. In the embodiment illustrated in FIG. 4, the main coupling groove 220 is located at a corner facing the visor coupler 400 among the ends in the width direction, that is, at a lower edge on the back side.

[0079] The main coupling groove 220 may be formed at a plurality of positions. A plurality of main coupling grooves 220 may each be coupled to different visor couplers 400. In the illustrated embodiment, the main engaging groove 220 is located at the left-side and right-side ends of the lower side on the back side of the main body 210, respectively.

[0080] The main coupling groove 220 may be formed in a shape corresponding to the shape of the main coupling protrusion 410. In the illustrated embodiment, the main coupling groove 220 is formed in a straight line and recessed for a predetermined length.

[0081] In the illustrated embodiment, the main coupling groove 220 includes a first main coupling groove 221 and a second main coupling groove 222.

[0082] The first main coupling groove 221 receives any one main coupling protrusion 410 among a plurality of main coupling protrusions 410 in a withdrawable manner. The first main coupling groove 221 is recessed in one edge of the lower edge on the back side of the main body 210 that extends obliquely in the top-bottom direction.

[0083] The second main coupling groove 222 is located adjacent to the first main coupling groove 221.

[0084] The second main coupling groove 222 is configured to receive another main coupling protrusion 410 among the plurality of main coupling protrusions 410 in a withdrawable manner. The second main coupling groove 222 is recessed in another edge of the lower edge on the back side of the main body 210 that extends obliquely in the front-back direction.

[0085] The directions in which the first main coupling groove 221 and the second main coupling groove 222 are recessed may be formed differently. Accordingly, the main visor 200 and the visor coupler 400 are supported and coupled in different directions such that the coupling state between the main visor 200 and the visor coupler 400 may be stably maintained.

[0086] Although reference numerals are not assigned, a main coupling hole may be provided at an end of the second

part 212 of the main body 210, adjacent to the main coupling groove 220. A sub-coupling protrusion 420 of the visor coupler 400 may be rotatably coupled to the main coupling hole (reference numeral not assigned). Accordingly, the main visor 200 may rotatably support the sub-visor 300.

5 **[0087]** The main support protrusion 230 limits the rotation distance of the sub-visor 300 which is rotatably coupled to the main visor 200. The rotation distance in the direction in which the sub-visor 300 is spaced apart from the main visor 200 may be limited by the main support protrusion 230.

[0088] The main support protrusion 230 is formed on the second part 212 of the main body 210. The main support protrusion 230 is formed to protrude toward the sub-visor 300 on one surface among the surfaces of the second part 212 facing the receiving space 110, or on the rear side surface in the illustrated embodiment.

10 **[0089]** The main support protrusion 230 is located at an end of the main body 210 in the height direction. In the illustrated embodiment, the main support protrusion 230 is located at one end in the height direction of the second part 212, that is, at the lower end. In other words, the main support protrusion 230 is located at one end opposite to the first part 211.

[0090] The main support protrusion 230 may be located at each end of the sub-visor 300 in the height direction, between the upper end and the lower end in the illustrated embodiment. As the sub-visor 300 rotates, the main support protrusion 15 230 may be positioned adjacent to or spaced apart from the sub-protrusion 320.

[0091] The main support protrusion 230 extends along a direction in which the second part 212 extends, which is the left-right direction in the illustrated embodiment. As described above, since the main body 210 on which the second part 212 is formed is formed as a curved surface having an arc-shaped cross-section, it will be understood that the main support protrusion 230 may also have an arc-shaped cross-section.

20 **[0092]** The main support protrusion 230 may be located adjacent to any one of a first sub-protrusion 321 or a second sub-protrusion 322 of the sub-visor 300. As the sub-visor 300 rotates, the main support protrusion 230 may be inserted or extracted into a space formed between a pair of first sub-protrusions 321 or a space formed between a second sub-protrusion 322 and a grasping protrusion 340.

25 **[0093]** That is, referring to FIGS. 7 and 8, at a first position (P1), that is, in a state where the area in which the sub-visor 300 is exposed to the outside is minimized, the main support protrusion 230 may be positioned to be adjacent to the second sub-protrusion 322. In this state, the main support protrusion 230 is inserted into a space formed between the second sub-protrusion 322 and the grasping protrusion 340.

[0094] Additionally, in a second position (P2), that is, in a state where the area in which the sub-visor 300 is exposed to the outside is maximized, the main support protrusion 230 may be positioned to be adjacent to the first sub-protrusion 321. 30 In this state, the main support protrusion 230 is inserted into a space formed between a pair of first sub-protrusions 321.

[0095] In particular, at the second position (P2), the main support protrusion 230 supports the first sub-protrusion 321 located on the upper side of the pair of first sub-protrusions 321, thereby restricting the rotation distance of the sub-visor 300 and preventing the arbitrary departure of the sub-visor 300.

35 **[0096]** The main support space 240 is a space formed between the second part 212 of the main body 210 and the sub-visor 300. In other words, the main support space 240 may be defined as a surface among the surfaces of the second part 212 facing the receiving space 110, that is, a space formed between each end of the inner surface in the height direction of the second part 212.

[0097] The main support space 240 may be defined as a space in which the sub-protrusion 320 of the sub-visor 300 moves. The sub-protrusion 320 may be rotated together with the sub-visor 300 to move in a direction in which the main support space 240 extends, which is the top-bottom direction in the illustrated embodiment.

40 **[0098]** At the first position (P1), the main support space 240 may be partially surrounded by the sub-body 310 of the sub-visor 300. That is, in the embodiment illustrated in FIGS. 7 and 8, the front side of the main support space 240 is surrounded by the inner side surface of the second part 212, and the rear side is surrounded by the front side surface of the sub-body 310.

45 **[0099]** Accordingly, it can be said that the inner side surface of the second part 212 and the front side surface of the sub-body 310 are spaced apart from each other with the main support space 240 therebetween.

[0100] At the second position (P2), the main support space 240 communicates with the receiving space 110, and the lower side thereof may be partially surrounded by the sub-body 310.

50 **[0101]** Referring again to FIGS. 1 to 3, the head protection device 10 according to an embodiment of the present invention includes a sub-visor 300.

[0102] The sub-visor 300 is rotatably coupled to the main visor 200, and is configured to vary an area that blocks outside air on the front side during driving. In other words, the sub-visor 300 serves to expand the function of the main visor 200.

[0103] The sub-visor 300 may be formed to have a smaller surface area than the main visor 200. The sub-visor 300 may be arranged such that part or all thereof covers (or overlaps) the main visor 200.

55 **[0104]** The sub-visor 300 may be rotated between a first position (P1) received in the second part 212 of the main visor 200 and a second position (P2) exposed in the second part 212 (refer to FIG. 7 to 8). Accordingly, the first position (P1) may be defined as a state in which the area exposed to the outside of the sub-visor 300 is minimized, and the second position (P2) may be defined as a state in which the area exposed to the outside of the sub-visor 300 is maximized.

[0105] The sub-visor 300 is rotatably coupled to the main visor 200. Specifically, the sub-visor 300 is rotatably coupled to the main visor 200 via the visor coupler 400.

[0106] In the illustrated embodiment, with respect to the right side, the sub-visor 300 may be rotated clockwise and moved upward. The state may be defined as the first position (P1) where the area in which the sub-visor 300 is exposed to the outside is minimized. Accordingly, it will be understood that at the first position (P1), the overlapping area between the sub-visor 300 and the main visor 200 is maximized.

[0107] Additionally, in the illustrated embodiment, with respect to the right side, the sub-visor 300 may be rotated counterclockwise and moved downward. The state may be defined as the second position (P2) where the area in which the sub-visor 300 is exposed to the outside is maximized. Accordingly, it will be understood that at the second position (P2), the overlapping area between the sub-visor 300 and the main visor 200 is minimized. That is, the area covered by the main visor 200 or the sub-visor 300 of the receiving space 110 may be adjusted by rotating the sub-visor 300.

[0108] In the embodiment illustrated in FIG. 5, the sub-visor 300 includes a sub-body 310, a sub-protrusion 320, a sub-coupling part 330 and a grasping protrusion 340.

[0109] The sub-body 310 forms the body of the sub-visor 300. The sub-body 310 may be formed in a shape corresponding to the open portion among the portions of the receiving space 110, or the front side in the illustrated embodiment. Additionally, the sub-body 310 may be formed in a shape corresponding to the shape of the outer frame 100.

[0110] In the illustrated embodiment, the sub-body 310 is rounded to be convex toward the outside of the receiving space 110 and extends along the top-bottom direction and left-right direction of the receiving space 110. The sub-body 310 is formed to have a predetermined height. That is, the sub-body 310 is formed to have a predetermined height along the rotation direction of the sub-visor 300, which is the top-bottom direction in the illustrated embodiment.

[0111] In other words, the horizontal cross-section of the sub-body 310 has an arc shape whose center is located in the receiving space 110 and extends in the width direction of the receiving space 110, that is, in the left-right direction. In this case, the sub-body 310 is formed such that the height direction, that is, the width in the top-bottom direction, of the receiving space 110 is reduced along a direction toward the ends in the extension direction, that is, the ends in the left-right direction. Accordingly, it will be understood that the sub-body 310 has a curved shape extending along both the height and width directions of the receiving space 110.

[0112] In this case, the height of the sub-body 310 may be less than or equal to the height of the second part 212 of the main visor 200. Accordingly, at the first position (P1), the sub-body 310 overlaps the second part 212 such that the area exposed to the outside may be minimized.

[0113] The sub-protrusion 320 is coupled to or spaced apart from the main support protrusion 230 of the main visor 200 as the sub-visor 300 rotates. Due to the coupling and separation, the rotation distance of the sub-visor 300 may be limited.

[0114] The sub-protrusion 320 is formed on the sub-body 310. Specifically, the sub-protrusion 320 is formed to protrude from one surface among the surfaces of the sub-body 310 facing the second part 212 of the main visor 200, or a front side surface in the illustrated embodiment.

[0115] The sub-protrusion 320 may extend a predetermined length in the width direction of the sub-body 310, which is the left-right direction in the illustrated embodiment. Accordingly, the sub-protrusion 320 is formed to have an arc-shaped cross-section whose center is located in the receiving space 110.

[0116] A plurality of sub-protrusions 320 may be formed. The plurality of sub-protrusions 320 may be arranged to be spaced apart from each other along the height direction of the sub-body 310, that is, in the top-bottom direction in the illustrated embodiment. At the first position (P1), any one sub-protrusion 320 among the plurality of sub-protrusions 320 may be positioned adjacent to the main support protrusion 230. At the second position (P2), another sub-protrusion 320 of the plurality of sub-protrusions 320 may be positioned adjacent to the main support protrusion 230.

[0117] The sub-protrusion 320 may contact or be spaced apart from the main support protrusion 230 as the sub-visor 300 moves. As will be described below, a plurality of sub-protrusions 320 may be provided, and by the movement of the sub-visor 300, it will be understood that any one of the plurality of sub-protrusions 320 may be spaced apart from the main support protrusion 230.

[0118] In the illustrated embodiment, the sub-protrusion 320 includes a first sub-protrusion 321 located at one end in the height direction of the sub-body 310, that is, the upper end, and a second sub-protrusion 322 located at the other end, that is, the lower end.

[0119] The first sub-protrusion 321 is located on the upper side of the sub-body 310 and is spaced apart from the main support protrusion 230 at the first position (P1). Additionally, when the sub-visor 300 is rotated downward to form the second position (P2), the first sub-protrusion 321 comes into contact with the main support protrusion 230. Accordingly, the downward movement distance of the sub-visor 300 is limited. As a result, the area of the sub-visor 300 exposed to the outside of the main visor 200 may be limited.

[0120] A plurality of first sub-protrusions 321 may be formed. The plurality of first sub-protrusions 321 may be spaced apart from each other, and a space may be formed therebetween. In the illustrated embodiment, a pair of first sub-protrusions 321 are provided, and the pair of first sub-protrusions 321 are arranged to be spaced apart from each other along the height direction, that is, the top-bottom direction, of the sub-body 310.

[0121] At the second position (P2), the main support protrusion 230 is inserted into a space formed between the pair of first sub-protrusions 321. Accordingly, additional movement downward of the sub-visor 300 may be limited.

[0122] The second sub-protrusion 322 is located on the lower side of the sub-body 310 and comes into contact with the main support protrusion 230 at the first position (P1). Accordingly, the upward movement distance of the sub-visor 300 is limited. As a result, the area where the sub-visor 300 overlaps the main visor 200 may be limited. Additionally, when the sub-visor 300 is rotated downward to form the second position (P2), the second sub-protrusion 322 is spaced apart from the main support protrusion 230 and is exposed to the outside of the main visor 200.

[0123] The second sub-protrusion 322 is disposed adjacent to the grasping protrusion 340. In this case, the second sub-protrusion 322 is spaced apart from the grasping protrusion 340 by a predetermined distance, and a space is formed therebetween. At the first position (P1), the main support protrusion 230 may be inserted into the space.

[0124] In this case, the above-described first sub-protrusion 321 and second sub-protrusion 322 may partially overlap with the main support protrusion 230 along the movement direction of the sub-visor 300. Accordingly, contact and separation between the first sub-protrusion 321 and the second sub-protrusion 322 and the main support protrusion 230 may be performed in the form of fitting and removal.

[0125] As a result, unless the wearer applies an external force of a predetermined size or greater, the first sub-protrusion 321 and the second sub-protrusion 322 are not arbitrarily spaced apart from the main support protrusion 230. Accordingly, the relative positions of the sub-visor 300 and the main visor 200 may be maintained stably.

[0126] The sub-coupling part 330 is a portion where the sub-visor 300 is coupled to the visor coupler 400 and the main visor 200 through the visor coupler 400.

[0127] The sub-coupling part 330 may be formed at a corner of the sub-body 310 facing the visor coupler 400. In the embodiment illustrated in FIG. 5, the sub-coupling part 330 is located adjacent to an end in the width direction. In other words, the sub-coupling part 330 is located adjacent to one end facing the visor coupler 400.

[0128] A plurality of sub-coupling parts 330 may be formed. Each of the plurality of sub-coupling parts 330 may be coupled to a different visor coupler 400. In the illustrated embodiment, the sub-coupling parts 330 are located at the left end and right end of the sub-body 310, respectively.

[0129] In the illustrated embodiment, the sub-coupling part 330 includes a sub-edge 331 and a sub-coupling hole 332.

[0130] The sub-edge 331 forms part of the edge of sub-body 310. The sub-edge 331 may be defined as an edge facing a limiting edge 430 of the visor coupler 400. The sub-edge 331 is in contact with or spaced apart from the limiting edge 430 of the visor coupler 400 as the sub-visor 300 rotates.

[0131] Specifically, at the first position (P1), the sub-edge 331 is spaced apart from the limiting edge 430. At the second position (P2), the sub-edge 331 is in contact with the limiting edge 430. As will be described below, the visor coupler 400 and the main visor 200 are coupled such that relative movement is limited.

[0132] Accordingly, as the sub-visor 300 is rotated relative to the main visor 200, the sub-visor 300 is also rotated relative to the visor coupler 400. In this case, the sub-edge 331 may be in contact with the limiting edge 430, thereby limiting the rotation distance or rotation angle of the sub-visor 300.

[0133] The sub-coupling hole 332 is a portion where the sub-visor 300 is rotatably coupled to the visor coupler 400. The sub-coupling hole 332 is formed through the sub-body 310 such that the sub-coupling protrusion 420 of the visor coupler 400 may be coupled thereto.

[0134] The sub-coupling hole 332 may be any structure that is capable of rotatably coupling the sub-visor 300 and the visor coupler 400. In the illustrated embodiment, the sub-coupling hole 332 is formed to have a circular cross-section.

[0135] The grasping protrusion 340 is a portion that is exposed to the outside and manipulated by the wearer. The grasping protrusion 340 is exposed to the outside of the main visor 200 regardless of the first position (P1) or the second position (P2). Accordingly, the wearer may rotate the sub-visor 300 regardless of the position of the sub-visor 300.

[0136] The grasping protrusion 340 is continuous with the other end in the height direction of the sub-body 310, which is the lower end in the illustrated embodiment. In other words, the grasping protrusion 340 forms the lower end of the sub-visor 300.

[0137] The grasping protrusion 340 extends obliquely at a predetermined angle with the sub-body 310. Specifically, the grasping protrusion 340 extends obliquely along a direction in which the sub-body 310 extends, which is the top-bottom direction in the illustrated embodiment. That is, with further reference to FIGS. 7 and 8, the grasping protrusion 340 extends obliquely toward the front lower side. In other words, the grasping protrusion 340 extends from one end in the height direction of the sub-body 310, which is the lower end in the illustrated embodiment, away from the main support protrusion 230.

[0138] In this case, one end of the grasping protrusion 340 in the extension direction may be disposed to protrude compared to the other surface of the main body 210 opposite to the receiving space 110, which is the front side surface in the illustrated embodiment. Accordingly, the wearer may easily recognize the position of the grasping protrusion 340 through the sense of touch without visual identification, and rotate the sub-visor 300 by manipulating the grasping protrusion 340.

[0139] As will be described below, at the first position (P1), the other end of the grasping protrusion 340 in the extension

direction may be in contact with the main support protrusion 230. Due to the contact, the movement distance in a direction in which the sub-visor 300 overlaps the main visor 200 may be limited.

[0140] The grasping protrusion 340 and the second sub-protrusion 322 are spaced apart from each other, and a space is formed therebetween. At the first position (P1), the main support protrusion 230 may be inserted into a space formed between the grasping protrusion 340 and the second sub-protrusion 322.

[0141] Referring again to FIG. 3, the head protection device 10 according to an embodiment of the present invention includes a visor coupler 400.

[0142] The visor coupler 400 rotatably supports the sub-visor 300. Additionally, the visor coupler 400 is coupled to the main visor 200. Accordingly, it can be said that the visor coupler 400 rotatably couples the sub-visor 300 to the main visor 200.

[0143] The visor coupler 400 is coupled to the main visor 200. Specifically, the visor coupler 400 is inserted and coupled to the main coupling groove 220 of the main visor 200. As described above, the main coupling groove 220 includes a first main coupling groove 221 and a second main coupling groove 222 extending in different directions. Accordingly, the visor coupler 400 and the main visor 200 may be coupled with limited relative rotation.

[0144] The visor coupler 400 is coupled to the sub-visor 300. Specifically, the visor coupler 400 is rotatably coupled to the sub-coupling part 330 of the sub-visor 300. In this case, as described above, the rotation distance of the sub-visor 300 is limited by the visor coupler 400.

[0145] A plurality of visor couplers 400 may be provided. The plurality of visor couplers 400 may be respectively coupled to a plurality of main coupling grooves 220 and a plurality of sub-coupling parts 330. In the illustrated embodiment, two visor couplers 400 are provided and are coupled to the main coupling groove 220 and the sub-coupling part 330 located on the left and right sides, respectively.

[0146] In the illustrated embodiment, the visor coupler 400 is illustrated to be separately provided and coupled to the main visor 200. Alternatively, the visor coupler 400 may be formed to be coupled to the main visor 200. That is, the visor coupler 400 may be formed integrally with the main visor 200.

[0147] In the embodiment illustrated in FIG. 6, the visor coupler 400 includes a main coupling protrusion 410, a sub-coupling protrusion 420 and a limiting edge 430.

[0148] The main coupling protrusion 410 is a portion where the visor coupler 400 is coupled to the main visor 200. The main coupling protrusion 410 is formed to protrude inward in a direction toward the main visor 200, which is the inner side in the illustrated embodiment.

[0149] The main coupling protrusion 410 is coupled to the main coupling groove 220. Specifically, the main coupling protrusion 410 is inserted and coupled to the main coupling groove 220. To this end, the main coupling protrusion 410 may be formed in a shape corresponding to the main coupling groove 220.

[0150] As described above, since the main coupling groove 220 extends obliquely with respect to the edge of the main body 210, the main coupling protrusion 410 may also extend obliquely along the extension direction of the main coupling groove 220.

[0151] A plurality of main coupling protrusions 410 may be provided. The plurality of main coupling protrusions 410 may extend in different directions, be spaced apart from each other, and be coupled to the plurality of main coupling grooves 220, respectively. In the illustrated embodiment, two main coupling grooves 220 are provided, and are inserted and coupled to the first main coupling groove 221 and the second main coupling groove 222, respectively.

[0152] The sub-coupling protrusion 420 is a portion where the sub-visor 300 is rotatably coupled to the visor coupler 400. The sub-coupling protrusion 420 is formed to protrude in a direction toward the sub-visor 300, which is toward the inner side in the illustrated embodiment.

[0153] The sub-coupling protrusion 420 is coupled to the sub-coupling hole 332. Specifically, the sub-coupling protrusion 420 is coupled through the sub-coupling hole 332. The sub-coupling protrusion 420 may be formed in a shape corresponding to the sub-coupling hole 332. In the illustrated embodiment, the sub-coupling protrusion 420 has the same shape as the sub-coupling hole 332, that is, a cylindrical shape with a circular cross-section and extending toward the sub-visor 300.

[0154] The sub-coupling protrusion 420 is coupled to the main coupling hole (reference numeral not assigned) described above. In this case, as described above, the main coupling protrusion 410 is coupled to the main coupling groove 220 such that relative rotation of the visor coupler 400 and the main visor 200 may be prevented. Accordingly, the sub-coupling protrusion 420 is relatively fixed to the main visor 200 and may rotatably support the sub-visor 300.

[0155] The limiting edge 430 is in contact with or spaced apart from the sub-edge 331 as the sub-visor 300 rotates. Due to the contact between the limiting edge 430 and the sub-edge 331, the downward rotation distance or rotation angle of the sub-visor 300 may be limited.

[0156] The limiting edge 430 forms one edge of visor coupler 400. That is, in the embodiment illustrated in FIG. 6, the limiting edge 430 forms an edge in a direction facing the sub-edge 331 of the sub-visor 300.

[0157] The limiting edge 430 may extend obliquely. Specifically, the limiting edge 430 may extend parallel to the sub-edge 331, when the sub-visor 300 is rotated to the second position (P2). Accordingly, the limiting edge 430 may stably

support the sub-edge 331 to limit the rotation distance of the sub-visor 300.

[0158] Hereinafter, the operation process of a head protection device 10 according to an embodiment of the present invention will be described in detail with reference to FIGS. 7 and 8.

[0159] Referring to FIG. 7, a state in which the sub-visor 300 is located at the first position (P1) is illustrated. At the first position (P1), the area of the sub-visor 300 exposed to the outside is minimized. Accordingly, the area where the sub-visor 300 overlaps the main visor 200, specifically the second part 212, at the first position (P1) is maximized.

[0160] Referring to the enlarged view of FIG. 7, the upper first sub-protrusion 321 is spaced apart from the main support protrusion 230 and is located adjacent to the upper end of the second part 212. In addition, the main support protrusion 230 is fitted into a space formed between the lower second sub-protrusion 322 and the grasping protrusion 340.

[0161] In the above state, the sub-edge 331 and the limiting edge 430 are spaced apart from each other such that it will be understood that a clearance is formed that allows the sub-visor 300 to be moved in a direction opposite to the main visor 200, that is, downward in the illustrated embodiment.

[0162] Referring to FIG. 8, a state in which the sub-visor 300 is located at the second position (P2) is illustrated. At the second position (P2), the area of the sub-visor 300 exposed to the outside is maximized. Accordingly, the area where the sub-visor 300 overlaps the main visor 200, specifically the second part 212, at the second position (P2) is minimized.

[0163] Referring to the enlarged view of FIG. 8, the upper first sub-protrusion 321 is located adjacent to the main support protrusion 230. As described above, in an embodiment where a pair of first sub-protrusions 321 are provided, the main support protrusion 230 is fitted into a space formed by the pair of first sub-protrusions 321 that are spaced apart from each other.

[0164] In the above state, the sub-edge 331 and the limiting edge 430 are in contact with each other, thereby preventing the sub-visor 300 from moving further downward.

[0165] Hereinafter, with reference to FIGS. 9 and 10, the flow (F) of outside air formed by a head protection device 10 according to an embodiment of the present invention will be described in detail.

[0166] Referring to FIG. 9, a state in which the sub-visor 300 is located at the first position (P1) is illustrated. At the first position (P1), the exposed area of the sub-visor 300 is minimized, and most of the outside air flows after colliding with the main visor 200.

[0167] At the first position (P1), the flow (F) of outside air in the lower portions of the main visor 200 and the sub-visor 300 is described as follows.

[0168] The outside air on the front side flows downward along the main visor 200. In this case, the sub-visor 300 is located at the first position (P1), and thus, the area exposed to the outside is minimized.

[0169] The flow (F) of outside air passes through the grasping protrusion 340 located at the lower end of the sub-visor 300 and proceeds toward the back side. Some of the flow (F) of outside air passing through the sub-visor 300 proceeds toward the upper side on the back side.

[0170] In this case, since the grasping protrusion 340 is located adjacent to the main visor 200, the part of the flow (F) of outside air flows to the lower side where the receiving space 110 is opened.

[0171] Accordingly, part of the outside air may flow into the receiving space 110, thereby causing driving noise. Furthermore, part of the outside air flowing into the receiving space 110 may flow into the wearer's eyes, thereby causing eye irritation.

[0172] Referring to FIG. 10, a state in which the sub-visor 300 is located at the second position (P2) is illustrated. At the second position (P2), the exposed area of the sub-visor 300 is maximized, and part of the outside air flows after colliding with the main visor 200 and the other part of the outside air flows after colliding with the sub-visor 300.

[0173] At the second position (P2), the flow (F) of outside air in the lower portions of the main visor 200 and the sub-visor 300 is described as follows.

[0174] The outside air on the front side flows downward along the main visor 200. In this case, the sub-visor 300 is located at the second position (P2), and thus, the area exposed to the outside is maximized.

[0175] The flow (F) of the outside air passes through the grasping protrusion 340 located at the lower end of the sub-visor 300 and proceeds toward the back side. Part of the flow (F) of the outside air passing through the sub-visor 300 proceeds toward the upper side on the back side.

[0176] In this case, the grasping protrusion 340 is positioned to be spaced apart from the main visor 200 as much as possible. Accordingly, the distance that must travel for the part of the flow (F) of outside air to extend into the receiving space 110 increases. As the distance increases, the resistance to the flow (F) of the outside air moving toward the receiving space 110 increases such that most of the outside air does not enter the receiving space 110.

[0177] As a result, the amount of outside air flowing into the receiving space 110 may be minimized, thereby minimizing driving noise and eye irritation caused by the inflow of outside air.

[0178] As described above, the head protection device 10 according to an embodiment of the present invention includes a main visor 200 and a sub-visor 300 which is rotatably coupled to the main visor 200. The sub-visor 300 may be arranged to overlap the main visor 200 by external manipulation, or may be arranged to be exposed from the main visor 200 such that the overall area of the visor may be varied.

[0179] When the sub-visor 300 is maintained at the second position (P2), that is, the area exposed to the outside is maintained to be maximal, the flow rate of outside air flowing upward among the outside air flowing toward the back side along the main visor 200 and the sub-visor 300 may be minimized.

[0180] Accordingly, the amount of outside air flowing into the interior of the head protection device 10, that is, the receiving space 110, may also be minimized, and the driving noise generated by the introduced outside air may be minimized. In addition, the amount of outside air flowing into the user's eyes is also minimized, thereby preventing eye irritation.

[0181] As the sub-visor 300 is rotatably coupled to the main visor 200, the overall areas of the main visor 200 and the sub-visor 300 may be varied even if no separate additional member is provided.

[0182] The grasping protrusion 340 provided at the lower end of the sub-visor 300 is exposed to the outside of the main visor 200. The wearer may easily vary the overall area of the visor by rotating the grasping protrusion 340.

[0183] The sub-visor 300 is rotatably coupled to the main visor 200 by the sub-coupling protrusion 420 of the visor coupler 400. Additionally, the rotation distance or rotation angle of the sub-visor 300 is limited by the main support protrusion 230 of the main visor 200 and the limiting edge 430 of the visor coupler 400. Furthermore, the sub-visor 300 may be coupled to the main support protrusion 230 or supported on the limiting edge 430 and maintained in a rotated position.

[0184] Although the embodiments of the present invention have been described above, the spirit of the present invention is not limited to the embodiments presented in the present specification, and those skilled in the art who understand the spirit of the present invention may easily suggest other embodiments by changing, modifying, deleting or adding components within the scope of the same spirit, but this will also fall within the scope of the present invention.

| | | | |
|------|----------------------------|------|-----------------------------|
| 10: | Head protection device | 100: | Outer frame |
| 110: | Receiving space | 200: | Main visor |
| 210: | Main body | 211: | First part |
| 212: | Second part | 220: | Main coupling groove |
| 221: | First main coupling groove | 222: | Second main coupling groove |
| 230: | Main support protrusion | 240: | Main support space |
| 300: | Sub-visor | 310: | Sub-body |
| 320: | Sub-protrusion | 321: | First sub-protrusion |
| 322: | Second sub-protrusion | 330: | Sub-coupling part |
| 331: | Sub-edge | 332: | Sub-coupling hole |
| 340: | Grasping protrusion | 400: | Visor coupler |
| 410: | Main coupling protrusion | 420: | Sub-coupling protrusion |
| 430: | Limiting edge | P1: | First position |
| P2: | Second position | | |

Claims

1. A head protection device, comprising:

an outer frame having a receiving space formed therein;
 a main visor configured to cover a portion of the receiving space and rotatably coupled to the outer frame; and
 a sub-visor configured to cover another portion of the receiving space and coupled to the main visor so as to be rotatable in one direction toward the main visor and in another direction opposite thereto,
 wherein the sub-visor is rotatably configured between a first position, in which an outwardly exposed area is minimized, and a second position, in which an outwardly exposed area is maximized such that the area of the receiving space covered by the main visor and the sub-visor is adjusted.

2. The head protection device of claim 1, wherein a surface area of the sub-visor is formed to be smaller than a surface area of the main visor.

3. The head protection device of claim 1, further comprising:

a visor coupler respectively coupled to the main visor and the sub-visor, so as to rotatably support the sub-visor.

4. The head protection device of claim 3, wherein the visor coupler comprises a sub-coupling protrusion which is formed to protrude toward the sub-visor such that the sub-visor is rotatably coupled thereto.

5. The head protection device of claim 4, wherein the sub-visor comprises a sub-coupling hole which is positioned to be adjacent to one end facing the visor coupler, and is formed through an interior thereof such that the sub-coupling protrusion is rotatably coupled thereto.
- 5 6. The head protection device of claim 3 or 4, wherein the visor coupler comprises a limiting edge which forms one edge facing the sub-visor, and is configured to contact the sub-visor and limit a rotation angle of the sub-visor according to a rotation of the sub-visor.
7. The head protection device of claim 6, wherein the sub-visor comprises a sub-edge which forms one edge facing the visor coupler, and is arranged to face the limiting edge,
- 10 wherein when the sub-visor is located at the first position, the sub-edge and the limiting edge are spaced apart, and wherein when the sub-visor is located at the second position, the sub-edge and the limiting edge are configured to contact each other such that the rotation of the sub-visor is limited.
- 15 8. The head protection device of claim 1, wherein the main visor comprises a main body which extends to surround the receiving space, and extends a predetermined length along a rotational direction of the main visor.
- 20 9. The head protection device of claim 8, wherein the main body comprises:
- a first part configured to form a portion of the main body, and exclusively cover the receiving space; and a second part configured to form another portion of the main body, be continuous with the first part, and overlap the sub-visor at the first position,
- 25 wherein a thickness of the second part is formed to be less than or equal to a thickness of the first part.
10. The head protection device of claim 9, wherein the main visor comprises a main support protrusion which is formed to protrude toward the sub-visor at an end of the second part, and wherein the main support protrusion is located between an upper end of the sub-visor and a lower end of the sub-visor.
- 30 11. The head protection device of claim 10, wherein the sub-visor comprises:
- a sub-body configured to extend a predetermined length along a rotational direction of the sub-visor; and a sub-protrusion formed to extend from the sub-body toward the main visor and being in contact with or spaced apart from the main support protrusion by movement of the sub-visor.
- 35 12. The head protection device of claim 11, wherein the sub-protrusion is provided in plurality,
- wherein when the sub-visor is located at the first position, any one of a plurality of sub-protrusions is positioned to be spaced apart from the main support protrusion, and wherein when the sub-visor is located at the second position, the any one of a plurality of sub-protrusions is supported by being in contact with the main support protrusion.
- 40 13. The head protection device of claim 11, further comprising:
- 45 a grasping protrusion formed to extend in a direction away from the main support protrusion at one end of the sub-body, and having an end in the extension direction positioned on an outside of the main visor.
14. The head protection device of claim 13, wherein when the sub-visor is located at the first position, the grasping protrusion is in contact with the main support projection, and wherein when the sub-visor is located at the second position, the grasping protrusion is spaced apart from the main support protrusion.
- 50 15. The head protection device of claim 3, wherein the grasping protrusion is formed to extend obliquely at a predetermined angle with the sub-body.
- 55

[FIG. 1]

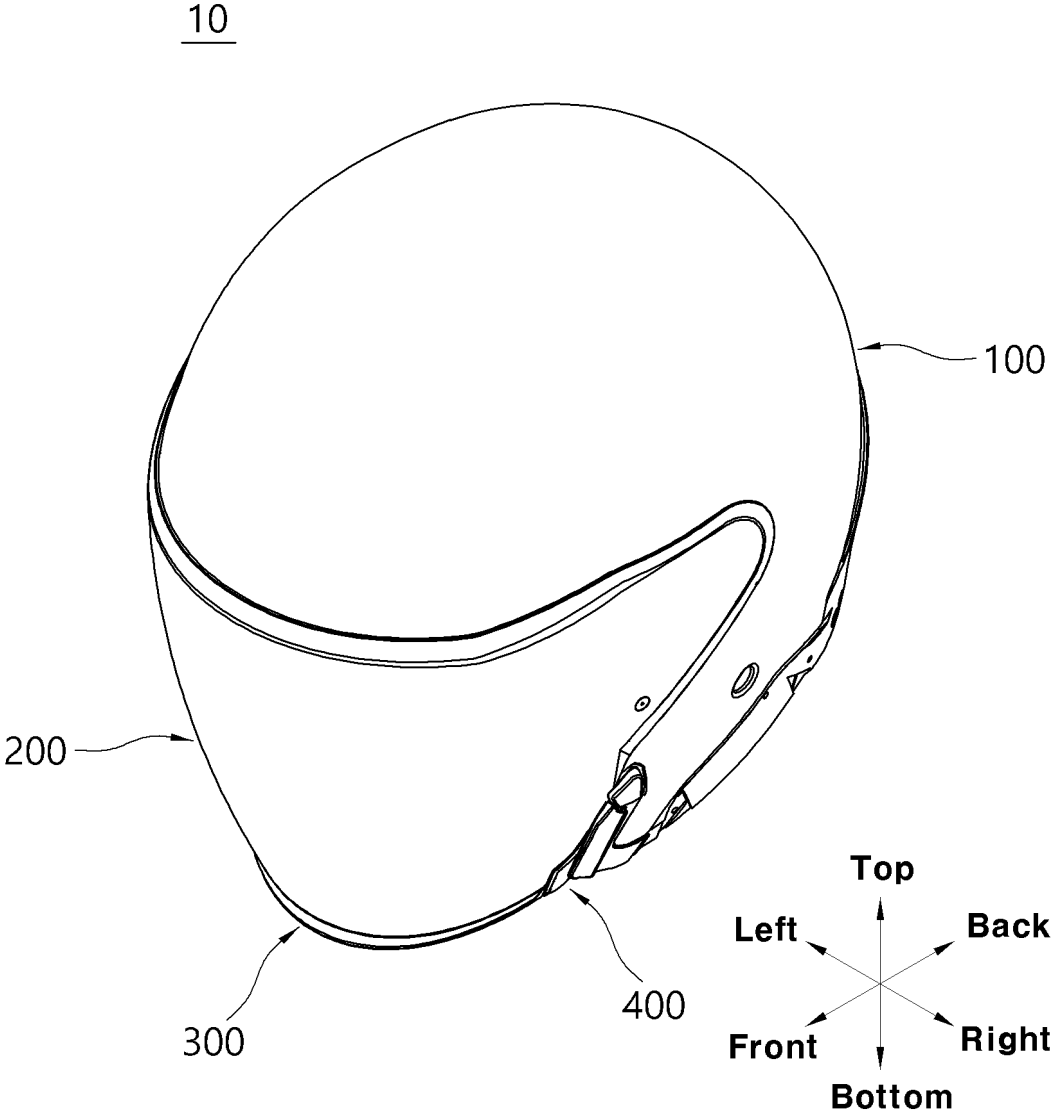

[FIG. 2]

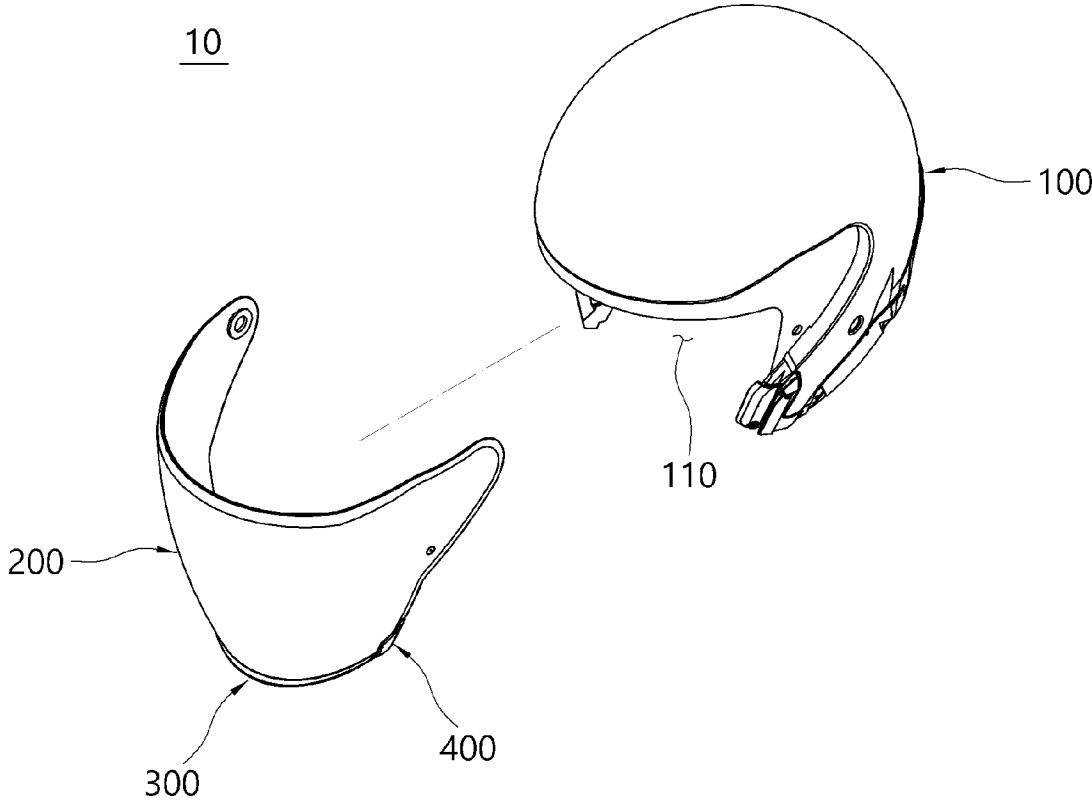

[FIG. 3]

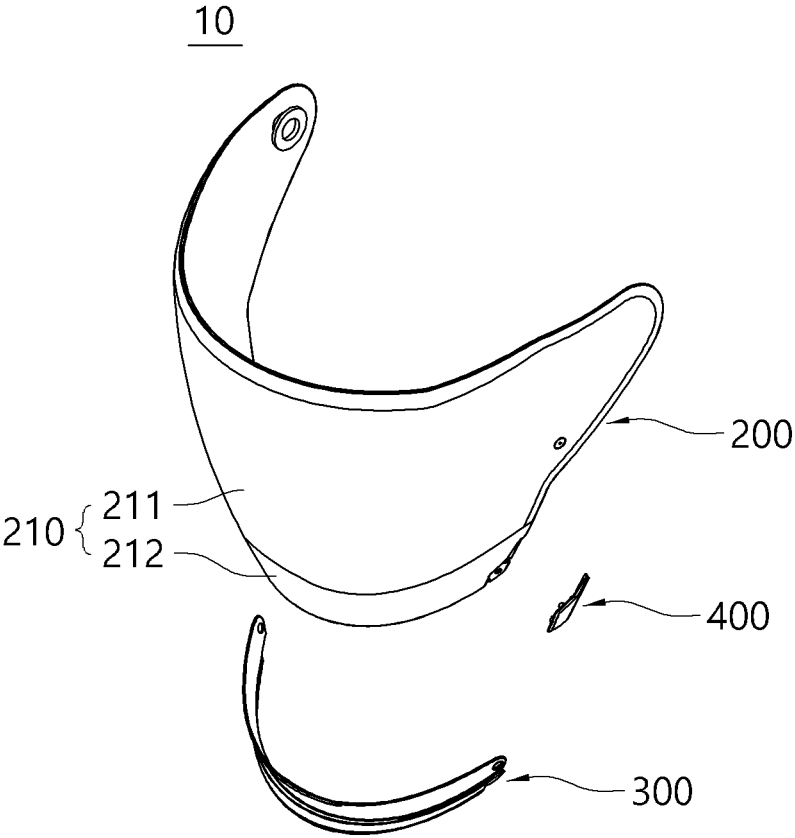

[FIG. 4]

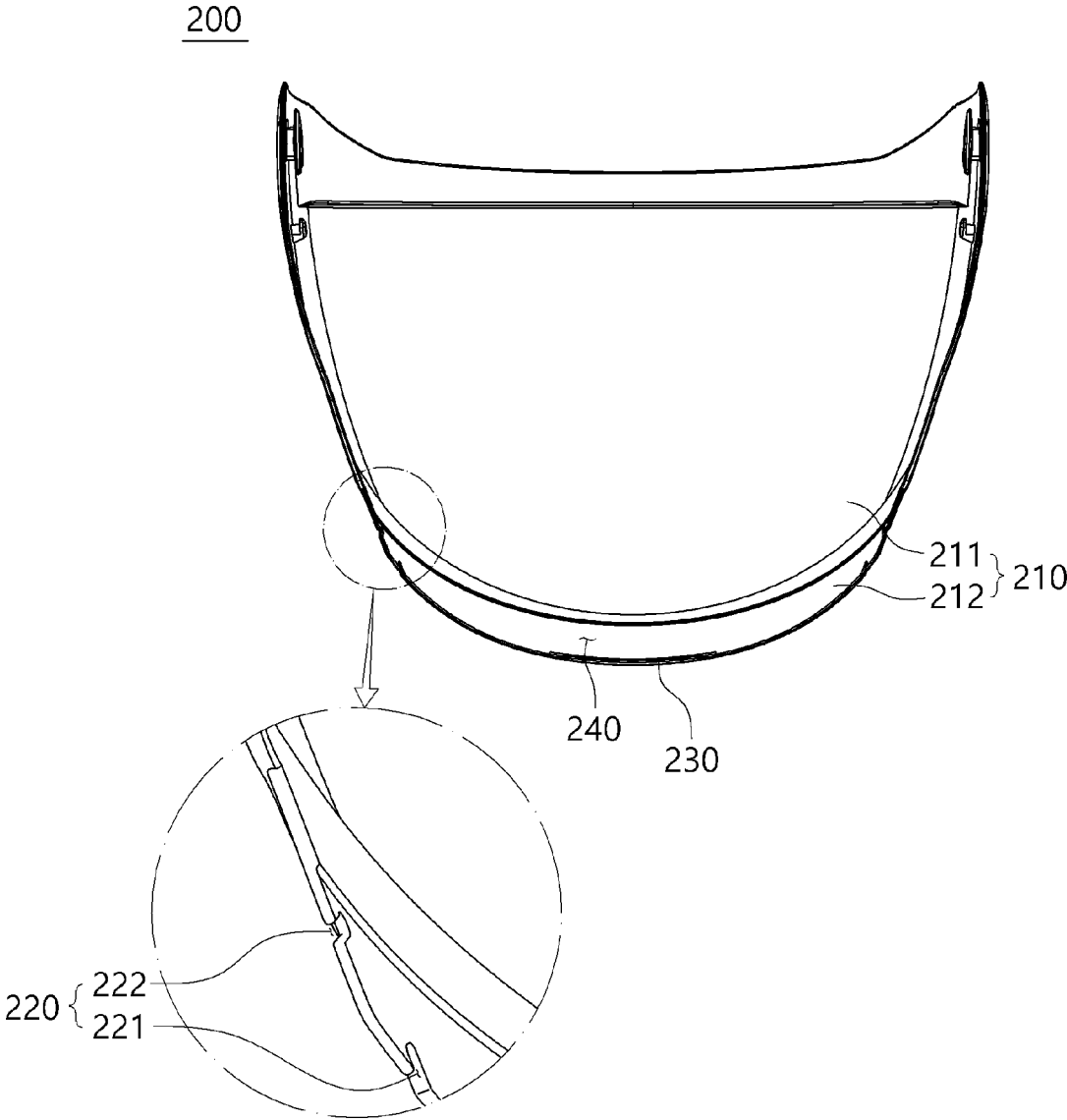

[FIG. 5]

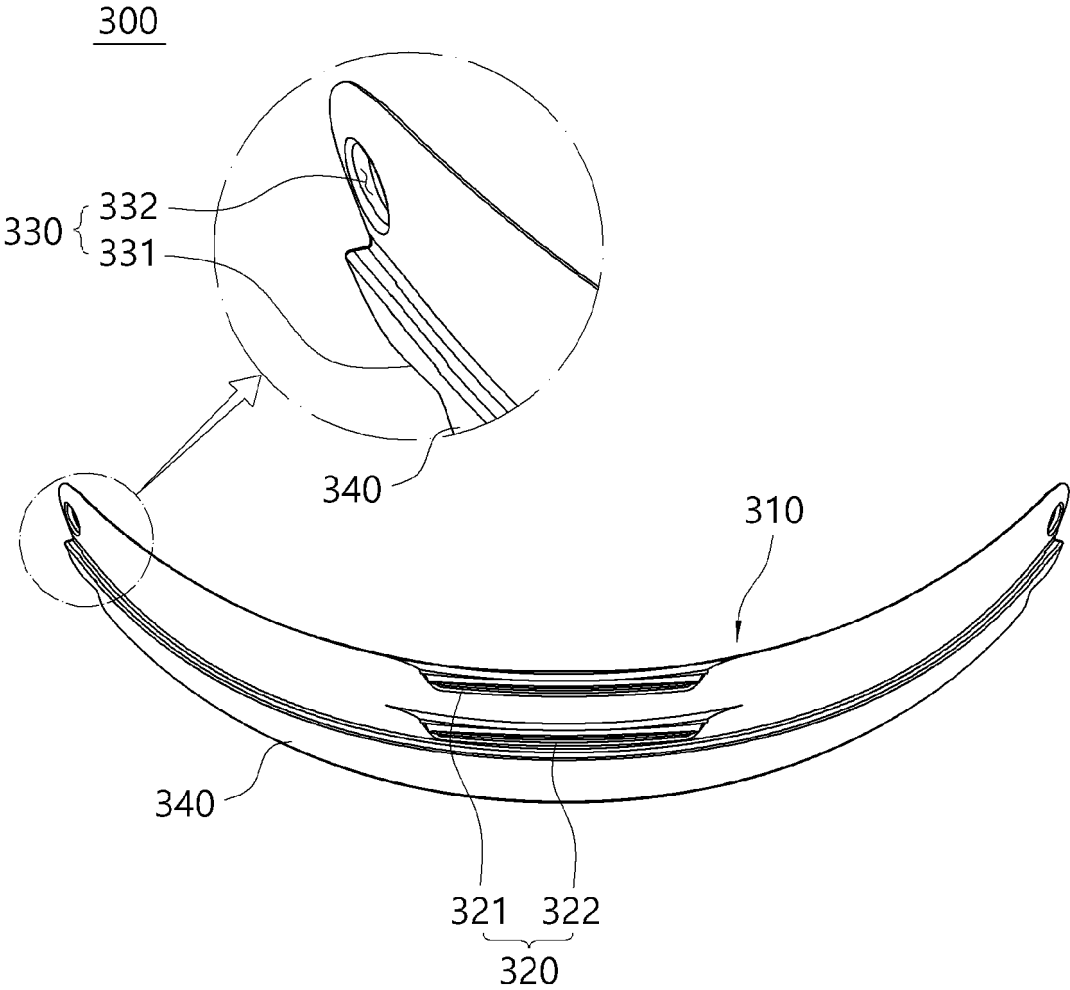

[FIG. 6]

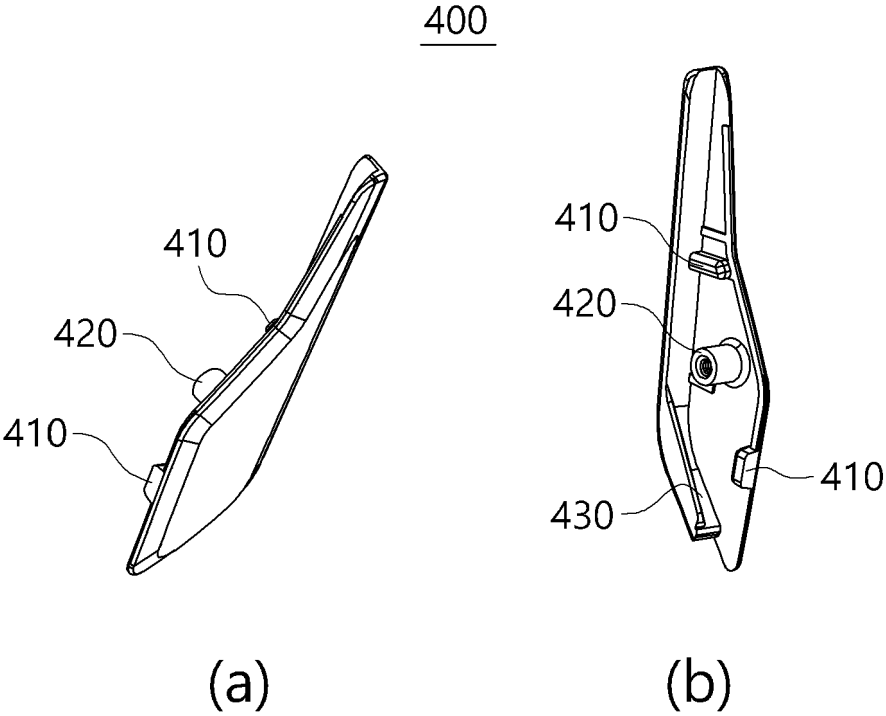

[FIG. 7]

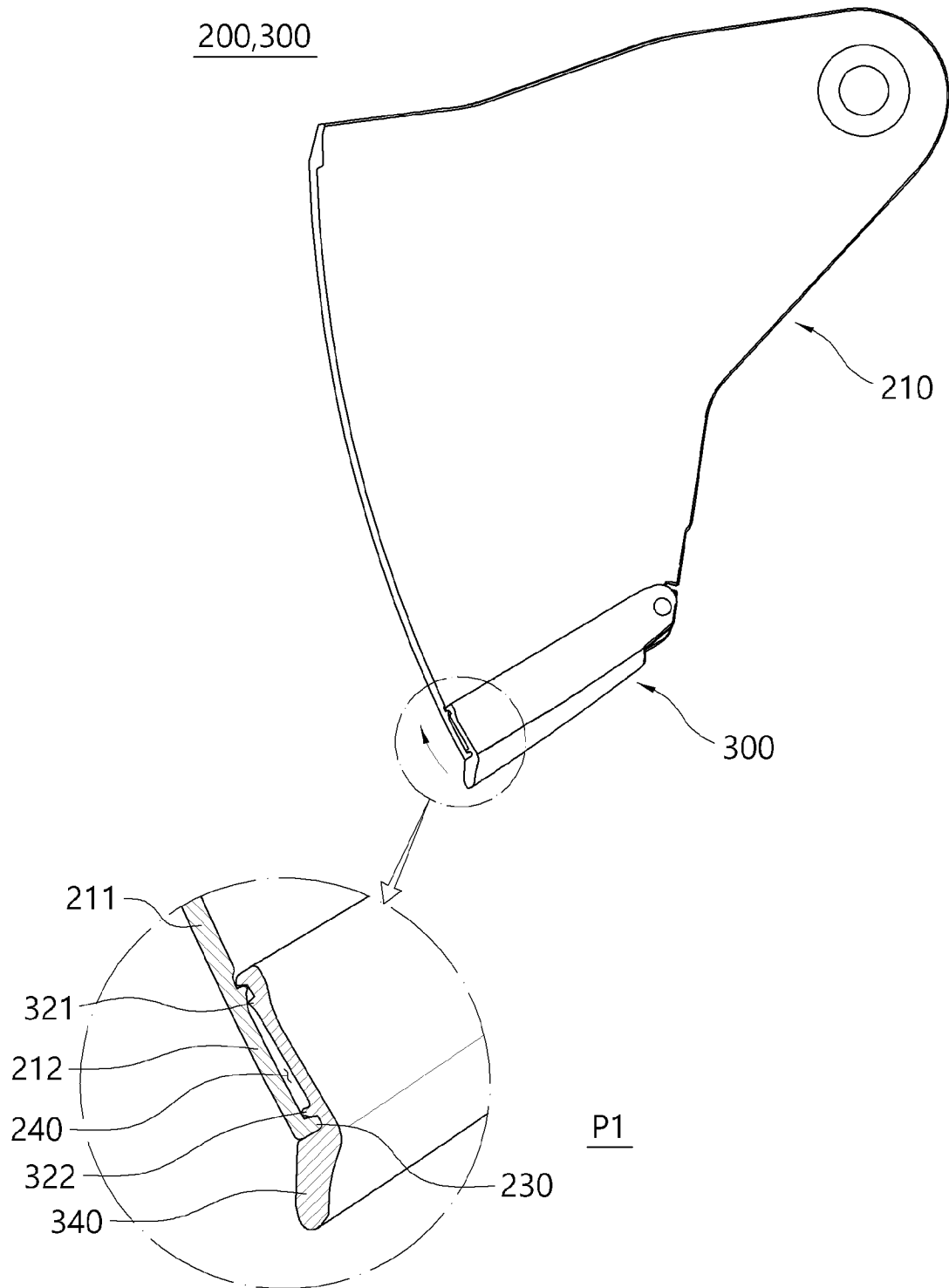

[FIG. 8]

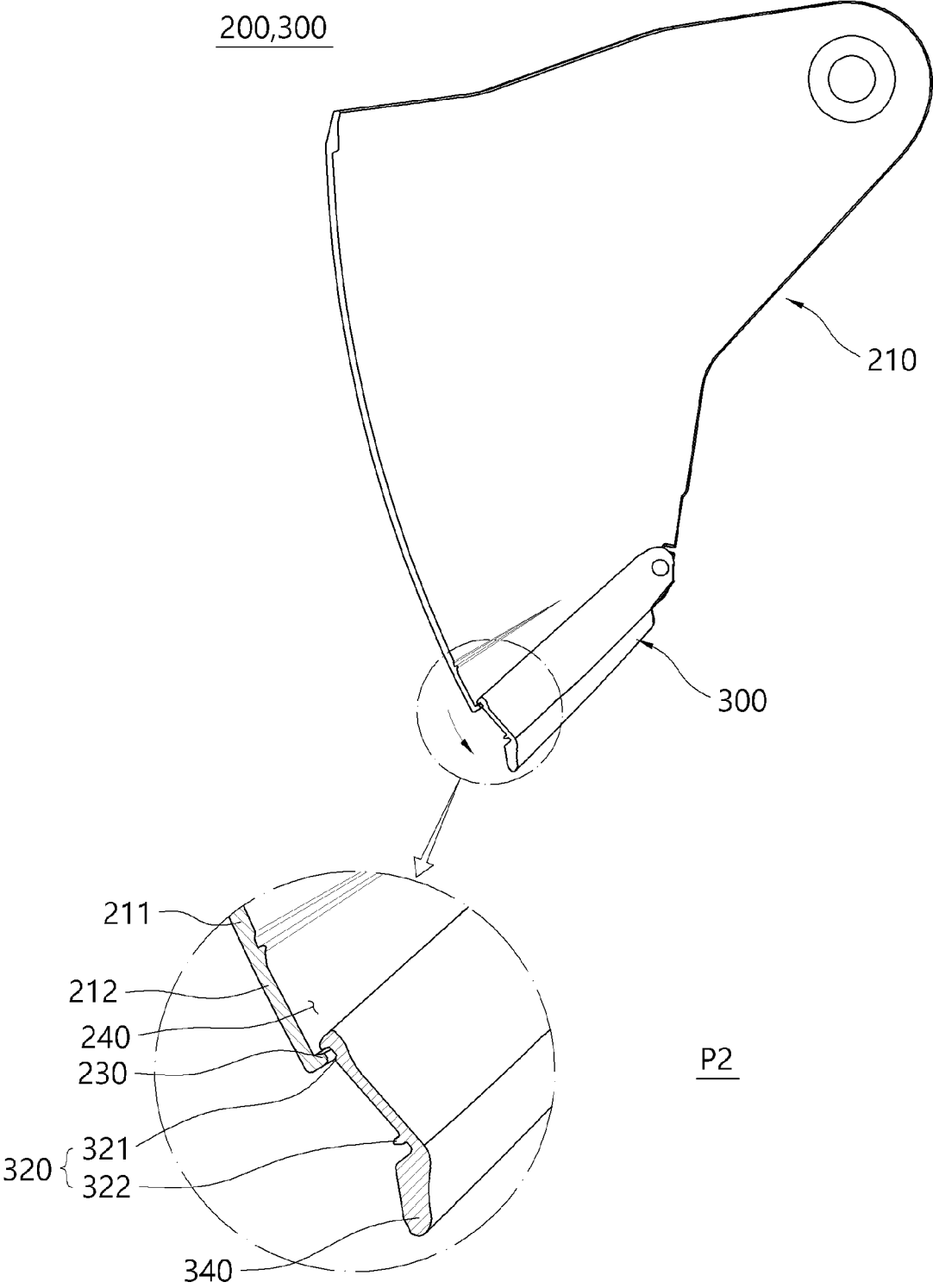

[FIG. 9]

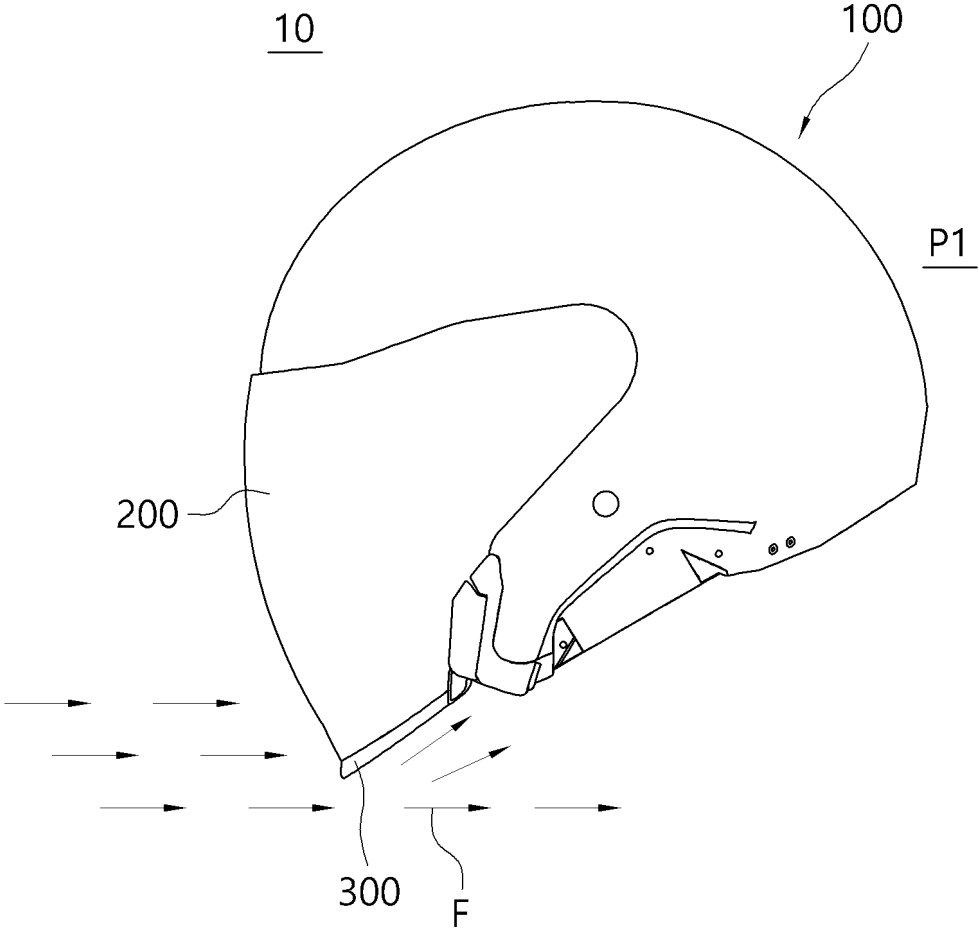

[FIG. 10]

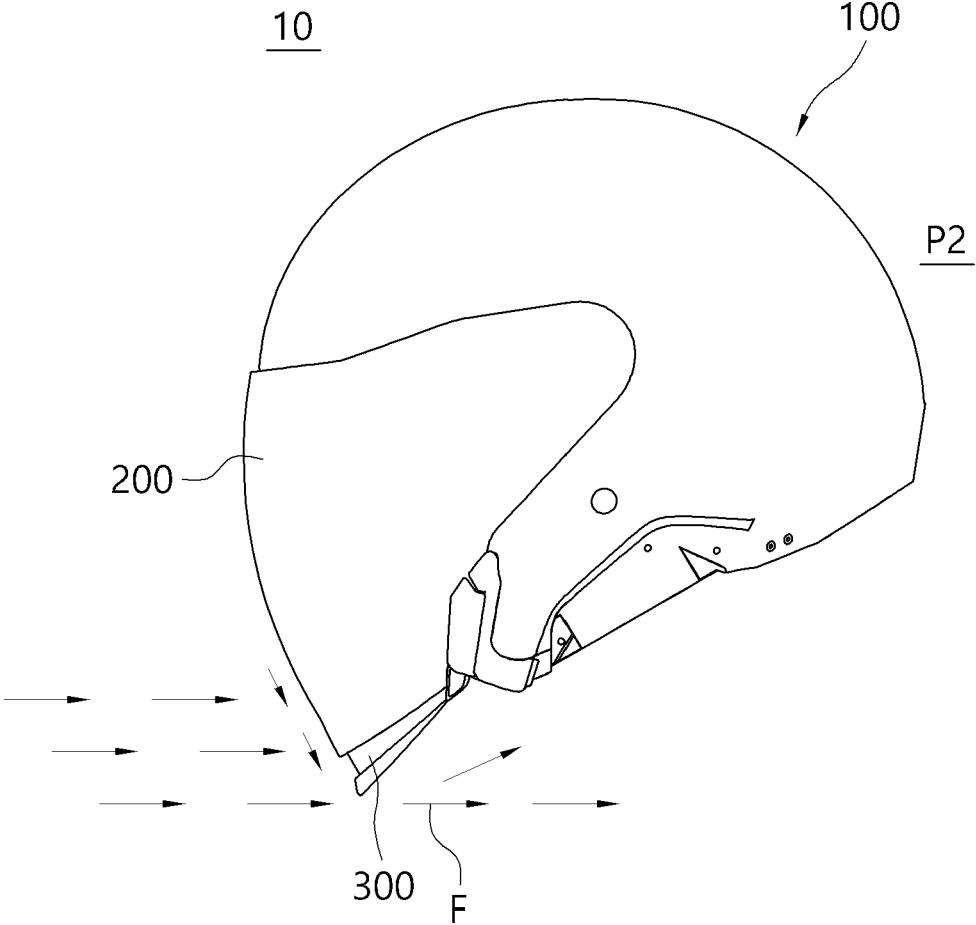

INTERNATIONAL SEARCH REPORT

International application No.

PCT/KR2023/004277

A. CLASSIFICATION OF SUBJECT MATTER
A42B 3/22(2006.01)i; A42B 3/06(2006.01)i

According to International Patent Classification (IPC) or to both national classification and IPC

B. FIELDS SEARCHED

Minimum documentation searched (classification system followed by classification symbols)
 A42B 3/22(2006.01); A42B 3/04(2006.01); A42B 3/20(2006.01)

Documentation searched other than minimum documentation to the extent that such documents are included in the fields searched
 Korean utility models and applications for utility models: IPC as above
 Japanese utility models and applications for utility models: IPC as above

Electronic data base consulted during the international search (name of data base and, where practicable, search terms used)
 eKOMPASS (KIPO internal) & keywords: 두부 (head), 보호 (protective), 바이저 (visor), 회전 (rotation), 돌기 (recess)

C. DOCUMENTS CONSIDERED TO BE RELEVANT

| Category* | Citation of document, with indication, where appropriate, of the relevant passages | Relevant to claim No. |
|-----------|---|-----------------------|
| X A | US 2012-0291185 A1 (BASSON, G.) 22 November 2012 (2012-11-22) See claims 1-3 and 18-19; and figures 2-6. | 1-7 8-15 |
| A | JP 2011-017093 A (MEIWA KOSAN KK) 27 January 2011 (2011-01-27) See entire document. | 1-15 |
| A | US 2018-0103710 A1 (KIDO SPORTS CO., LTD.) 19 April 2018 (2018-04-19) See entire document. | 1-15 |
| A | US 2004-0143888 A1 (BATAILLE, A. et al.) 29 July 2004 (2004-07-29) See entire document. | 1-15 |
| A | US 2002-0148032 A1 (BASSON, G. et al.) 17 October 2002 (2002-10-17) See entire document. | 1-15 |

Further documents are listed in the continuation of Box C. See patent family annex.

* Special categories of cited documents:
 "A" document defining the general state of the art which is not considered to be of particular relevance
 "D" document cited by the applicant in the international application
 "E" earlier application or patent but published on or after the international filing date
 "L" document which may throw doubts on priority claim(s) or which is cited to establish the publication date of another citation or other special reason (as specified)
 "O" document referring to an oral disclosure, use, exhibition or other means
 "P" document published prior to the international filing date but later than the priority date claimed
 "T" later document published after the international filing date or priority date and not in conflict with the application but cited to understand the principle or theory underlying the invention
 "X" document of particular relevance; the claimed invention cannot be considered novel or cannot be considered to involve an inventive step when the document is taken alone
 "Y" document of particular relevance; the claimed invention cannot be considered to involve an inventive step when the document is combined with one or more other such documents, such combination being obvious to a person skilled in the art
 "&" document member of the same patent family

Date of the actual completion of the international search: **30 June 2023**
 Date of mailing of the international search report: **03 July 2023**

Name and mailing address of the ISA/KR: **Korean Intellectual Property Office
 Government Complex-Daejeon Building 4, 189 Cheongsa-ro, Seo-gu, Daejeon 35208**
 Facsimile No. **+82-42-481-8578**

Authorized officer:
 Telephone No.:

INTERNATIONAL SEARCH REPORT
Information on patent family members

International application No.
PCT/KR2023/004277

5
10
15
20
25
30
35
40
45
50
55

| Patent document cited in search report | Publication date (day/month/year) | Patent family member(s) | Publication date (day/month/year) |
|--|-----------------------------------|-------------------------|-----------------------------------|
| US 2012-0291185 A1 | 22 November 2012 | CN 102791157 A | 21 November 2012 |
| | | CN 102791157 B | 02 March 2016 |
| | | EP 2536305 A1 | 26 December 2012 |
| | | EP 2536305 B1 | 13 November 2013 |
| | | US 9456649 B2 | 04 October 2016 |
| | | WO 2011-101722 A1 | 25 August 2011 |
| JP 2011-017093 A | 27 January 2011 | None | |
| US 2018-0103710 A1 | 19 April 2018 | US 10869521 B2 | 22 December 2020 |
| US 2004-0143888 A1 | 29 July 2004 | EP 1345505 A1 | 24 September 2003 |
| | | EP 1345505 B1 | 09 November 2005 |
| | | US 6820285 B2 | 23 November 2004 |
| | | WO 02-47503 A1 | 20 June 2002 |
| US 2002-0148032 A1 | 17 October 2002 | EP 1283684 A1 | 19 February 2003 |
| | | EP 1283684 B1 | 29 August 2007 |
| | | JP 2003-533614 A | 11 November 2003 |
| | | US 6795977 B2 | 28 September 2004 |
| | | WO 01-89332 A1 | 29 November 2001 |

REFERENCES CITED IN THE DESCRIPTION

This list of references cited by the applicant is for the reader's convenience only. It does not form part of the European patent document. Even though great care has been taken in compiling the references, errors or omissions cannot be excluded and the EPO disclaims all liability in this regard.

Patent documents cited in the description

- KR 1020190014960 [0007] [0011]
- KR 1020170108413 [0009] [0011]