



US 20060276758A1

(19) **United States**

(12) **Patent Application Publication**  
**Fangrow, JR.**

(10) **Pub. No.: US 2006/0276758 A1**

(43) **Pub. Date: Dec. 7, 2006**

(54) **MEDICAL VALVE WITH POSITIVE FLOW CHARACTERISTICS**

**Publication Classification**

(76) Inventor: **Thomas F. Fangrow JR.**, Mission Viejo, CA (US)

(51) **Int. Cl.**  
*A61M 5/00* (2006.01)  
(52) **U.S. Cl.** ..... **604/247**

Correspondence Address:  
**KNOBBE MARTENS OLSON & BEAR LLP**  
**2040 MAIN STREET**  
**FOURTEENTH FLOOR**  
**IRVINE, CA 92614 (US)**

(57) **ABSTRACT**

(21) Appl. No.: **11/418,394**  
(22) Filed: **May 3, 2006**

A valve for selectively permitting a fluid flow between first and second medical implements is disclosed. The valve has a housing with an interface suitable for receiving a connector portion of a first medical device such as a catheter, and a seal made of a flexible material. The seal has a first end in fluid communication with the interface, a second end suitable for receiving the second medical device, and at least one slit in fluid communication with the first end and the second end. The slit defines a restricted fluid flow path and a relatively small interior volume when in an undisturbed state, defines an expanded fluid flow path and a larger interior volume upon the introduction of the second medical instrument into the slit, and retracts to define a restricted flow path and a small interior volume upon the withdrawal of the second medical device from the seal.

**Related U.S. Application Data**

(63) Continuation of application No. 11/157,216, filed on Jun. 20, 2005, which is a continuation of application No. 10/636,163, filed on Aug. 7, 2003, now Pat. No. 6,916,309, which is a continuation of application No. 09/614,001, filed on Jul. 11, 2000, now Pat. No. 6,695,817.

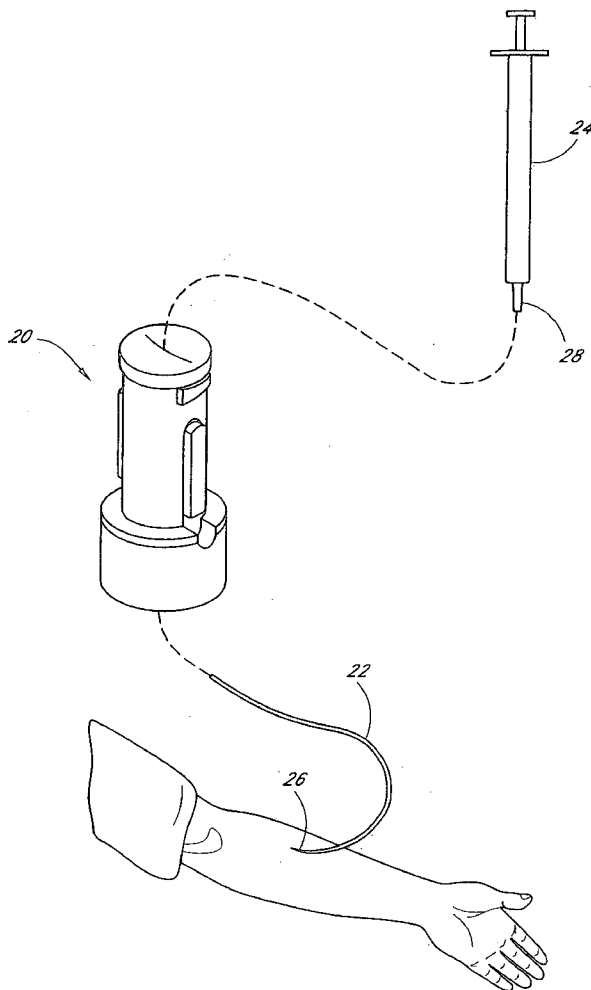

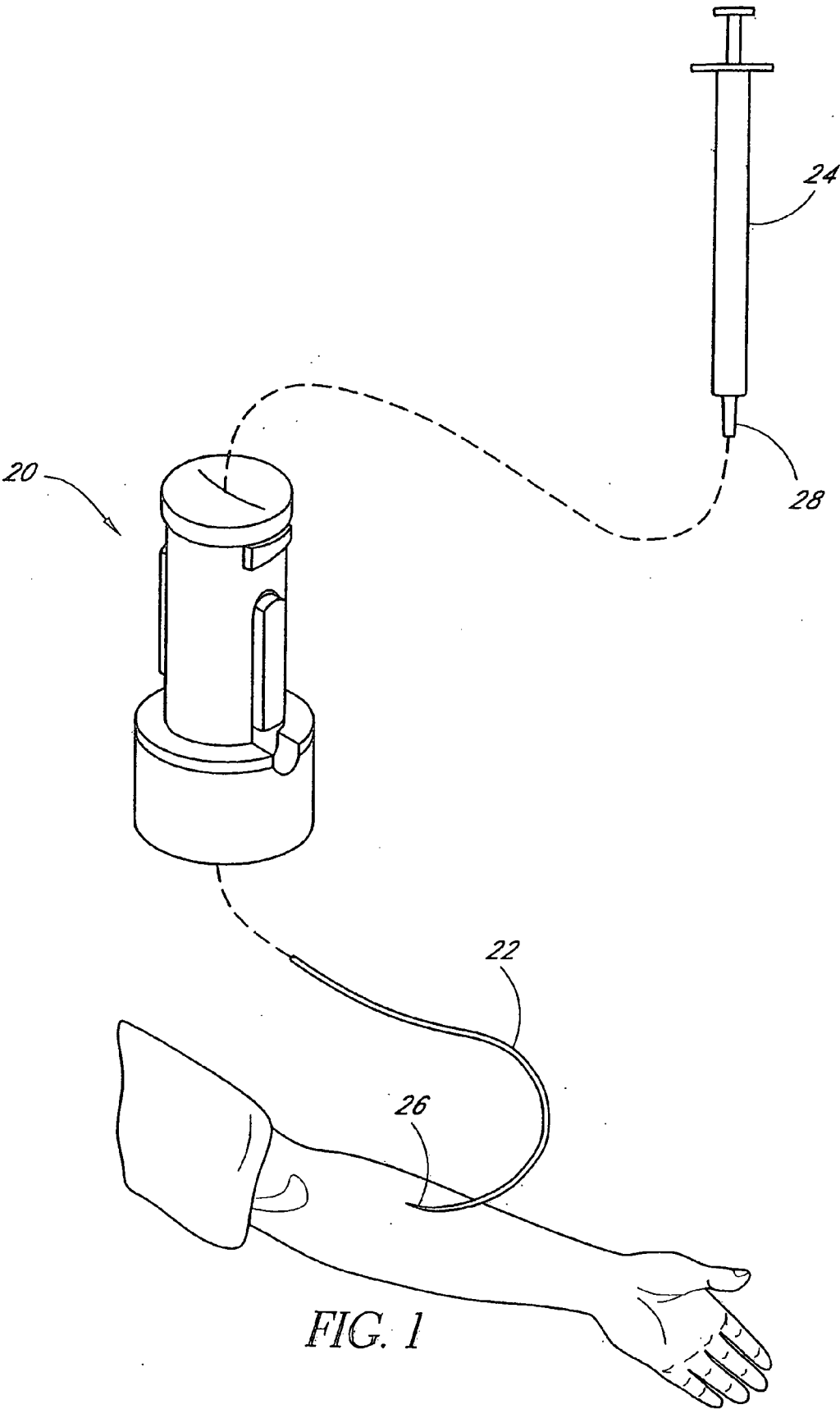

FIG. 1

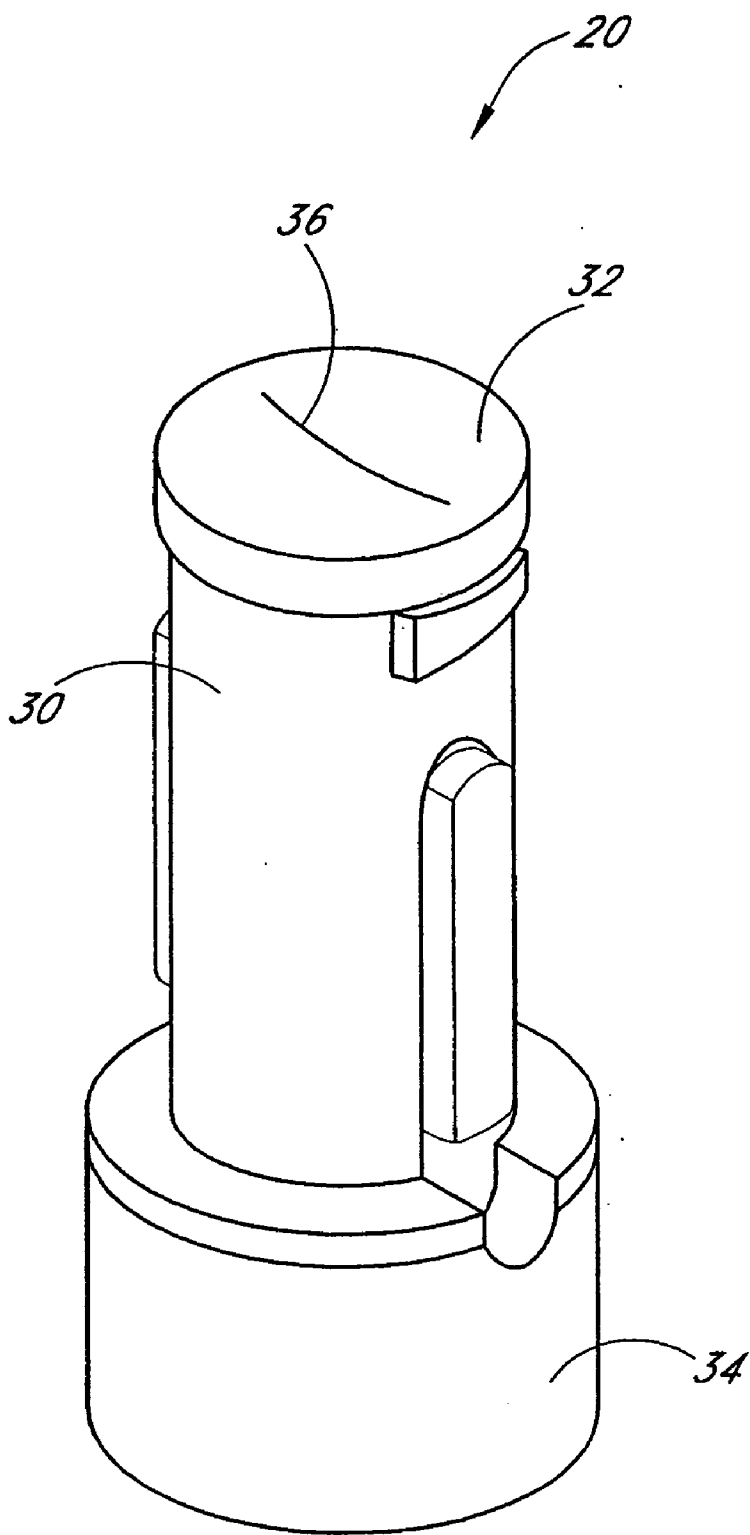

FIG. 2

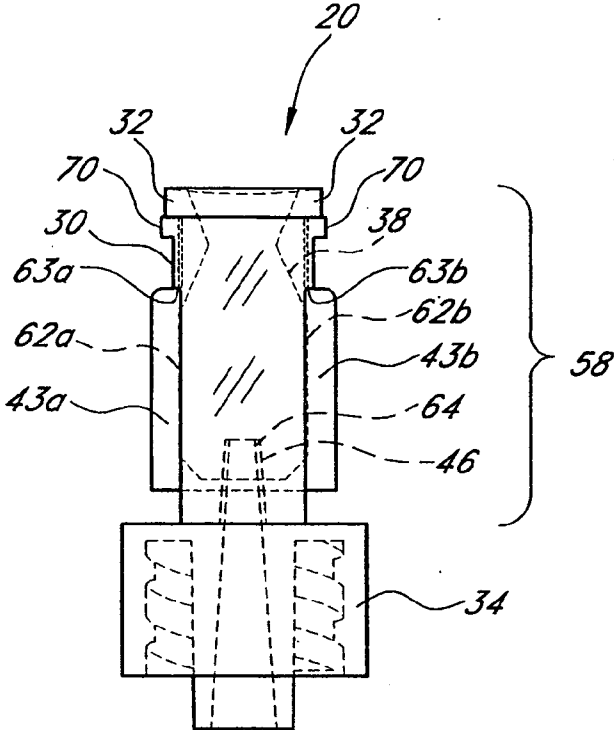

FIG. 3

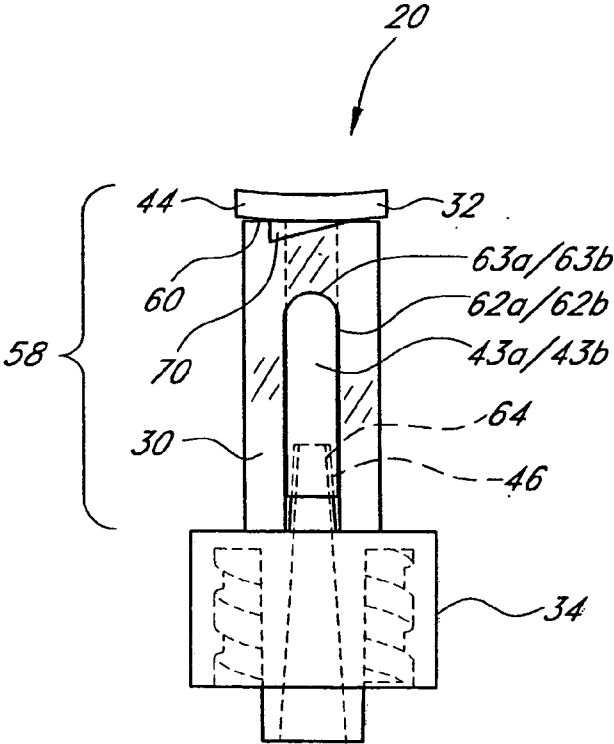

FIG. 4

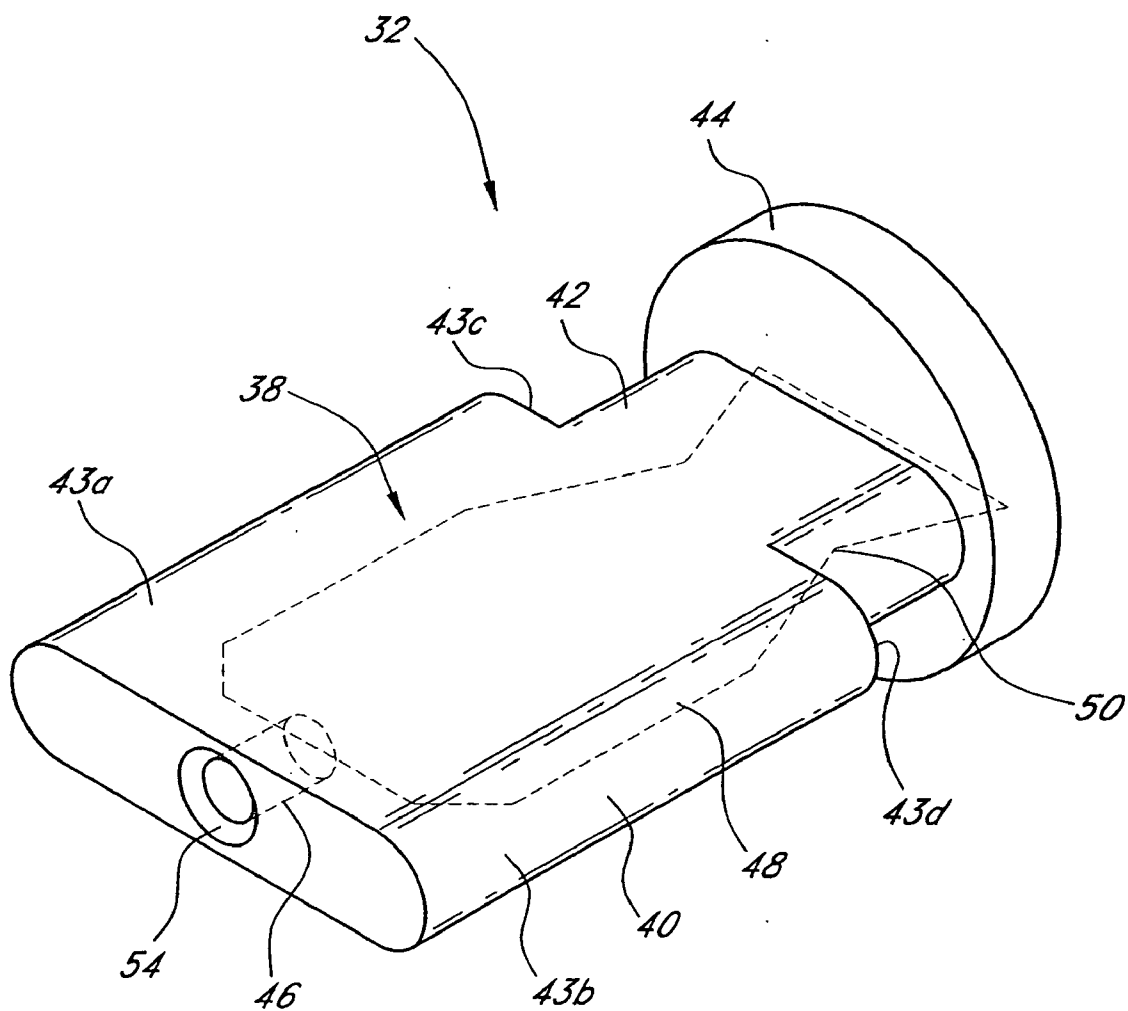

FIG. 5

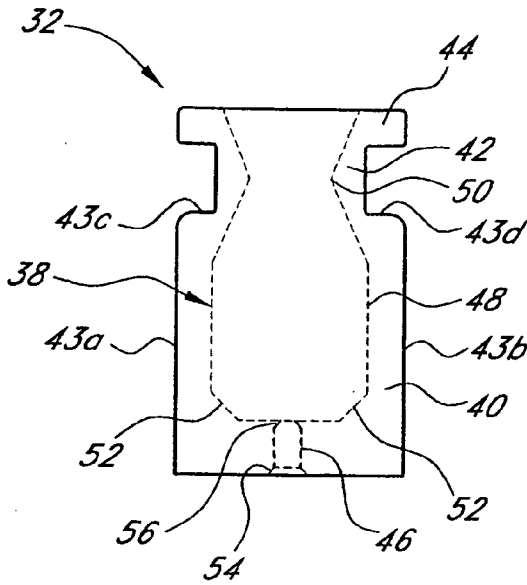

FIG. 6A

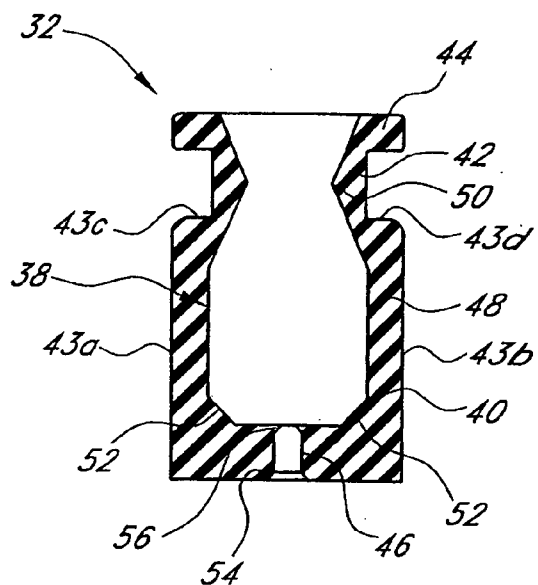

FIG. 6B

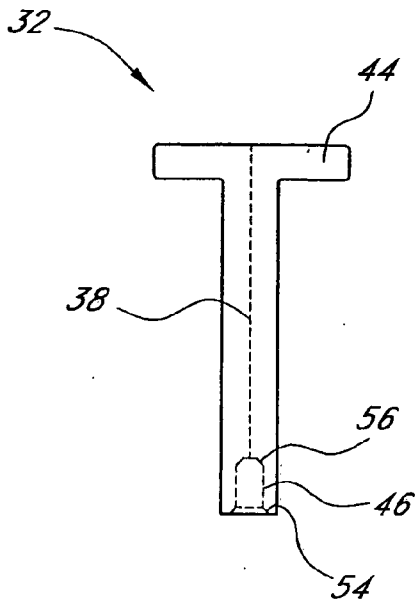

FIG. 7A

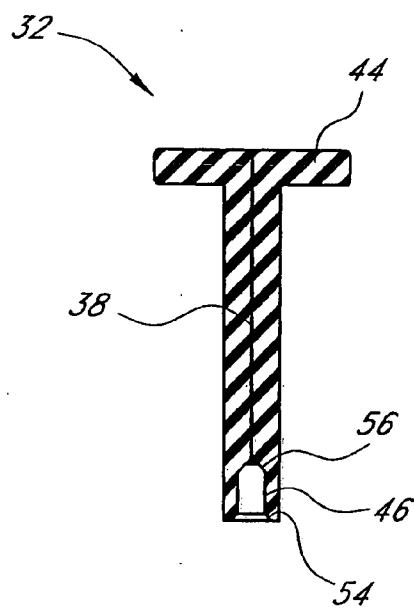

FIG. 7B

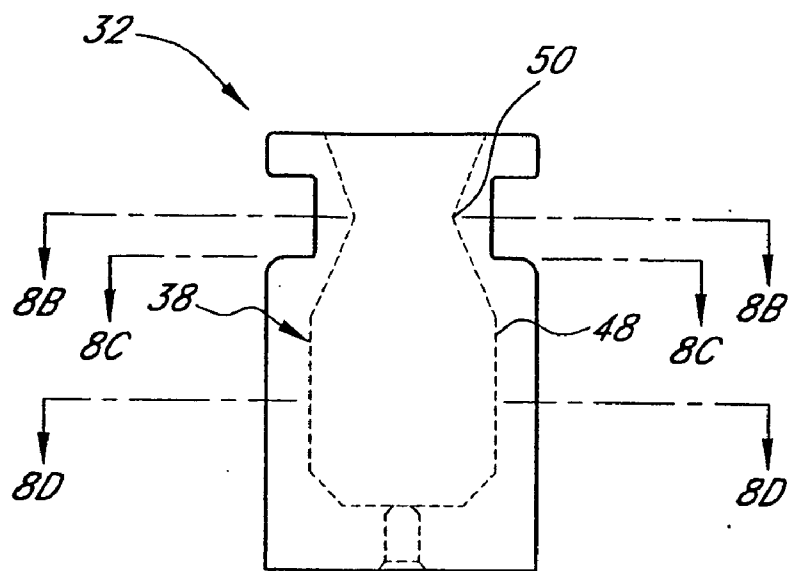

FIG. 8A

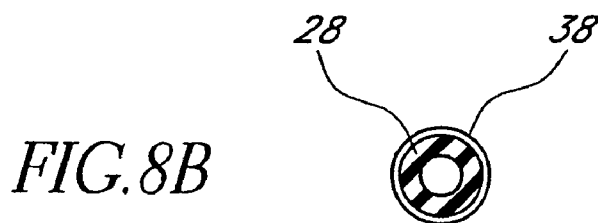

FIG. 8B

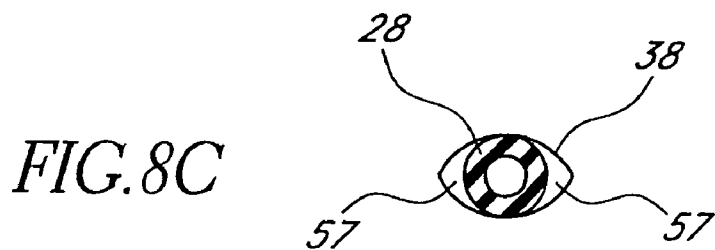

FIG. 8C

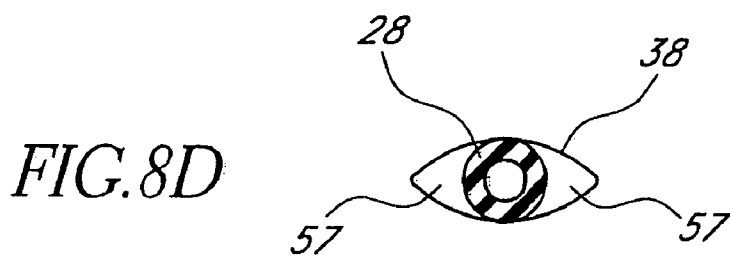

FIG. 8D

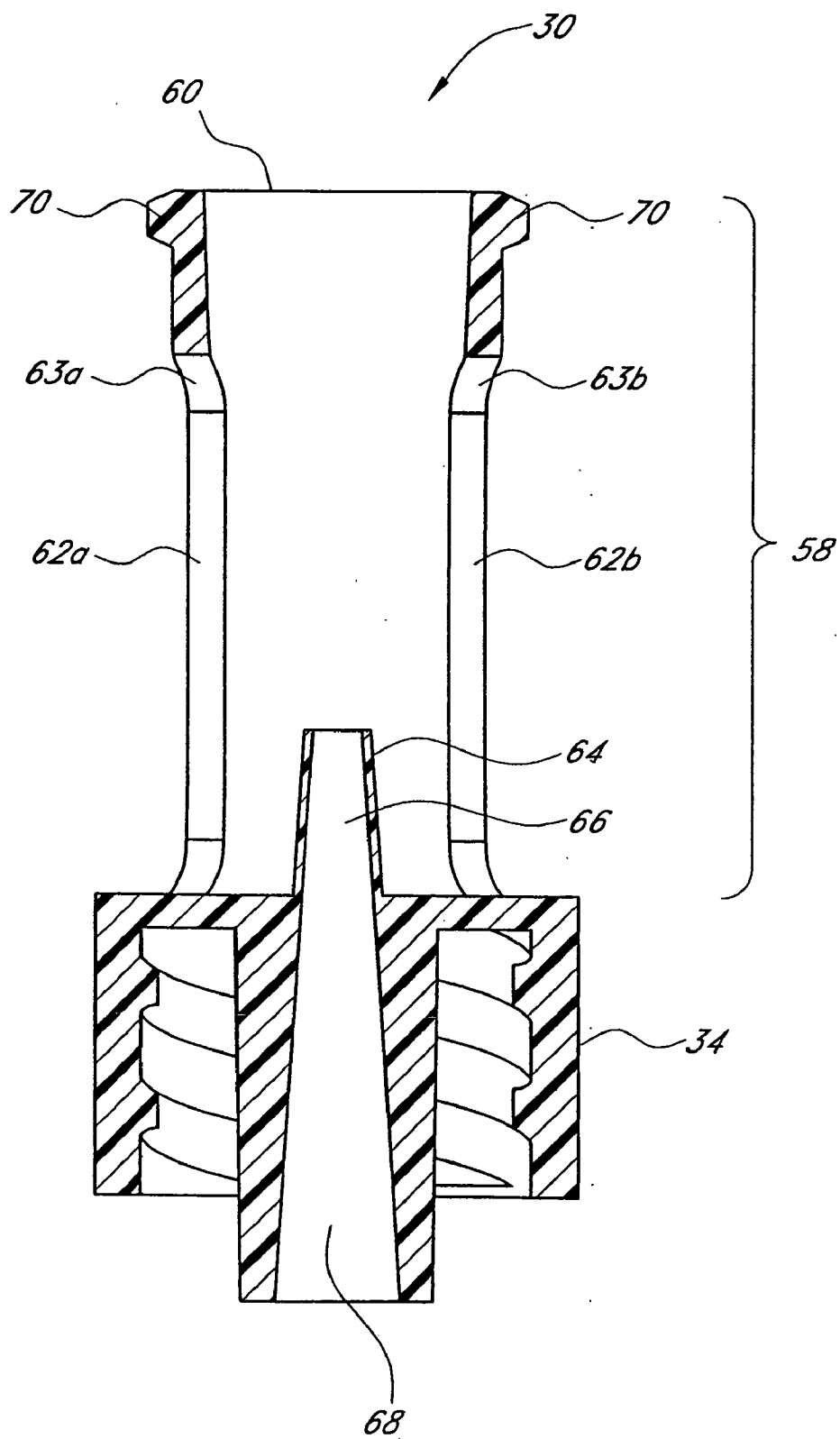
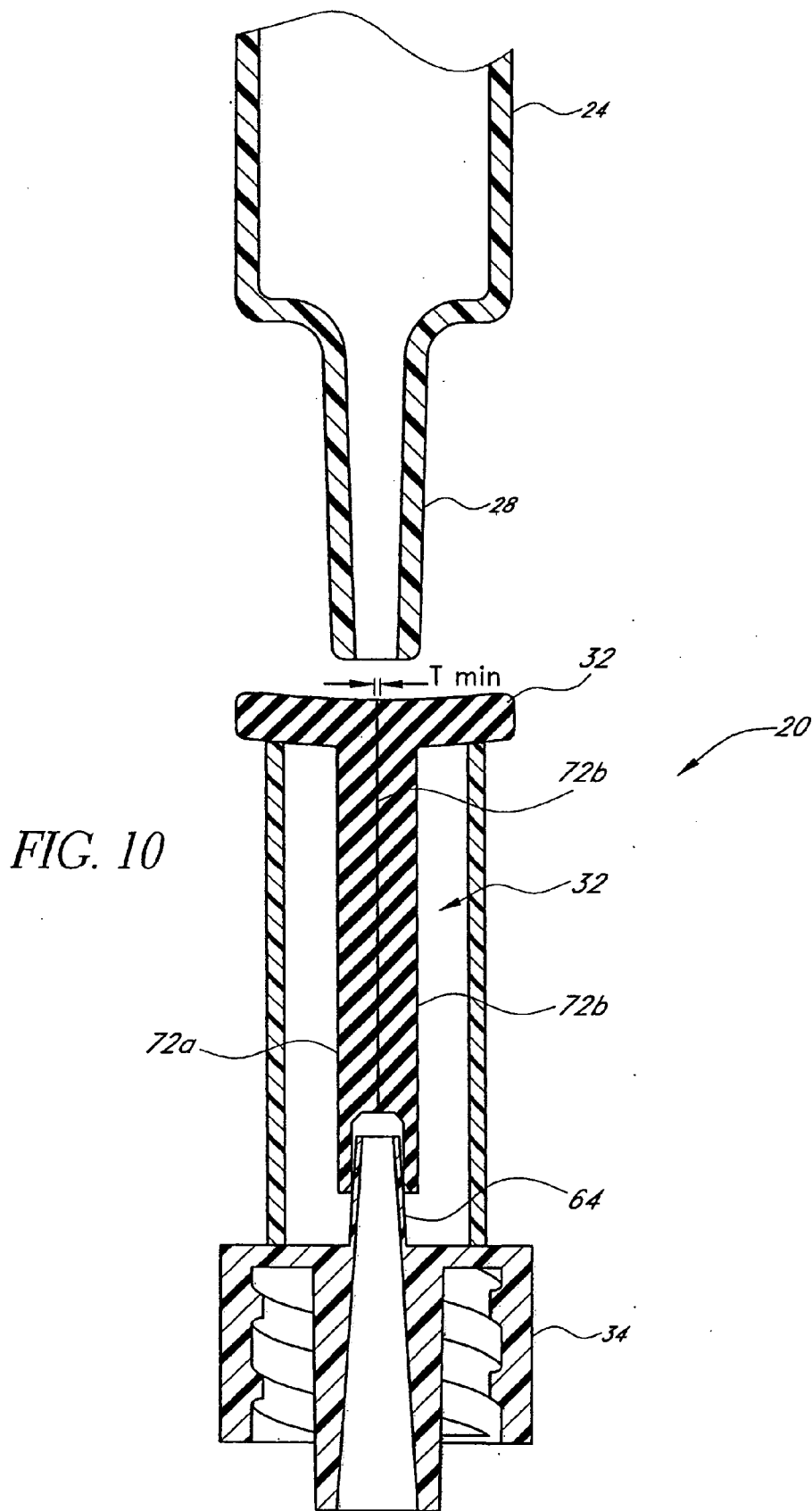

FIG. 9





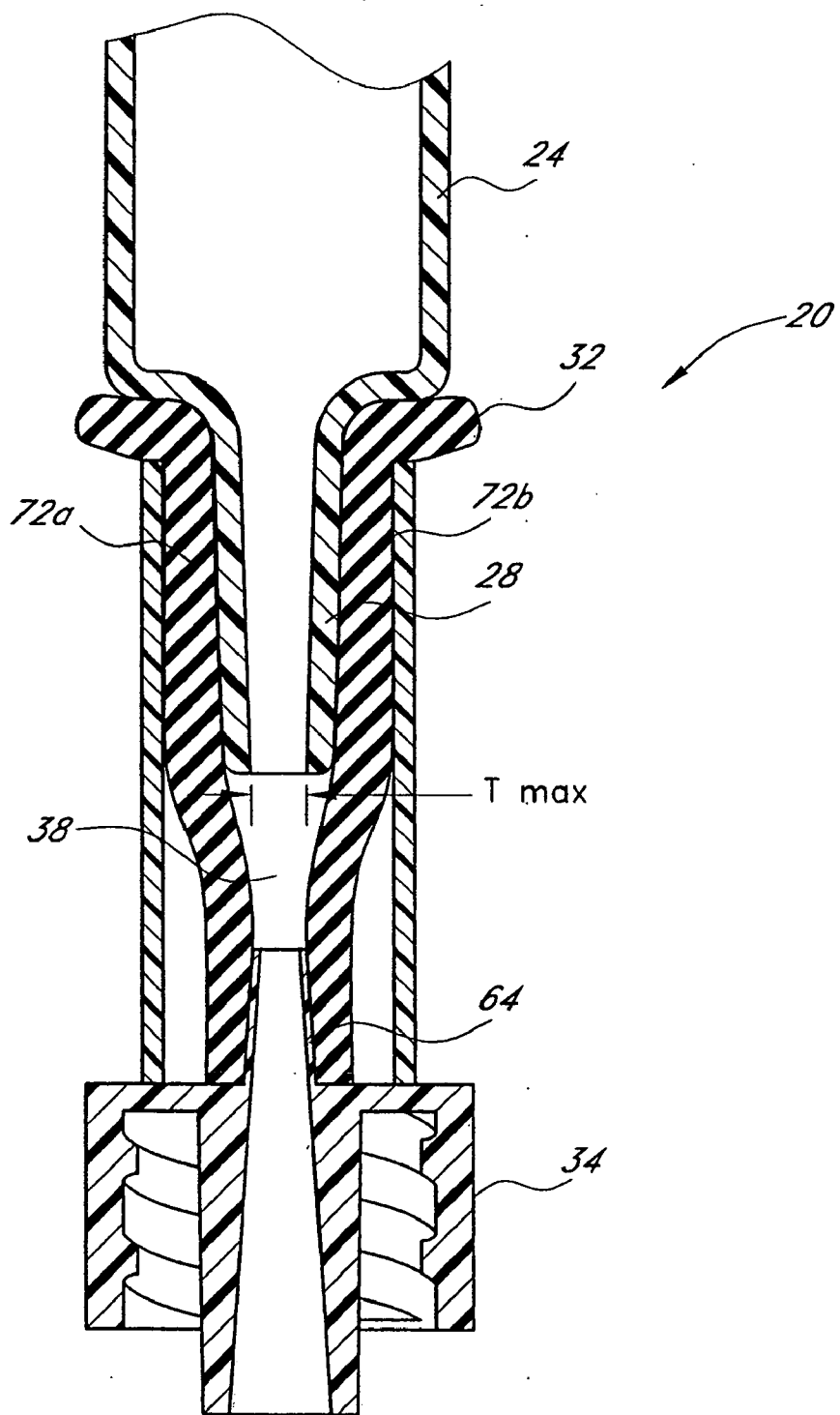

FIG. 11

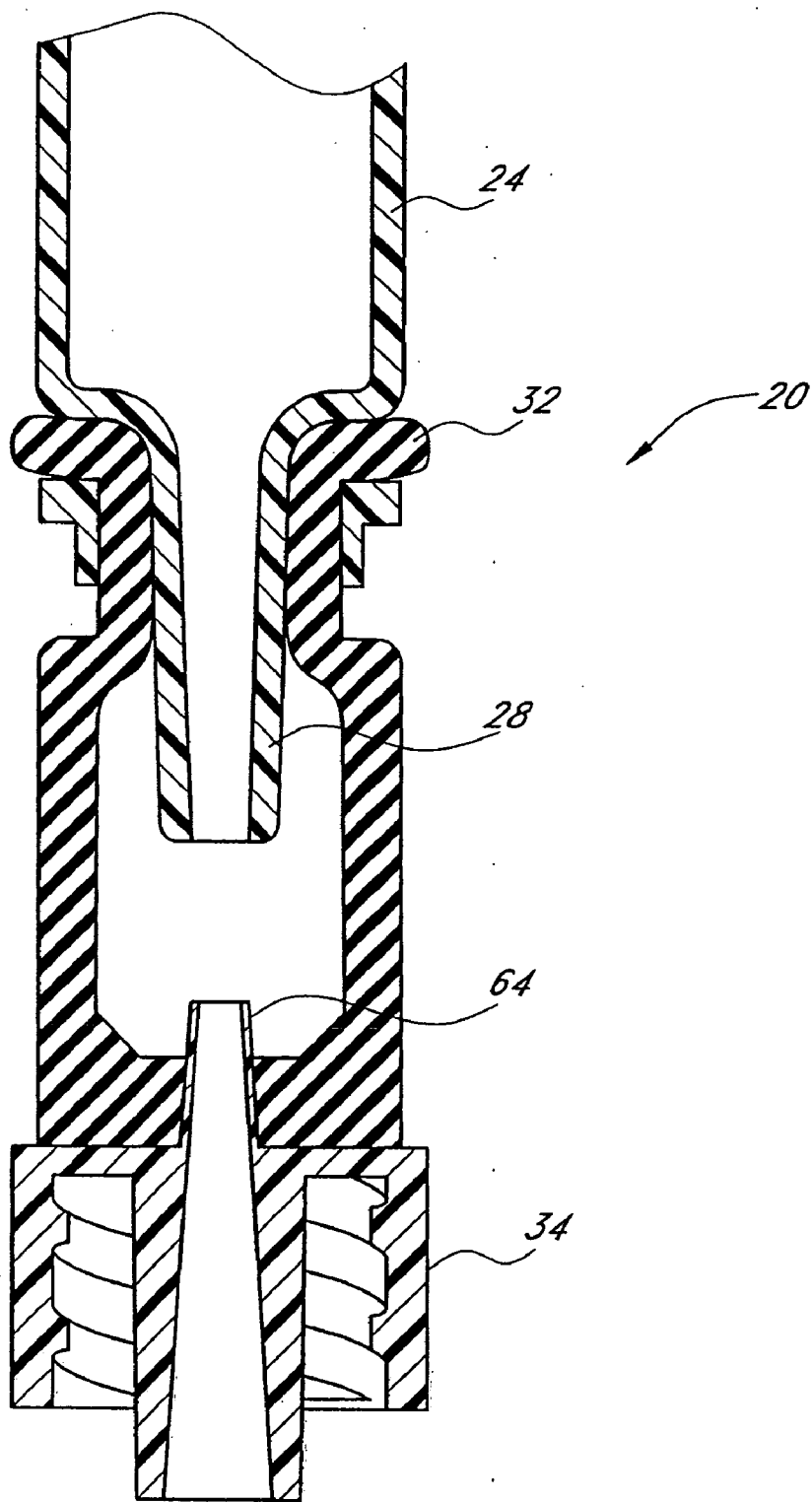
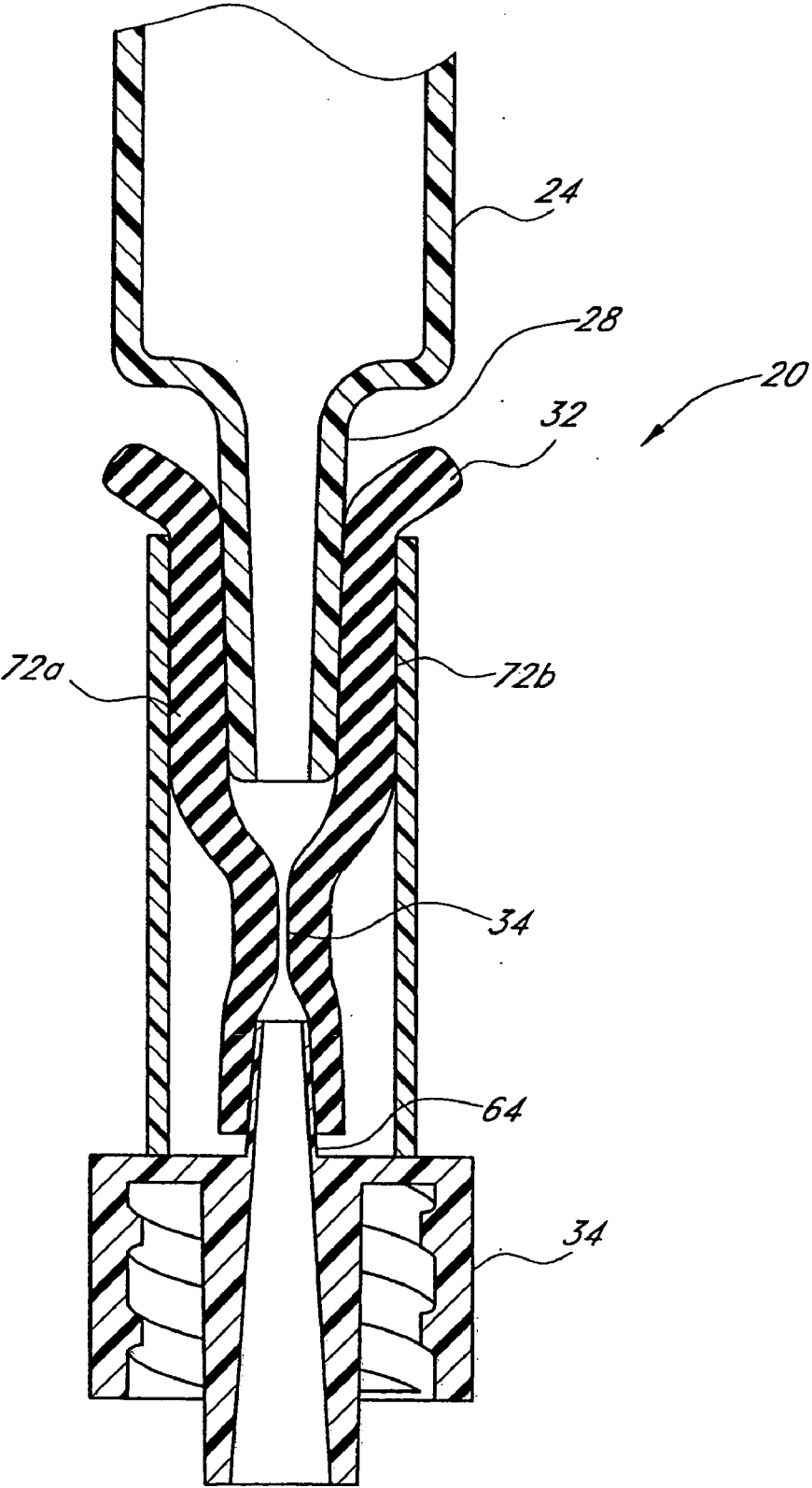
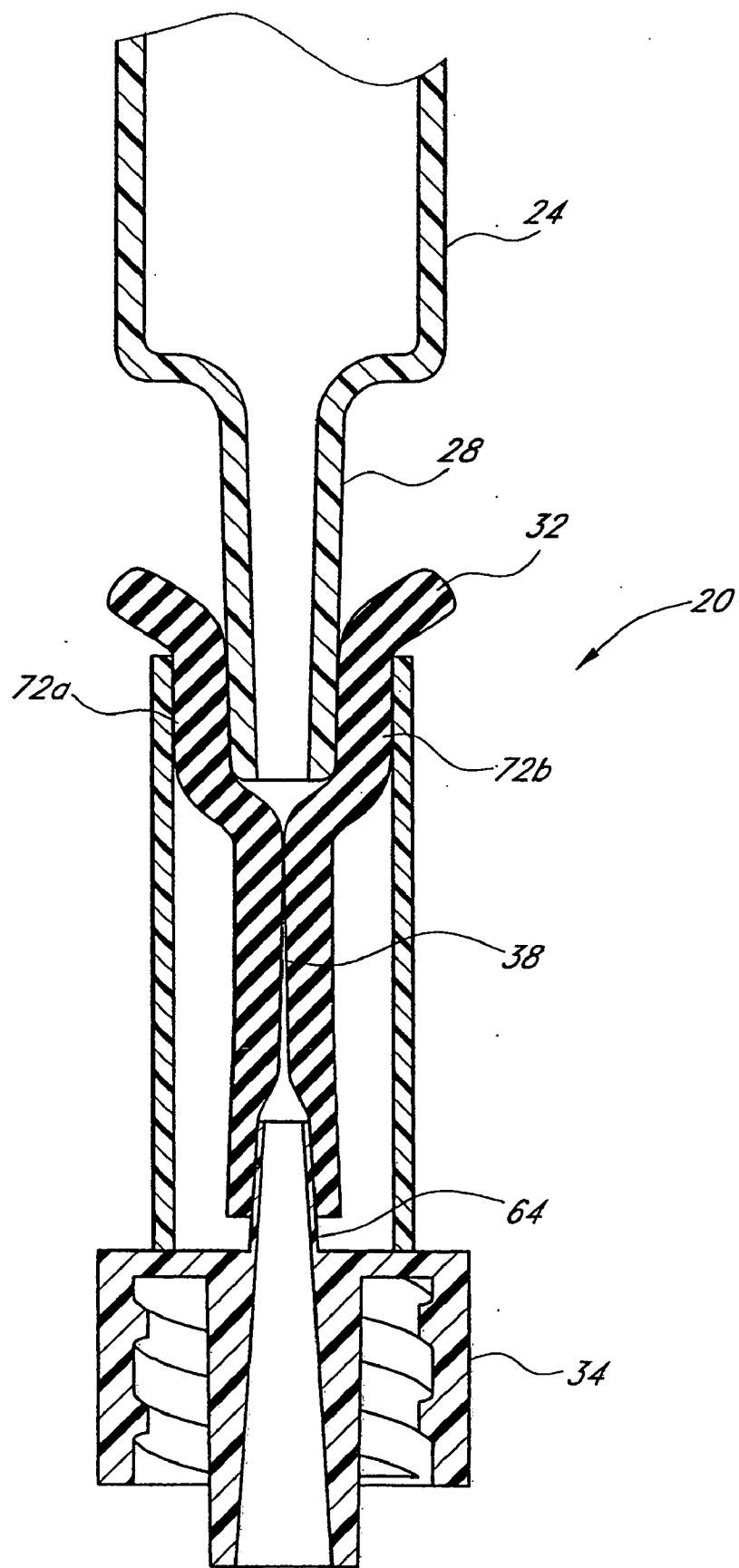
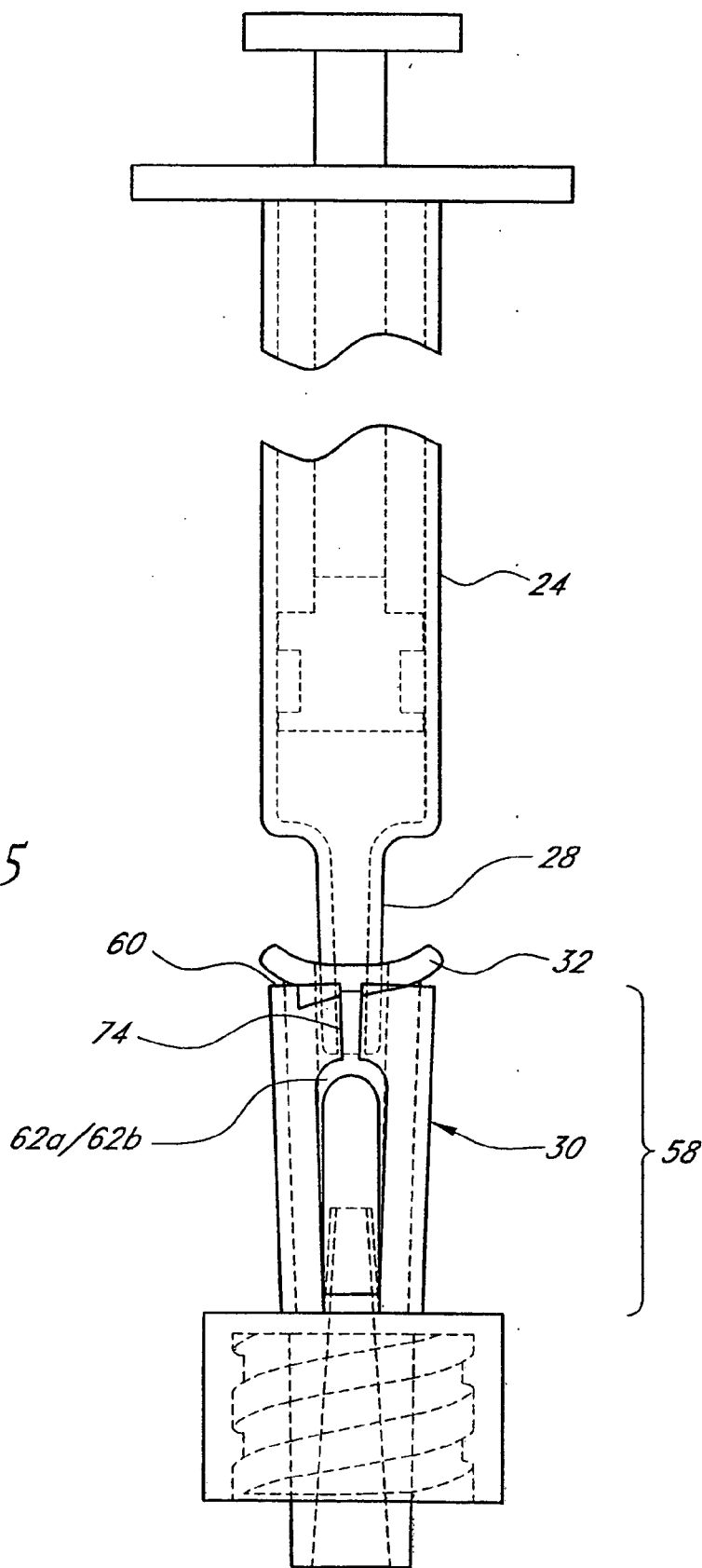
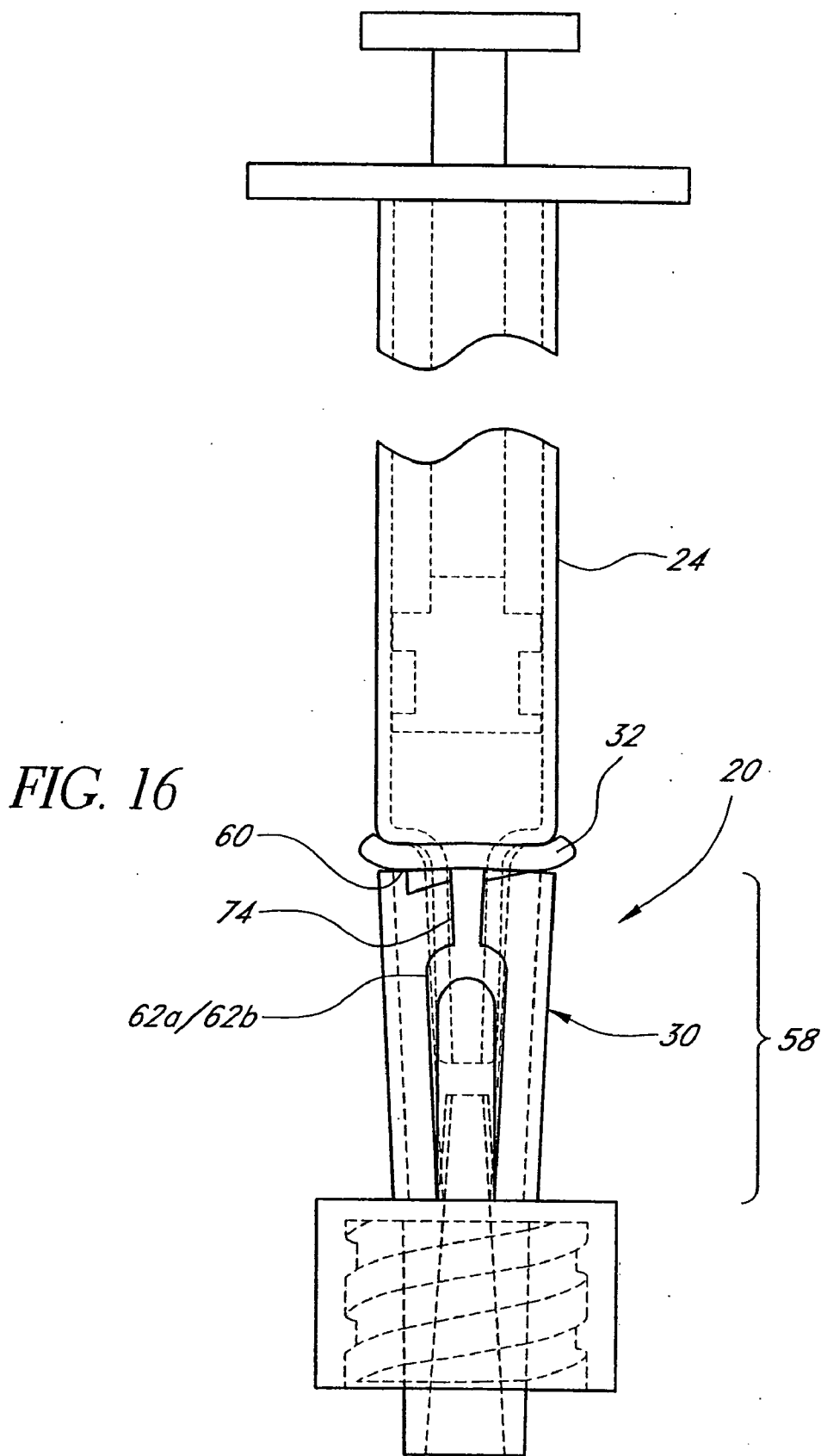

FIG. 12









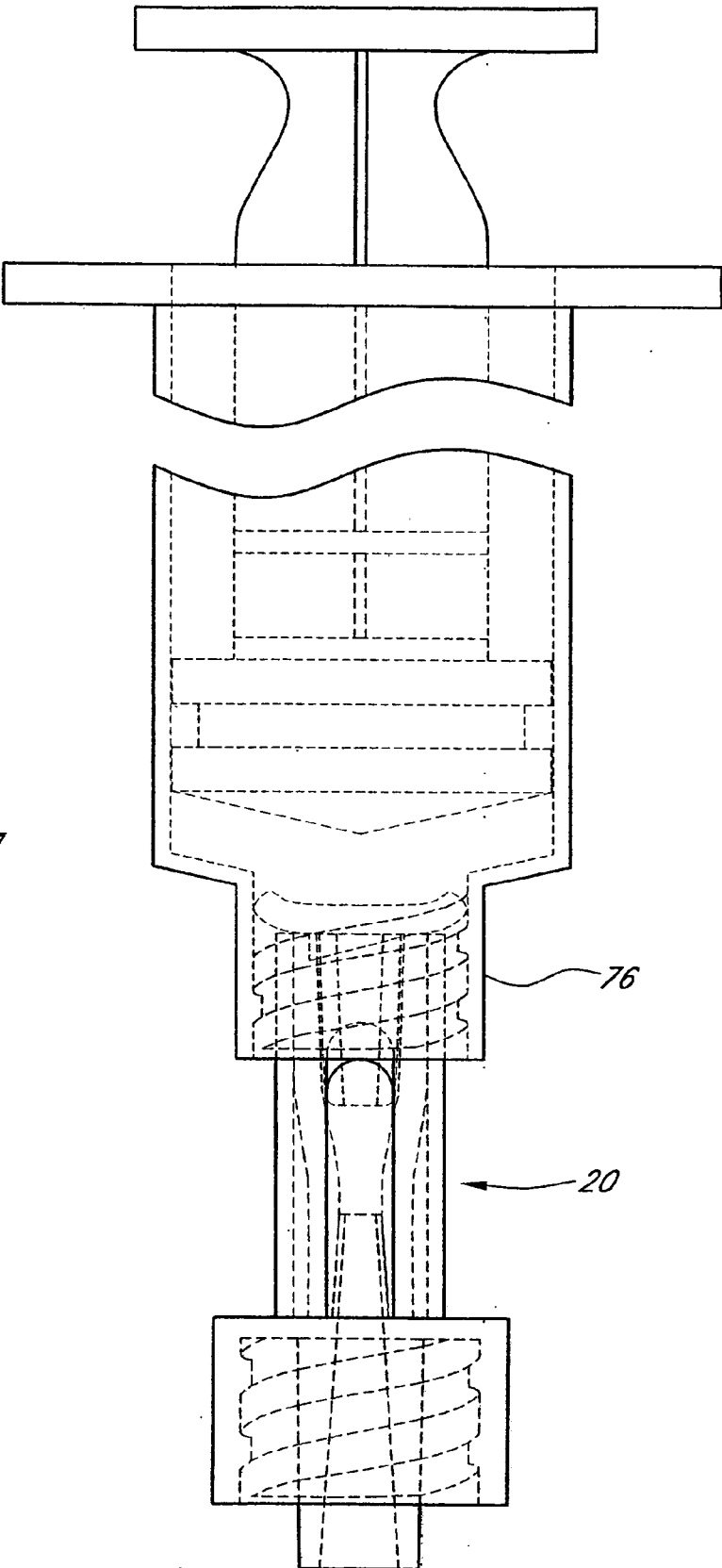
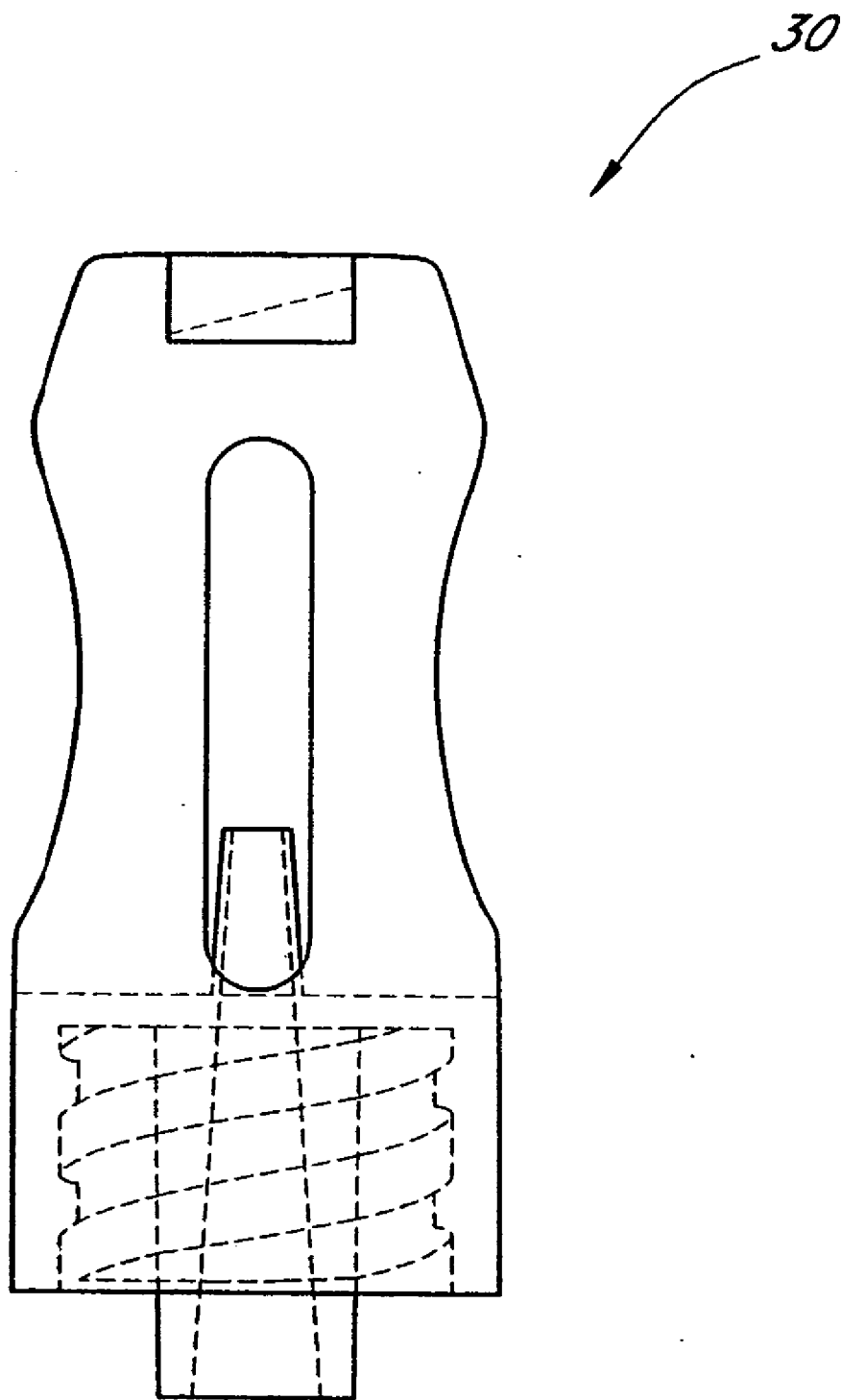

FIG. 17





*FIG. 18*

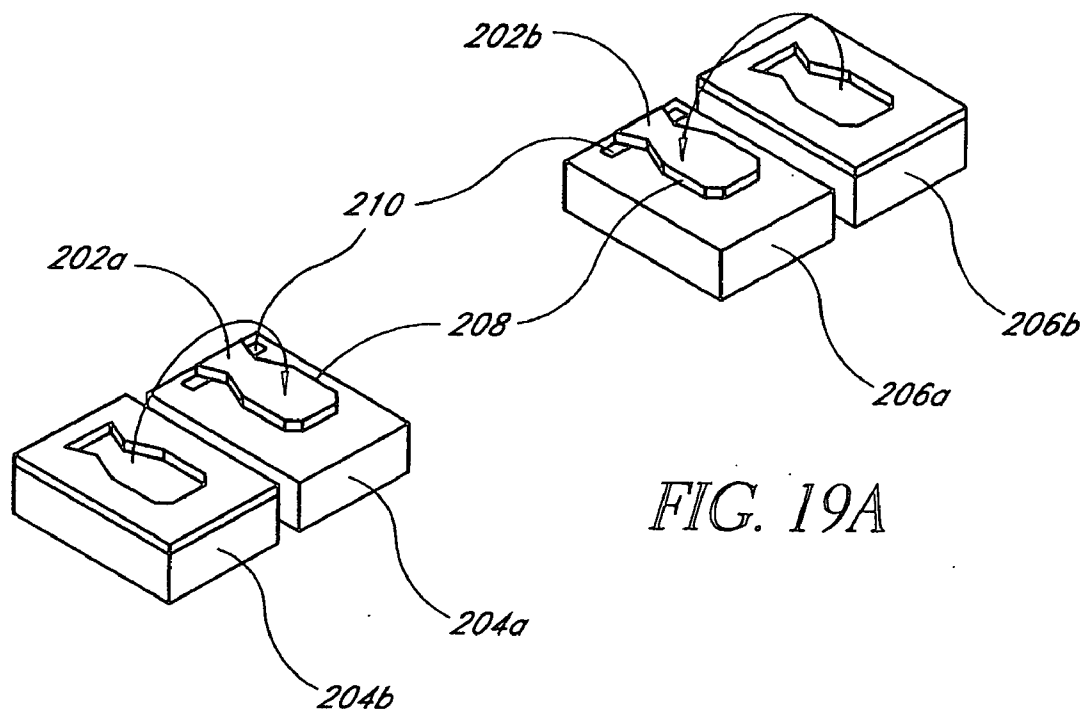

FIG. 19A

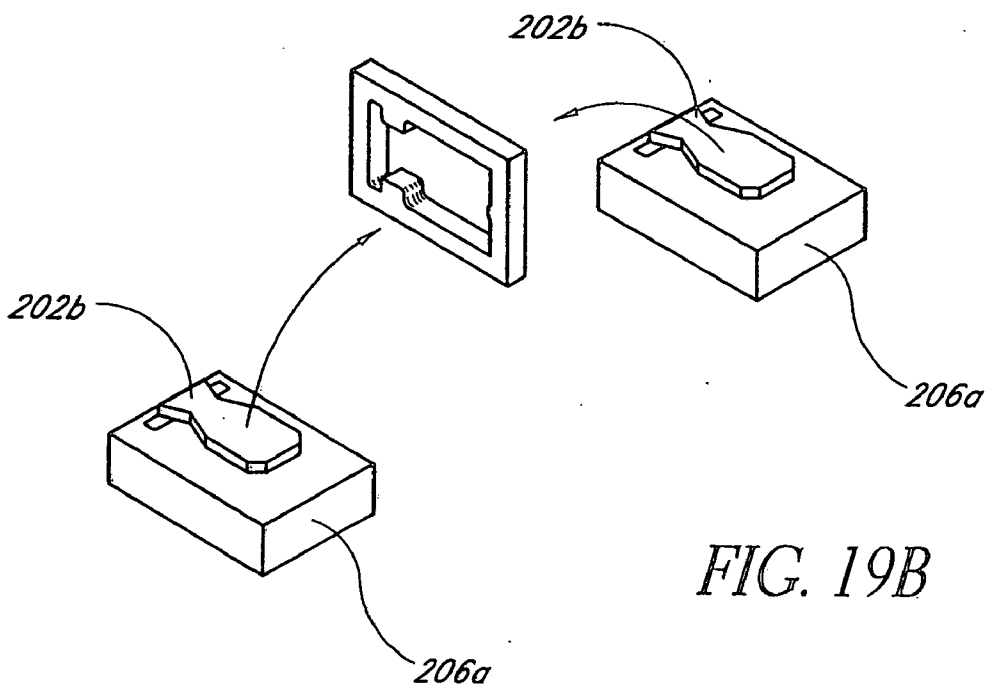

FIG. 19B

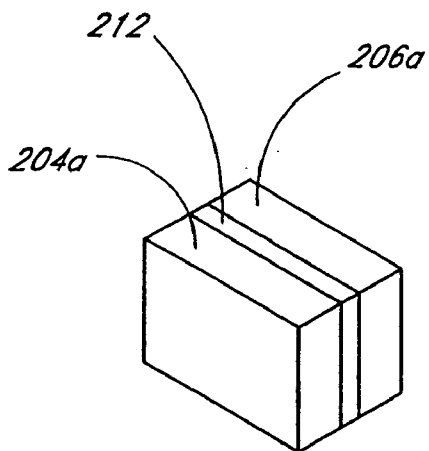

FIG. 19C

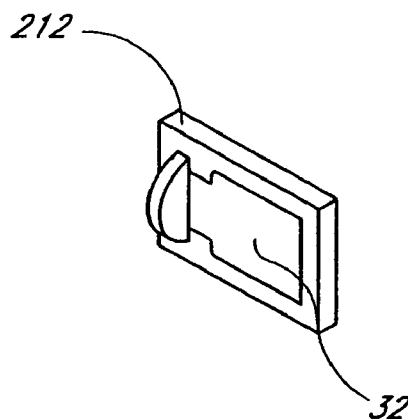

FIG. 19D

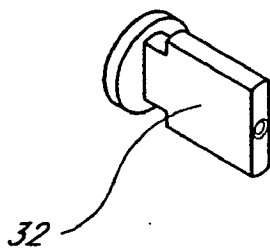

FIG. 19E

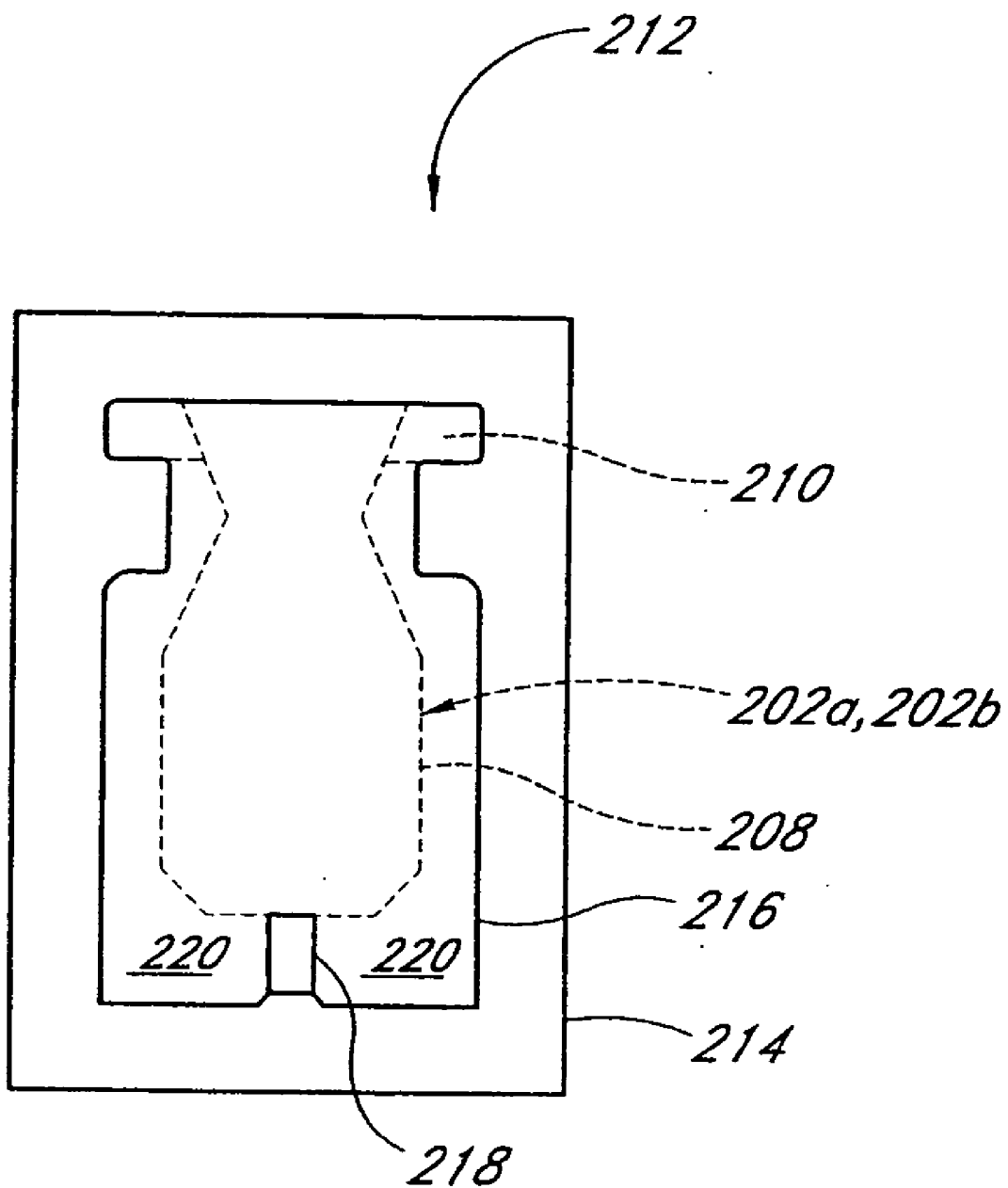

FIG. 20

**MEDICAL VALVE WITH POSITIVE FLOW CHARACTERISTICS**

**RELATED APPLICATIONS**

[0001] This application is a continuation of U.S. patent application Ser. No. 11/157,216, filed Jun. 20, 2005, pending, which is a continuation of U.S. patent application Ser. No. 10/636,163, filed Aug. 7, 2003, now U.S. Pat. No. 6,916,309, which is a continuation of U.S. patent application Ser. No. 09/614,001, filed Jul. 11, 2000, now U.S. Pat. No. 6,695,817, all of which are incorporated herein by reference in their entireties.

**BACKGROUND OF THE INVENTION**

[0002] 1. Field of the Invention

[0003] This invention relates generally to a medical valve, and in particular to a valve which, when connected between a first medical device, such as a fluid source, and a second medical device, such as a catheter, facilitates fluid flow therebetween, and when the first medical device is disconnected therefrom, induces a positive flow of fluid through the valve in the direction of the second medical device.

[0004] 2. Description of the Related Art

[0005] The manipulation of fluids for parenteral administration in hospitals and medical settings routinely involves the use of connectors and valves for selectively facilitating the movement of fluids between two points. These valves are typically placed along a fluid flow line leading to a patient or other destination. For example, the tube may lead to a catheter having its tip positioned within a patient.

[0006] The valve is arranged so that a fluid source or other line may be connected thereto for providing a fluid flow from the source to the patient. When the fluid source or line is removed, the valve closes, sealing the line leading to the patient.

[0007] The element which is connected to the valve may comprise a tube or other medical device such as a conduit, syringe, IV set (both peripheral and central lines), piggyback line, or similar component which is adapted for connection to the medical valve. Unfortunately, prior art valves suffer from a problem arising from the disconnection of these medical devices from the valve.

[0008] These valves define a space within them through which a fluid or other material may flow from the device to the line on which the valve is mounted. When the medical device is connected to the valve, it typically occupies a portion of this internal valve space, displacing the fluid (whether it be a liquid or air) within the valve.

[0009] A problem arises when the medical device is disconnected from the valve. When the device is disconnected, it no longer occupies a portion of the space in the valve. The increase in space within the valve causes the fluid in the valve and line to which the valve is connected, to move to fill the space. In effect, the removal of the device creates a suction force which draws fluid into the valve.

[0010] In the medical setting, this movement of fluid is very undesirable. When the valve is connected to a fluid line leading to a patient, the movement of fluid through the line towards the space in the valve has the effect of drawing

blood from the patient in the direction of the valve. A serious problem may result in that this blood may clot and clog the catheter near its tip, rendering it inoperable, and may even result in a clot of blood in the patient, which may prove fatal.

[0011] One attempt at overcoming this clogging problem has been to coat the inner surface of the catheter near its tip in order to prevent blood from sticking to its interior surfaces. This method has generally been unsuccessful in preventing clogging of the catheter.

[0012] The risk of blood clogging of the catheter is significantly heightened where the inner diameter of the catheter is small (e.g., 27 gauge). These small catheters have the advantage, however, in that they reduce the trauma and discomfort caused by insertion into a patient. Because these catheters have a very small passage therethrough, even a small suction force may draw sufficient amount of fluid back through a catheter toward the valve to introduce blood into the catheter tip, which blood may clog the catheter's passage.

[0013] Overcoming the above-stated problem is made more difficult when considering other criteria which the valve must satisfy. For example, the valve should be arranged to so that it does not have any fluid stagnation points. If the fluid is allowed to stagnate in one or more areas of the valve, bacteria growth and other problems may occur.

[0014] In addition, the valve should have an internal flow path which is smooth. Sharp edges and corners may damage blood cells and cause hemolysis.

[0015] A valve that overcomes the above-stated problems is desired.

**SUMMARY OF THE INVENTION**

[0016] In accordance with one preferred embodiment, a medical valve for selectively permitting fluid to flow between a first medical device and a second medical device comprises a housing that has an interface suitable for receiving a connector portion of the first medical device, and a seal. The seal is made of a flexible material and has a downstream end in fluid communication with the interface, an upstream end suitable for receiving the second medical device, and a normally substantially closed passage in fluid communication with the downstream end and the upstream end. The passage has a relatively small interior volume when in an undisturbed state and a larger interior volume upon the introduction of the second medical instrument into the upstream end of the passage. The passage retracts to define a restricted flow path and a relatively small interior volume upon the withdrawal of the second medical device from the seal (the upstream end initially being sealed as the second medical device is withdrawn) so that a fluid occupying the interior volume is forced toward the downstream end as the passage walls collapse.

[0017] In accordance with another preferred embodiment there is provided a valve seal for use in a medical valve having an interface for fluid communication with a first medical device. The seal comprises a first end in fluid communication with the interface, a second end suitable for receiving a second medical device, and at least one slit in fluid communication with the first end and the second end. The slit defines a restricted fluid flow path and a relatively small interior volume when in an undisturbed state, and

defines an expanded fluid flow path and a larger interior volume upon the introduction of the second medical device into the slit. The slit retracts to define a restricted flow path and a relatively small interior volume upon the withdrawal of the second medical device from the seal.

[0018] In accordance with another preferred embodiment a method is provided for causing a positive flow in the direction of a first medical device from a valve that connects the first medical device to a second medical device and has an associated seal. The seal is adapted to receive at least a portion of the second medical device and provide fluid communication between the first and second medical devices. The method comprises the steps of withdrawing the second medical device from the seal and

[0019] permitting the seal to retract from a large interior volume to a relatively small interior volume so as to displace any fluid within the seal in the direction of the first medical device.

[0020] In accordance with another preferred embodiment there is provided a method of preventing blood from flowing out of a patient into a catheter when a syringe is withdrawn from a valve between the syringe and the catheter. The method comprises the steps of connecting the downstream end of the valve to the catheter and inserting the end of the syringe into a slit forming the upstream end of a normally substantially closed seal passage that is located in a resilient seal and is in fluid communication with the downstream end of the valve. This causes the seal passage to open while providing sealing contact between the syringe and the upstream end of the seal passage. The method further comprises the steps of injecting fluid from the syringe through the seal passage to the catheter and into the patient, and withdrawing the syringe, allowing the walls of the seal passage to return to their substantially closed position while initially maintaining sealing contact between the upstream end and the syringe. This provides a force urging fluid in the passage toward the catheter.

[0021] In accordance with another preferred embodiment there is provided a medical valve for selectively permitting fluid to flow between a first medical device and a second medical device through an associated seal. The valve comprises an interface suitable for receiving a connector portion of the first medical device, and a seal holder in fluid communication with the interface.

[0022] In accordance with another preferred embodiment a system for administering fluid to a blood vessel of a patient comprises a catheter having an upstream end and a downstream end that is suitable for placement in fluid communication with the blood vessel, and a syringe suitable for expelling fluid into the catheter. The system further comprises a valve having a fitting suitable for connection to the upstream end of the catheter and providing selective fluid communication between the syringe and the catheter. The valve further comprises a seal made of a flexible material. The seal has a downstream end in fluid communication with the fitting, an upstream end suitable for receiving the syringe, and a normally substantially closed passage in fluid communication with the downstream end and the upstream end. The passage has a relatively small interior volume when in an undisturbed state and a larger interior volume upon the introduction of the syringe into the upstream end of the passage. The passage retracts to define a restricted flow path

and a relatively small interior volume upon the withdrawal of the second medical device from the seal (the upstream end initially being sealed as the syringe is withdrawn), so that a fluid occupying the interior volume is forced toward the downstream end as the passage walls collapse.

[0023] In accordance with another preferred embodiment there is provided a method of making a medical valve seal of the type having a body made of a flexible material and at least one slit formed within the body between adjacent first and second slit walls. The method comprises molding first and second preforms, each preform comprising one of the first and second slit walls and a perimeter edge portion, and pressing the first and second preforms together so that the first and second slit walls face each other. The method further comprises molding an additional amount of a flexible material to at least part of the perimeter edge portions of the first and second preforms so that the first and second preforms and the additional material form a unitary mass with the slit formed therein.

[0024] For purposes of summarizing the invention and the advantages achieved over the prior art, certain objects and advantages of the invention have been described herein above. Of course, it is to be understood that not necessarily all such objects or advantages may be achieved in accordance with any particular embodiment of the invention. Thus, for example, those skilled in the art will recognize that the invention may be embodied or carried out in a manner that achieves or optimizes one advantage or group of advantages as taught herein without necessarily achieving other objects or advantages as may be taught or suggested herein.

[0025] All of these embodiments are intended to be within the scope of the invention herein disclosed. These and other embodiments of the present invention will become readily apparent to those skilled in the art from the following detailed description of the preferred embodiments having reference to the attached figures, the invention not being limited to any particular preferred embodiment(s) disclosed.

#### BRIEF DESCRIPTION OF THE DRAWINGS

[0026] Having thus summarized the general nature of the invention and its essential features and advantages, certain preferred embodiments and modifications thereof will become apparent to those skilled in the art from the detailed description herein having reference to the figures that follow, of which:

[0027] **FIG. 1** is a schematic view of the use of a valve in accordance with the invention to interconnect a catheter with a fluid source such as a syringe;

[0028] **FIG. 2** is a perspective view of the valve;

[0029] **FIG. 3** is a front elevation view of the valve;

[0030] **FIG. 4** is a side elevation view of the valve;

[0031] **FIG. 5** is a perspective view of a seal for use in the valve;

[0032] **FIG. 6A** is a front elevation view of the seal;

[0033] **FIG. 6B** is a front cross-sectional view of the seal;

[0034] **FIG. 7A** is a side elevation view of the seal;

[0035] **FIG. 7B** is a side cross-sectional view of the seal;

- [0036] **FIG. 8A** is a front elevation view of the seal;
- [0037] **FIGS. 8B-8D** are cross-sectional schematic views of the insertion of a medical device into the seal taken through lines 8B-8B, 8C-8C and 8D-8D of **FIG. 8A**, respectively;
- [0038] **FIG. 9** is a front cross-sectional view of a housing for use in the valve;
- [0039] **FIG. 10** is a side cross-sectional view of the valve and the syringe before insertion of the syringe into the valve;
- [0040] **FIG. 11** is a side cross-sectional view of the valve with the syringe fully inserted;
- [0041] **FIG. 12** is a front cross-sectional view of the valve with the syringe fully inserted;
- [0042] **FIG. 13** is a side cross-sectional view of the valve with the syringe partly withdrawn;
- [0043] **FIG. 14** a side cross-sectional view of the valve with the syringe further withdrawn in comparison to **FIG. 13**;
- [0044] **FIG. 15** is a side elevation view of an alternative embodiment of the valve, with the syringe partly inserted;
- [0045] **FIG. 16** is a side elevation view of an alternative embodiment of the valve, with the syringe fully inserted;
- [0046] **FIG. 17** is a front elevation view of the valve as used with a syringe having a Luer lock;
- [0047] **FIG. 18** is a side elevation view of an alternative embodiment of the valve housing;
- [0048] **FIGS. 19A-19E** are schematic views of a process of making the seal; and
- [0049] **FIG. 20** is a plan view of an overmold plate used in making the seal.

#### DETAILED DESCRIPTION OF THE PREFERRED EMBODIMENT

[0050] **FIGS. 1-9** depict a valve **20** in accordance with a preferred embodiment of the invention. **FIG. 1** illustrates a particular use of the valve **20** to which it is well suited. Of course, the valve **20** may be used in a variety of other manners.

[0051] As illustrated in **FIG. 1**, the valve **20** may advantageously be used to selectively control the flow of fluid to a first medical device (such as a catheter **22** shown here) from a second medical device (generally comprising a fluid source such as an ISO standard syringe **24**). In this arrangement, the catheter **22** is connected to one end of the valve **20** and has a tip **26** inserted into the arm of a patient. The syringe **24** has a cannula tip or Luer **28** that is inserted into the other end of the valve **20**, which is designed to accept the Luer **28** of the syringe **24** without a needle installed on the Luer.

[0052] When so connected, the valve **20** permits fluid to flow from the syringe **24** to the catheter **22** and into the patient. The valve **20** is also arranged so that when the syringe **24** is disconnected, fluid flow through the valve **20** is prevented. In addition, when the syringe **24** is disconnected, the valve **20** generates a "positive" fluid flow, i.e.

flow of fluid in the direction of the patient, thereby preventing blood from entering the catheter **22** and causing the associated adverse effects.

[0053] **FIGS. 2-4** depict one preferred embodiment of a valve **20** in accordance with the invention. The valve **20** comprises a relatively rigid housing **30** and a relatively flexible and resilient seal **32** disposed on or within the housing **30**. The housing **30** has a Luer lock interface **34** at its lower end to facilitate connecting the valve **20** to a variety of medical devices. One skilled in the art will readily appreciate that a number of other interface or connection types are suitable for use in place of the Luer lock **34**, such as a Luer slip connection or a barbed hose fitting.

[0054] The seal **32** has a slit opening **36** (best seen in **FIG. 2**) which is configured to permit the Luer **28** of a syringe **24** (see **FIG. 1**) to enter the seal **32** upon application of moderate pressure by the user. The syringe Luer **28** thus enters a slit **38** (see **FIG. 3**) formed in the interior of the seal **32**. With the syringe Luer **28** thus inserted, the seal permits fluid ejected from the syringe **24** through the Luer **28** to flow through the slit **38** and Luer lock **34** and into the catheter **22** or other medical device attached to the Luer lock **34**.

[0055] **FIGS. 5-7B** show the seal **32** removed from the housing for purposes of clarity. The seal **32** has a body **40** which may take the form of a slab having a flat, generally rectangular shape. Like the entirety of the seal **32**, the body **40** is preferably formed of molded, 50 durometer silicone rubber, or is alternatively formed of synthetic polyisoprene. At one end of the body **40** is formed a flat, generally rectangular neck **42** and a generally circular transverse flange **44**. The neck **42** is situated between first and second lateral extensions **43a**, **43b** which have shoulders **43c**, **43d** comprising those portions of the lateral extensions nearest the flange **44**. The body **40**, neck **42** and flange **44** thus form an integral unit, inside of which is formed the (preferably substantially planar) slit **38**. The slit **38** extends from the slit opening **36** (best seen in **FIG. 2**) in the flange **44** to a lead lumen **46** formed in an end of the body **40** opposite the flange **44**. The lead lumen **46** is preferably substantially cylindrical and centered about an axis that is substantially parallel to or collinear with the longitudinal axis of the seal. The slit **38** is preferably substantially planar and of virtually no thickness unless a Luer is connected. The slit **38** thus forms (in its undisturbed state, i.e. when the syringe Luer **28** has not been inserted into the seal **32**) a highly restricted fluid flow path from the slit opening **36** to the lead lumen **46**. As used herein in reference to a flow path, "restricted" means a flow path that permits either no fluid, or a clinically negligible amount of fluid, to pass.

[0056] The preferred configuration of the slit **38** and lead lumen **46** is best seen in **FIGS. 6A-7B**. The slit **38** has a body portion **48** within the body **40** of the seal **32**. Advantageously, the body portion **48** is a region of maximum width, preferably about 0.228", of the slit **38**. The slit **38** tapers to a point or region **50** of minimum width, which is preferably located within the neck **42**. Advantageously, at the region **50** of minimum width the slit **38** is preferably about 0.120" wide. In other words, the width of the slit **38** in the body portion **48** is almost twice that of the region **50** of minimum width. From the region **50** of minimum width the slit **38** tapers outward to the slit opening **36**, where it attains a preferred width of about 0.200". This tapered

configuration acts as lead-in for insertion of the syringe Luer 28 into the slit 38. The slit 38 may also have beveled corners 52 at its lower end, opposite the neck 42. At its lower end the slit 38 connects to the lead lumen 46 to facilitate fluid communication between the slit 38 and the lead lumen 46. The lead lumen 46 preferably has a lead-in chamfer 54 and a beveled transition 56 to the slit 38. The preferred inside diameter of the lead lumen 46 is about 0.040".

[0057] In the side views of FIGS. 7A and 7B, it may be seen that the seal 32 has a T-shaped cross section before installation in the housing 30, with the flange 44 forming the cross portion of the "T". Viewed from the side, the slit 38 is uniformly thin, i.e. of no or virtually no thickness, as it runs from the top of the seal 32 to the lead lumen 46. However, upon installation in the housing 30, the thickness of the slit 38 (when viewed from the side) will vary somewhat as will be explained in greater detail below.

[0058] FIGS. 8A-8D show the effects, in terms of sealing performance, of the varying width of the slit 38 after introduction of a syringe Luer 28 into the slit 38. (The syringe Luer 28 is not shown in FIG. 8A for purposes of clarity.) FIG. 8B shows the arrangement of the slit 38 and the syringe Luer 28 at the region 50 of minimum width, when the Luer 28 has been fully inserted into the slit 38. Due to the relative narrowness of the slit 38 at the region 50, the slit 38 draws up against substantially the entire perimeter of the syringe Luer 28 at that location, creating a relatively tight perimeter seal between the slit 38 and the Luer 28. In other words, the perimeter of the open slit 38 at the region 50 is less than the circumference of the Luer 28.

[0059] FIGS. 8C and 8D show that where the slit 38 is wider (i.e., in the body portion 48 of the slit and the transition from the region 50) the slit no longer contacts the entire perimeter of the syringe Luer 28, leaving gaps 57 on one or both sides and the end of the Luer 28. In other words, the perimeter of the open slit in the body portion 48 is greater than the circumference of the Luer 28. As will be discussed in greater detail below, this arrangement of a slit-Luer seal near the top of the slit 38 and a fluid-occupiable volume (in the form of the gaps 57) below the slit-Luer seal, promotes a positive-flow function for the valve 20 when the syringe Luer 28 is withdrawn.

[0060] FIGS. 3, 4, and 9 show a preferred configuration of the housing 30 and the installation of the seal 32 therein. The housing 30 is preferably formed of molded polycarbonate, or alternatively formed from any suitable thermoplastic. The housing 30 has a seal holder 58 attached to the Luer lock 34; the seal holder preferably has a cylindrical configuration, but may comprise any shape or construction sufficient to hold the seal 32 on or in the housing 30 without interfering with operation of the valve 20. The seal holder has an axial opening 60 opposite the Luer lock 34, and first and second side openings 62a, 62b which have first and second top edges 63a, 63b that comprise the edges of the side openings nearest the axial opening 60. A lead cannula 64 (best seen in FIG. 9) extends from the Luer lock 34 toward the axial opening 60 and contains an internal lumen 66 which is in fluid communication with a lumen 68 in the Luer lock 34. The lead cannula 64 is preferably substantially cylindrical or frusto-conical in shape and centered about an axis that is substantially parallel to or collinear with the longitudinal axis of the housing 30. A pair of lugs 70 are positioned on

the end of the seal holder 58 near the axial opening 60, to permit a Luer lock or other threaded connection (not shown) to threadably engage the housing 30 at the axial opening 60.

[0061] As best seen in FIGS. 3 and 4, most of the seal 32 is situated within the seal holder 58, with the first and second lateral extensions 43a, 43b of the seal 32 protruding from the first and second side openings 62a, 62b. The lead lumen 46 of the seal 32 is situated so that the lead cannula 64 extends at least partway into the lead lumen, facilitating fluid communication between the seal 32 and the Luer lock 34. The flange 44 covers the axial opening 60 and contacts the adjacent edges of the opening. Preferably, the distance between the axial opening 60 and the top edges 63a, 63b of the side openings 62a, 62b is slightly larger than the distance between the flange 44 and the shoulders 43c, 43d of the lateral extensions 43a, 43b. This arrangement results in the application of a tensile force or preload to the seal 32 between the flange 44 and the lateral extensions 43a, 43b. The preload arises as the shoulders 43c, 43d bear against the top edges 63a, 63b and the flange 44 bears against the edges of the axial opening 60. The preload causes the flange 44 to assume a slightly bowl-shaped or concave configuration as the edges of the axial opening 60 bear against the underside of the flange 44. The bowl-shaped flange 44 thus serves as a lead-in for the insertion of the syringe Luer 28 into the slit opening 36 (best seen in FIG. 2), and tends to pinch closed the slit opening 36 and thus enhances the ability of the seal 32 to prevent fluid flow. The preload also prevents buckling of the seal along its longitudinal axis and maintains the sides of the slit 38 in close proximity along their entire length. The preload thus promotes a relatively thin slit below the flange 44, which enhances the sealing performance of the slit 38.

[0062] FIGS. 10-14 illustrate the function of the valve 20 as a syringe Luer 28 is inserted into and withdrawn from the slit 38. FIG. 10 shows the valve 20 prior to insertion of the syringe Luer 28; at this point the slit 38 defines a substantially closed or highly restricted flow path through the seal 32, marked by a very thin (or substantially nonexistent) path thickness  $T_{\min}$  between slit walls 72a, 72b. This thin or nonexistent path thickness  $T_{\min}$  prevails along most or substantially all of the length of the slit 38 below the flange 44. This condition restricts fluid flow through the seal 32 so as to seal off the catheter 22 (see FIG. 1) or other medical device connected to the Luer lock 34. At this point the slit 38 also defines a relatively small interior volume  $V_{\min}$  within the seal 32, between the slit walls 72a, 72b. (As used herein in reference to an interior volume of the seal, "relatively small" means a volume that is either nonexistent or clinically negligible in size.) In this initial state, the seal 32 is situated upon the lead cannula 64 such that substantially none of the lead cannula 64 extends into the slit 38.

[0063] FIGS. 11 and 12 show the valve 20 after the syringe Luer 28 has been completely inserted into the slit 38. The seal 32 has also been stretched or forced downward onto the lead cannula 64, at least part of which penetrates into the slit 38 itself. At this point the slit 38 defines an expanded flow path through the seal 32, in that the slit walls 72a, 72b have spread to a path width  $T_{\max}$ . The seal 32 thus permits fluid to flow between the syringe 24 and the catheter 22. In addition, the slit 38 now defines a larger or maximum interior volume  $V_{\max}$ .  $V_{\max}$  comprises the entire space between the slit walls 72a, 72b less the volume taken up by the cannula (but not the internal lumen) of the syringe Luer



28 and less that portion of the lead cannula 64 which has penetrated into the slit 38. Accordingly, under pressure exerted via the syringe 24 an amount of fluid substantially equivalent to  $V_{\max}$  now fills the slit 38 between the slit walls 72a, 72b. This is also shown as gaps 57 in FIGS. 8C and 8D.

[0064] FIGS. 13 and 14 show the function of the slit 38 as the syringe Luer 28 is withdrawn from the valve 20. As the syringe Luer 28 and lead cannula 64 exit the slit, the slit walls 72a, 72b retract to substantially their original configuration to once again define a narrow path width (approaching  $T_{\min}$ ) between them. This retraction of the slit walls 72a, 72b reduces the volume between the walls; that is, the internal volume within the slit 38 is decreasing from  $V_{\max}$ . Thus the amount of fluid within the slit must also decrease from  $V_{\max}$ . Accordingly, the retracting slit walls 72a, 72b displace the fluid from the slit 38 as the syringe Luer 28 is withdrawn.

[0065] The fluid thus displaced cannot flow out of the slit 38 through the top of the seal 32. As detailed above with regard to FIGS. 8A-8B, the slit 38 maintains a tight seal against the syringe Luer 28 at the region 50 of minimum width as the syringe Luer 28 is withdrawn. In addition, the displaced fluid cannot flow into the interior of the syringe 24 at all times relevant to the use of the valve 20. Therefore, substantially all of the displaced fluid must exit the slit 38 through the lead cannula 64 and Luer lock 34, resulting in positive flow from the valve 20 upon withdrawal of the syringe Luer 28.

[0066] FIGS. 15-18 show variations on the valve 20 disclosed above, which variations may be desirable under certain operating conditions. For example, as seen in FIGS. 15 and 16 the housing 30 may have a break 74 running vertically between the axial opening 60 and one or both of the side openings 62a, 62b. The break 74 permits the seal holder 58 to spread open as a Luer slip 28 (as opposed to a Luer lock 76 shown in FIG. 17) is inserted into the seal 32. This spreading action has been found to be advantageous for using the valve 20 with a Luer slip 28, as the valve 20 becomes less likely to squeeze or pinch the Luer 28 out of the seal 32.

[0067] FIG. 18 shows an alternative configuration of the housing 30, with a curved or streamlined appearance in comparison to the housing disclosed above. Both this type of housing or the type disclosed above, may have an external coating or layer of a relatively soft, pliant material such as a thermoplastic elastomer to enhance operator comfort and to promote the theme of a valve 20 that provides a connection without the use of sharp, puncturing elements such as needles or blades.

[0068] FIGS. 19A-21 depict a preferred method of making the seal 32. First, a pair of preforms 202a, 202b are molded between first and second mold pairs 204a, 204b and 206a, 206b respectively. Each preform 202 has a generally planar portion 208 that, in the completed seal 32, forms a wall of the slit 38 (see FIGS. 6A-7B). A flange portion 210 is also integrally molded into both preforms 202. The sides of the flange portion 210 are preferably set back from the upper face of the planar portion 208, to provide a space for overmold material (discussed in further detail below) to flow between and connect the flange portions 210. The molding of the preforms 202 is accomplished using conventional techniques and equipment, preferably by injecting a ther-

moset material into the cavity formed between the mold pairs 204a, 204b and 206a, 206b and heating the molds and/or material to the set temperature of the specific material used. Pressure may be applied as needed to prevent material from leaking between the halves of the mold.

[0069] After this initial molding step, the mold halves 204a, 206a, with the preforms 202a, 202b still positioned in them, are pressed together with an overmold plate 212 positioned between the mold halves, as depicted in FIGS. 19B-19C. The overmold plate 212, best seen in FIG. 20 (with the outline of the preforms 202 also shown in phantom), comprises a generally planar plate body 214 with an overmold opening 216 cut into the body 214. The overmold opening 216 has a plan perimeter that conforms to the outer edges of the completed seal 32, and may include a mandrel 218 that projects from the lower portion of the opening 216 and forms the lead lumen 46 (see FIGS. 6A-7B) during the overmold process, as will be discussed in greater detail below. The contacting faces of the mold halves 204a, 206a and the overmold plate 212 are advantageously substantially planar. Thus the mold halves 204a, 206a, plate 212, and preforms 202a, 202b define a mold cavity or volume 220 between the walls of the overmold opening 216 and the outer edges of the preforms 202a, 202b, and between the faces of the mold halves 204a, 206a.

[0070] With the mold apparatus (mold halves 204a, 206a and overmold plate 212) arranged as shown in FIG. 19C, additional thermoset material is injected into the mold apparatus to fill the mold cavity 220 and form the remainder of the seal 32. Preferably, the additional material is injected soon (i.e., a few seconds) after the preforms 202 are molded and while they are still somewhat hot from the initial molding. The additional material injected into the mold cavity 220 bonds to the edges of the preforms 202 and forms the edges of the slit 38 in the completed seal 32. In other words, the remainder of the seal is overmolded onto the "sandwich" of preforms 202. Preferably, the preforms 202 are pressed together with sufficient force during the overmolding process to prevent the additional material from migrating between the contacting surfaces of the preforms 202. This preserves the patency of the slit 38 by preventing the contacting faces of the preforms 202 from bonding to each other during the overmold step.

[0071] The overmold plate 212 may be made with a thickness approximately the same as that of the "sandwich" of preforms 202a, 202b to define a mold cavity 220 that, as described above, comprises the open space between the walls of the overmold opening 216 and the outer edges of the preforms 202a, 202b, and between the faces of the mold halves 204a, 206a. This overmold opening thus also has a thickness approximately equal to that of the preform sandwich, and all or nearly all of the overmold material injected therein bonds only to the edges of the preforms 202a, 202b. In an alternative embodiment, the overmold plate 212 may have a thickness greater than the preform sandwich. This thicker, alternative overmold plate thereby defines a mold cavity that also includes open space that is created between the mold halves 204a, 206a and the outer (i.e., facing away from the slit in the completed seal) faces of the preforms 202a, 202b. The mold halves 204a, 206a are preferably configured with projections, ridges, channels, gaps or the like to create such space during this alternative overmold step while pressing the preforms together as may be needed

during the overmold. Accordingly, in this embodiment the overmold material bonds to both the edges and to the outer faces of the preforms 202a, 202b. In other words this alternative overmold step involves injecting the overmold material into a mold cavity that surrounds most or all of the preform sandwich, rather than overmolding to the only the edges of the preforms.

[0072] It is preferred that the material added in the overmold step is similar to that utilized in molding the preforms 202; however, in other embodiments the preform material and the overmold material may comprise different but nonetheless suitable materials for manufacturing the seal, as discussed above. Therefore as used herein "a flexible material" refers to any material selected from the class of suitable seal materials as disclosed.

[0073] After the overmolding is complete, the mold halves 204a, 206a are removed from the seal plate 212, which now contains a substantially completed seal 32, as seen in FIGS. 19D-19E. The completed seal 32 is easily removed from the seal plate 212, and the seal thus formed comprises, as discussed above, a unitary mass of molded material with the slit arranged within it.

[0074] Although this invention has been disclosed in the context of certain preferred embodiments and examples, it will be understood by those skilled in the art that the present invention extends beyond the specifically disclosed embodiments to other alternative embodiments and/or uses of the invention and obvious modifications and equivalents thereof. Thus, it is intended that the scope of the present invention herein disclosed should not be limited by the particular disclosed embodiments described above, but should be determined only by a fair reading of the claims that follow.

What is claimed is:

1. A medical valve for selectively permitting fluid to flow between a first medical device and a second medical device, the valve comprising:

a housing having an interface suitable for receiving a connector portion of the first medical device, the housing having an upstream end, a downstream end, and an outer surface, the outer surface of the housing being generally cylindrical with a curved profile having a maximum diameter near the upstream end and the downstream end and a minimum diameter between the upstream end and the downstream end, the housing comprising an outer layer of a soft, pliant material disposed over the outer surface; and

a seal element having a downstream end in fluid communication with the interface, an upstream end suitable for receiving the second medical device, and a normally substantially closed passage in fluid communication with the downstream end and the upstream end;

the seal element comprising:

a body made of flexible material and having a downstream end and an upstream end opposite the downstream end;

a lead lumen formed in the downstream end of the body and in fluid communication with the passage;

a neck formed at the upstream end of the body; and

a transverse flange at an end of the neck opposite the body, the transverse flange having at least one opening in fluid communication with the passage.

\* \* \* \* \*