

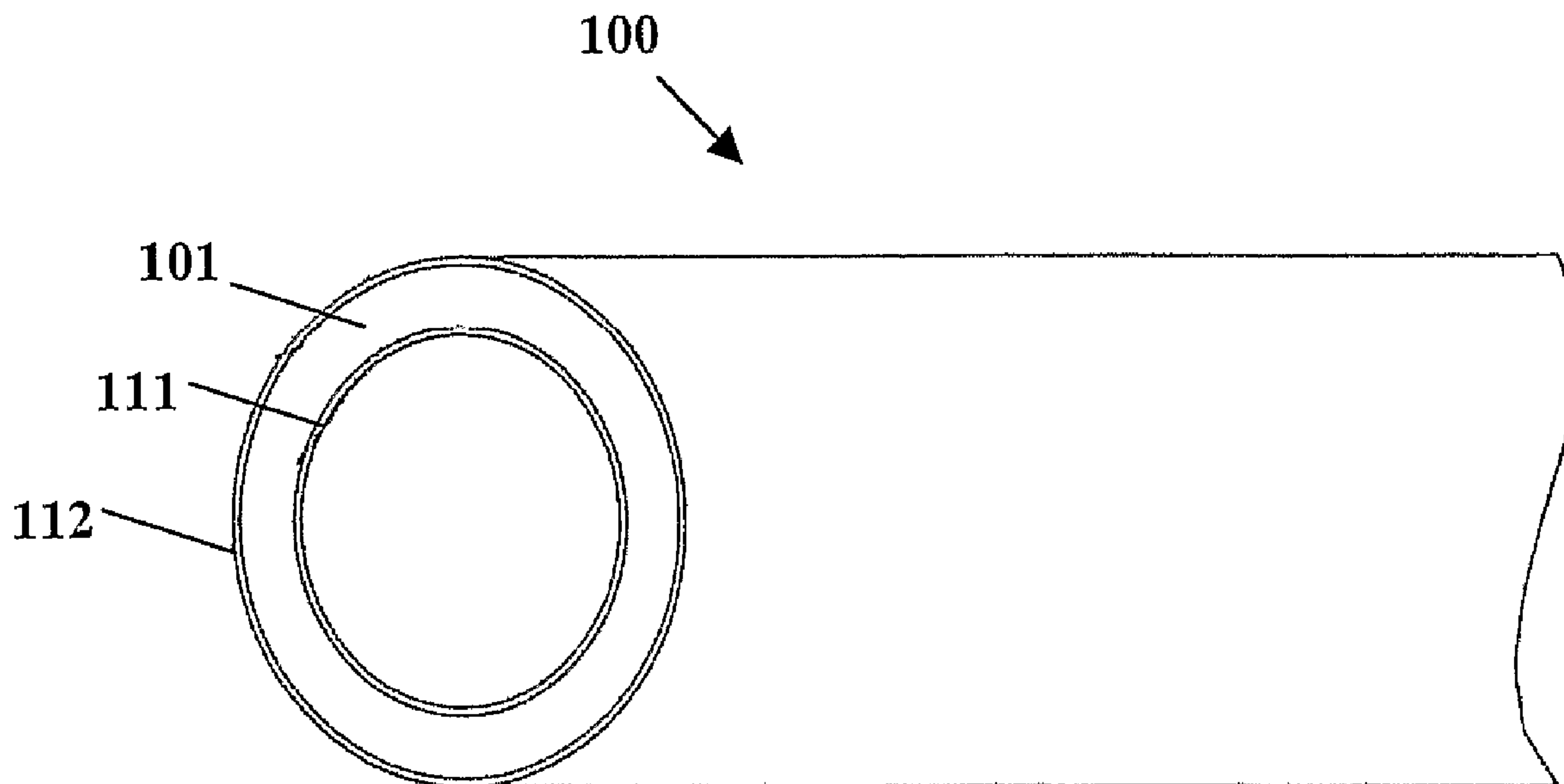

(86) Date de dépôt PCT/PCT Filing Date: 2003/02/07
 (87) Date publication PCT/PCT Publication Date: 2003/08/14
 (45) Date de délivrance/Issue Date: 2012/07/10
 (85) Entrée phase nationale/National Entry: 2004/07/29
 (86) N° demande PCT/PCT Application No.: US 2003/003624
 (87) N° publication PCT/PCT Publication No.: 2003/066119
 (30) Priorité/Priority: 2002/02/08 (US10/071,840)

(51) Cl.Int./Int.Cl. *A61L 27/36* (2006.01),
A61L 2/232 (2006.01), *A61L 29/16* (2006.01),
A61L 31/16 (2006.01)
 (72) Inventeurs/Inventors:
 MILLER, KATHLEEN M., US;
 SYDNEY, GREGORY T., US;
 GEITZ, KURT, US;
 DAYTON, PETER L., US;
 SAHATJIAN, RONALD A., US
 (73) Propriétaire/Owner:
 BOSTON SCIENTIFIC LIMITED, BB
 (74) Agent: KIRBY EADES GALE BAKER

(54) Titre : DISPOSITIF MEDICAL IMPLANTABLE OU INSERABLE RESISTANT A LA CROISSANCE MICROBIENNE ET A LA FORMATION DE BIOFILMS
 (54) Title: IMPLANTABLE OR INSERTABLE MEDICAL DEVICE RESISTANT TO MICROBIAL GROWTH AND BIOFILM FORMATION



(57) Abrégé/Abstract:

Disclosed are implantable or insertable medical devices that provide resistance to microbial growth on and in the environment of the device and resistance to microbial adhesion and biofilm formation on the device. In particular, the invention discloses implantable or insertable medical devices that comprise at least one biocompatible matrix polymer region, an antimicrobial agent for providing resistance to microbial growth and a microbial adhesion/biofilm synthesis inhibitor for inhibiting the attachment of microbes and the synthesis and accumulation of biofilm on the surface of the medical device. Also disclosed are methods of manufacturing such devices under conditions that substantially prevent preferential partitioning of any of said bioactive agents to a surface of the biocompatible matrix polymer and substantially prevent chemical modification of said bioactive agents.



(12) INTERNATIONAL APPLICATION PUBLISHED UNDER THE PATENT COOPERATION TREATY (PCT)

(19) World Intellectual Property Organization
International Bureau(43) International Publication Date
14 August 2003 (14.08.2003)

PCT

(10) International Publication Number
WO 03/066119 A1

- (51) International Patent Classification⁷: A61L 27/36, 29/16, 2/232, 31/16
- (21) International Application Number: PCT/US03/03624
- (22) International Filing Date: 7 February 2003 (07.02.2003)
- (25) Filing Language: English
- (26) Publication Language: English
- (30) Priority Data:
10/071,840 8 February 2002 (08.02.2002) US
- (71) Applicant: SCIMED LIFE SYSTEMS, INC. [US/US];
One Scimed Place, Maple Grove, MN 55331 (US).
- (72) Inventors: MILLER, Kathleen, M.; 93 Brookdale Circle, Shrewsbury, MA 01545 (US). SYDNEY, Gregory, T.; 8 Turning Mill Road, Sharon, MA 02067 (US). GEITZ, Kurt; 143 Maynard Road, Sudbury, MA 01776 (US). DAYTON, Peter, L.; 125 Pleasant Street, #307, Brookline, MA 02446 (US). SAHATJIAN, Ronald, A.; 29 Saddle Club Road, Lexington, MA 02420 (US).
- (74) Agent: BONHAM, David, B.; Mayer Fortkort & Williams, PC, 2nd Floor, 251 North Avenue West, Westfield, NJ 07090 (US).
- (81) Designated States (*national*): AE, AG, AL, AM, AT, AU, AZ, BA, BB, BG, BR, BY, BZ, CA, CH, CN, CO, CR, CU, CZ, DE, DK, DM, DZ, EC, EE, ES, FI, GB, GD, GE, GH, GM, HR, HU, ID, IL, IN, IS, JP, KE, KG, KP, KR, KZ, LC, LK, LR, LS, LT, LU, LV, MA, MD, MG, MK, MN, MW, MX, MZ, NO, NZ, OM, PH, PL, PT, RO, RU, SC, SD, SE, SG, SK, SL, TJ, TM, TN, TR, TT, TZ, UA, UG, UZ, VC, VN, YU, ZA, ZM, ZW.
- (84) Designated States (*regional*): ARIPO patent (GH, GM, KE, LS, MW, MZ, SD, SL, SZ, TZ, UG, ZM, ZW), Eurasian patent (AM, AZ, BY, KG, KZ, MD, RU, TJ, TM), European patent (AT, BE, BG, CH, CY, CZ, DE, DK, EE, ES, FI, FR, GB, GR, HU, IE, IT, LU, MC, NL, PT, SE, SI, SK, TR), OAPI patent (BF, BJ, CF, CG, CI, CM, GA, GN, GQ, GW, ML, MR, NE, SN, TD, TG).
- Published:**
— with international search report
— before the expiration of the time limit for amending the claims and to be republished in the event of receipt of amendments

[Continued on next page]

(54) Title: IMPLANTABLE OR INSERTABLE MEDICAL DEVICE RESISTANT TO MICROBIAL-GROWTH AND BIOFILM FORMATION

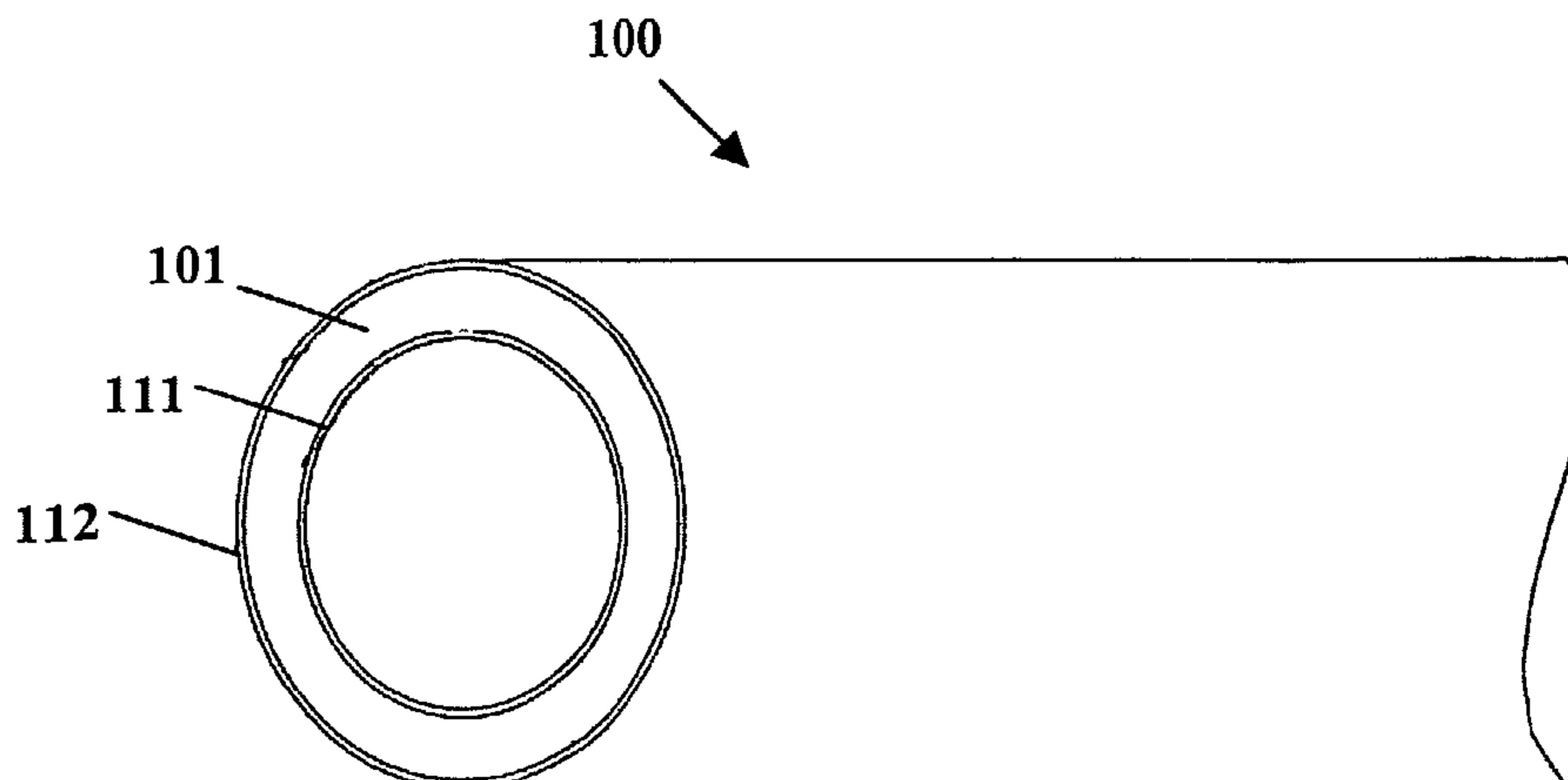

(57) Abstract: Disclosed are implantable or insertable medical devices that provide resistance to microbial growth on and in the environment of the device and resistance to microbial adhesion and biofilm formation on the device. In particular, the invention discloses implantable or insertable medical devices that comprise at least one biocompatible matrix polymer region, an antimicrobial agent for providing resistance to microbial growth and a microbial adhesion/biofilm synthesis inhibitor for inhibiting the attachment of microbes and the synthesis and accumulation of biofilm on the surface of the medical device. Also disclosed are methods of manufacturing such devices under conditions that substantially prevent preferential partitioning of any of said bioactive agents to a surface of the biocompatible matrix polymer and substantially prevent chemical modification of said bioactive agents.



WO 03/066119 A1

WO 03/066119 A1



For two-letter codes and other abbreviations, refer to the "Guidance Notes on Codes and Abbreviations" appearing at the beginning of each regular issue of the PCT Gazette.

**IMPLANTABLE OR INSERTABLE MEDICAL DEVICE RESISTANT TO
MICROBIAL GROWTH AND BIOFILM FORMATION**

FIELD OF THE INVENTION

[0001] The present invention relates to implantable or insertable medical devices that provide resistance to microbial growth on and in the environment of the device and resistance to microbial adhesion and biofilm formation on the device. In another aspect, the present invention relates to methods of manufacturing such implantable or insertable medical devices, particularly to methods of manufacturing such devices that comprise at least one matrix polymer region, an antimicrobial agent for providing resistance to microbial growth and a microbial adhesion/biofilm synthesis inhibitor for inhibiting the attachment of microbes and the synthesis and accumulation of biofilm on the surface of the medical device.

BACKGROUND OF THE INVENTION

[0002] Implantable or insertable medical devices such as stents made of metallic, polymeric or a composite of metallic and polymeric materials frequently occlude due to microbial colonization and adhesion. This problem is particularly prevalent with medical devices that are adapted to remain implanted for a relatively long-term, i.e., from about 30 days to about 12 months or longer. Microbes such as bacteria often colonize on and around the medical device and, upon attaching to surfaces of the device, proliferate and form aggregates within a complex matrix consisting of extracellular polymeric substances, typically polysaccharides. The mass of attached microorganisms and the associated extracellular polymeric substances is commonly referred to as a biofilm or slime. Antimicrobial agents have difficulty penetrating biofilms and killing and/or

inhibiting the proliferation of the microorganisms within the biofilm. The colonization of the microbes on and around the device and the synthesis of the biofilm barrier eventually result in encrustation, occlusion and failure of the device.

[0003] Previous approaches to minimize this problem have included the use of low surface energy materials such as Teflon® in implantable medical devices and the use of surface coatings on such medical devices. Surface coatings have typically comprised single antimicrobials or 1-2 antibiotics.

[0004] For example, U.S. Patent No. 5,853,745 discloses an implantable medical device having a durable protective coating layer over an antimicrobial coating layer. The coating layers are formed by applying an antimicrobial coating layer to at least a portion of the surface of the medical device, applying a durable coating over the antimicrobial coating layer, and applying a resilient coating layer over the durable coating layer.

[0005] U.S. Patent No. 5,902,283 discloses a non-metallic antimicrobial impregnated implantable medical device where the antimicrobial composition is applied to the device under conditions where the antimicrobial composition permeates the material of the device.

[0006] U.S. Patent No. 5,772,640 discloses polymeric medical devices that have been impregnated and/or coated with chlorhexidine and triclosan by dipping or soaking the medical device in a solution of a hydrophobic or hydrophilic polymer containing chlorhexidine and triclosan.

[0007] Published International Application No. WO 99/47595 discloses a plastics material that can be used in certain medical applications comprising an acrylic polymer containing 5-50% of a rubbery copolymer and a biocidal compound. The patent also

discloses adding antimicrobial agent to the polymer melt by means of a liquid injection system.

[0008] U.S. Patent No. 5,679,399 discloses membranes that may include one or more permeable or semipermeable layers containing substances such as biocides. The layers allow the transmission of environmental fluids inwardly and the outward dispersion of the biocides. These membranes may also include a sealing or coating to entrap agents such as biocides therein.

[0009] Of the previous approaches, coatings have met with the greatest success because of their proximity to the bacterial environment and hence their active approach to preventing bacterial colonization and attachment. However, this approach has proven inadequate because of the potential for bacterial resistance to a single narrow spectrum active agent, because the amount of active agent that can be incorporated into such coatings is typically low, and because externally coated tubular devices release active agents to the environment external to the device but not intraluminally.

[0010] In an effort to alleviate the foregoing and other disadvantages of the prior art, Applicants have developed an implantable or insertable medical device suitable for long-term implantation and a method for manufacturing such a device, wherein the device provides resistance to microbial growth on and around the device and biofilm formation on the device. The device of the present invention, therefore, overcomes the disadvantages associated with the use of coatings as discussed above, and provides a reduced risk of biofilm fouling that eventually results in encrustation, occlusion and failure of the device.

SUMMARY OF THE INVENTION

[0011] One aspect of the present invention is directed to an implantable medical device comprising at least one biocompatible matrix polymer region and bioactive agents comprising an antimicrobial agent and a microbial attachment/biofilm synthesis inhibitor. In one particular embodiment the device comprises a multilayer structure formed by coextrusion. In some preferred embodiments, the medical device comprises multiple distinct matrix polymer regions. One or more barrier layers at least partially covering a matrix polymer region may also be provided in preferred embodiments of the present invention. Preferred antimicrobial agents include triclosan, chlorhexidine and salts or combinations thereof. Other antimicrobial agents include, but are not limited to nitrofurazone, benzalkonium chlorides, silver salts and antibiotics such as rifampin, gentamycin and minocyclin. Preferred microbial attachment/biofilm synthesis inhibitors include salicylic acid and salts and derivatives thereof. A radio-opacifying agent is preferably included in a matrix polymer region, and one or more therapeutic agents may also be present. The matrix polymer and any barrier layer may preferably comprise a biodegradable or substantially non-biodegradable material such as an ethylene vinyl acetate copolymer, copolymers of ethylene with acrylic acid or methacrylic acid; metallocene catalyzed polyethylenes and polyethylene copolymers, ionomers, elastomeric materials such as elastomeric polyurethanes and polyurethane copolymers, silicones and mixtures thereof. Among medical devices in accordance with the present invention are biliary, ureteral and pancreatic stents, stent covers, catheters, venous access devices and devices bridging or providing drainage between a sterile and non-sterile body environment or between two sterile body environments. Pancreatic stents that release a buffering agent are among preferred pancreatic stents.

[0012] In another aspect, the present invention is directed to a method of manufacturing an implantable or insertable medical device comprising providing one or more biocompatible matrix polymers and bioactive agents comprising an antimicrobial agent and a microbial attachment/biofilm synthesis inhibitor; processing the one or more biocompatible matrix polymers and the bioactive agents under conditions that substantially prevent preferential partitioning of any of the bioactive agents to a surface of any of the biocompatible matrix polymers and substantially prevent chemical modification of the bioactive agents. Processing preferably comprises forming a homogenous mixture of the matrix polymer and any bioactive agent and optional radio-opacifying agent and/or therapeutic agent and shaping the homogeneous mixture into at least a portion of an implantable or insertable medical device. Among preferred shaping processes are included extrusion and coextrusion for multiple layer structures.

BRIEF DESCRIPTION OF THE DRAWINGS

[0013] Fig. 1 is a simplified schematic representation (perspective view) of a portion of an implantable or insertable medical device in accordance with an embodiment of the present invention.

[0014] Fig. 2 is a simplified schematic representation (perspective view) of a portion of an implantable or insertable medical device in accordance with an embodiment of the present invention.

[0015] Fig. 3 is a graph showing bacterial attachment inhibition onto extruded tubes containing varying amounts of triclosan (TCN) and salicylic acid (SA).

[0016] Fig. 4 is a graph showing bacterial attachment inhibition onto extruded tubes containing varying amounts of triclosan (TCN) and salicylic acid (SA).

[0017] Fig. 5 is a graph showing the zone of bacterial (*E. coli* ATCC 25922) growth inhibition around extruded tubes containing varying amounts of triclosan (TCN) and salicylic acid (SA).

[0018] Fig. 6 is a graph showing the zone of bacterial (coagulase negative staph #99) growth inhibition around extruded tubes containing varying amount of triclosan and salicylic acid (SA).

[0019] As is typically the case with such figures, Figs. 1 and 2 are simplified schematic representations presented for purposes of illustration only, and the actual structures may differ in numerous respects including the relative scale of the components.

DETAILED DESCRIPTION OF THE INVENTION

[0020] In one aspect, the present invention is directed to an implantable or insertable medical device comprising at least one biocompatible matrix polymer region, as well as multiple bioactive components, which comprise an antimicrobial agent and a microbial attachment/biofilm synthesis inhibitor.

[0021] The term “biocompatible” as used herein describes a material that is substantially not toxic to the human body, and that does not significantly induce inflammation or other adverse response in body tissues.

[0022] The term “matrix polymer” as used herein refers to a polymeric material that forms at least a portion or region of the implantable or insertable medical device of the present invention. The matrix polymer is selected to be biocompatible and provide mechanical properties consistent with the intended function and operation of the implantable or insertable medical device. The matrix polymer also serves as a repository in which at least one and, in some preferred embodiments, both the antimicrobial agent

and microbial attachment/biofilm synthesis inhibitor are dispersed and/or dissolved. The matrix polymer may also contain, as optional components, a radio-opacifying agent and/or one or more therapeutic agents.

[0023] The term “antimicrobial agent” as used herein means a substance that kills and/or inhibits the proliferation and/or growth of microbes, particularly bacteria, fungi and yeast. Antimicrobial agents, therefore, include biocidal agents and biostatic agents as well as agents that possess both biocidal and biostatic properties. In the context of the present invention, the antimicrobial agent kills and/or inhibits the proliferation and/or growth of microbes on and around the surfaces of an implanted medical device.

[0024] The term “microbial attachment/biofilm synthesis inhibitor” as used herein means a substance that inhibits the attachment of microbes onto a surface and the ability of such microbes to synthesize and/or accumulate biofilm on a surface. In the context of the present invention, such a surface includes a surface of an implantable medical device exposed to a physiological environment, such as a physiological fluid, that may be conducive to the formation and accumulation of biofilm on the surface of the medical device. The microbial attachment/biofilm synthesis inhibitor may also have substantial antimicrobial activity as described herein. Likewise, the antimicrobial agent may also have substantial ability to inhibit microbial attachment/biofilm synthesis.

[0025] By “biofilm” is meant the mass of microorganisms attached to a surface, such as a surface of a medical device, and the associated extracellular substances produced by one or more of the attached microorganisms. The extracellular substances are typically polymeric substances and commonly comprise a matrix of complex polysaccharides, proteinaceous substances and glycopeptides. This matrix or biofilm is also commonly referred to as “glycocalyx.”

[0026] Biofilm formation on the surfaces of implantable or insertable medical devices adapted for long-term implantation, e.g., from about 30 days to 12 months or longer, can result in eventual encrustation and failure of the device. Further, the proliferation of microbes within the biofilm can lead to localized infections as well as difficult to treat systemic infections. The extracellular substances that comprise the biofilm matrix can act as a barrier that protects and isolates the microorganisms housed in the biofilm from normal immunological defense mechanisms, such as antibodies and phagocytes, as well as from antimicrobial agents including surfactants, biocides and antibiotics. The biofilm also facilitates the growth and proliferation of microbes housed within the biofilm.

[0027] The present invention substantially reduces the risk of biofilm accumulation on the surfaces of a medical device adapted for long term implantation, and the resultant likelihood of premature failure of the device due to encrustation and occlusion by such biofilm. In some preferred embodiments of the present invention, the medical device is intended to remain implanted for a relatively long period of from about 30 days to about 12 months or longer. However, it is understood that the device may be implanted for a period of 30 days or shorter as well.

[0028] The biocompatible matrix polymer of the device of the present invention is provided to serve as a repository in which the antimicrobial agent, the microbial attachment/biofilm synthesis inhibitor, or both, are dispersed and/or dissolved. The medical device of the present invention will preferably contain at least one matrix polymer which forms at least a single distinct portion or region of the medical device. Where only a single distinct matrix polymer region is provided in the medical device, the matrix polymer will preferably contain both the antimicrobial agent and the microbial

attachment/biofilm synthesis inhibitor. However, in other preferred embodiments, the medical device will comprise two or more distinct matrix polymer regions. Where two or more distinct matrix polymer regions are present in the medical device, it is not necessary that both the antimicrobial agent and the microbial attachment/biofilm synthesis inhibitor be present in any single one of such multiple matrix polymer regions. Thus, the antimicrobial agent may be present in a first matrix polymer region and the microbial attachment/biofilm synthesis inhibitor may be present in a second matrix polymer region distinct from the first matrix polymer region. However, it is understood that both bioactive agents may be present in one or all of any distinct matrix polymer regions. Further, as discussed more fully below, where multiple distinct matrix polymer regions are present, the regions may be separated by barrier layers that at least partially cover a surface of the matrix polymer region.

[0029] The amount of the antimicrobial agent present in a matrix polymer is preferably an amount effective to kill and/or inhibit the growth of microbes on and around the implanted medical device. Preferred amounts of the antimicrobial agent present in the matrix polymer range from about 0.5% to about 25% by weight of the matrix polymer. Amounts of from about 10% to about 25% by weight of the matrix polymer are particularly preferred.

[0030] The amount of the microbial attachment/biofilm synthesis inhibitor present in a matrix polymer is preferably an amount effective to inhibit the attachment of microbes onto and the synthesis and/or accumulation of biofilm by attached microbes on a surface of the implanted medical device. Preferred amounts of the antimicrobial agent present in the matrix polymer range from about 0.5% to about 25% by weight of the matrix

polymer. Amounts of from about 10% to about 25% by weight of the matrix polymer are particularly preferred.

[0031] The amount of antimicrobial agent and/or microbial attachment/biofilm synthesis inhibitor present in a matrix polymer will depend on, *inter alia*, on the efficacy of the bioactive agent employed, the length of time during which the medical device is intended to remain implanted, as well as the rate at which the matrix polymer or barrier layer releases the bioactive agent in the environment of the implanted medical device. Thus, a device that is intended to remain implanted for a longer period will generally require a higher percentage of the antimicrobial agent and/or microbial attachment/biofilm synthesis inhibitor. Similarly, a matrix polymer that provides faster release of the bioactive agent may require a higher amount of the bioactive agent. The amount of bioactive agent in the matrix polymer may be limited, of course, by the propensity for such bioactive agent to cause undesirable localized or systemic toxic reaction and by the potential impairment of the mechanical properties necessary for the proper functioning of the medical device.

[0032] In many instances, it is believed that the bioactive agent is released, at least in part, from a non-biodegradable matrix polymer region by a mechanism wherein the matrix polymer imbibes or contacts physiological fluid. The physiological fluid dissolves or disperses the bioactive agent reposed within the matrix, and the dissolved or dispersed bioactive agent then diffuses outwardly from the matrix polymer into the physiological environment where the device is implanted. Matrix polymers need not be permeable to aqueous fluids such as physiological fluids to provide release of bioactive agent. Matrix polymers with low permeability to aqueous fluids may adsorb such fluids at a surface of the polymer. In such matrix polymers, a concentration gradient is believed to be set up at

the surface of the polymer and the bioactive agent is released via diffusion based on its solubility in the solid polymer relative to its solubility in the fluid or aqueous phase.

Where the matrix polymer is biodegradable, similar diffusion processes may also occur.

In a biodegradable matrix polymer, bioactive agent may also be released as the biodegradable matrix polymer containing the reposed bioactive agent biodegrades upon contact with the physiological environment where the device is implanted. Thus, in a biodegradable polymer, bioactive agent may be released by diffusional processes and upon biodegradation of the polymer matrix.

[0033] The antimicrobial agent present in the matrix polymer can be any pharmaceutically acceptable antimicrobial agent. By "pharmaceutically acceptable" as used herein is meant an agent that is approved or capable of being approved by the United States Food and Drug Administration or Department of Agriculture as safe and effective for use in humans or animals when incorporated in or on an implantable or insertable medical device. Preferred antimicrobial agents include, but are not limited to, triclosan, chlorhexidine, nitrofurazone, benzalkonium chlorides, silver salts and antibiotics such as rifampin, gentamycin and minocyclin and combinations thereof.

[0034] The microbial attachment/biofilm synthesis inhibitor can be any pharmaceutically acceptable agent that inhibits the attachment of microbes onto and the synthesis and/or accumulation of biofilm on a surface of an implantable or insertable medical device. Among preferred microbial attachment/biofilm synthesis inhibitors include, but are not limited to, non-steroidal anti-inflammatory drugs (NSAIDs) and chelating agents such as EDTA (ethylenediaminetetraacetic acid), EGTA (O,O'-bis(2-aminoethyl)ethyleneglycol-N,N,N',N'-tetraacetic acid) and mixtures thereof. Among preferred NSAIDs are salicylic acid and salts and derivatives thereof. Preferred salts of

salicylic acid include, but are not limited to, sodium salicylate and potassium salicylate.

Sodium salicylate is a particularly preferred salt for use as the microbial attachment/biofilm synthesis inhibitor. Salicylic acid is a particularly preferred microbial attachment/biofilm synthesis inhibitor.

[0035] Some preferred combinations of antimicrobial agent and microbial attachment/biofilm synthesis inhibitors present in a medical device in accordance with the present invention comprise triclosan and/or chlorhexidine in combination with salicylic acid or a salt thereof such as sodium salicylate. The combination of triclosan and salicylic acid or a salt thereof is particularly preferred.

[0036] The presence of both an antimicrobial agent and a microbial attachment/biofilm synthesis inhibitor in a medical device in accordance with the present invention provides distinct advantages over the use of, for example, only an antimicrobial agent. The use of such a dual mechanism for preventing microbial colonization and attachment is believed to have a synergistic effect. The synergy is related to the different mechanism of action of each of the bioactive agents. The antimicrobial agent not only kills a large percentage of microbes approaching a surface of the device, it also reduces the burden of microbes upon which the microbial attachment/biofilm synthesis inhibitor must act. Moreover, microbes that have attached to a surface produce a protective biofilm barrier after attachment. This biofilm barrier prevents or reduces the ability of antimicrobial agents from reaching the microbes. The antimicrobial agent is thereby rendered substantially less effective upon formation of the biofilm barrier. Therefore, if microbial attachment is prevented, biofilm synthesis is inhibited and the antimicrobial agent is rendered more effective.

[0037] The matrix polymer used in the implantable or insertable medical device of

the present invention may be any biocompatible polymer suitable for use in implantable or insertable medical devices. The matrix polymer may be substantially non-biodegradable or biodegradable.

[0038] Preferred substantially non-biodegradable biocompatible matrix polymers include thermoplastic and elastomeric polymeric materials. Polyolefins such as metallocene catalyzed polyethylenes, polypropylenes, and polybutylenes and copolymers thereof; vinyl aromatic polymers such as polystyrene; vinyl aromatic copolymers such as styrene-isobutylene copolymers and butadiene-styrene copolymers; ethylenic copolymers such as ethylene vinyl acetate (EVA), ethylene-methacrylic acid and ethylene-acrylic acid copolymers where some of the acid groups have been neutralized with either zinc or sodium ions (commonly known as ionomers); polyacetals; chloropolymers such as polyvinylchloride (PVC); fluoropolymers such as polytetrafluoroethylene (PTFE); polyesters such as polyethyleneterephthalate (PET); polyester-ethers; polyamides such as nylon 6 and nylon 6,6; polyamide ethers; polyethers; elastomers such as elastomeric polyurethanes and polyurethane copolymers; silicones; polycarbonates; and mixtures and block or random copolymers of any of the foregoing are non-limiting examples of non-biodegradable biocompatible matrix polymers useful for manufacturing the medical devices of the present invention.

[0039] Among particularly preferred non-biodegradable polymeric materials are polyolefins, ethylenic copolymers including ethylene vinyl acetate copolymers (EVA) and copolymers of ethylene with acrylic acid or methacrylic acid; elastomeric polyurethanes and polyurethane copolymers; metallocene catalyzed polyethylene (mPE), mPE copolymers, ionomers, and mixtures and copolymers thereof; and vinyl aromatic polymers and copolymers. Among preferred vinyl aromatic copolymers are included

copolymers of polyisobutylene with polystyrene or polymethylstyrene, even more preferably polystyrene-polyisobutylene-polystyrene triblock copolymers. These polymers are described, for example, in U.S. Patent No. 5,741,331, U.S. Patent No. 4,946,899 and U.S. 2002/0107330. Ethylene vinyl acetate having a vinyl acetate content of from about 19% to about 28% is an especially preferred non-biodegradable material. EVA copolymers having a lower vinyl acetate content of from about 3% to about 15% are also useful in particular embodiments of the present invention as are EVA copolymers having a vinyl acetate content as high as about 40%. These relatively higher vinyl acetate content copolymers may be beneficial in offsetting stiffness from coextruded barrier layers. Among preferred elastomeric polyurethanes are block and random copolymers that are polyether based, polyester based, polycarbonate based, aliphatic based, aromatic based and mixtures thereof. Commercially available polyurethane copolymers include, but are not limited to, Carbothane®, Tecoflex®, Tecothane®, Tecophilic®, Tecoplast®, Pellethane®, Chronothane® and Chronoflex®. Other preferred elastomers include polyester-ethers, polyamide-ethers and silicone.

[0040] Among preferred biodegradable matrix polymers are included, but not limited to, polylactic acid, polyglycolic acid and copolymers and mixtures thereof such as poly(L-lactide) (PLLA), poly(D,L-lactide) (PLA); polyglycolic acid [polyglycolide (PGA)], poly(L-lactide-co-D,L-lactide) (PLLA/PLA), poly(L-lactide-co-glycolide) (PLLA/PGA), poly(D, L-lactide-co-glycolide) (PLA/PGA), poly(glycolide-co-trimethylene carbonate) (PGA/PTMC), poly(D,L-lactide-co-caprolactone) (PLA/PCL), poly(glycolide-co-caprolactone) (PGA/PCL); polyethylene oxide (PEO), polydioxanone (PDS), polypropylene fumarate, poly(ethyl glutamate-co-glutamic acid), poly(tert-

butyloxy-carbonylmethyl glutamate), polycaprolactone (PCL), polycaprolactone co-butylacrylate, polyhydroxybutyrate (PHBT) and copolymers of polyhydroxybutyrate, poly(phosphazene), poly(phosphate ester), poly(amino acid) and poly(hydroxy butyrate), polydepsipeptides, maleic anhydride copolymers, polyphosphazenes, polyiminocarbonates, poly[(97.5% dimethyl-trimethylene carbonate)-co-(2.5% trimethylene carbonate)], cyanoacrylate, polyethylene oxide, hydroxypropylmethylcellulose, polysaccharides such as hyaluronic acid, chitosan and regenerate cellulose, and proteins such as gelatin and collagen, and mixtures and copolymers thereof, among others.

[0041] Particularly preferred biodegradable polymers comprise polylactic acid, polyglycolic acid and copolymers and mixtures thereof.

[0042] The medical device of the present invention may also contain a radio-opacifying agent within its structure. For example, the radio-opacifying agent may be present in or on any of the matrix polymer regions or in or on an optional barrier layer that at least partially covers a surface of a matrix polymer region. Barrier layers are described more fully below. The radio-opacifying agent facilitates viewing of the medical device during insertion of the device and at any point while the device is implanted. A radio-opacifying agent typically functions by scattering x-rays. The areas of the medical device that scatter the x-rays are detectable on a radiograph. Among radio-opacifying agents useful in the medical device of the present invention are included, but not limited to, bismuth subcarbonate, bismuth oxychloride, bismuth trioxide, barium sulfate, tungsten and mixtures thereof. Where present, the radio-opacifying agent is preferably present in an amount of from about 0.5% to about 90%, more preferably from about 10% to about 90% by weight, of the matrix polymer. A particularly preferred

amount of radio-opacifying agent is from about 10 to about 40% by weight of the matrix polymer.

[0043] The medical device of the present invention may also contain one or more therapeutic agents within its structure. For example, any therapeutic agent may be present in or on any of the matrix polymer regions or in or on any optional barrier layer that at least partially covers a surface of a matrix polymer region. The therapeutic agent may be any pharmaceutically acceptable agent. A therapeutic agent includes genetic therapeutic agents, non-genetic therapeutic agents and cells.

[0044] Exemplary non-genetic therapeutic agents include: (a) anti-thrombotic agents such as heparin, heparin derivatives, urokinase, and PPACK™ (dextrophenylalanine proline arginine chloromethylketone); (b) steroidal and non-steroidal anti-inflammatory agents (NSAIDs) such as dexamethasone, prednisolone, corticosterone, hydrocortisone and budesonide estrogen, sulfasalazine and mesalamine, salicylic acid and salts and derivatives thereof, ibuprofen, naproxen, sulindac, diclofenac, piroxicam, ketoprofen, diflunisal, nabumetone, etodolac, oxaprozin and indomethacin;

[0045] (c) chemotherapeutic agents such as antineoplastic/antiproliferative/anti-mitotic agents including paclitaxel, 5-fluorouracil, cisplatin, vinblastine, vincristine, epothilones, endostatin, angiostatin, doxorubicin, methotrexate, angiopentin, monoclonal antibodies capable of blocking smooth muscle cell proliferation, and thymidine kinase inhibitors; (d) anesthetic agents such as lidocaine, bupivacaine and ropivacaine; (e) anti-coagulants such as D-Phe-Pro-Arg chloromethyl ketone, an RGD peptide-containing compound, heparin, hirudin, antithrombin compounds, platelet receptor antagonists, anti-thrombin antibodies, anti-platelet receptor antibodies, aspirin, prostaglandin inhibitors, platelet inhibitors and tick antiplatelet peptides; (f) vascular cell growth promoters such as

growth factors, transcriptional activators, and translational promoters; (g) vascular cell growth inhibitors such as growth factor inhibitors, growth factor receptor antagonists, transcriptional repressors, translational repressors, replication inhibitors, inhibitory antibodies, antibodies directed against growth factors, bifunctional molecules consisting of a growth factor and a cytotoxin, bifunctional molecules consisting of an antibody and a cytotoxin; (h) protein kinase and tyrosine kinase inhibitors (e.g., tyrphostins, genistein, quinoxalines); (i) prostacyclin analogs; (j) cholesterol-lowering agents; (k) angiopoietins; (l) antimicrobial agents such as triclosan, cephalosporins, β -lactams, aminoglycosides and nitrofurantoin; (m) chemotherapeutic agents such as cytotoxic agents, cytostatic agents and cell proliferation affectors; (n) vasodilating agents; and (o) agents that interfere with endogenous vasoactive mechanisms.

[0046] Exemplary genetic therapeutic agents include anti-sense DNA and RNA as well as DNA coding for: (a) anti-sense RNA, (b) tRNA or rRNA to replace defective or deficient endogenous molecules, (c) angiogenic factors including growth factors such as acidic and basic fibroblast growth factors, vascular endothelial growth factor, epidermal growth factor, transforming growth factor α and β , platelet-derived endothelial growth factor, platelet-derived growth factor, tumor necrosis factor α , hepatocyte growth factor and insulin-like growth factor, (d) cell cycle inhibitors including CD inhibitors, and (e) thymidine kinase ("TK") and other agents useful for interfering with cell proliferation. Also of interest is DNA encoding for the family of bone morphogenic proteins ("BMP's"), including BMP-2, BMP-3, BMP-4, BMP-5, BMP-6 (Vgr-1), BMP-7 (OP-1), BMP-8, BMP-9, BMP-10, BMP-11, BMP-12, BMP-13, BMP-14, BMP-15, and BMP-16. Currently preferred BMP's are any of BMP-2, BMP-3, BMP-4, BMP-5, BMP-6 and BMP-7. These dimeric proteins can be provided as homodimers, heterodimers, or

combinations thereof, alone or together with other molecules. Alternatively, or in addition, molecules capable of inducing an upstream or downstream effect of a BMP can be provided. Such molecules include any of the "hedgehog" proteins, or the DNA's encoding them.

[0047] Vectors of interest for delivery of genetic therapeutic agents include (a) plasmids, (b) viral vectors such as adenovirus, adenoassociated virus and lentivirus, and (c) non-viral vectors such as lipids, liposomes and cationic lipids.

[0048] Cells include cells of human origin (autologous or allogeneic), including stem cells, or from an animal source (xenogeneic), which can be genetically engineered if desired to deliver proteins of interest.

[0049] Among preferred therapeutic agents that may optionally be present in a medical device of the present invention include, but are not limited to, steroidal and non-steroidal anti-inflammatory agents (NSAIDs) and chemotherapeutic agents such as antineoplastic/antiproliferative/anti-mitotic agents, cytotoxic agents, cytostatic agents and cell proliferation affectors. Examples of chemotherapeutic agents include cisplatin, methotrexate, doxorubicin, paclitaxel and docetaxel. Examples of steroidal anti-inflammatory agents include dexamethasone, hydrocortisone and prednisone.

[0050] The therapeutic agent may be applied onto or into the device or any portion thereof (the matrix polymer region or any optional barrier layer, for example) by contacting the device or portion thereof with a solution or suspension of the therapeutic agent, for example by spraying, dipping, and so forth, followed by evaporating the solvent or carrier liquid. The drug may also be incorporated during the processing and/or shaping of any of the matrix polymers and/or optional polymeric barrier layers used to form the medical device of the present invention provided that the drug is stable at the

conditions (e.g., temperature and pressure) required during such processing and/or shaping.

[0051] The amount of the therapeutic agent will be a therapeutically effective amount. As with the antimicrobial agent and microbial attachment/biofilm synthesis inhibitor, the amount of any therapeutic agent present in a medical device will depend, *inter alia*, on the particular therapeutic agent, the length of time during which the medical device is intended to remain implanted, and the rate at which the therapeutic agent is released from the matrix polymer and/or barrier layer. The amount of the therapeutic agent may be limited by the propensity of such agent to cause an undesirable localized or systemic toxic reaction and by the impairment of mechanical properties necessary for proper functioning of the device.

[0052] The medical device of the present invention may comprise a multilayer structure comprising from 2 to about 50 distinct layers, more preferably from about 2 to about 20 layers formed by coextrusion as described more fully below. Preferred multilayer structures may have from about 2 to about 7 distinct layers. Particularly preferred multilayer structures have from about 3 to about 7 layers, with a 3 layer construction being especially preferred. As noted above, the medical device comprises one or more matrix polymer regions. The medical device can also comprise one or more barrier regions as well. Hence, in a multilayer construction, one or more of the distinct layers may be a barrier layer that least partially covers one or more matrix polymer layers. Thus, the medical device of the present invention may comprise one or more layers comprising one or more distinct matrix polymer layers and, if desired, one or more barrier layers.

[0053] Multilayer structures of the present invention need not comprise a barrier

layer. For example, a medical device in accordance with the present invention may comprise a two-layer structure comprising a first matrix polymer layer containing the bioactive agents and radio-opacifying agent and a second layer on an external surface of the first matrix polymer layer wherein the second layer provides lubricity. Such a lubricious layer may be desirable, for example, to facilitate insertion and implantation of the medical device.

[0054] It is understood that the medical device of the present invention is not limited to a multiple layer structure and, indeed, a single layer structure such as an annular tube comprising a matrix polymer, an antimicrobial agent, a microbial attachment/biofilm synthesis inhibitor and an optional radio-opacifying agent, is within the scope of the present invention.

[0055] Medical devices in accordance with the present invention having multiple layer structures may provide certain advantages relative to single layer devices, however. For example, a barrier layer can be provided to control the rate of release of bioactive material or therapeutic agent from an adjacent layer, such a matrix polymer layer. The barrier layer, as described more fully below, may also be advantageous in substantially reducing the partitioning of a bioactive agent to the surface of a matrix polymer layer during processing. Multiple layers, such as distinct matrix polymer layers, may also act as reservoirs for different bioactive agents and/or combinations of a bioactive agent, a radio-opaque material and a therapeutic agent. Hence, the use of multiple layers may be advantageous in providing different release profiles of different bioactive agents and/or therapeutic agents. For example, the release characteristics of a particular bioactive and/or therapeutic agent may depend on its ability to diffuse from a particular matrix polymer. Thus, different compositions of matrix polymer and bioactive and/or

therapeutic agent may provide different release characteristics therefrom. Some compositions may result in relatively fast release while others may result in a relatively slower release profile. By appropriate selection and arrangement of distinct layers of matrix polymer containing bioactive and/or therapeutic agents, the release profile of the different bioactive and/or therapeutic agent from the device may be optimized for a particular application.

[0056] For example, in one embodiment of the present invention adapted to provide controlled release of a bioactive and any optional therapeutic agents, there is provided a multilayer structure comprising a first annular layer comprising a biocompatible matrix polymer, an antimicrobial agent, a microbial attachment/biofilm synthesis inhibitor and, optionally, a therapeutic agent. First and second barrier layers (also annular in shape) are disposed on the exterior and interior surfaces, respectively, of the first annular layer. The first and second barrier layers that enclose the first annular layer are typically less permeable than the biocompatible matrix polymer and, thereby, control the rate of diffusion of the bioactive and optional therapeutic agents from the device to the external environment.

[0057] A simplified schematic representation of this embodiment of the present invention is depicted in Fig. 1. Implantable or insertable medical device **100** in accordance with this embodiment of the present invention comprises an annular first matrix polymer region **101**; an annular first polymeric barrier layer **111** at least partially covering an interior surface of first matrix polymer region **101** and, an annular second polymeric barrier layer **112** at least partially covering an exterior surface of first matrix polymer region **101**. Annular first and second polymeric barrier layers **111** and **112**, respectively, may have the same or a different composition.

[0058] The barrier layers preferably comprise polymeric materials. Any of the non-biodegradable and biodegradable polymers described hereinabove in relation to the matrix polymer may also form a barrier layer. Preferred barrier layer polymers include, but are not limited to, ethylenic copolymers such as ethylene vinyl acetate and copolymers of ethylene with acrylic or methacrylic acid, elastomers including elastomeric polyurethanes and block and random copolymers thereof, metallocene catalyzed polyethylene (mPE) and mPE copolymers, ionomers, silicones and mixtures thereof. Metallocene catalyzed polyethylenes and mPE copolymers, such as copolymers of ethylene with octene, and ionomers and may be particularly preferred polymeric barrier layer materials to control partitioning of any bioactive agent such as salicylic acid or sodium salicylate to the surface of the matrix polymer during processing and to provide controlled release of active agents from the matrix polymer.

[0059] A barrier layer and any contacting matrix polymer layer or region will preferably comprise different polymeric materials. Different polymeric materials will generally provide different rates of diffusion or release of bioactive agent. Thus, less permeable barrier layers may be provided to control the rate of release of a bioactive agent from a contacting matrix polymer region which may be more permeable to diffusion of a bioactive agent. For example, where an EVA copolymer having a vinyl acetate content of from about 19% to about 28% is used as the matrix polymer, an EVA copolymer having a lower vinyl acetate content of from about 3% to about 15% may be useful to form the contacting barrier layer. Lower vinyl acetate content EVA copolymers are useful as barrier layers because of their lower permeability, hence ability to release bioactive agent more slowly than higher vinyl acetate content copolymers. The relative rigidity or stiffness of such lower vinyl acetate content barrier layers may be offset

somewhat by the use of higher vinyl acetate content matrix polymer layers or regions.

[0060] While two barrier layers are provided in medical device **100** depicted in Fig. 1, it is understood that a medical device of the present invention may comprise an annular matrix polymer region provided with no barrier layer, or with a single barrier layer at least partially covering an exterior or interior surface of the annular matrix polymer region. It is also understood that while annular matrix polymer regions and annular barrier layers may be preferred in some embodiments of the present invention, neither any matrix polymer region nor any barrier layer need be annular.

[0061] In the medical device depicted in Fig. 1, and the above-described and other modifications thereof in accordance with the present invention, the first matrix polymer region preferably comprises a biocompatible matrix polymer as described herein, an antimicrobial agent, a microbial attachment biofilm synthesis inhibitor and, as optional components, one or more of a radio-opacifying agent and a therapeutic agent.

[0062] Another embodiment of the present invention comprising a multi-layer structure will now be described. In this embodiment, the device is designed to provide slower release of a bioactive and/or therapeutic agent from a first matrix polymer composition relative to release of a bioactive and/or therapeutic agent from a second matrix polymer composition. In this embodiment, there is provided an annular layer of the first matrix polymer composition between distinct annular layers of the second matrix polymer composition. In such a multilayer configuration, each surface of the second matrix polymer composition that would otherwise be exposed to the external environment is provided with a barrier layer. Similarly, barrier layers are provided between the annular layer of the first matrix polymer composition and the annular layers of the second matrix polymer composition. The resulting structure comprises seven layers, three of

which form distinct matrix polymer regions and four of which form barrier layers covering at least a portion of one or more surfaces of the matrix polymer regions. In this configuration, the bioactive and/or therapeutic agent from the annular layer comprising the first matrix polymer composition would have to diffuse through its own barrier layer, into and through an annular layer comprising the second matrix polymer composition and through another barrier layer before reaching the external environment. This multi-layer configuration provides a slower release of bioactive and/or therapeutic agent from the annular layer of the first matrix polymer composition relative to the rate of release of bioactive and/or therapeutic agent from the annular layer of the second matrix polymer composition.

[0063] A simplified schematic representation of this embodiment of the present invention is depicted in Fig. 2. Implantable or insertable medical device **200** in accordance with this embodiment of the present invention comprises annular first matrix polymer region **201**; annular first polymeric barrier layer **211** at least partially covering an interior surface of first matrix polymer region **201**; annular second polymeric barrier layer **212** at least partially covering an exterior surface of first matrix polymer region **201**; annular second matrix polymer region **202** at least partially covering an exterior surface of annular second polymeric barrier layer **212**; annular third polymeric barrier layer **213** at least partially covering an exterior surface of annular second matrix polymer region **202**; annular third matrix polymer region **203** disposed on an interior surface of annular first polymeric barrier layer **211**; and annular fourth polymer barrier layer **214** at least partially covering an interior surface of annular third matrix polymer region **203**.

[0064] Annular first, second, and third matrix polymer regions **201**, **202** and **203**,

respectively, may have the same or different compositions. In a preferred embodiment, annular second and third matrix polymer regions **202** and **203**, respectively, have the same composition which is different from the composition of annular first matrix polymer region **201**. In this preferred embodiment, it is also preferred that annular first and second polymeric barrier layers **211** and **212**, respectively, have the same composition and annular third and fourth polymer barrier layers **213** and **214**, respectively, have the same composition. In this embodiment, it is particularly preferred that the annular first and second polymeric barrier layers **211** and **212**, respectively, have a composition different from that of the annular third and fourth polymeric barrier layers, **213** and **214**, respectively. However, more broadly, annular first, second, third and fourth polymeric barrier layers **211**, **212**, **213** and **214**, respectively, may have the same or different compositions. Similarly, annular first, second and third matrix polymer regions **201**, **202** and **203**, respectively may have the same or different compositions.

[0065] Another embodiment of the present invention may also be described with reference to Fig. 2. In this embodiment, the medical device has two matrix polymer regions and three polymeric barrier layers. This embodiment of the present invention may be envisioned by removing, from the medical device depicted in Fig. 2, annular third matrix polymer region **203** and annular fourth polymer barrier layer **214**, thereby resulting in a five layer structure comprising two distinct matrix polymer regions (**201**, **202**) and three polymeric barrier layers (**211**, **212**, **213**) at least partially covering one or more surfaces of the distinct matrix polymer regions.

[0066] It is understood that other configurations of barrier layers and matrix polymer regions are within the scope of the present invention. For example, again with reference to Fig. 2, a five layer structure within the scope of the present invention may be

envisioned by removing annular third and fourth polymeric barrier layers, 213 and 214, respectively. In this embodiment, the resulting five layer structure will comprise three distinct matrix polymer regions (201, 202, 203) separated from each other by two barrier layers (211, 212) disposed on inner and outer surfaces of annular first matrix polymer region 201.

[0067] In the medical device depicted in Fig. 2, and the above-described and other modifications thereof in accordance with the present invention, any of the first, second and optional third matrix polymer regions preferably comprises a biocompatible matrix polymer as described herein and either or both of an antimicrobial agent and a microbial attachment biofilm synthesis inhibitor and, as optional components, one or more of a radio-opacifying agent and a therapeutic agent.

[0068] The present invention is not to be construed as limited in any way by the simplified schematic representations of the embodiments of the present invention as depicted in Figs. 1 or 2. Thus, a medical device in accordance with the present invention can be a single layer or multilayer construction; may have one or multiple matrix polymer regions and may have none, one or multiple barrier layers. Moreover, neither any matrix polymer region nor any barrier layer need be annular as depicted in the Figures. Further, where a barrier or other layer is provided in addition to a matrix polymer layer, any of a bioactive agent, a radio-opacifying agent and a therapeutic agent may be provided in or on such barrier or other layer.

[0069] Further optimization of release profiles can be obtained by providing a multilayer structure having both biodegradable and substantially non-biodegradable layers. Matrix polymer layers having different rates of biodegradation can, for example, provide different release profiles of bioactive and/or therapeutic agents. By appropriate

selection and placement of such biodegradable layers, release profiles can be optimized based on the desired time-dependent requirements for release of such bioactive and/or therapeutic agents.

[0070] Multiple layers may also be provided to act as barrier layers to separate, at least temporarily, otherwise incompatible polymers, bioactive agents, therapeutic agents and radio-opacifying agents. For example, such materials or agents may not be compatible with another such material or agent under the processing conditions employed to manufacture the medical device. As a specific example, an antimicrobial agent such as chlorhexidine may react with a microbial attachment/biofilm synthesis inhibitor such as salicylic acid when mixed with an EVA copolymer under certain conditions in a twin screw extruder. The resultant chemical modification of the compounds may render them ineffective for their intended purpose. As another example, a radio-opacifying agent such as bismuth subcarbonate may react with an antimicrobial agent such as salicylic acid under certain processing conditions necessary for a particular matrix polymer.

[0071] The use of a barrier layer is also advantageous in substantially reducing or preventing the preferential partitioning of a bioactive agent to the surface of a medical device during or subsequent to processing. For example, a microbial attachment/biofilm synthesis inhibitor such as salicylic acid may preferentially partition to the surface of a matrix polymer such as an EVA copolymer during or subsequent to some of the processing steps involved in formation of the medical device. This preferential partitioning may be referred to as "blooming." It is believed that blooming may result, at least in part, when the bioactive agent has limited solubility in the polymer, particularly as it is cooled after processing. Also, a bioactive agent that has greater solubility in water than in a matrix polymer may be more susceptible to blooming during processing of the

matrix polymer and bioactive agent. It may, therefore, be desirable to control moisture content during processing of the bioactive agent and matrix polymer to prevent blooming of bioactive agent. In any event, blooming may result in the appearance of crystals of the bioactive agent, such as salicylic acid, on the surface of the device within hours after processing.

[0072] In one embodiment of the present invention adapted to substantially reduce or prevent blooming, there is provided a multilayer structure comprising a first annular layer comprising a biocompatible matrix polymer, an antimicrobial agent, a microbial attachment/biofilm synthesis inhibitor; and annular first and second barrier layers on the exterior and interior surfaces, respectively, of the first annular layer (as optional components, a radio-opacifying agent and/or a therapeutic agent may also be added to one or more of the layers). Blooming or partitioning of a bioactive agent to a surface of the device can be effectively controlled by providing the first and second annular barrier layers in this embodiment. A medical device in accordance with this embodiment comprising a three layer structure adapted to substantially reduce blooming may have a structure similar to that shown in Fig. 1, described hereinabove.

[0073] In another aspect, the present invention is directed to a method of manufacturing an implantable or insertable medical device comprising (a) providing one or more biocompatible matrix polymers, one or more antimicrobial agents and one or more microbial attachment/biofilm synthesis inhibitor and, optionally, one or more of a radio-opacifying agent and/or a therapeutic agent; (b) processing the one or more biocompatible matrix polymers and the bioactive agents, preferably under conditions that substantially prevent preferential partitioning of any of the bioactive agents to a surface of

any of the biocompatible matrix polymers and that substantially prevent chemical modification of the bioactive agents.

[0074] Processing typically comprises mixing or compounding the matrix polymer, bioactive agents and optional radio-opacifying and/or therapeutic agents to form a homogeneous mixture thereof and shaping the homogenous mixture into a matrix polymer region of an implantable or insertable medical device. The mixing and shaping operations, as described more fully below, may be performed using any of the conventional devices known in the art for such purposes. In the following description, the one or more bioactive agents and optional radio-opacifying and/or therapeutic agents will, at times, be collectively referred to as "additives" or "agents."

[0075] During processing, there exists the potential for one or more of the polymer matrix material, bioactive agents and optional radio-opacifying and/or therapeutic agents to become chemically modified by cross-reacting with one another. These undesirable cross-reactions may result from the incompatibility or instability of these agents at the elevated temperatures typically involved during the processing. It is also believed that excessive moisture content during processing may facilitate chemical modification of the agents.

[0076] Excessive moisture content can also facilitate blooming of a bioactive agent to a surface of a matrix polymer. Other processing conditions can also result, as discussed hereinabove, in blooming of one or more of the bioactive agents to the surface of a matrix polymer during and/or subsequent to processing.

[0077] Hence, processing is preferably performed under conditions that substantially prevent preferential partitioning of any of the agents and substantially prevent chemical modification of the agents. It is understood that some partitioning and chemical

modification may be unavoidable during processing. Therefore, by “substantially prevent” is meant that no more than about 25% by weight, preferably less than about 10% by weight (based on the weight of the matrix polymer composition), of any bioactive agent is preferentially partitioned to a surface of a matrix polymer and/or chemically modified during processing.

[0078] Among the processing conditions that may be controlled during processing to substantially reduce the risk of partitioning and/or chemical modification are the temperature, moisture content, applied shear rate and residence time of the mixture of matrix polymer, bioactive agents, and optional radio-opacifying and/or therapeutic agents in a processing device.

[0079] Mixing or compounding a matrix polymer with one or more of the bioactive agents and optional radio-opacifying and/or therapeutic agents to form a homogeneous mixture thereof may be performed with any device known in the art and conventionally used for mixing polymeric materials with additives. Where thermoplastic materials are employed, a polymer melt is formed by heating the various agents, which can then be mixed to form a homogenous mixture. A common way of doing so is to apply mechanical shear to a mixture of the matrix polymer and additives. Devices in which the matrix polymer and additives may be mixed in this fashion include, but are not limited to, devices such as a single screw extruder, a twin screw extruder, a banbury mixer, a high-speed mixer, and a ross kettle.

[0080] Mixing may also be achieved by dissolving the matrix polymer with one or more of the bioactive agents and optional radio-opacifying and/or therapeutic agents in a solvent system or forming a liquid dispersion of the same.

[0081] Any of the matrix polymer and/or additives may be precompounded or

individually premixed to facilitate subsequent processing. For example, a radio-opacifying agent may be precompounded with a matrix polymer and then mixed with any bioactive agent. Alternatively, the radio-opacifying agent such as bismuth subcarbonate may be preblended with any bioactive agent in a device such as a v-mixer with an intensifier bar before being mixed with the matrix polymer.

[0082] In some preferred embodiments, a homogenous mixture of the matrix polymer and additives is produced using a twin screw extruder, such as a twin screw extruder with a low-shear profile design. Barrel temperature, screw speed and throughput are typically controlled to prevent partitioning and chemical modification as discussed hereinabove.

[0083] The conditions necessary to achieve a homogenous mixture of the matrix polymer and additives during compounding will depend, to some extent, on the specific matrix polymer as well as the type of mixing device used. For example, different matrix polymers will typically soften into a melt to facilitate mixing at different temperatures. It is generally preferred to mix the matrix polymer and additives at a temperature from about 60 °C to about 140 °C, more preferably from about 70 °C to about 100 °C, most preferably from about 80 °C to about 90 °C. These temperature ranges have been found to result in formation of a homogenous mixture of the matrix polymer and additives, while substantially preventing partitioning and chemical modification. Some combinations of matrix polymer and additive can be processed at a lower temperature than might otherwise be expected to result in homogeneous mixing. For example, while

[0084] 70 °C may be a relatively low temperature for processing an EVA copolymer and an additive, an antimicrobial agent such as triclosan, which melts at a temperature of around 50 °C, may act as a plasticizer for the EVA, facilitating use of a lower temperature

of about 70 °C. The ability to process the EVA at a lower temperature by virtue of an additive acting as a plasticizer advantageously reduces the risk of chemical modification of the additives if a higher temperature were otherwise required. Higher temperatures may be employed, however, during subsequent shaping of the homogenous mixture into a portion of a medical device as described herein. For example, higher temperatures may be necessary in localized portions of a coextrusion device used to apply a barrier layer onto one or more surfaces of the matrix polymer. However, the time at which the higher temperatures are encountered by the mixture are generally kept to a minimum.

[0085] The mixture of matrix polymer and additives can be shaped into at least a portion of a medical device in accordance with the present invention by means of any process conventionally used to shape polymeric materials such as thermoplastic and elastomeric materials. Among such shaping processes are included, but not limited to, extrusion including coextrusion, molding, calendaring, casting and solvent coating. Among preferred shaping processes are extrusion and coextrusion processes.

[0086] Coextrusion is a particularly preferred shaping process wherein at least a portion of a medical device in accordance with the present invention is a multilayer structure, for example, comprising one or more distinct matrix polymer regions and one or more barrier layers at least partially covering a surface of a matrix polymer region. Among preferred coextruded multilayer structures are those having 3 to 7 distinct layers as described hereinabove. Especially preferred coextruded structures are those in which each of the matrix polymer regions and contacting barrier layers have annular shapes. For example, a three layer structure may be formed by coextruding annular polymeric barrier layers with an annular matrix polymer region such that the polymeric barrier layers at least partially cover interior and exterior surfaces of the matrix polymer region.

Two, five, and seven layer constructions as described herein may be similarly formed by coextrusion, as can any multilayer construction having from 2 to about 50 layers. It is also understood that a medical device of the present invention may be formed by extruding a single annular matrix polymer containing bioactive agents, an optional radio-opacifying agent and an optional therapeutic agent. Multi-layer structures can also be formed by other processing and shaping techniques such as laminar injection molding (LIM) technology.

[0087] The temperatures used for shaping the matrix polymer and any barrier layers will, of course, depend on the particular materials used and the shaping device employed. Shaping process conditions, as with the mixing or compounding process conditions, may also result in undesirable partitioning and/or cross-reactions. Therefore, control of any shaping process condition such as temperature, moisture content, shear rate and residence time may be desirable to avoid partitioning and/or cross-reactions.

[0088] For example, a three layer structure comprising an annular matrix polymer region and two barrier layers covering an interior and exterior surface, respectively, of the matrix polymer region may be formed by coextruding the matrix polymer containing the bioactive agents and optional radio-opacifying agent and/or therapeutic agent. In such a coextrusion process, the barrel and shaping die temperatures, screw speed and compression ratio, may be controlled to prevent undesirable partitioning and chemical modification of the bioactive agents. For example, coextrusion of a 19% vinyl acetate EVA copolymer as a matrix polymer, compounded with 10% by weight triclosan, 10% by weight salicylic acid and 30% by weight bismuth subcarbonate may be coextruded with two layers of a metallocene catalyzed polyethylene ("mPE") copolymer such as an ethylene-octene copolymer (24% octene co-monomer) serving as barrier layers. In such a

coextrusion process, a screw speed of 35 rpm on a 3:1 compression ratio, using a 1" screw diameter with no mixing section and a barrel temperature of about 110 °C was found to be sufficient to substantially prevent cross-reactions and bioactive agent partitioning. As alluded to above, barrier layer materials may require higher processing temperatures during shaping than temperatures employed during compounding of the matrix polymer and additives. Consequently, it may be necessary to maintain portions of the extrusion apparatus at higher temperatures than employed during compounding. In this embodiment, a barrel temperature of about 110 °C and a shaping head temperature of about 150 °C are employed to facilitate formation of the mPE copolymer barrier layers. While these temperatures are higher than the temperature (about 70 °C) used to compound the EVA matrix polymer and additives, substantial partitioning and chemical modification of the bioactive agents may, nonetheless, be avoided, due in part to the short residence time at these temperatures.

[0089] Other shaping processes, as mentioned above, include extrusion coating and solvent coating. For example, a barrier layer polymer could be extruded onto a preformed matrix polymer region. This process is distinguished from a coextrusion process in which the matrix polymer and barrier layers are shaped substantially simultaneously. Alternatively, a barrier layer could be applied to a surface of a matrix polymer by applying a solvent solution or liquid dispersion of a barrier polymer onto a surface of the matrix polymer followed by removing the solvent or liquid dispersing agent, e.g., by evaporation. Such a solution or dispersion of the barrier polymer may be applied by contacting a surface of the matrix polymer with the solution or dispersion by, for example, dipping or spraying. The use of these other shaping processes are not limited to

the application of a barrier layer to a matrix polymer region. Therefore, a matrix polymer region may also be formed onto a preformed substrate by similar methods.

[0090] The medical device of the present invention may be any implantable or insertable medical device, particularly one that may be susceptible to microbial growth on and around the surfaces of the device, including attachment of microbes onto and the synthesis by attached microbes of biofilm on the surface of the medical device. Preferred implantable medical devices include those adapted to remain implanted for a relatively long-term, i.e., for period of from about 30 days to about 12 months or greater. However, devices intended to remain implanted for about 30 days or less are also included within the scope of the present invention.

[0091] Examples of implantable medical devices include, but are not limited to, stents, stent grafts, stent covers, catheters, artificial heart valves and heart valve scaffolds, venous access devices, vena cava filters, peritoneal access devices, and enteral feeding devices used in percutaneous endoscopic gastronomy, prosthetic joints and artificial ligaments and tendons. Preferred medical devices include those adapted to bridge or provide drainage between two sterile areas of the body or between a sterile and non-sterile area of the body. Devices adapted to bridge or provide drainage between a sterile and a non-sterile area of the body are particularly susceptible to microbial growth, attachment and biofilm formation due to contamination of the sterile area from microbes normally present in the non-sterile area. Medical devices intended to be implanted in or bridge sterile body environments may be susceptible to microbial growth, attachment and biofilm formation, for example, from microbial organisms that are ordinarily present in the non-sterile area (i.e., non-pathogenic organisms), from those that are present due to

disease, (i.e., pathogenic organisms) and from those introduced during the insertion or implantation of the medical device.

[0092] Stents include biliary, urethral, ureteral, tracheal, coronary, gastrointestinal and esophageal stents. Preferred stents include biliary stents, ureteral stents and pancreatic stents. The stents may be of any shape or configuration. The stents may comprise a hollow tubular structure which is particularly useful in providing flow or drainage through biliary and ureteral lumens. Stents may also be coiled or patterned as a braided or woven open network of fibers or filaments or, for example, as an interconnecting open network of articulable segments. Such stent designs may be more particularly suitable for maintaining the patency of a body lumen such as a coronary artery. Thus, stents adapted primarily to provide drainage, in contrast to stents adapted primarily to support a body lumen, will preferably have a continuous wall structure in contrast to an open network wall structure.

[0093] Stent covers are also a preferred medical device of the present invention. For example, a stent cover may comprise a thin wall tubular or sheath-like structure adapted to be placed over a stent comprising an open mesh stent of knitted, woven or braided design. A preferred stent cover is adapted to be placed over a biliary stent. The biliary stent can be made of any material useful for such purpose including metallic and non-metallic materials as well as shape memory materials. Among useful metallic materials include, but are not limited to, shape memory alloys such as Nitinol®, and other metallic materials including, but not limited to, stainless steel, tantalum, nickel-chrome, or cobalt-chromium, i.e., Elgiloy®. The biliary stent can be made from a single strand or multiple strands of any such material and may be self-expanding. The stent cover may comprise a matrix polymer as described herein which comprises an antimicrobial agent such as

triclosan, a microbial attachment/biofilm synthesis inhibitor such as salicylic acid and a radio-opacifying agent such as bismuth subcarbonate. A particularly preferred stent cover comprises an elastomeric polyurethane or polyurethane copolymer as described above. The stent cover is particularly advantageous in reducing tissue growth through an open mesh stent while at the same time reducing microbial growth on and around the surface of the stent, reducing attachment of microbes onto the stent, and reducing the synthesis of biofilm on the surface of the stent.

[0094] Another preferred medical device of the present invention is a pancreatic stent that provides drainage from the pancreas to the duodenum. Normally, the pancreas drains into the duodenum by the pancreatic duct. Implantable pancreatic drainage devices are sometimes desired to alleviate problems such as strictures, sphincter stenoses, obstructing stones or to seal duct disruptions. However, when the pancreatic duct is opened, or an implantable medical device is placed in the pancreas, morphological changes may occur that may lead to pancreatitis.

[0095] It is believed that morphological changes in the pancreas upon insertion of an implantable medical device may be related to the pH difference between a normal pancreas and the duodenum into which the pancreas drains. The pancreas has a higher pH than the duodenum and excretes aqueous bicarbonate to buffer the duodenum. The implantation of a medical device into the pancreas may substantially reduce the ability or effectiveness of the pancreas to provide this buffering action, potentially leading to undesirable morphological changes in the pancreas.

[0096] It is believed that by providing a pancreatic stent that releases a buffering agent so as to create a pancreatic pH level in the environment of the implanted medical device, undesirable morphological changes in the pancreas may be substantially reduced

or even prevented. This may be accomplished by providing an agent in or on the surfaces of a pancreatic stent such that when the pancreatic stent is exposed to physiological fluids, the buffering agent is released from the stent creating a locally higher pH environment around the device. Among buffering agents are included, but not limited to, bicarbonate salts such as sodium or potassium bicarbonate. Such buffering agents may be incorporated, for example, in a matrix polymer in a manner described hereinabove with respect to bioactive agents, or they may be applied as a coating on a surface of a matrix polymer, or they may be applied in or as a coating on any optional barrier layer by any of the methods described above.

[0097] The invention will be further described with reference to the following non-limiting Examples. It will be apparent to those skilled in the art that many changes can be made in the embodiments described in such Examples, consistent with the foregoing description, without departing from the scope of the present invention.

EXAMPLE 1

[0098] A single-layer matrix polymer structure is formed from a mixture containing an ethylene vinyl acetate (EVA) copolymer having a 19% vinyl acetate content, 10% triclosan by weight of the mixture as an antimicrobial agent, 10% salicylic acid by weight of the mixture as a microbial attachment/biofilm synthesis inhibitor, and 30% bismuth subcarbonate by weight of the mixture as a radio-opacifying agent. The bismuth subcarbonate is precompounded with the EVA copolymer (62.5% EVA/37.5% bismuth subcarbonate) and added to the triclosan and salicylic acid bioactive agents.

Alternatively, the bismuth subcarbonate is preblended with the triclosan and salicylic acid in a v-mixer with intensifier bar before adding to the polymer. A v-blender with an

approximately 13 rpm shell speed and a pin-type intensifier bar at about 120 rpm for about 15 minutes produces a consistent, homogenous powder blend. The triclosan, salicylic acid and bismuth subcarbonate are compounded with the EVA copolymer in an 18 mm screw diameter twin screw extruder with a low-shear profile screw design. The barrel temperature in the screw is about 70 °C with a screw speed of about 200 rpm and a throughput of about 3.5 kg/hr. Since 70 °C is a relatively low processing temperature for EVA, the triclosan acts as a plasticizer to facilitate compounding and subsequent extrusion. After compounding, the mixture is extruded into tubes in a standard 1" screw diameter extruder with a 24:1 L/D, 3:1 compression ratio, low shear screw. Maximum barrel temperature is about 100 °C to prevent reaction between the bismuth subcarbonate and the salicylic acid. The screw speed is kept relatively low, around 20 rpm, to keep the shear rate low and prevent excess viscous heat dissipation.

EXAMPLE 2

[0099] A three-layer structure is formed having a matrix polymer region with the same composition and compounding as described in Example 1, and coextruded with barrier layers covering the inner and outer surfaces of the matrix polymer region. The barrier layers are formed of an ethylene-octene copolymer in which the octane comonomer content is about 24%. Each of the barrier layers forms about 5% of the total wall thickness of the three-layer structure. Thicker or thinner barrier layers may be provided to retard or increase the release rate of the bioactive agents from the matrix polymer. The compounded matrix polymer and barrier layers are coextruded while controlling the screw speed and temperature to avoid overheating and undesirable cross-reactions and the consequent chemical modification of the bioactive agents and/or radio-

opacifying agent. The coextrusion is performed using a screw speed of about 35 rpm on a 3:1 compression ratio, a 1" diameter screw with no mixing section. A barrel temperature of about 110 °C was found to substantially prevent cross-reactions. The copolymer barrier layers require higher processing temperatures at the shaping die at the head of the extruder. A shaping die temperature of about 150 °C was found to provide adequate head pressure, layer quality and cross-reaction at the shaping die.

EXAMPLE 3

[0100] Approximately 2 cm lengths of extruded 19% vinyl acetate EVA copolymer tubing containing varying amounts of triclosan (TCN), salicylic acid (SA) and bismuth subcarbonate (BsC) are incubated in phosphate buffered saline (PBS) at 37 °C for 0 ("no treatment"), 3, 8 and 28 days. The purpose of incubation in PBS is to show longevity of SA inhibition on bacterial attachment after exposure, and release of SA from the extruded tube. After incubation in PBS, the tubes are exposed a solution containing approximately 10^{-4} to 10^{-5} cfu/ml *e. coli* for about 4 hr at 37 °C with rotation at about 100 rpm. Subsequent to this exposure, the samples are rinsed in saline and "rolled" following an established pattern onto a standard Mueller-Hinton agar plate. The plates are incubated for about 18 to 24 hr to allow colonies to form. The colonies are counted and expressed as cfu per inch of tube.

[0101] Figure 3 shows the normalized inhibitory response of the tubes. The amounts of TCN, SA and BsC in the tubes are represented as %TCN/%SA/%BsC (wt% based on weight of vinyl acetate EVA copolymer). Therefore, a tube having 10% TCN, 0% SA and 30% BsC is designated in Fig. 3 as "10/0/30". Fig. 3 shows the inhibitory response of five tubes having varying weight percentages of TCN and SA and 30% BsC,

normalized to a 10/0/30 tube, given an inhibitory response value of 1. Fig. 3 shows that tubes containing 10% TCN and varying amounts (1%, 3% and 10% SA) inhibited bacterial attachment more effectively than tubes containing only TCN ("10/0/30") and inhibited bacterial attachment more effectively than tubes containing neither TCN nor SA ("0/0/30"). Fig. 3 also shows that, as the amount of SA increased from 0% to 10%, with TCN constant at 10%, the tubes were generally more effective at inhibiting bacterial attachment, suggesting that SA provides a synergistic effect. Fig. 3 further shows that incubation of the tubes in PBS prior to exposure to *e. coli* did not significantly affect bacterial inhibition, suggesting that effective amounts of TCN and SA remained in the extruded tubes after extended incubation in PBS, i.e., that the bioactive agents were not excessively or prematurely leached out of the extruded tubes. Fig. 4 shows results (not normalized) for similar tubes incubated for 3 and 8 days in PBS prior to exposure to *e. coli*:

EXAMPLE 4

[0102] Approximately 2 cm lengths of extruded 19% vinyl acetate EVA copolymer tubing containing varying amounts of triclosan (TCN), salicylic acid (SA) and bismuth subcarbonate (BsC) are inserted into an agar lawn of either *e. coli* (Fig. 5) or staph (Fig. 6). The tubes are positioned so as to extend vertically upwardly from the surface of the agar lawn (similar to birthday candles). After 24 hours in the agar lawn, the zone (diameter) of bacterial growth inhibition around the tubes is measured. The tubes are repositioned in fresh agar plates every 24 hours, and the zone of bacterial growth inhibition is again measured. Fig. 5 shows the measurement results for the tubes positioned in the agar lawn of *e. coli* and Fig. 6 shows the results for the tubes positioned

in the agar lawn of staph. Figs. 5 and 6 show that the zone of bacterial growth inhibition was larger as the percentage of TCN increased from 0% to a maximum of 10%. A tube containing no TCN, but varying amounts of SA did not effectively inhibit bacterial growth, suggesting that bacterial growth inhibition (as opposed to inhibition of bacterial attachment) is predominantly provided by TCN. Figs. 5 and 6 also show that, for a given percentage of TCN, the measured zone of bacterial growth inhibition is similar over a period extending to about 40 days or longer, suggesting that the TCN component in the extruded tubes effectively maintains its activity for extended periods of time.

[0103] The invention may be embodied in other specific forms without departing from its proper scope. The described embodiments and Examples are to be considered in all respects only as illustrative and not restrictive. The scope of the invention is, therefore, indicated by the appended claims rather than by the foregoing description. All changes that come within the meaning and range of equivalency of the claims are to be embraced within their scope.

What is claimed is:

1. An implantable medical device comprising (a) at least one biocompatible matrix polymer region and (b) bioactive agents comprising an antimicrobial agent and a microbial attachment/biofilm synthesis inhibitor, wherein the device comprises a multilayer structure formed by coextrusion.
2. The medical device of claim 1, wherein both the antimicrobial agent and microbial attachment/biofilm synthesis inhibitor are present in a single distinct matrix polymer region.
3. The medical device of claim 1, wherein the antimicrobial agent and the microbial attachment/biofilm synthesis inhibitor are present in distinct matrix polymer regions.
4. The medical device of claim 1, wherein said antimicrobial agent is present in an amount effective to inhibit the growth of microbes on and around the device and the microbial attachment/biofilm synthesis inhibitor is present in an amount effective to inhibit the attachment of microbes onto and the synthesis and accumulation of biofilm from attached microbes on the surface of the device.
5. The medical device of claim 1, wherein said device is adapted to remain implanted for a period of greater than about 30 days.

6. The medical device of claim 1, wherein said matrix polymer comprises a biocompatible biodegradable polymer.
7. The medical device of claim 1, wherein said matrix polymer comprises a biocompatible non-biodegradable polymer.
8. The medical device of claim 7, wherein said non-biodegradable polymer is selected from the group consisting of ethylene vinyl acetate copolymers, copolymers of ethylene with acrylic acid or methacrylic acid, elastomeric polyurethanes and polyurethane copolymers, metallocene catalyzed polyethylene, ionomers and vinyl aromatic copolymers.
9. The medical device of claim 6, wherein said biodegradable polymer is selected from the group consisting of polylactic acid, polyglycolic acid, copolymers and mixtures thereof.
10. The medical device of claim 8, wherein said non-biodegradable polymer is an ethylene vinyl acetate copolymer.
11. The medical device of claim 10, wherein said ethylene vinyl acetate copolymer has a vinyl acetate content of from about 19% to about 28%.

12. The medical device of claim 10, wherein said ethylene vinyl acetate copolymer has a vinyl acetate content of from about 3% to about 15%.
13. The medical device of claim 1, wherein said antimicrobial agent is selected from the group consisting of triclosan and chlorhexidine and mixtures thereof.
14. The medical device of claim 13, wherein said antimicrobial agent is triclosan.
15. The medical device of claim 14, wherein said microbial attachment/biofilm synthesis inhibitor is selected from the group consisting of NSAIDs, EDTA and EGTA.
16. The medical device of claim 15, wherein said microbial attachment/biofilm synthesis inhibitor is salicylic acid or a salt or derivative thereof.
17. The medical device of claim 16, wherein said microbial attachment/biofilm synthesis inhibitor is salicylic acid.
18. The medical device of claim 4, wherein the amount of said antimicrobial agent present in said matrix polymer is from about 0.5% to about 25% by weight of the matrix polymer.
19. The medical device of claim 4, wherein the amount of said microbial attachment/biofilm synthesis inhibitor present in said matrix polymer is from about 0.5% to about 25% by weight of the matrix polymer.

20. The medical device of claim 1, wherein said matrix polymer further comprises a radio-opacifying agent.
21. The medical device of claim 20, wherein said radio-opacifying agent comprises bismuth subcarbonate.
22. The medical device of claim 20 wherein the amount of said radio-opacifying agent present in said matrix polymer is from about 0.5% to about 45% by weight of the matrix polymer.
23. The medical device of claim 1, wherein the matrix polymer further comprises at least one therapeutic agent.
24. The medical device of claim 23, wherein the therapeutic agent is selected from the group consisting of chemotherapeutic agents, NSAIDs, steroidal anti-inflammatory agents, and mixtures thereof.
25. The medical device of claim 23, wherein the therapeutic agent is selected from the group consisting of cisplatin, methotrexate, doxorubicin, paclitaxel, docetaxel, dexamethasone, hydrocortisone and prednisone.
26. The medical device of claim 1, further comprising one or more barrier layers at least partially covering said at least one matrix polymer region.

27. The medical device of claim 26, comprising a first matrix polymer region; a first polymeric barrier layer at least partially covering an interior surface of said first matrix polymer region; and a second polymeric barrier layer at least partially covering an exterior surface of said first matrix polymer region.

28. The medical device of claim 27, wherein each of said first matrix polymer region, and said first and second polymeric barrier layers is in the form of an annulus.

29. The medical device of claim 28, wherein the first and second polymeric barrier layers comprise the same polymeric materials.

30. The medical device of claim 28, wherein the first and second polymeric barrier layers comprise different polymeric materials.

31. The medical device of claim 27, further comprising a second and, optionally, a third matrix polymer region and a third and, optionally, a fourth polymeric barrier layer; wherein the second matrix polymer region is disposed on an outside surface of the second polymeric barrier layer and the third polymeric barrier layer at least partially covers an exterior surface of said second matrix polymer region; and, wherein the third matrix polymer region, when present, is disposed on an interior surface of said first polymeric barrier layer and the fourth polymeric barrier layer at least partially covers an interior surface of said third matrix polymer region.

32. The medical device of claim 27, wherein the first matrix polymer region comprises an ethylene vinyl acetate copolymer.
33. The medical device of claim 32, wherein each of the first and second polymeric barrier layers comprises a material selected from the group consisting of metallocene catalyzed polyethylenes and polyethylene copolymers, ionomers, elastomeric polyurethanes and polyurethane copolymers, ethylene vinyl acetate copolymers and copolymers of ethylene with acrylic acid or methacrylic acid.
34. The medical device of claim 33, wherein the antimicrobial agent is selected from the group consisting of triclosan, chlorhexidine and combinations thereof, and the microbial attachment/biofilm synthesis inhibitor is salicylic acid or a salt thereof.
35. The medical device of claim 1, wherein the medical device is selected from the group consisting of a stent cover, a biliary stent, a ureteral stent, a pancreatic stent, a urinary catheter, a venous access device, a peritoneal access device, a device connecting or providing drainage between two sterile body environments, and a device connecting or providing drainage between a non-sterile and a sterile body environment.
36. The medical device of claim 35, wherein the device comprises a device connecting or providing drainage between a non-sterile and a sterile body environment.
37. The medical device of claim 36, wherein the device comprises a hollow tubular structure.

38. The medical device of claim 35, wherein the device comprises a stent cover.
39. The medical device of claim 38, wherein said biocompatible polymeric matrix comprises polyurethane, said antimicrobial agent comprises triclosan, said microbial attachment/biofilm synthesis inhibitor comprises salicylic acid or a salicylic acid derivative and further comprising a bismuth subcarbonate radio-opacifying agent.
40. The medical device of claim 38, wherein the stent cover comprises a hollow tubular structure adapted to be placed over a stent that comprises a woven, knitted or braided open mesh design comprising a biocompatible material.
41. The medical device of claim 40, wherein the stent cover is placed over a biliary stent.
42. The medical device of claim 40, wherein the biocompatible material is selected from the group consisting of stainless steel or a shape memory material.
43. The medical device of claim 35, wherein the medical device comprises a pancreatic stent that provides drainage from the pancreas to the duodenum.
44. The medical device of claim 43, wherein the pancreatic stent comprises a buffering agent.

45. The medical device of claim 44, wherein said buffering agent, upon exposure to physiological fluids, creates a pancreas-compatible pH level in an environment in which the pancreatic stent is implanted.

46. The medical device of claim 45, wherein said buffering agent is a bicarbonate salt.

47. The medical device of claim 46, wherein said bicarbonate salt is selected from the group consisting of sodium and potassium bicarbonate.

48. A method of manufacturing an implantable or insertable medical device comprising: providing a combination of (a) one or more biocompatible matrix polymers and (b) bioactive agents comprising an antimicrobial agent and a microbial attachment/biofilm synthesis inhibitor; processing said combination under conditions that substantially prevent preferential partitioning of any of said bioactive agents to a surface of any of said biocompatible matrix polymers and that substantially prevent chemical modification of said bioactive agents by providing a multilayer structure that is formed by coextrusion.

49. The method of claim 48, further comprising controlling either or both of the temperature and moisture content during said processing.

50. The method of claim 48, wherein said processing comprises mixing said one or more biocompatible matrix polymers with one or more of said bioactive agents to a form a homogeneous mixture of said one or more matrix polymers and said one or more bioactive agents.

51. The method of claim 50, wherein said homogeneous mixture comprises both bioactive agents.

52. The method of claim 50, wherein said mixing comprises applying mechanical shear to said one or more biocompatible matrix polymers and said one or more bioactive agents with a device selected from the group consisting of a single screw extruder, a twin screw extruder, a banbury mixer, a high-speed mixer and a ross kettle.

53. The method of claim 50, where said mixing comprises forming a solvent solution or a liquid dispersion of said one or more bioactive agents and said one or more biocompatible matrix polymers.

54. The method of claim 50, further comprising shaping said homogenous mixture into a matrix polymer region of an implantable or insertable medical device.

55. The method of claim 54, wherein said shaping comprises a process selected from molding, calendaring, casting and solvent coating.

56. The method of claim 54, wherein said shaping comprises extrusion.
57. The method of claim 56, wherein said extrusion comprises forming at least one annular matrix polymer region.
58. The method of claim 57, further comprising forming at least one polymeric barrier layer at least partially covering a surface of said annular matrix polymer region.
59. The method of claim 58, wherein said method comprises a process selected from extrusion coating said polymeric barrier layer onto said annular matrix polymer region and solvent coating said polymeric barrier layer onto said annular matrix polymer region.
60. The method of claim 58, wherein said covering comprises coextruding said polymeric barrier layer and said annular matrix polymer region.
61. The method of claim 58, forming a first polymeric barrier layer at least partially covering an interior surface of said annular matrix polymer region and forming a second polymeric barrier layer at least partially covering an exterior surface of said annular matrix polymer region.
62. The method of claim 61, wherein said covering comprises coextruding said first and second polymer barrier layers with said annular matrix polymer region.

63. The method of claim 50, wherein said processing comprises forming homogeneous first and second mixtures of first and second biocompatible matrix polymers and one or more of said bioactive agents and, optionally, forming a homogenous third mixture of a third biocompatible matrix polymer and one or more of said bioactive agents.

64. The method of claim 63, comprising coextruding said homogenous first and second mixtures to form first and second annular matrix polymer regions and, optionally, coextruding therewith said homogeneous third mixture to form a third annular matrix polymer region.

65. The method of claim 64, further comprising forming at least first and second polymeric barrier layers at least partially covering interior and exterior surfaces of said first annular matrix polymer region; forming a third polymer barrier layer at least partially covering an exterior surface of said second annular matrix polymer region and, optionally, forming a fourth polymeric barrier layer at least partially covering an interior surface of third annular matrix polymer region.

66. The method of claim 65, wherein said covering comprises coextruding said first, second and third polymeric barrier layers with said first and second annular matrix polymer regions and, optionally, coextruding therewith said fourth polymeric barrier layer and said third annular matrix polymer region.

67. The method of claim 62, wherein said first annular matrix polymer region and said first and second barrier layers comprise a material selected from the group consisting of ethylene vinyl acetate copolymers, copolymers of ethylene with acrylic acid or methacrylic acid, elastomeric polyurethanes and polyurethane copolymers, metallocene catalyzed polyethylene and polyethylene copolymers, ionomers, vinyl aromatic copolymers, silicones and mixtures thereof.

68. The method of claim 67, wherein said first annular matrix polymer region comprises an ethylene vinyl acetate copolymer having a vinyl acetate content of from about 19% to about 28% and said first and second polymeric barrier layers comprise a metallocene catalyzed polyethylene or polyethylene copolymer, or an ionomer.

69. The method of claim 68, wherein said first annular matrix polymer region comprises salicylic acid or a salt thereof as said microbial attachment/biofilm synthesis inhibitor, triclosan as said antimicrobial agent and bismuth subcarbonate as a radio-opacifying agent.

70. The medical device of claim 26, wherein at least one of said one or more barrier layers comprises a biodegradable polymer.

71. The medical device of claim 70, where said biodegradable polymer is selected from the group consisting of polylactic acid, polyglycolic acid and copolymers and mixtures thereof.

72. An implantable or insertable medical device comprising at least one biocompatible matrix polymer region comprising a material selected from the group consisting of ethylene vinyl acetate copolymers, copolymers of ethylene with acrylic acid or methacrylic acid, metallocene catalyzed polyethylenes and polyethylene copolymers, ionomers, vinyl aromatic copolymers, elastomeric polyurethanes and polyurethane copolymers, silicones and mixtures thereof; bioactive agents comprising an antimicrobial agent selected from the group consisting of triclosan, chlorhexidine and mixtures thereof; a microbial attachment/biofilm synthesis inhibitor selected from the group consisting of salicylic acid and salts and derivatives thereof; and, a radio-opacifying agent selected from the group consisting of bismuth subcarbonate, bismuth oxychloride, bismuth trioxide, barium sulfate, tungsten and mixtures thereof,

wherein the device comprises a multilayer structure formed by coextrusion.

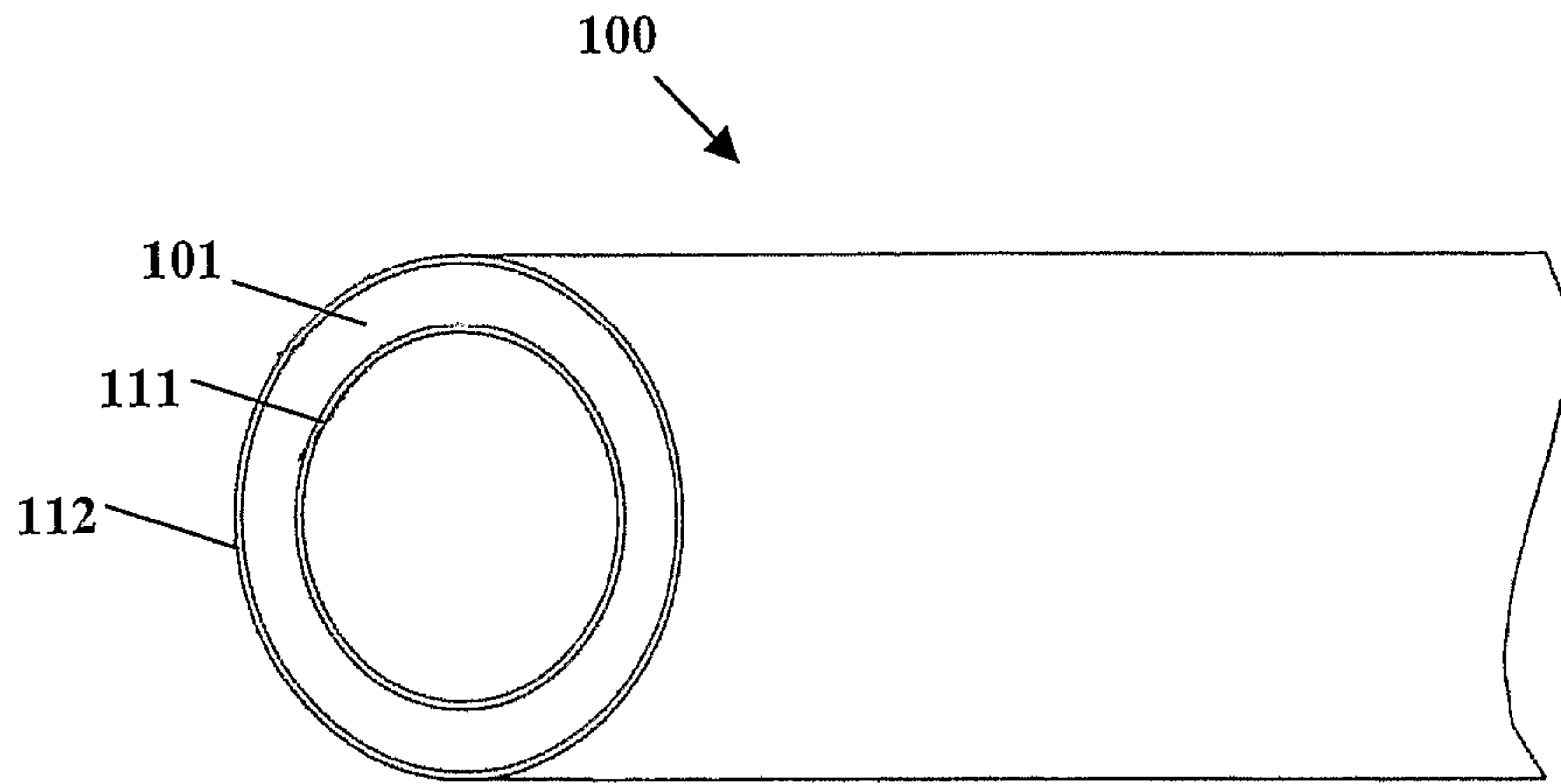

Fig. 1

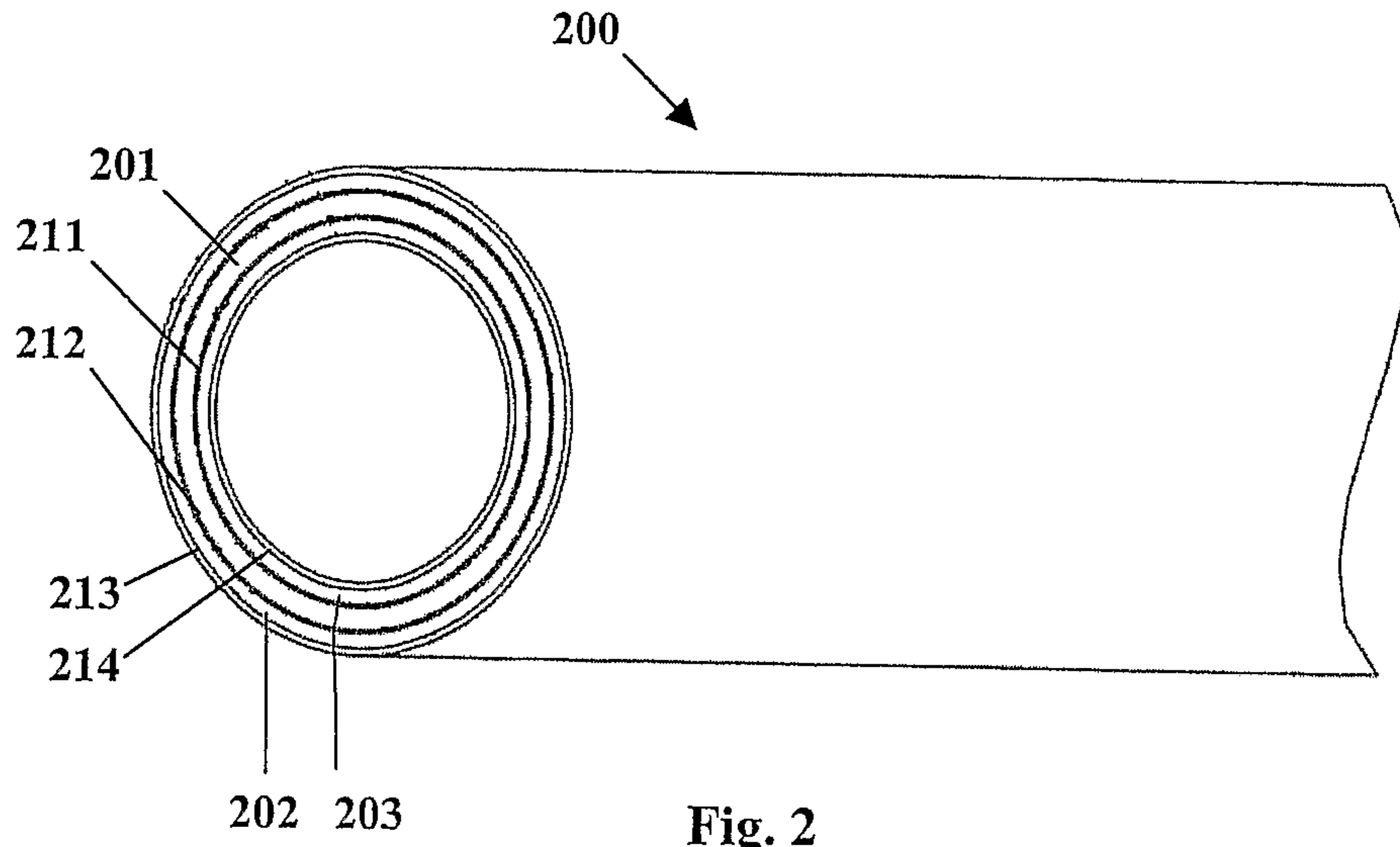

Fig. 2

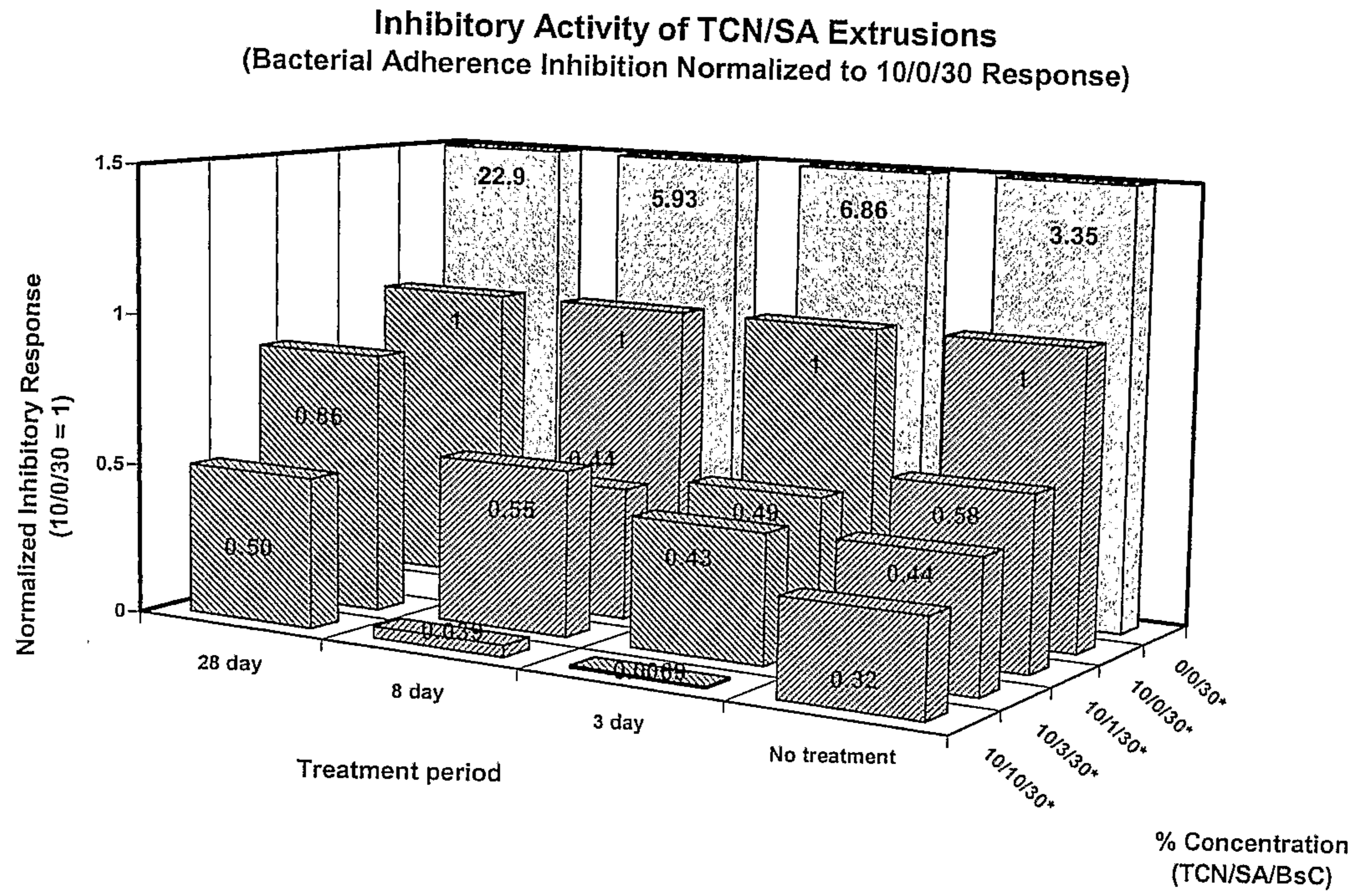

Fig. 3

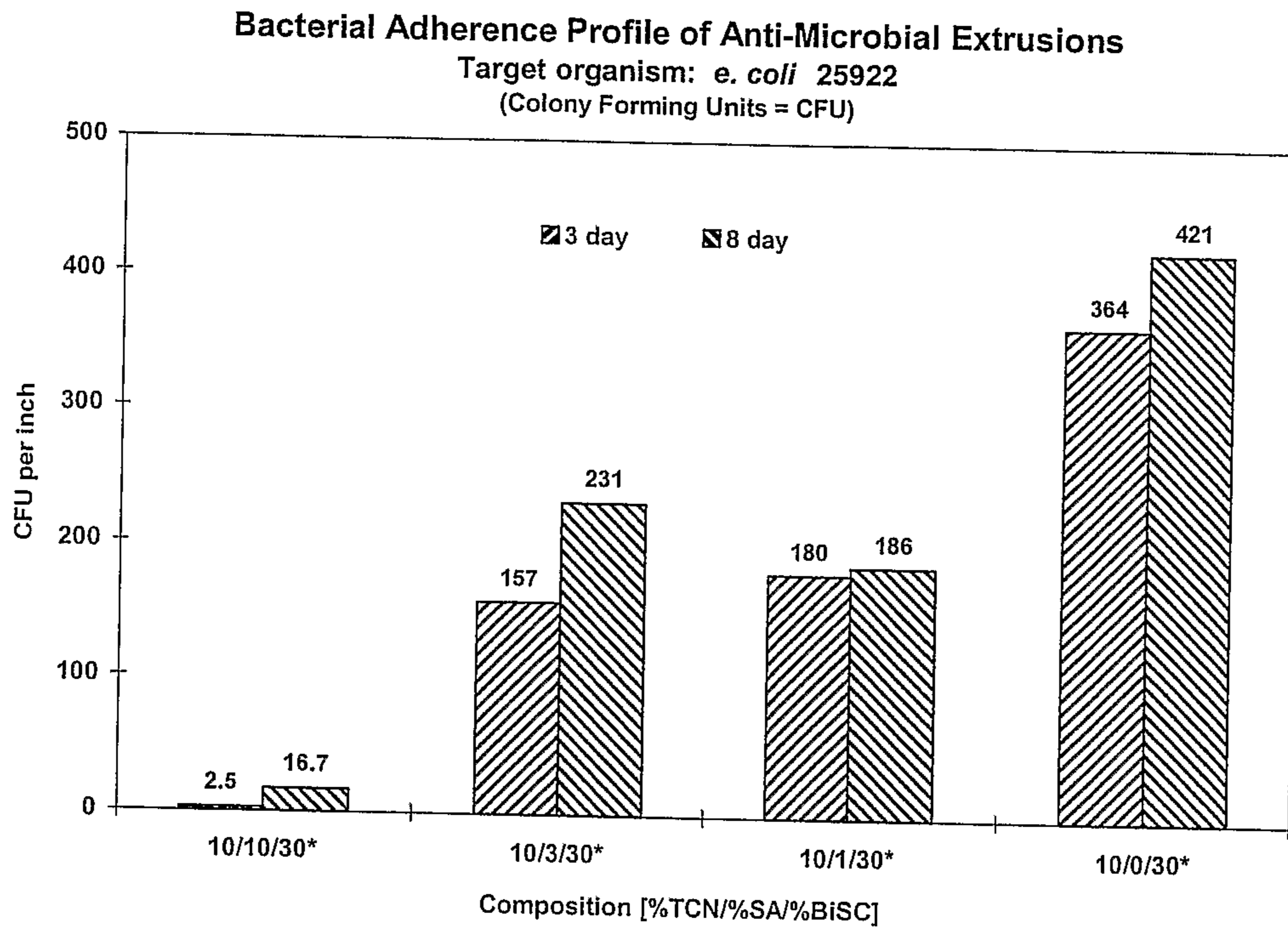

Fig. 4

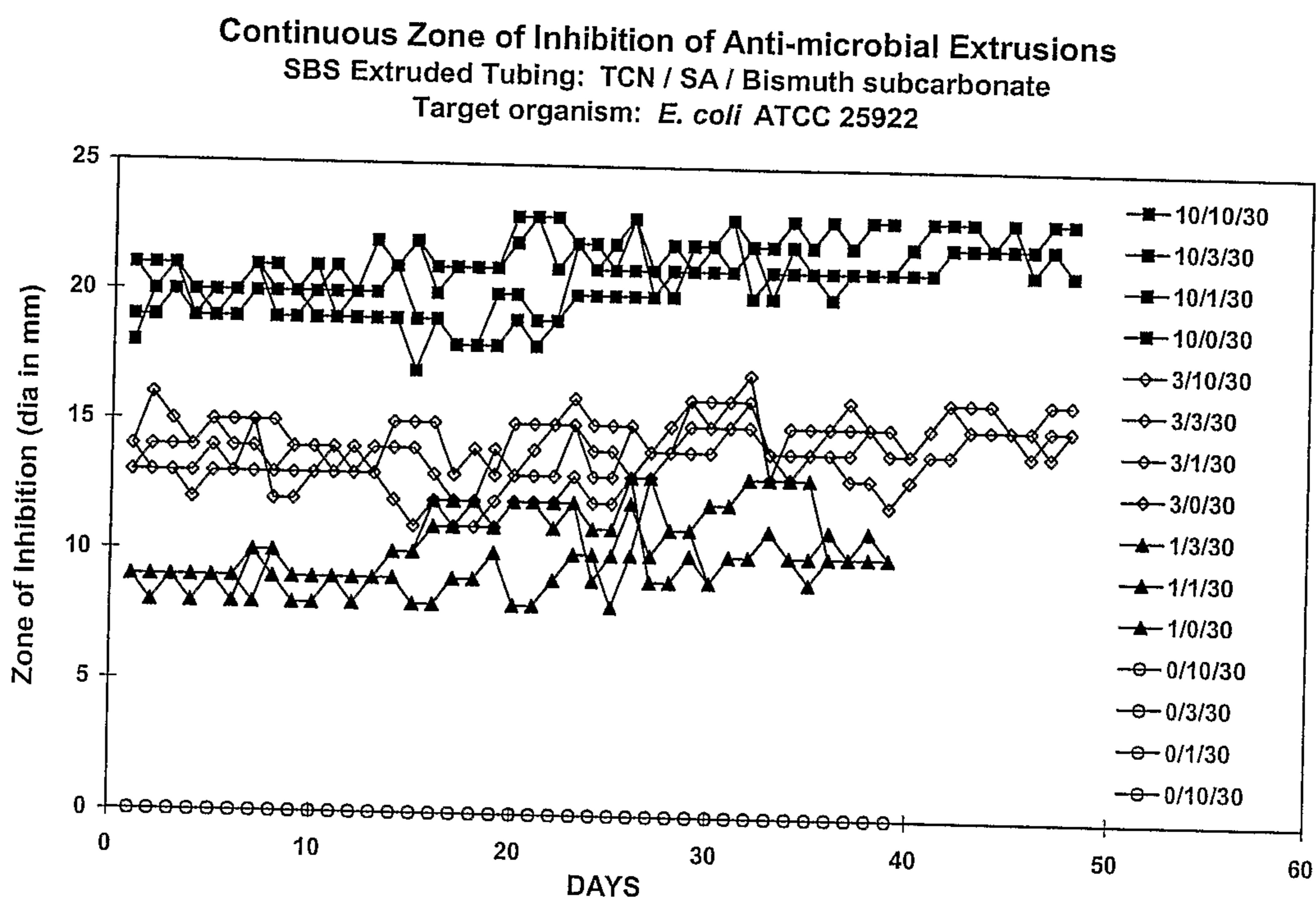

Fig. 5

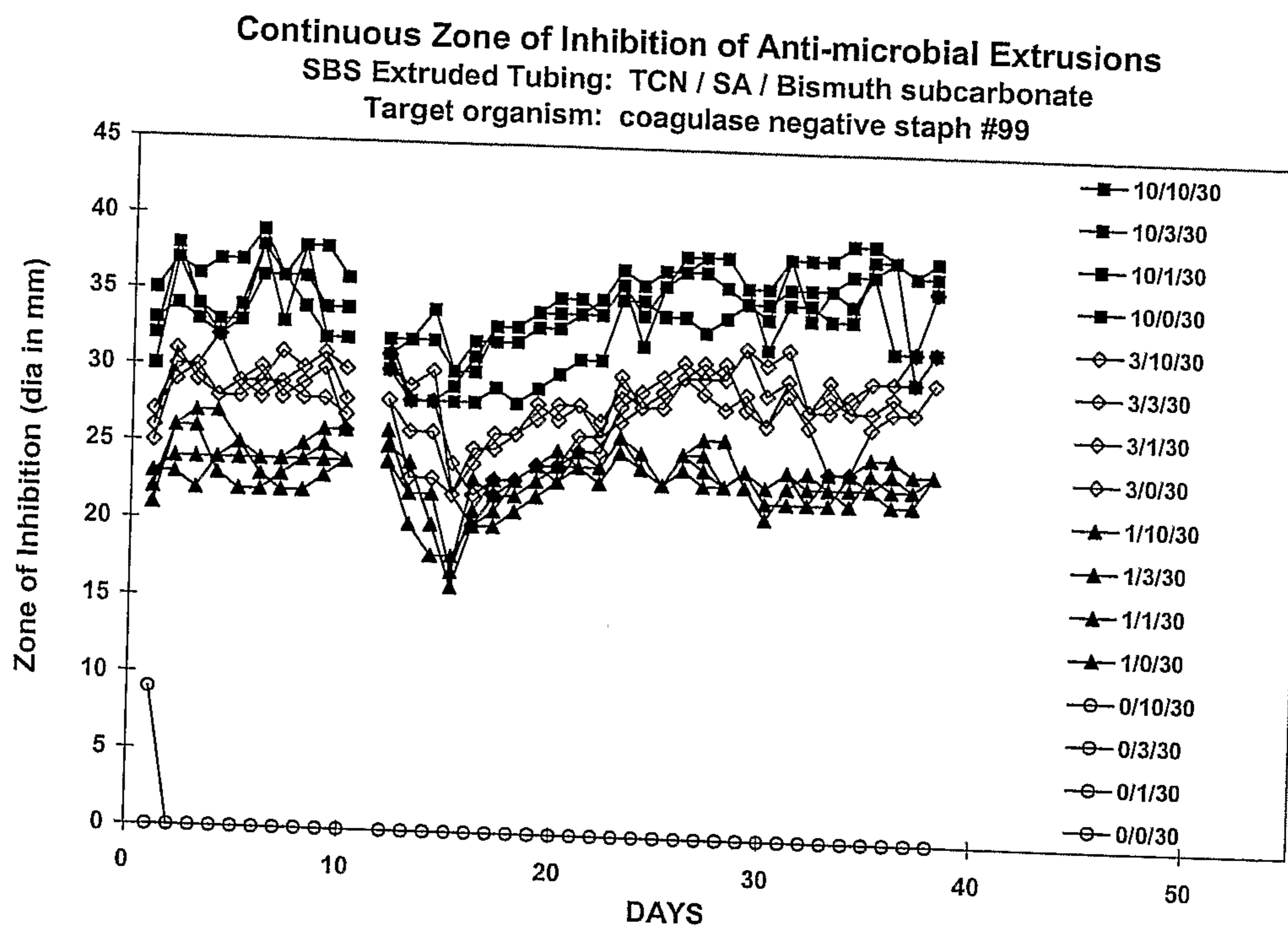

Fig. 6

100



101



111



112

