



- (51) **International Patent Classification:**
B26B 19/04 (2006.01) *B26B 19/38* (2006.01)
B26B 19/28 (2006.01)
- (21) **International Application Number:**
PCT/IB2011/053023
- (22) **International Filing Date:**
7 July 2011 (07.07.2011)
- (25) **Filing Language:** English
- (26) **Publication Language:** English
- (30) **Priority Data:**
10007144.8 10 July 2010 (10.07.2010) EP
- (71) **Applicant (for all designated States except US):** BRAUN GMBH [DE/DE]; Frankfurter Strasse 145, 61476 Kronberg-Taunus (DE).
- (72) **Inventors; and**
- (75) **Inventors/Applicants (for US only):** ERNDT, Andreas [DE/DE]; Marienburger Strasse 5, 65779 Kelkheim (DE).
KRAUSS, Joachim [DE/DE]; Gernsheimer Strasse 46,

643 14 Pfungstadt (DE). **KAPPES, Diana** [DE/DE]; Lorsbacher Strasse 51, 65817 Eppstein (DE). **SALOMEZ, Nicolas** [DE/DE]; Richard-Wagner-Strasse 22, 65760 Eschborn (DE). **DIETZEL, Daniel** [DE/DE]; Hornauer Strasse 43, 65779 Kelkheim (DE).

(74) **Common Representative:** BRAUN GMBH; c/o Eileen L. Hughett, The Procter & Gamble Company, Global Patent Services, 299 East Sixth Street Sycamore Building, 4th Floor, Cincinnati, Ohio 45202 (US).

(81) **Designated States (unless otherwise indicated, for every kind of national protection available):** AE, AG, AL, AM, AO, AT, AU, AZ, BA, BB, BG, BH, BR, BW, BY, BZ, CA, CH, CL, CN, CO, CR, CU, CZ, DE, DK, DM, DO, DZ, EC, EE, EG, ES, FI, GB, GD, GE, GH, GM, GT, HN, HR, HU, ID, IL, IN, IS, JP, KE, KG, KM, KN, KP, KR, KZ, LA, LC, LK, LR, LS, LT, LU, LY, MA, MD, ME, MG, MK, MN, MW, MX, MY, MZ, NA, NG, NI, NO, NZ, OM, PE, PG, PH, PL, PT, RO, RS, RU, SC, SD, SE, SG, SK, SL, SM, ST, SV, SY, TH, TJ, TM, TN, TR, TT, TZ, UA, UG, US, UZ, VC, VN, ZA, ZM, ZW.

[Continued on next page]

(54) **Title:** ELECTRICALLY OPERATED SHAVER WITH REPLACEABLE CUTTING DEVICE

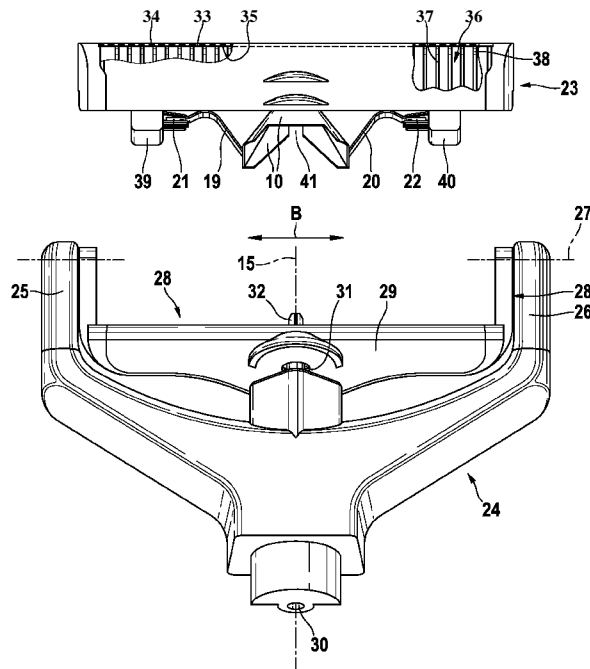

Fig. 1

(57) **Abstract:** The invention relates to an electrically operated shaver with at least one upper blade (33) attachable to a shear head frame (24) by means of a removable frame (23), on the underside of which (35) lies a linearly oscillating lower blade (36). The lower blade (36) is connected via a clutch engagement (48, 42) with an oscillating bridge (10) mounted on either side on the shaver by resilient arms (19, 20). The oscillating bridge (10) is also connected to the drive shaft (3) of an electric motor (2) via a gear mechanism (41, 6, 5, 4), so that when the motor (2) is running, the oscillating bridge (10), and thus also the lower blade (36), is set in linear reciprocating motion. According to the invention, the resilient arms (19, 20) of the oscillating bridge (10) are arranged on the removable frame (23). In this way, the oscillating bridge which often wears out very quickly, can also be replaced when the cutting device is replaced. This prevents malfunction and potentially high repair expenses, thus reducing costs.



(84) **Designated States** (unless otherwise indicated, for every kind of regional protection available): ARIPO (BW, GH, GM, KE, LR, LS, MW, MZ, NA, SD, SL, SZ, TZ, UG, ZM, ZW), Eurasian (AM, AZ, BY, KG, KZ, MD, RU, TJ, TM), European (AL, AT, BE, BG, CH, CY, CZ, DE, DK, EE, ES, FI, FR, GB, GR, HR, HU, IE, IS, IT, LT, LU, LV, MC, MK, MT, NL, NO, PL, PT, RO, RS, SE, SI, SK, SM, TR), OAPI (BF, BJ, CF, CG, CI, CM, GA, GN, GQ, GW, ML, MR, NE, SN, TD, TG).

Published:

- with international search report (Art. 21(3))
- before the expiration of the time limit for amending the claims and to be republished in the event of receipt of amendments (Rule 48.2(h))

ELECTRICALLY OPERATED SHAVER WITH REPLACEABLE CUTTING DEVICE

FIELD OF THE INVENTION

The invention relates to an electric shaver according to the preamble of Claim 1 and a
5 replaceable cutting system for it.

BACKGROUND OF THE INVENTION

Electric shavers are known from DE 1 185 508 C and from DE 33 15 642 CI and from
DE 27 49 936 C3 in which, to produce a linear oscillating motion of the lower blade, an
10 oscillating bridge with resilient arms is provided which is connected via a gear mechanism to an
electric rotary motor. The gear mechanism preferably consists of a cam designed on a rotating
drive shaft of the motor which, according to DE 1 185 508 C, engages in a slot at the bottom of
the oscillating bridge, so that the rotational motion is transmitted to the oscillating bridge as an
oscillating motion.

15

In DE 33 15 642 CI and DE 27 49 936 C3, in contrast, the cam engages into an
alignment hole resilient lever on the oscillating bridge, so that, on the one hand, those
movements running perpendicular to the direction of displacement B (Fig. 1 of DE 33 15 642
CI) are absorbed by the bending of the resilient lever, and on the other hand, those movements
20 running in the direction of displacement B, are conveyed into the oscillating bridge, thus
reproducing this linear oscillating motion in the direction of displacement B according to Fig. 1.
This linear oscillating motion is transferred directly to the lower blade when the clutch is
engaged, which thus slides along the underside of a perforated upper blade. The resilient arms of
the oscillating bridge are mounted on the drive motor housing.

25

An electrically operated shaver is also known from DE 195 39 687 C2 in which two
oscillating bridges mounted in the housing, each with two resilient arms attached, one oscillating
bridge driving the lower blade of a first cutting device, preferably a short hair cutter, and the
other oscillating bridge driving the lower blade of another cutting device, preferably a linearly
30 oscillating trimmer. The oscillating bridges are firmly anchored in the motor housing.

An electrically operated shaver is also known from DE 43 CI 41 392 CI in which, to
achieve a linear oscillating motion, the cam engages into a groove formed in one of the two

resilient arms. Here again, the resilient arms are securely mounted to the motor housing of the shaver.

In all the aforementioned citations, the resilient arms are designed so that they typically
5 outlast the life of a shaver, that is, they must withstand millions of vibrations, so as not to cause premature failure of the shaver. For this reason, high quality materials are used in the oscillating bridge. This results in increased material costs. On the other hand, higher installation costs are incurred if, due to high load alternation, a defect occurs in the supporting arms of the oscillating bridge, necessitating its replacement.

10

The object of the invention is to now avoid the above disadvantages and to create a shaver and a replaceable cutting system for it which has is highly functional, cost effective, works quietly and at the same time delivers good shave results and its oscillating bridge can be easily replaced without major assembly costs.

15

SUMMARY OF THE INVENTION

According to the invention, this object is achieved by a shaver according to the characterizing features of Claim 1 and a replaceable cutting device for it, according to the characterizing features of Claim 14. As a result, now, according to the invention, with each
20 change of a used upper blade (very thin shaving foil and therefore often defective) or lower blade, the oscillating bridge is also replaced, thus renewing the oscillating bridge with its supporting resilient arms on which both the upper and the lower blade-bearing frames are mounted or arranged, also called a shaving cartridge.

25

The removable frame or shaving head cartridge with upper and lower blades and with integrated oscillating bridge is simply clipped into the shaving head, as is generally known in the prior art, wherein the clutch engagement on the motor side then engages with the oscillating bridge. Belonging to this kind of prior art are, for example, Shaver 70S (Series 7) or the "Pulsonic" shaver (Series 9000), produced and distributed by the applicant himself, which are
30 equipped with a shaving cartridge, which should preferably be changed every 18 months to provide a continuously optimum shave. The removable frame according to the invention can either be mounted in one place on a shaving head frame attached to a fixed shaver housing, or it

can also be pivotally mounted on a pivot frame, which in turn is pivotally mounted on a housing head support.

With the invention, now less high-strength materials and less constant flex resilient materials can be selected since the cutting device is replaced at given time intervals anyway. In this way, high repair costs are avoided. The invention can be used for all shavers marketed by the applicant, in which the upper and lower blades are incorporated as an integral part of the removable frame or of the shaving head cartridge.

Advantageously, the resilient arms with the oscillating bridge are essentially W-shaped in cross section, wherein the two outer legs form the resilient arms. This embodiment of oscillating bridge and resilient arms has proven to remain elastic especially long-term, which also results in simple production as an injection molded plastic part. This shape yields a symmetrical design, with the central axis passing through the intersection of the two inner legs. Because of the W-shape, the two outer resilient legs can be moved down sufficiently far from the blade to create enough space for the clutch to engage between the lower blade and the oscillating bridge and for the coupling of the gear mechanism to be arranged between the oscillating bridge and the drive unit. Although the clutch engagement between the lower blade and the oscillating bridge after mounting the removable frame always makes a solid connection, the clutch engages the oscillating bridge to the gear mechanism only when the removable frame, with upper and lower blade on the cutting head, is mounted or clipped to the shaving head of a shaver.

If the free ends of the resilient arms are joined to the removable frame as a single piece, the removable frame with the resilient arms can preferably consist of a plastic injection molded component. In this connection, the oscillating bridge itself could well be a stamped bending mold, which is joined to the resilient arms in a further manufacturing step, for example by welding, punching, riveting, bolting or the like.

If the oscillating bridge is integrally joined to the resilient arms, the removable frame can be formed as a single molded component both with the resilient arms and with the oscillating bridge. For this purpose, particularly cost effective injection tools are available, in the cavity of which a plastic material is injected to form the removable frame with the oscillating bridge and the resilient arms. Polyphenylene sulfide (PPS) has proven to be a particularly tough, durable,

and yet cost effective elastic material. Of course, other plastics are possible, but only if they meet the test requirements for such high frequency vibrating elastic arms and for frames of this type.

5 It is advantageous that the removable frame form a single component with the upper blade and lower blade and with the resilient arms and the oscillating bridge, that this component be detachably secured to a pivot frame, that the pivot frame be pivotally mounted on a head carrier and that the head support be part of a shaver housing. In this way, a shaver is produced having a pivot frame on the head support, into which the cutting unit is integrated, and which is
10 detachably joined to enable it to be quickly and easily replaced or to be quickly disassembled for cleaning. But of course, the invention can also be arranged in a head support that is fixed on the housing of a shaver. By pivoting the pivot frame in which its pivot axis is parallel to the linear oscillating motion of the lower blade, especially good shave results are obtained because the perforated foil-like upper blade can optimally follow the contour of the skin surface.

15

 In order to create a simple drive connection from the drive motor to the oscillating bridge, both the head support and the pivot frame are penetrated by a drive member having a longitudinal slot on the lower end into which a cam (4) engages, and the protruding end of the pivot frame (28) engages in a receptacle (41). The cam forms the gear mechanism for the cutting
20 device in the removable frame with the drive member and its engagement with the oscillating bridge.

 A further embodiment of the invention provides that the gear mechanism and the clutch engagement be connected with one another by a rocker arm and that the rocker arm be pivotally
25 mounted about a rotational axis. This additional arrangement according to the invention makes it possible for the resilient arms connected to the oscillating bridge to be shorter. This results in a lower space requirement. By using the rocker arm, the displacement path of the lower blade can be achieved with particularly small-scale cam design in the gear mechanism.

30 When the rotation axis is on the central axis of the rocker arm, the result is an absolutely even movement between the left and right sides of the rocker arm and thus also on the lower blade.

If the axis of rotation intersects at that point of the central axis of the rocker arm at which the central or longitudinal axes of the resilient arms intersect in the idle position of the shaver, there is no relative movement of the rocker arm on the clutch engagement between the oscillating bridge and the lower blade. In this way, the smallest bending deformations also occur
5 on the resilient arms, which optimizes the dynamic fatigue behavior of the resilient arms.

It is advantageous for the axis of rotation of the rocker arm to run perpendicular to the linear oscillating motion of the lower blade so that a symmetrical component results. At the same time, the frictional losses should be as low as possible in the moving components, such as
10 in the clutch engagement and gear mechanism. It is advantageous for the axis of rotation to be formed, on the one hand, by a borehole through the rocker arm and, on the other hand, by an alignment pin sliding through the hole, wherein the alignment pin is mounted on the pivot frame.

In a preferred embodiment, the invention relates not only to an electric shaver, but also to
15 a replaceable cutting device, which is tradable as a spare for such a shaver. Because of the removable cutting device according to the invention, complex repairs and the necessarily associated high repair costs are avoided.

It is advantageous if the oscillating bridge with the resilient arms is integrally joined as one piece with the removable frame. In this way, the removable frame with the oscillating
20 bridge can be produced extremely inexpensively as a separate injection molded plastic part.

BRIEF DESCRIPTION OF THE DRAWINGS

Several embodiments of the invention are shown in the drawings and are clarified in more detail below. In the drawings:

25

Fig. 1 is a perspective sketch of a head support with pivot frame with a raised framework with integrated upper and lower blade and oscillating bridge, but in a greatly enlarged scale,

Fig. 2 is an large scale partial longitudinal section through the configuration according to the
30 invention with the oscillating bridge in the initial position; only the parts characterized in the invention are shown roughly sketched,

Fig. 3 shows a large scale, slightly perspective view from right front of the oscillating bridge with the rocker arm and cam shaft in the initial position of the shaver,

Fig. 4 is a perspective sectional view of Fig. 3, but from approximately half-right and slightly
5 from above and

Fig. 5 is a slightly perspective view from right front of the oscillating bridge and the rocker arm with cam shaft corresponding to Fig. 3, wherein, however, the rocker arm is rotated counter-clockwise around the rotational axis D so that the clutch member has taken a left-shifted position
10 due to the elastic deformation of the oscillating bridge.

DETAILED DESCRIPTION OF THE INVENTION

According to Fig. 2, on an electric drive motor (partially shown) in a housing 1 (shown only to some extent) of a shaver (not shown in detail), is a drive shaft 3 with a cam 4 protruding
15 from the upper side. The cam 4 engages in a longitudinal slot 5 running perpendicular to the plane of projection on the lower free face-end of a rocker arm 6. Above the longitudinal slot, the rocker arm 6 swivels easily about a rotational axis D through angle α (figure 5), counter-clockwise in the plane of projection.

20 According to figures 3 through 5, the rocker arm 6 is formed in two parts, wherein the lower section is formed by a sleeve 7, on the lower free end of which the longitudinal slot 5 is configured. The sleeve 7 has a central longitudinal borehole 55, into which a pin 8, preferably metal, is pressed. The upper free end of the cylindrical pin 8, according to Figures 2 through 5,
25 is preferably flattened on both sides and engages flush in another longitudinal slot 9 which is formed in the center of an oscillating bridge 10. The flattened areas form lateral flattened sides 11, 12 which run parallel to walls 13, 14 of the other longitudinal slot 9, according to Fig. 3 through 5. Symmetrical to the longitudinal axis 15 of pin 8 at the upper end, a slot 16 open towards the free end is introduced, which divides the free end of the rocker arm 6 into two bars 17, 18. The two bars 17, 18 slide along walls 13, 14 of the other longitudinal slot 9 with
30 virtually no play and easily can absorb sudden shocks elastically.

As Figures 3 through 5 also show, the oscillating bridge 10 with its resilient arms 19, 20 formed at its free ends is essentially W-shaped in cross-section. At their free ends, the resilient

arms 19, 20 have thickened horizontal sections 21, 22 opposite the resilient arms 19, 20 preferably formed as strips and joined to a removable frame 23, for example, by adhesion or welding, etc., as shown in Figure 1. However, sections 21, 22 can also preferably be joined as one piece with the removable frame 23 by being molded in an injection mold together with the
5 removable frame 23.

As Figures [sic, translator] 3 further shows, at rest the resilient arms 19, 20 extend straight along the longitudinal axes 53, 54. If the longitudinal axes 53, 54 are lengthened down beyond resilient arms 19, 20, they intersect at or near pivot point D on the longitudinal axis 15 of
10 the rocker arm 6. Resilient arms 19, 20 form an angle β of 15° to 60° , preferably 30° , with longitudinal axis 15.

The oscillating bridge 10 itself is V-shaped and is formed by two inner legs 49, 50, on the connecting point of which on one side the coupling members 42, 43, 44 are arranged and on the
15 other, bottom side, the receptacle is designed as a longitudinal slot 9. In Figures 2 through 5, the fork-shaped pivot frame 28 and the head support 24, as shown in Figure 1, are not shown for simplicity. Only one section of the shaver housing 1 is indicated in Figure 2.

Fig. 1 shows the head support 24, which is forked and on its fork-shaped rods 25, 26 a
20 likewise forked pivot frame 28 is pivotally mounted about a pivot axis 27 at predetermined limits. The head support 24 is part of a housing of a shaver, not shown in Fig. 1 but indicated in Fig. 2, in which the drive motor 2 and all electrical components (not shown) are integrated. Both the head support 24 and the middle section 29 of the forked pivot frame 28 are penetrated by mutually aligned holes 30, 31, forming a common longitudinal axis 15. The holes 30, 31 are
25 penetrated by a drive shaft 32 which at its lower end (not shown) preferably has a longitudinal slot 5, likewise according to Figures 3 through 5, connected with the cam 4 of drive shaft 3 of a drive motor 2. With the aid of this gear mechanism, the upper end of the drive shaft 32 performs a linear oscillating motion in direction B.

30 According to Fig. 1, above the pivot frame 28 is a removable frame 23, which is delimited from above and outside by at least one convexly curved perforated foil 33. The shaving foil 33 has many small holes 34, only some of which are vaguely indicated. On the underside 35 of the shaving foil 33 closely spaced adjacent blades 37 lie on the peripheral

surfaces 38 perpendicular to the direction of displacement B. Again, only a small portion of lower blade 36 is vaguely indicated. The lower blade 36 is guided in removable frame 23 in the guide direction B over guide elements, not shown. Rods 39, 40 protrude downward from the removable frame 23 on which sections 21, 22 of the resilient arms 19, 20 are arranged. In the center, oscillating bridge 10 formed as a unit with the resilient arms 19, 20, has a downwardly open receptacle 41, into which the free end of the drive shaft 32 engages in the assembled state of the removable frame 23 on the pivot frame 28.

According to Figures 3 through 5, in the middle near the top of the oscillating bridge 10, three coupling members 42, 43, 44 arranged in a row behind one another engage without clearance in corresponding receptacles of three lower blades (not illustrated). This is the case if the removable frame 23 is provided with three adjacent cutting devices simultaneously driven to oscillate over the common swing bridge. This is the case, for example, with the 70S (Series 7) or "Pulsonic" (Series 9000) shavers marketed by the applicant. According to Fig. 1, the removable frame 23 is joined to the pivot frame 28 with locking elements (not shown), but is still removable.

Fig. 2 additionally shows how the lower blade 37, for example, can be joined with a coupling member 42. For this purpose, a shaped spring 47 is hinged at two pivot points 45, 46 on the bottom blade 37, the centrally positioned spherical cap 48 of which pivotally engages coupling member 42 joined to swing bridge 10.

Fig. 5 shows a sketch of approximately how the resilient arms 19, 20 can deform when the rocker arm 6 is swiveled through the angle α counterclockwise about its rotational axis D. On the return stroke, the same angle is reached to the right of longitudinal axis 15, corresponding to the maximum amplitude of oscillating bridge 10. The length of the other longitudinal slot 9 indicates the size of the pivot angle of removable frame 23.

As only suggested in Fig. 2, the bearing of the rocker arm 6 in D is designed as a hole 51 in the rocker arm perpendicular to the plane of projection, in which a pin or peg 52 engages without clearance. The pin 52 is fixed to the shaver housing 1 or to some other stationary part of the shaver. Instead of a hole 51 in the rocker arm 6, pin 52 (not shown) may also extend out of

the rocker arm on both sides, which engage in holes formed in the housing 1 (not shown). Of course, in this connection other embodiments of bearings are also conceivable.

Finally, please note that the same reference numbers were selected for identical parts in Figures 1
5 through 5.

The dimensions and values disclosed herein are not to be understood as being strictly limited to the exact numerical values recited. Instead, unless otherwise specified, each such dimension is intended to mean both the recited value and a functionally equivalent range surrounding that
10 value. For example, a dimension disclosed as "40 mm" is intended to mean "about 40 mm."

CLAIMS

What is claimed is:

1. An electrically operated shaver with at least one upper blade (33) attachable to a shear head frame (24) by means of a removable frame (23), on the underside (35) of which lies a linearly oscillating lower blade (36) connected via a clutch engagement (48, 42) with an oscillating bridge (10) mounted on the shaver on either side by resilient arms (19, 20) and connected to the drive shaft (3) of an electric motor (2) via a gear mechanism (41, 6, 5, 4), so that when the motor (2) is running, the oscillating bridge (10) and thus also the lower blade (36) is set into linear reciprocating movement, **characterized in that** the resilient arms (19, 20) of the oscillating bridge (10) are configured on the removable frame (23).
2. The shaver according to Claim 1, **characterized in that** the resilient arms (19, 20) with the oscillating bridge (10) are essentially W-shaped in cross section, wherein the two outer legs (19, 20) form the resilient arms and the two inner legs (49, 50 or 42) form the oscillating bridge (10).
3. The shaver according to Claim 1, **characterized in that** the free ends (21, 22) of the resilient arms (19, 20) are integrally joined to the removable frame.
4. The shaver according to Claim 1, **characterized in that** the oscillating bridge (10) is integrally joined to the resilient arms (19, 20).
5. The shaver according to Claim 3 and/or 4, **characterized in that** the resilient arms (19, 20), the oscillating bridge (10) and the removable frame (23) are preferably formed of polyphenylene sulfide (PPS).
6. The shaver according to Claim 1, **characterized in that** the resilient arms (19, 20) are secured to the removable frame (23).
7. The shaver according to Claim 1, **characterized in that** the removable frame (23) with the upper and lower blade (33, 36) and with the resilient arms (19, 20) and the oscillating bridge (10) form a structural unit, that the structural unit is detachably secured to a pivot frame (28), that the pivot frame (28) is pivotally mounted on a head support (24) and that the head support (24) is part of a shaver housing (1).

8. The shaver according to Claim 7, **characterized in that** both the head support (24) and the pivot frame (28) are penetrated by a connecting member (32), that the lower end has a longitudinal slot (5) into which a cam (4) engages and that the end protruding from the pivot frame (28) engages into a receptacle (41).
- 5 9. The shaver according to Claim 8, **characterized in that** the connecting link is formed by a rocker arm (6) and that the rocker arm (6) is mounted to be capable of pivoting around an axis of rotation (D).
- 10 10. The shaver according to Claim 9, **characterized in that** the rotational axis (D) lies on the central axis (15) of the rocker arm (6).
11. The shaver according to Claim 10, **characterized in that**, when the shaver is at rest, the rotational axis (D) is designed to be at the point on the axis of symmetry (15) of the
15 rocker arm (6) at which the extensions of the longitudinal axes (53, 54) of the resilient arms meet.
12. The shaver according to Claim 11, **characterized in that** the rotational axis (D) runs perpendicular to the linear oscillating motion (B) of the lower blade (36).
- 20 13. The shaver according to Claim 12 **characterized in that** the rotational axis (D) is formed on one side by a hole (51) passing through the rocker arm (6) and on the other side by an alignment pin (52) sliding through the hole (51), wherein the alignment pin (52) is secured to the pivot frame (23).
- 25 14. A removable cutting device for an electrically driven shaver consisting of at least one upper and lower blade (33, 34) in a removable frame (23) wherein the lower blade (36) is attached to an oscillating bridge via a clutch (45), which in turn is coupled via a gear mechanism (41, 6, 5, 4) to an electric drive (2), wherein the oscillating bridge (10) is
30 connected to the shaver by means of resilient arms (19, 20), **characterized in that** the resilient arms (19, 20) of the oscillating bridge (10) are secured to the removable frame (23).
15. A removable cutting device according to Claim 14, **characterized in that** the resilient arms (19, 20) with the oscillating bridge (10) are integrally joined to the removable frame (23).

1 / 3

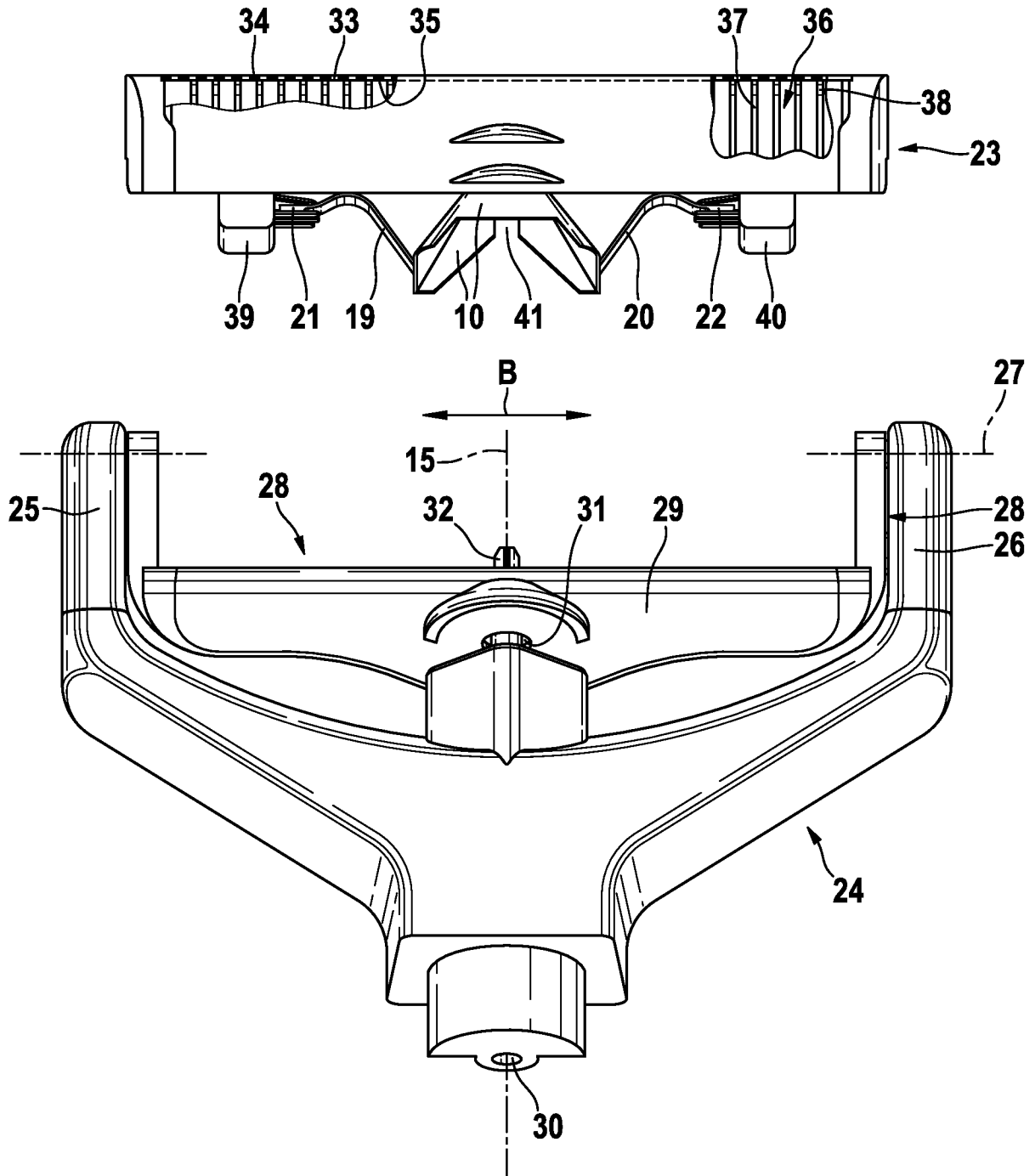

Fig. 1

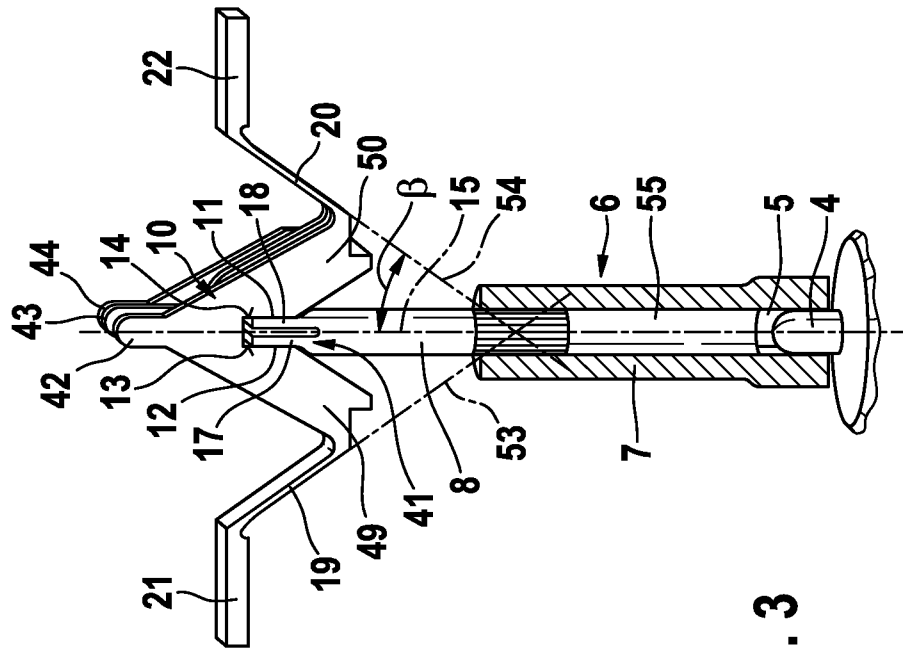

Fig. 3

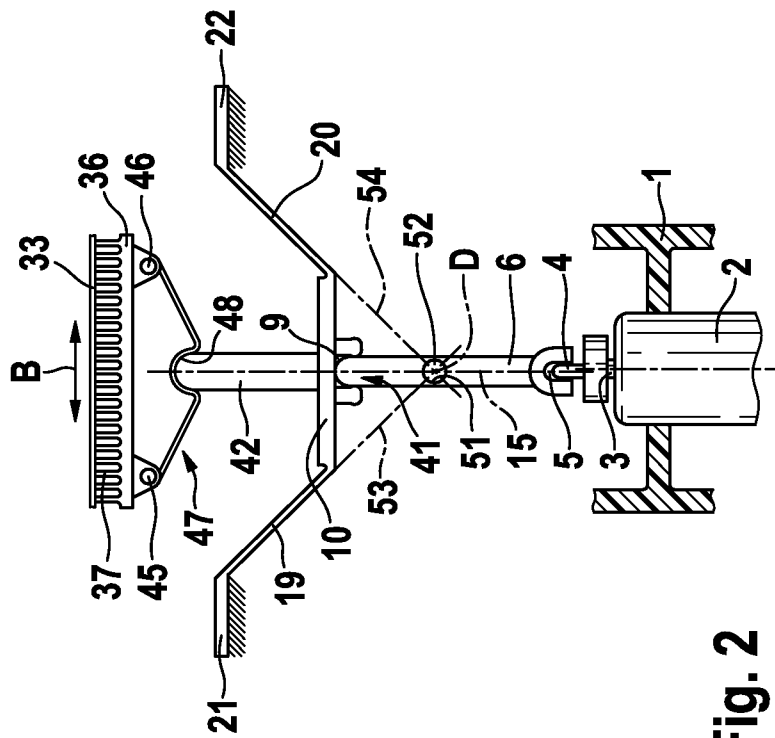

Fig. 2

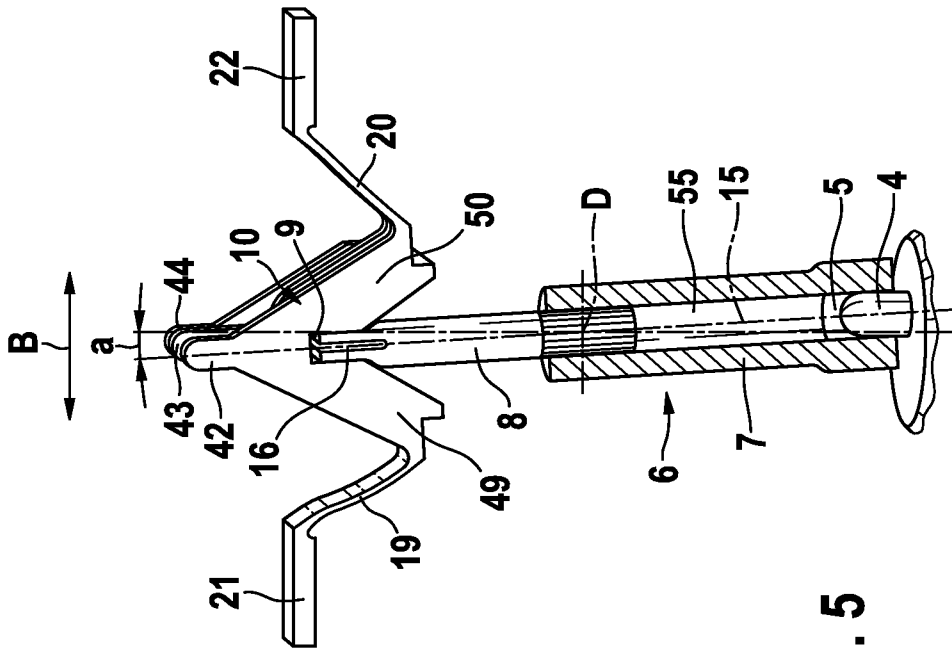

Fig. 5

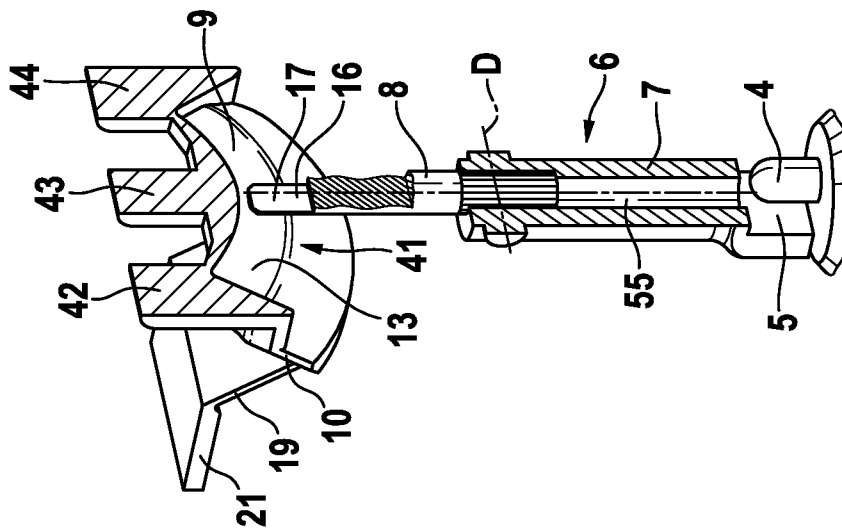

Fig. 4

INTERNATIONAL SEARCH REPORT

International application No
PCT/IB2011/053023

A. CLASSIFICATION OF SUBJECT MATTER
INV. B26B19/04 B26B19/28 B26B19/38
 ADD.
 According to International Patent Classification (IPC) or to both national classification and IPC

B. FIELDS SEARCHED
 Minimum documentation searched (classification system followed by classification symbols)
B26B

Documentation searched other than minimum documentation to the extent that such documents are included in the fields searched

Electronic data base consulted during the international search (name of data base and, where practical, search terms used)
EPO-Internal

C. DOCUMENTS CONSIDERED TO BE RELEVANT

Category*	Citation of document, with indication, where appropriate, of the relevant passages	Relevant to claim No.
X	FR 2 240 612 AI (DEFIM [FR]) 7 March 1975 (1975-03-07) page 4, line 2 - page 5, line 36; figures 6,8	1,2,6, 14
X	DE 43 03 972 CI (BRAUN AG [DE]) 14 October 1993 (1993-10-14)	1,4-6, 14
Y	col umn 3, lines 17-45; figures 1,2	2,3,15
Y	US 4 030 573 A (BUZZI LEO ET AL) 21 June 1977 (1977-06-21) col umn 1, lines 62-65 col umn 3, lines 37-50; figures 1,3	2
Y	DE 44 18 644 AI (MATSUSHITA ELECTRIC WORKS LTD [JP]) 1 December 1994 (1994-12-01) col umn 5, lines 37-41; figures 1,6	3,15
	-/- .	

Further documents are listed in the continuation of Box C. See patent family annex.

* Special categories of cited documents :

"A" document defining the general state of the art which is not considered to be of particular relevance	"T" later document published after the international filing date or priority date and not in conflict with the application but cited to understand the principle or theory underlying the invention
"E" earlier document but published on or after the international filing date	"X" document of particular relevance; the claimed invention cannot be considered novel or cannot be considered to involve an inventive step when the document is taken alone
"L" document which may throw doubts on priority claim(s) or which is cited to establish the publication date of another citation or other special reason (as specified)	"Y" document of particular relevance; the claimed invention cannot be considered to involve an inventive step when the document is combined with one or more other such documents, such combination being obvious to a person skilled in the art.
"O" document referring to an oral disclosure, use, exhibition or other means	"&" document member of the same patent family
"P" document published prior to the international filing date but later than the priority date claimed	

Date of the actual completion of the international search 28 October 2011	Date of mailing of the international search report 07/11/2011
---	---

Name and mailing address of the ISA/ European Patent Office, P.B. 5818 Patentlaan 2 NL - 2280 HV Rijswijk Tel. (+31-70) 340-2040, Fax: (+31-70) 340-3016	Authorized officer Rattenberger, B
--	--

INTERNATIONAL SEARCH REPORT

International application No
PCT/IB2011/053023

C(Continuation). DOCUMENTS CONSIDERED TO BE RELEVANT		
Category*	Citation of document, with indication, where appropriate, of the relevant passages	Relevant to claim No.
X	us 4 003 131 A (GROOTHUIS GERRIT JAN) 18 January 1977 (1977-01-18) col umn 2, lines 10-49 ; figures 1,2 -----	1, 14

INTERNATIONAL SEARCH REPORT

Information on patent family members

International application No PCT/IB2011/053023
--

Patent document cited in search report	Publication date	Patent family member(s)	Publication date
FR 2240612	AI	07-03-1975	NONE
DE 4303972	CI	14-10-1993	JP 3514795 B2 31-03-2004
			JP 6269577 A 27-09-1994
			US 5410811 A 02-05-1995
US 4030573	A	21-06-1977	AT 334245 B 10-01-1976
			CA 1030748 AI 09-05-1978
			DE 2558783 AI 15-07-1976
			FR 2297361 AI 06-08-1976
			GB 1536032 A 20-12-1978
			JP 51098558 A 30-08-1976
			JP 58130666 U 03-09-1983
DE 4418644	AI	01-12-1994	JP 3528201 B2 17-05-2004
			JP 6335572 A 06-12-1994
			US 5490328 A 13-02-1996
US 4003131	A	18-01-1977	AT 333618 B 10-12-1976
			CA 1018338 AI 04-10-1977
			CH 583610 A5 14-01-1977
			DE 2513009 AI 09-10-1975
			FR 2266577 AI 31-10-1975
			GB 1497880 A 12-01-1978
			JP 50136148 A 29-10-1975
			NL 7404655 A 07-10-1975