

May 2, 1961

W. H. SCHWAB

2,981,987

JALOUSIES AND WEATHER SEALING MEANS THEREFOR

Filed July 7, 1954

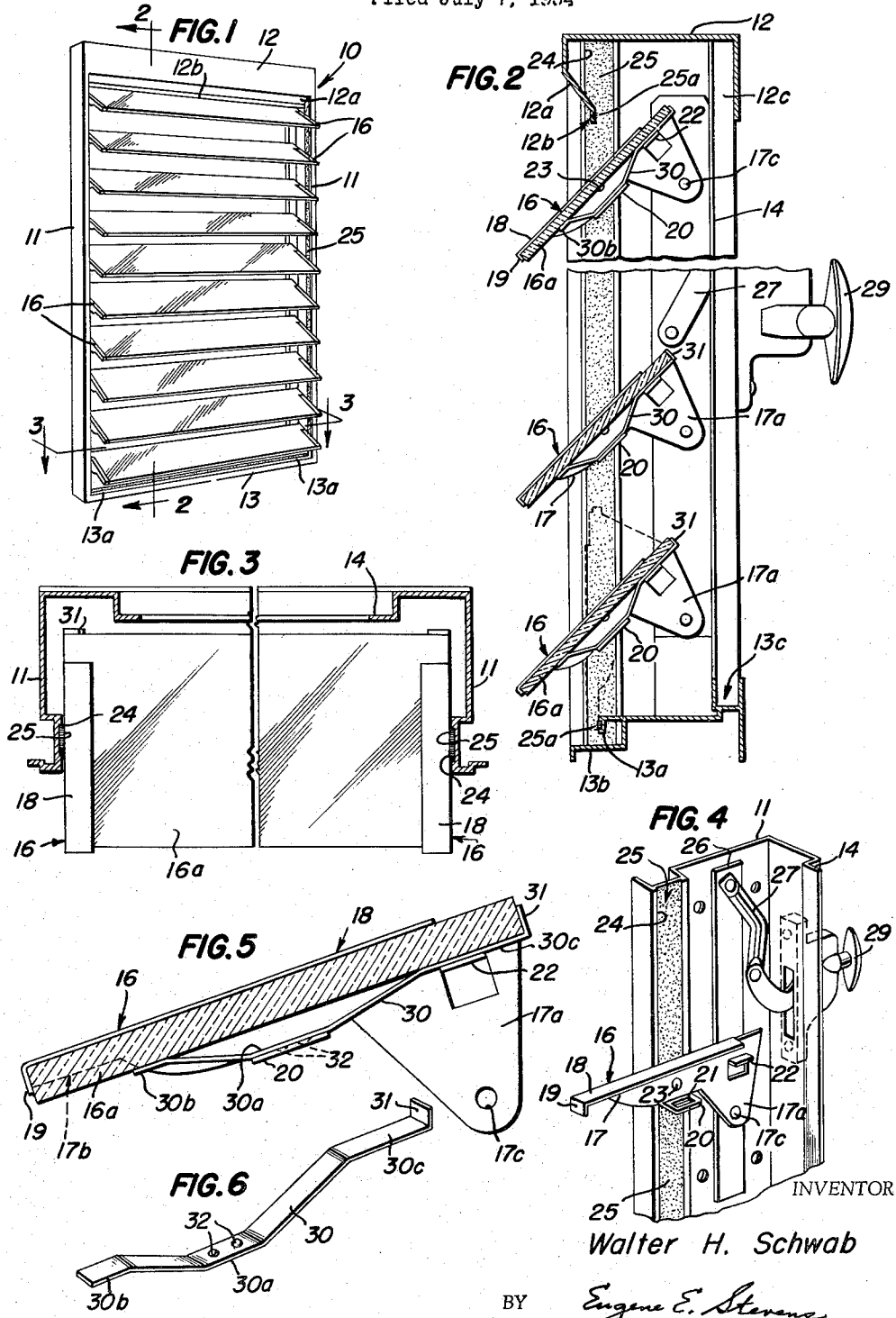

INVENTOR
Walter H. Schwab

BY Eugene E. Stevens
His ATTORNEY

1

2,981,987

JALOUSIES AND WEATHER SEALING MEANS THEREFOR

Walter H. Schwab, 3855 N. Miami Ave., Miami, Fla.

Filed July 7, 1954, Ser. No. 441,795

2 Claims. (Cl. 20-62)

My invention relates to improvements in jalousies, which are employed for light and ventilation control, etc., and include multiple frame-carried louvers.

Briefly and generally stated, one of the primary objects of the invention is to provide means for effecting a seal between the louvers and the carrying frame when the louvers are closed, and wherein seal-effecting means at the site of the jamb, or side portions of the jalousie frame, function to urge bracket-form end carriers against the louver ends, when such carriers are used.

Additionally, the invention contemplates the provision of novel bracket-form carriers for pivotally supporting the louver ends and which incorporate novel means for removably retaining glass or other louver panels in assembly therewith and against relative transverse movement therein.

Still further features of the invention include the employment of novel weather stripping and frame-provided carrier portions therefor, so arranged in relation to the louvers as to not only effect a seal between all abutting frame and louver portions when the latter are closed, but also to assure a smooth, easy and quiet rattleless operation of the louvers.

Various other objects and advantages of the invention will be apparent later on to those versed in the art, it being emphasized that the invention also resides in certain novel features of construction, combination and arrangement of the various parts and in modes of operation thereof, as will be understood and appreciated from a reading of the following descriptive matter in conjunction with the accompanying drawing.

Although the drawing, as required by the patent statute, discloses a now preferred example of my inventive concept, it is to be understood that same is susceptible of other mechanical expressions within the spirit and scope of the subject matter claimed hereinafter.

In the drawing, wherein the same reference characters have been used to designate the same parts throughout the several views:

Fig. 1 is a perspective view of a frame-incorporating jalousie unit embodying my invention;

Fig. 2 is a vertical sectional view taken on the line 2-2 of Fig. 1;

Fig. 3 is a horizontal sectional view through the jalousie frame and looking down on a horizontally disposed louver;

Fig. 4 is a perspective view of one of the pivoted bracket-form louver panel carriers and related jamb portion of the jalousie frame;

Fig. 5 is a cross-sectional view through one of the louver panels and showing the bracket form carrier applied at one end thereof; and

Fig. 6 is a perspective view of a spring form louver panel-retainer which is associated with the bracket-form carrier as shown in Fig. 5.

Referring to the drawing by reference characters, numeral 10 designates the jalousie frame and includes the

2

jamb or side portions 11, the head portion 12, and the sill 13.

Figs. 2, 3 and 4 disclose the jamb portions 11 of the frame as providing the rear inwardly extending seating flanges 14 for a screen frame (not shown); and Fig. 2 discloses the head and sill portions 12, 13 of the frame as providing the rear seating recesses 12c, 13c for a screen frame. The jalousie frame 10 therefore serves a dual function in that it not only carries the horizontally pivoted louvers 16 but also provides a mount for a screen.

Also, as indicated in Figs. 1 and 2, the head portion 12 of the frame has its depending frontal portion which is inwardly inclined as indicated at 12a, terminating in a louver-engaging buffer 12b. The inner louver-engaging surface of the buffer or stop 12b has a covering of weatherstrip material 25b which takes the form of a novel flocking-like body which will be referred to later on herein.

As illustrated in Fig. 2, the sill member 13 has above its downwardly offset forward bottom portion 13b the forwardly extending and longitudinally coextensive buffer portion 13a against which the inner surface of the lower louver 16 engages when the louvers are closed, it being noted that the buffer 13a has the fibrous material or weatherstrip-like facing 25a which is also preferably of the flock-like material referred to in connection with the head-provided buffer 12b. Additional reference will be made later on herein to the compressible material faced buffer portions 12b, 13a in conjunction with the compressible jamb-carried weather sealing means 25 which is shown in Figs. 2, 3 and 4, and also in Fig. 1.

Although the jalousie frame 10 will preferably be made of metal, as indicated in the drawings, it may nevertheless, be of wood or other material.

In the illustrated embodiment of the invention, the louver panels 16a are of glass or the like, and have their ends supported in pivoted bracket-form carriers which are generally designated by reference character 16 and are pivotally supported as at 23 by the jamb portions 11 of the frame 10.

Referring particularly to the bracket-form louver carriers 16, it will be noted that each comprehends the plate-like side portion 17, the top or outer edge of which has the inwardly extending flange 18 which overlies the outer surface of the louver panel 16a as indicated in Figs. 2 and 5.

This flange 18 has its forward end bent inwardly as at 19 to abut the lower edge portion of the louver panel 16a when the outer surface of such panel is adjacent the inner surface of flange 18, as indicated in Fig. 5.

As will be noted from an inspection of Figs. 2, 4 and 5, the intermediate portion of the side 17 of carrier 16 is of a width substantially exceeding the thickness of the louver panel 16a while the rear or upper end of carrier 16 is provided by the coplanar rearwardly extending ear portion 17a which is apertured as at 17c to receive the pin of an operating member.

The forward or lower end of the carrier side 17 may be of reduced width as indicated at 17b, so as to facilitate overlapping of the louver panels 16a when they are closed against one another, as will be understood from an inspection of Figs. 1 and 2.

In further carrying out the invention, the intermediate side portions of the carrier sides 17 have the inwardly extending seat-providing flange 20 which is disposed substantially outwardly of the plane of the seated louver panel 16a as will be noted in Fig. 5, the seat of the flange 20 taking the form of a slot 21 as indicated in Fig. 4, the purpose of which will be presently explained.

The rear or upper portion of the seated louver or panel 16a is supported by the flange 22 which is struck inwardly

from the ear portion 17a of the carrier and is spaced from the plane of the inner surface of the outer carrier flange 18 a distance slightly greater than the thickness of the louver or panel 16a.

Each bracket-form carrier 16 receives a pivot pin 23 through a hole in its flange portion 17, such pivot pin 23 extending from the mid-portion of a channel or groove 24 in the inner forward portion of the related jamb portion 11 of the frame 10. The compressible flocking or weatherstrip-providing material 25 referred to incidentally herein, is disposed in and projects from the groove 24 so as to effect a seal between the frame and the adjacent carrier member 16 when the louvers are closed; and also, at all times, to tend to urge the inner surfaces of the carrier sides against the opposed ends of the related louver panels 16a. Thus, any rattle between carrier and louver is prevented and quiet, easy operation of the louvers by the usual operating member 25 is achieved.

Regarding the operating member 29, which is indicated in Figs. 2 and 4, it will be noted that it has the usual connection 27 with the vertically movable strip or bar member 26 which latter establishes the pivot connections 25 with the ear portions 17a of the respective bracket-form carrier members 16 at the site of at least one of the jamb portions 11 of the frame 10. The louver operating means is, or may be, conventional, and no novelty is claimed therefor.

Referring back to the assembly of the louver panels 16a in the bracket-form end carrier 16, the two end carriers 16 being in place for a particular panel 16a, the latter is slid upwardly or rearwardly on the opposed seat-providing flanges 20 as supports until the forward or outer end of the panel can be seated against the downturned portion 19 of flange 18, at which time the rear or upper portion of the panel 16 will be resting upon the inwardly turned flanges 22 of the opposed carrier ears 17a. Now the novel spring form clip or retainer 30 of Fig. 6 is applied to each of the panel-supporting carriers 16 as will be understood from an inspection of Figs. 2 and 5.

Referring to the panel retainer 30 of Fig. 6, it will be noted that it is of arched spring form and that its intermediate portion 30a has the two outwardly projecting dimples or rounded studs 32 which are adapted to seat in the slot 21 of flange 20, so that the end portions 30b, 30c will make firm bearing contact with the inner surface of panel 16a, so as to force it against the overlying end flanges 18 of the carrier members 16. The portion 30c of the member 30 overlies the ear carried flange 22; and as will be noted, the adjacent end of the retainer member 30 is inturned as at 31 to overlie the rear or upper edge of the panel 16a so as to force the lower or forward edge thereof against the inturned portions 19 of the related carrier flanges 18. Longitudinal shifting of retainer 30 is prevented by the engagement of 32, 32 in 21.

If, for any reason, it is desired to remove one of the louver panels 16a from its end carriers 16 it is only necessary to compress the arched retainers 17 while holding the panel against the adjacent carrier end flange 18 and then shift the retainer 30 laterally to disengage the retainer from the related ear flange 22. The louver or panel 16a can then be removed after the retainer 30 at each end has been displaced.

The compressible flocking material 25 in the jamb grooves 24 tends to force the end carriers 16 against the related panel ends to avoid looseness at such points, and, of course, the outer surfaces of the carriers bearing as they do against the compressible material 25 have an easy soundless swinging movement when 29 of Fig. 4 is operated. Additionally, the compressible weatherstrip-like facing 25a, 25a which is carried by the buffer portions 12b, 13a of the head and sill portions makes for an effective top and bottom seal between the louvers and the head and sill portions of the frame when the louvers are closed.

By preference the weatherstrip-like compressible and

sealing material 25, 25a takes the form of a flocking-like material which comprehends short resilient hairs closely spaced to one another and having outwardly projecting free ends, the inner ends thereof being adhered to the head or sill provided buffer portions 12b, 13a, or to the backs of the shallow grooves 24 of the jamb portions 11. Such grooves 24 function to confine the material 25 against lateral shifting so that the hairs or bristles will be held compacted against one another to always exert a resilient pressure against the outer surface of the side flanges 17 of the bracket-form carrier members 16.

From the foregoing, it is believed that the advantages of my development will be readily understood and appreciated. Although the flocking material 25, 25a is preferred, other form of weatherstrip-providing material can be used; and as mentioned earlier, other departures from the illustrated details can be resorted to.

Having thus described my invention, what I claim is:

1. In a jalousie providing opposed frame provided jambs and a plurality of parallel louver form panels, a separable, assembly and disassembly-facilitating, and rattle-preventing bracket form end carrier for supporting and firmly gripping the opposite ends of individual louver panels, the carriers admitting of related panels to be conveniently rocked into assembly therewith from the rear; each of the carriers providing a panel end-engaging outer side wall and jamb-supported pivot studs carried thereby, an inwardly extending flange carried by each carrier side wall and overlying the forward major outer surface portion of the related panel adjacent its end, each flange terminating well short of the rear end of said carrier side wall and having an inwardly turned stop-providing forward end portion abutting the forward longitudinal edge of said panel when the latter is operatively in place in the carrier, the intermediate and rear portions of each carrier side wall being of a width exceeding the thickness of the related panel and providing an inwardly extending panel-supporting shoulder adjacent its rear end and spaced from the plane of the opposed surface of said flange, the intermediate portion of said carrier side wall having an inwardly extending shoulder spaced from the panel-overlying flange a distance substantially greater than the thickness of said panel, a detachable leaf spring having intermediate its ends an outwardly arched portion which latter is supported by the inner surface of said last mentioned carrier shoulder interengageable anchoring means in part provided by said arched spring portion and in part by said second-mentioned shoulder, a laterally projecting stop at the rear spring end and engaging the rear panel edge whereby to cooperate with the flange end stop to retain the panel against edgewise shifting, said leaf spring adjacent to its rear end being interposed between said panel and said first mentioned shoulder, the spacing between said first mentioned shoulder and said flange approximating the composite thickness of the panel and leaf spring, the second mentioned shoulder spaced from said flange a greater distance than said first shoulder but less than the depth of the intermediate arched portion of said spring, whereby said spring can be slid sidewardly into operative position so that the spring and first shoulder cooperate with the second shoulder and said anchoring means to support the panel in non-shifting and substantially non-rattling engagement with said flange and to retain said spring-provided stop in operative position, and the rear end of each flange of related carriers providing a fulcrum about which the related panel is rocked while being slid rearwardly into place with the forward flange end-provided stops in engagement with the forward panel edge so as to support the weight of the panel when the carriers and panel are in vertical position pending the aforementioned sideward actuation of the leaf spring to its operative position.

2. The structure set forth in claim 1, and said anchoring means comprising an elongated second shoulder-

5

provided inner surface recess closed at its sides and ends and extending longitudinally of the carrier, and spring carried lug means projecting into said recess adjacent opposite ends of the recess whereby to prevent both end-wise shifting and sidewise shifting or rocking of the spring parallel with the plane of said second shoulder.

2,345,273
2,530,708
2,565,447
2,607,585
2,649,629
2,654,921
2,716,786
2,766,494

6

Macklanburg ----- Mar. 28, 1944
Loewenthal et al. ----- Nov. 21, 1950
Andresen et al. ----- Aug. 21, 1951
Hashimoto ----- Aug. 19, 1952
Baxter et al. ----- Aug. 25, 1953
Blanchard ----- Oct. 13, 1953
Moore ----- Sept. 6, 1955
Stremmel ----- Oct. 16, 1956

References Cited in the file of this patent

UNITED STATES PATENTS

921,854 Lindemann ----- May 18, 1909 10