



- (51) International Patent Classification:
G01R 1/04 (2006.01)
- (21) International Application Number:
PCT/MY2011/000058
- (22) International Filing Date:
27 May 2011 (27.05.2011)
- (25) Filing Language: English
- (26) Publication Language: English
- (71) Applicant (for all designated States except US): **JF MICROTECHNOLOGY SDN. BHD.** [MY/MY]; Lot 6, Jalan Teknologi 3/6, Taman Sains Selangor 1, Kota Damansara, Petaling Jaya, Selangor 47810 (MY).
- (72) Inventor; and
- (75) Inventor/Applicant (for US only): **FOONG, Wei Kuong** [MY/MY]; No. 3, Jalan TR 9/1, Tropicana Golf & Country Resort, Petaling Jaya, 47410 Selangor (MY).
- (74) Agent: **TOONG, Jo-Han**; A-5-10 Empire Tower, SS16/1 Subang Jaya, 47500 Selangor (MY).
- (81) Designated States (unless otherwise indicated, for every kind of national protection available): AE, AG, AL, AM, AO, AT, AU, AZ, BA, BB, BG, BH, BR, BW, BY, BZ,

CA, CH, CL, CN, CO, CR, CU, CZ, DE, DK, DM, DO, DZ, EC, EE, EG, ES, FI, GB, GD, GE, GH, GM, GT, HN, HR, HU, ID, IL, IN, IS, JP, KE, KG, KM, KN, KP, KR, KZ, LA, LC, LK, LR, LS, LT, LU, LY, MA, MD, ME, MG, MK, MN, MW, MX, MY, MZ, NA, NG, NI, NO, NZ, OM, PE, PG, PH, PL, PT, RO, RS, RU, SC, SD, SE, SG, SK, SL, SM, ST, SV, SY, TH, TJ, TM, TN, TR, TT, TZ, UA, UG, US, UZ, VC, VN, ZA, ZM, ZW.

(84) Designated States (unless otherwise indicated, for every kind of regional protection available): ARIPO (BW, GH, GM, KE, LR, LS, MW, MZ, NA, SD, SL, SZ, TZ, UG, ZM, ZW), Eurasian (AM, AZ, BY, KG, KZ, MD, RU, TJ, TM), European (AL, AT, BE, BG, CH, CY, CZ, DE, DK, EE, ES, FI, FR, GB, GR, HR, HU, IE, IS, IT, LT, LU, LV, MC, MK, MT, NL, NO, PL, PT, RO, RS, SE, SI, SK, SM, TR), OAPI (BF, BJ, CF, CG, CI, CM, GA, GN, GQ, GW, ML, MR, NE, SN, TD, TG).

Declarations under Rule 4.17:

— as to the applicant's entitlement to claim the priority of the earlier application (Rule 4.17(iii))

Published:

— with international search report (Art. 21(3))



WO 2012/165936 A1

(54) Title: AN ELECTRICAL INTERCONNECT ASSEMBLY

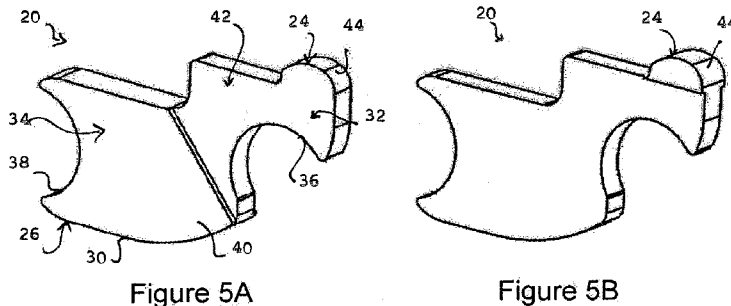

(57) Abstract: An electrical test contact (20) is disclosed for electrically connecting a test terminal (12) of an IC test assembly (14) with an IC terminal (15) of an IC device (16) in an electrical interconnect assembly (10). The test contact (20) is formed of electrically conductive material and comprises a head portion (42) and a foot portion (40). The head portion (42) comprises a first electrical contacting portion (24) for electrically engaging an IC terminal (15) of an IC device (16) during use, and the foot portion (40) comprises a second electrical contacting portion (26) for electrically engaging a test terminal (12) of a test assembly (14) during use. The head portion (42) comprises a head receiving portion (36) arranged to receive a first resiliently biasing member (28) to thereby retain the first resiliently biasing member (28) in contact with the test contact (20). The first resiliently biasing member (28) is arranged to bias the first electrical contacting portion (24) against the IC terminal (15) of the IC device (16) during use. An electrical interconnect assembly (10) comprising a plurality of such test contacts (20) is also disclosed.

AN ELECTRICAL INTERCONNECT ASSEMBLYField of the Invention

5 The present invention relates to an electrical interconnect assembly for use in testing integrated circuit (IC) devices and to a test contact for use in an electrical interconnect assembly.

10 Background of the Invention

As part of an IC manufacturing process, it is important to test manufactured IC devices in order to ensure that the devices are operating correctly and to required
15 specifications. Such testing is generally carried out using an IC test system, the test system having a test assembly and an interconnect assembly arranged to electrically connect the test assembly with pads/leads of an IC during testing so that characteristics of the IC
20 device in response to input electrical stimuli can be determined and compared with reference responses by the test assembly. The interconnect assembly comprises a series of test contacts which extend between respective test terminals of the test assembly and IC terminals of
25 the IC device. The test assembly is arranged to provide an interface between a test assembly and an IC device whilst minimizing the likelihood of damage to leads/pads of the IC device.

30 In one arrangement, the interconnect assembly includes first and second arm portions arranged to respectively connect with test terminals and IC terminals. The test contacts are moveably disposed in the interconnect assembly and resiliently biased such that during use, when
35 an IC device is engaged with the test assembly, a biasing force is exerted so as to urge the first arm portion into good electrical contact with an IC terminal of an IC

device and so as to urge the second arm portion into good electrical contact with a test terminal of the test assembly. The test contacts in this arrangement, however, can transfer excessive force to the test terminal
5 resulting in premature wear of the test terminal and can damage the IC terminal during use.

Summary of the Invention

10 In accordance with a first aspect of the present invention, there is provided an electrical test contact for electrically connecting a test terminal of an IC test assembly with an IC terminal of an IC device in an electrical interconnect assembly, the test contact being
15 formed of electrically conductive material and comprising:
a head portion; and
a foot portion;
the head portion comprising a first electrical contacting portion for electrically engaging an IC
20 terminal of an IC device during use, and the foot portion comprising a second electrical contacting portion for electrically engaging a test terminal of a test assembly during use, the first and second electrical contacting portions being substantially oppositely located on the
25 test contact; wherein
the head portion comprises a head receiving portion arranged to receive a first resiliently biasing member to thereby retain the first resiliently biasing member in contact with the test contact; and wherein
30 the first resiliently biasing member is arranged to bias the first electrical contacting portion against the IC terminal of the IC device during use.

In one embodiment, the head receiving portion restricts
35 the test contact from moving laterally relative to a vertical plane intersecting the test terminal. In another embodiment, the head receiving portion restricts the test

contact from moving vertically relative to the vertical plane intersecting the test terminal. That is, the retention of the first resiliently biasing member reduces vibration and enhances stability, rigidity and co-planarity of the test contact, in particular, during use.

In one embodiment, the first resiliently biasing member (e.g. top elastomer) is located vertically under the first electrical contacting portion (e.g. direct contact area) to absorb the force exerted on the test contact (e.g. test pin) during use. The top elastomer may also be pre-tensioned and is held in place by the head receiving portion of the test pin so that during use the pin only moves vertically downward relative to a vertical plane intersecting the test pin. Thus, by holding the pin in this manner, the test assembly avoids vibration generated during use and only provides a small indent mark on the test terminal rather than a long scratching mark or wiping. This motion also reduces pre-mature wearing of the IC terminals (e.g. contact pins) and improves their lifespan and test yield.

In one embodiment, the head receiving portion exerts a clamping force on the first resiliently biasing member to retain the test contact to the first resiliently biasing member. The head receiving portion may be at least partially circular. In an example of the test contact in use, the test contact retains the first resiliently biasing member to provide better alignment of the test contact with the corresponding IC terminal of an IC device being tested. The test contact thus minimizes its lateral movement during use and minimizes wear of the corresponding IC terminal (e.g. by scratching).

In one embodiment, the foot portion comprises a foot receiving portion arranged to receive a second resiliently biasing member. The foot receiving portion may also be at

least partially circular. In the embodiment, the second resiliently biasing member biases the second electrical contacting portion against the test terminal of the test assembly during use. Also, the second resiliently biasing member decelerates force exerted on the test terminal of the test assembly by the second electrical contacting portion during use.

In one embodiment, the second electrical contacting portion comprises a profile for rotably engaging the test terminal of the test assembly during use.

With this embodiment, the profile comprises a curved surface arranged such that during use rotation of the test contact effects regulation of the contact pressure between the test contact and the test terminal. Also, in an arrangement, the curved surface effects rotational movement of the test contact during use (e.g. a see-saw movement). In an example, the test contact minimizes wear from, for example, indenting the test terminals and the supporting load-board when used. Thus, in use, force is applied on the test contact which is distributed to the first resiliently biasing member acting as a vibration dampener and force dissipater. The test contact is moved down vertically so that its second electrical contacting portion (e.g. load-board contact radius) acts as a fulcrum (e.g. contact surface pivot point) which distributes force to the second resiliently biasing member (e.g. rear elastomer). In an arrangement, the rear elastomer is also pre-tensioned and the foot receiving portion retains the rear elastomer to the test contact to minimize vibration. In this case, the second biasing member also acts as counter force generator and a force dissipater to protect the load-board against wear or damage whilst maintaining contact with the load-board. Also, the profile of the test contact enables, after force is applied to the top of the test contact, the contact surface to contact the load-board without excessive pressure by diverting away some of

the force with a sliding action/motion towards the second resiliently biasing member.

5 The test contact may be formed of metal material, such as precious metal material, and in one arrangement, the metal material comprises NiPdAu plating. It will be appreciated by those persons skilled in the art that the material may comprise NiPd plating, Au plating, or another plating material possessing desirable properties, such as
10 desirable hardness and durability. It will also be appreciated that the hard plating (e.g. NiPd/NiPdAu) can cause test contacts to wear prematurely under high force and vibration.

15 In one embodiment, the first and/or the second electrical contacting portions is/are arranged to facilitate sliding of the first and/or the second electrical contacting portion relative to the respective IC terminal or test terminal. The first and/or the second electrical
20 contacting portion may comprise beryllium copper material. In one arrangement, the first electrical contacting portion comprises a profile arranged to facilitate sliding of the first electrical contacting relative to the IC terminal.

25 In one embodiment, the foot portion comprises a thickness greater than a thickness of the head portion. With this embodiment, the thickness of the head portion may be less than the width of an IC terminal of an IC device desired
30 to be tested. In an alternative embodiment, the head portion comprises a thickness greater than a thickness of the foot portion.

In one embodiment, the first resiliently biasing member
35 comprises an elastomeric member. Also, the second resiliently biasing member may comprise an elastomeric member.

In accordance with a first aspect of the present invention, there is provided an electrical interconnect assembly for electrically connecting test terminals of an IC test assembly with respective IC terminals of an IC device, the electrical interconnect assembly comprising:

5 a first resiliently biasing member;

a plurality of test contacts as claimed in any one of the preceding claims, each of the test contacts being retained in contact with the first resiliently biasing

10 member; and

a housing provided with a plurality of contact sockets, each contact socket being arranged to receive a test contact such that the test contact is movable during use relative to the contact socket; wherein

15 the first resiliently biasing member arranged to bias the respective first electrical contacting portions against the IC terminals of the IC device during use.

In one embodiment, the first and second resiliently

20 biasing members comprise respective elongate elastomeric members, which may be substantially cylindrical. While the elastomeric members are generally cylindrical in this embodiment, it will be understood that any suitable shape is envisaged.

25 In an embodiment, the second resiliently biasing member prevents the test contacts from contacting the housing, in particular the corresponding contact sockets, with excessive force. Thus, in the embodiment, the second

30 resiliently biasing member provides safety for the sockets and prevents the test contacts from over travelling their home position in their respective sockets by acting like a vertical spring loaded pin. The second biasing member

also decelerates force applied to the test contacts,

35 during testing, and pushes the test contacts back to their home position without excessive stress on the load-board to prolong load-board life and to improve test yield.

In one embodiment, each contact socket is configured such that the contact socket is keyed to the foot portion so that the amount of permitted rotation of the test contact relative to the respective contact socket is restricted.

5 In this embodiment, the contact socket may also comprise a stop to restrict rotation of the test contact. Each contact socket and stop further improves co-planarity of the test contacts to minimize wear of the IC terminals.

10 Brief Description of the Drawings

The present invention will now be described, by way of example only, with reference to the accompanying drawings, in which:

15

Figure 1 is a diagrammatic cross-sectional view of a test system of the type including a test assembly and an electrical interconnect assembly in accordance with an embodiment of the present invention, and showing a test
20 contact forming part of the interconnect assembly;

Figure 2 is a diagrammatic cross-sectional view of a test contact forming part of the interconnect assembly of Figure 1;

25

Figure 3 is a further diagrammatic cross-sectional view of the test contact of Figure 2;

Figure 4 is a further diagrammatic cross-sectional
30 view of the test contact of Figure 2;

Figure 5A is a diagrammatic perspective view of the test contact of Figure 2;

35 Figure 5B is a diagrammatic perspective view of a test contact according to another embodiment;

Figure 6 is diagrammatic cross-sectional view of a test system, and showing an IC device disposed on the interconnect assembly of Figure 1;

5 Figure 7 is diagrammatic cross-sectional view of a test system, and showing an IC device disposed on the interconnect assembly of Figure 1 in use;

Figure 8 is a further diagrammatic cross-sectional
10 view of the the interconnect assembly of Figure 1; and

Figure 9 is a diagrammatic perspective view of an interconnect assembly in accordance with an embodiment of the invention, and showing a plurality of test contacts of
15 the type shown in Figure 2.

Description of an Embodiment of the Invention

Referring to Figure 1, a test system 8 is shown for
20 testing IC devices. The test system 8 is of a type including an electrical interconnect assembly 10 according to an embodiment of the present invention for forming an electrical connection between test terminals 12 of a test assembly 14 and IC terminals 15 of an IC device 16 desired
25 to be tested. The test terminals 12 are located on a load-board of the test assembly 14.

The test assembly 14 is arranged to carry out a series of tests on an IC device 16 connected to the test assembly 14
30 through the interconnect assembly 10, for example by applying defined signals to the test terminals 12, monitoring response signals and comparing the response signals to reference responses.

35 The interconnect assembly 10 comprises a housing 18 having a plurality of test contacts 20, as shown in Figure 4, movably disposed in respective contact sockets 22 formed

in the housing 18. Each of the test contacts 20 in this example is formed of electrically conductive material, for example a NiPdAu plated material, and is formed of generally planar sheet-like material.

5

In the embodiment, each test contact 20 is generally L-shaped and includes a first electrical contacting portion 24 arranged to engage during use with an IC terminal 15 and a second electrical contacting portion 26 arranged to
10 engage during use with a test terminal 12. The test contacts are arranged to engage with a first resiliently biasing member 28, in this example in the form of an elongate generally cylindrical elastomeric member, which cooperates with the test contacts 20 to urge the first
15 electrical contacting portion 24 towards an IC terminal 15, and to urge the second electrical contacting portion 26 towards a test terminal 12. The test contacts 20 are prevented from lateral and vertical movement relative to a vertical plane intersecting the test contacts 20 by
20 retaining in contact with the first biasing member 28 with respective suitably shaped receiving portions. It can be seen in the Figures that the first biasing member 28 is mounted to the housing 18.

25 In addition, it will be understood that the retention by the receiving portions reduces skewing of the test contacts 20 and thereby provides better co-planarity of test contacts 20. That is, the retention prevents the contacts 20 from moving vertically and laterally relative
30 to a vertical plane intersecting the test terminals 15 to maintain alignment with the IC terminals 15 of an IC device 16 to be tested.

It can be seen from the Figures that test contacts 20 each
35 comprise a head portion 32 and a foot portion 34, and the head portion comprises a head receiving portion 36 which is suitably shaped to exert a clamping force on the

cylindrical first resiliently biasing member 28 so that the head receiving portions 36 is retained in contact with the first resiliently biasing member 28. In particular, the receiving portion 36 is shown as being partially
5 circular to receive the first resilient means 28. That is, the receiving portion 36 exerts a pre-tension force on the first resilient means 28 so that it can be retained.

During use, an IC device 16 to be tested is disposed on
10 the interconnect assembly 10 and the IC device 16 is urged towards the interconnect assembly 10, as indicated by Arrow A shown in Figure 3, in the direction of the vertical plane intersecting the test terminal. Once in the testing position, the IC device 16 is secured in any
15 appropriate way, for example using one or more screws. This causes establishment of good electrical contact between each first contacting portion 24 and an IC portion 15 and between each second contacting portion 26 and a test terminal 12, with each test contact 20 moving from a
20 first position shown by line 27 in Figure 3 in the direction of Arrow A to a second position shown by line 25 in Figure 3. As the test contact 20 moves between the first position and the second position, a small degree of rotation occurs which causes a wiping action to occur at
25 the IC terminals 15 and at the test terminals 12, thereby ensuring good electrical contact.

A test contact 20 in accordance with an embodiment of the present invention is shown in Figure 5A. The test contact
30 20 comprises a head portion 32, a foot portion 34 and a receiving portion 36, as described, with the receiving portion 36 in this embodiment of generally part-circular shape. The receiving portion 36 is configured to receive the first biasing member 28 such that during use when an
35 IC device 16 being tested is engaged with the interconnect assembly 10 and the test contact 20 moves from the first position to the second position, the biasing member 28 is

compressed and the biasing member 28 thereby exerts a biasing force on the IC terminals 15 and the test terminal 12.

5 That is, during use, the IC device 16 is urged towards the interconnect assembly 10, as indicated by Arrow A of Figure 3, and the test contact 20 is rotated to the second position shown by the line 25 in Figure 3. The head portion 32 thus compresses the first biasing member 28
10 from a first position 35 shown in Figure 2 to a second position 37 shown in Figure 3 and biases the test contact 20 back towards the first position. Also, the act of rotation of the test contact 20 urges the foot portion 38 towards a second resiliently biasing member 29 which
15 dampens the rotation and biases the second electrical contacting portion 26 against the test terminal 12 of the test assembly 10. Under rotation, the second resiliently biasing member 29 compresses from a first position 31 shown in Figure 1 to a second position 33 shown in Figure
20 3 to dampen the rotation and ensure that good electrical connection is made between the second electrical contacting portion 26 and the test terminal 12 but not so excessive so as to be detrimental to the test terminal 12. That is, the second resiliently biasing member 29
25 decelerates force exerted on the test terminal 12 by the second electrical contacting portion 26 during use to minimize wear of the test terminal 12.

It can be seen that the second resiliently biasing member
30 29 is also substantially cylindrical in shape and the foot portion 34 of the test contact 20 comprises a foot receiving portion 38 arranged to receive the second resiliently biasing member 29. The foot receiving portion 38 is also part circular and, in one example, may also be
35 arranged to exert a clamping force on the second resiliently biasing member 29, provided that the test contact 20 can still rotate and the second electrical

- 12 -

contacting portion 26 can rotably engage the test terminal 12. The first 28 and second biasing members 29 are also fixed to the housing 18 and retained in contact with the test contact 20 by the respective clamping forces imparted
5 by the head receiving portion 36 and the foot receiving portion 38 of the test contact 20.

In addition, the test contact 20 also includes a profile for rotably engaging the test terminal 12. The profile comprises a curved contact surface 30, part of which
10 constitutes the second electrical contacting portion 26, such that during use the curved contact surface 30 regulates the contact pressure on the test terminal 12 to maintain a good electrical connect but minimize wear. In
addition, the curved surface 30 enables the test contact
15 20 to regulate the contact pressure at the second electrical contacting portion 26 by self-adjusting its orientation relative to the test terminal 12.

Figure 4 shows the forces applied to the test contact 20
20 during use of the test system 8. During use, the IC device 16 is urged towards the interconnect assembly 10, as indicated by Arrows A, which imparts a force to the test contact 20 and, in turn, to the first biasing member 28 as shown by Arrow B. The first biasing member 28 acts
25 as a dampener and provides a counter force, shown by dotted arrow C, to the test contact 20. The test contact 20 is moved down vertically with the curved contact surface 30 acting as a fulcrum to translate force to the second resiliently biasing member 29 as shown by Arrow D.
30 The second biasing member 29 also provides a counter force, shown by dotted Arrow E, to protect the load-board from wear.

The biasing force exerted by the first electrical
35 contacting portion 24 on an IC terminal 15 should also be sufficient to achieve good electrical contact, but not so excessive so as to be potentially detrimental to the IC

terminal 15. Furthermore, in order to facilitate good sliding action with some resilience at the IC terminals 15, at least part of the test contact 20 at the first electrical contacting portion 24 may be formed of beryllium copper material. In addition, it can be seen in Figure 5A that the first electrical contacting portion 24 comprises a radius 44 suitable for sliding against the IC terminal 15 so that the test contact 20 can be rotated into the second position.

10

The test contact 20 shown in Figure 5A comprises a body portion 40 of generally constant thickness and the head portion 32 has a protruding portion 42 of generally reduced thickness relative to the body portion 40. That is, the protruding portion 42 is reduced in thickness symmetrically towards the radius 44, which is suitable for sliding against the IC terminal 15, to provide sufficient contact force with the IC terminal 15 and the test terminal 12 of the load-board whilst maintaining balance of the test contact 20 under use. The symmetry of the test contact 20 enables its centre of gravity to be balanced and thus increases the lifespan of the test assembly 14. Also, the reduced thickness enables the test contact 20 to be used with finer pitch IC devices whilst maintaining sufficient thickness of the test contact 20 to engage a stop 50 of the housing 18. It will be appreciated by those persons skilled in the art that the contact socket 22 formed in the housing 18 is configured to receive the reducing thickness test contact 20, for example with suitable thickness socket walls, to enhance durability of the electrical interconnect assembly 10.

The protruding portion 42 also includes a surface which constitutes the first electrical contacting portion 24. The test contact 20 shown in Figure 5A is particularly suitable for use with pad/unleaded type IC devices. Pad/unleaded type IC devices require a higher contact

- 14 -

force at the pad - test contact interface than leaded type IC devices and, as such, damage to the IC terminals 15 and/or the test terminals 12 is more likely.

5 Alternatively, the test contact 20 may comprise a body portion 40 of generally constant thickness and the protruding portion 42 having generally an enlarged thickness relative to the body portion 40, which is more suited to leaded type IC devices. In a further
10 alternative, just the radius 44 of the protruding portion 42 has a greater thickness relative to the body portion 40 to form a headed pin, as shown in Figure 5B. In this case, the enlarged radius 44 of the protruding portion 42 is also symmetrical to ensure balance of the test contact
15 20 under use. The reduced thickness of the body portion 40 relative to the headed pin also allows for finer pitched IC devices to be tested. Also, it will be understood that by maintaining a relatively large width at the second electrical contacting portion 26, the contact
20 pressure at the test contact - test terminal interface is maintained sufficiently low to avoid damage to the test terminals 12.

It can also be seen in Figures 6 and 7 that the contact
25 socket 22 comprises a stop 50 to restrict rotation of the test contact 20. The stop 50 acts on the test contact 20 to restrict vertical movement of the test contact 20 relative to the vertical plane intersecting the test terminal 16, as well as frictionally restricting lateral
30 movement, thereby further maintaining the co-planarity of the test contact 20. That is, during use of the test system 8, the IC device 16 is urged from a first position shown in Figure 6 towards the interconnect assembly 10 to a second position shown in Figure 7 which acts to rotate
35 the test contact 20 within the socket 22 to form an electrical connection between the test terminals 12 and the IC terminals 15 of the IC device 16. This can be seen

more clearly in Figure 8 where the IC device 16 is moved in the direction of Arrow A.

Figure 9 shows a test system 46 according to an embodiment
5 of the present invention showing a plurality of the above described test contacts 20 in their respective contact sockets 22. In this system 46, each test contact 20 is configured in their respective contact socket 22 and each
10 contact socket 22 is keyed to the corresponding foot portion 34 so that the amount of permitted rotation of each test contact 20 relative to the respective contact socket 22 is restricted. Furthermore, the arrangement of the contact socket 22 allows for air flow (shown by arrows 48 in Figure 1) to cool the IC device 16 and the
15 electrical interconnect assembly 10 during use.

Modifications and variations as would be apparent to a skilled addressee are deemed to be within the scope of the present invention.

Claims:

1. An electrical test contact for electrically connecting a test terminal of an IC test assembly with an IC terminal of an IC device in an electrical interconnect assembly, the test contact being formed of electrically conductive material and comprising:
- a head portion; and
 - a foot portion;
- the head portion comprising a first electrical contacting portion for electrically engaging an IC terminal of an IC device during use, and the foot portion comprising a second electrical contacting portion for electrically engaging a test terminal of a test assembly during use, the first and second electrical contacting portions being substantially oppositely located on the test contact; wherein
- the head portion comprises a head receiving portion arranged to receive a first resiliently biasing member to thereby retain the first resiliently biasing member in contact with the test contact; and wherein
 - the first resiliently biasing member is arranged to bias the first electrical contacting portion against the IC terminal of the IC device during use.
2. An electrical test contact as claimed in claim 1, wherein the head receiving portion restricts the test contact from moving laterally relative to a vertical plane intersecting the test terminal.
3. An electrical test contact as claimed in claim 1 or 2, wherein the head receiving portion restricts the test contact from moving vertically relative to a vertical plane intersecting the test terminal.
4. An electrical test contact as claimed in any one of claims 1 to 3, wherein the head receiving portion exerts a

clamping force on the first resiliently biasing member to retain the test contact to the first resiliently biasing member.

- 5 5. An electrical test contact as claimed in claim 4, wherein the head receiving portion is at least partially circular.
- 10 6. An electrical test contact as claimed in any one of claims 1 to 5, wherein the foot portion comprises a foot receiving portion arranged to receive a second resiliently biasing member.
- 15 7. An electrical test contact as claimed in claim 6, wherein the foot receiving portion is at least partially circular.
- 20 8. An electrical test contact as claimed in claim 6 or 7, wherein the second resiliently biasing member biases the second electrical contacting portion against the test terminal of the test assembly during use.
- 25 9. An electrical test contact as claimed in claim 8, wherein the second resiliently biasing member decelerates force exerted on the test terminal of the test assembly by the second electrical contacting portion during use.
- 30 10. An electrical test contact as claimed in any one of claims 1 to 9, wherein the second electrical contacting portion comprises a profile for rotably engaging the test terminal of the test assembly during use.
- 35 11. An electrical test contact as claimed in claim 10, wherein the profile comprises a curved surface arranged such that during use rotation of the test contact effects regulation of the contact pressure between the test contact and the test terminal.

12. An electrical test contact as claimed in claim 11, wherein the curved surface effects rotational movement of the test contact during use.

5

13. An electrical test contact as claimed in any one of the preceding claims, wherein the test contact is formed of metal material.

10 14. An electrical test contact as claimed in claim 13, wherein the test contact is formed of precious metal material.

15 15. An electrical test contact as claimed in claim 13, wherein the metal material comprises NiPdAu plating.

16. An electrical test contact as claimed in any one of the preceding claims, wherein at least one of the first and the second electrical contacting portions is arranged
20 to facilitate sliding of at least one of the first and second electrical contacting portion relative to the respective IC terminal or test terminal.

17. An electrical test contact as claimed in any one of
25 the preceding claims, wherein the foot portion comprises a thickness greater than a thickness of the head portion.

18. An electrical test contact as claimed in any one of
30 the preceding claims, wherein the first resiliently biasing member comprises an elastomeric member.

19. An electrical test contact as claimed in any one of
claims 6 to 18, wherein the second resiliently biasing member comprises an elastomeric member.

35

20. An electrical interconnect assembly for electrically connecting test terminals of an IC test assembly with

- 19 -

respective IC terminals of an IC device, the electrical interconnect assembly comprising:

a first resiliently biasing member;

a plurality of test contacts as claimed in any one of
5 the preceding claims, each of the test contacts being retained in contact with the first resiliently biasing member; and

a housing provided with a plurality of contact sockets, each contact socket being arranged to receive a
10 test contact such that the test contact is movable during use relative to the contact socket; wherein

the first resiliently biasing member arranged to bias the respective first electrical contacting portions against the IC terminals of the IC device during use.

15

21. An electrical interconnect assembly as claimed in claim 20 wherein each contact socket is configured such that the contact socket is keyed to the foot portion so that the amount of permitted rotation of the test contact
20 relative to the respective contact socket is restricted.

22. An electrical interconnect assembly as claimed in claim 21, wherein the contact socket comprises a stop to restrict rotation of the test contact.

25

1/4

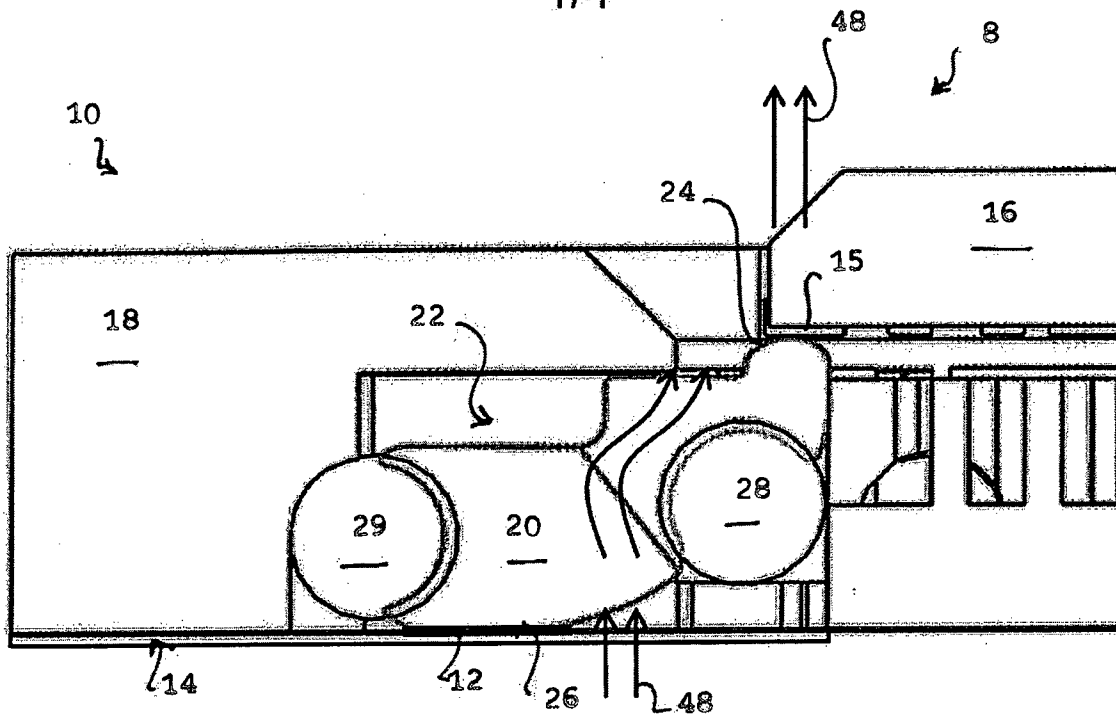

Figure 1

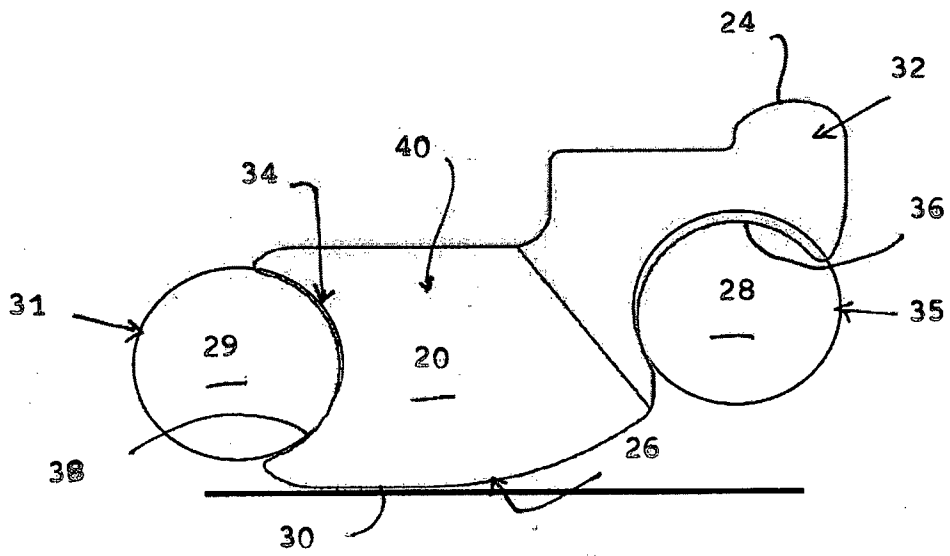

Figure 2

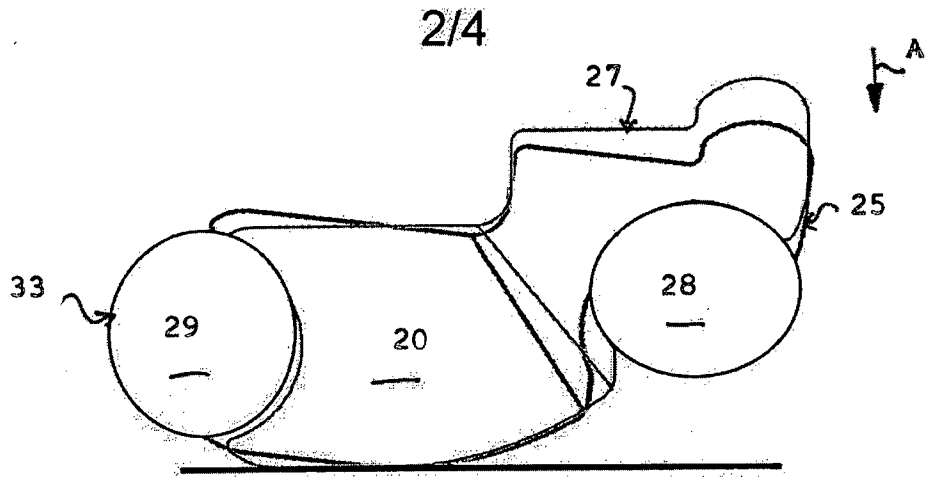

Figure 3

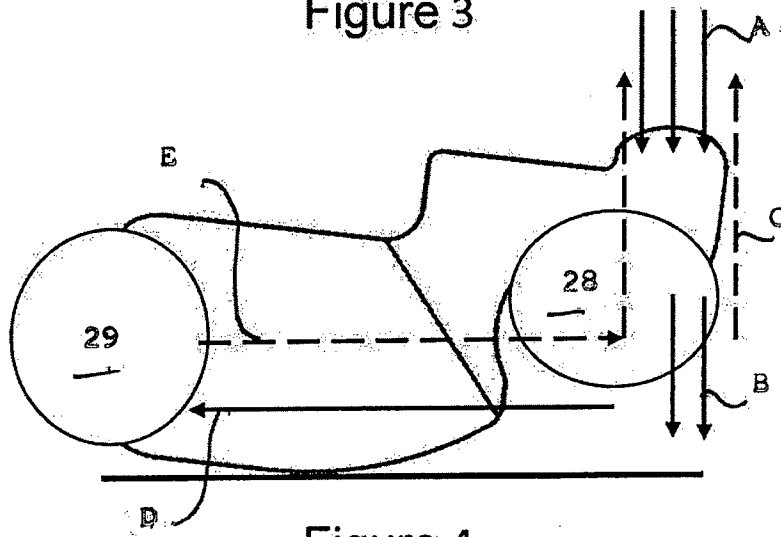

Figure 4

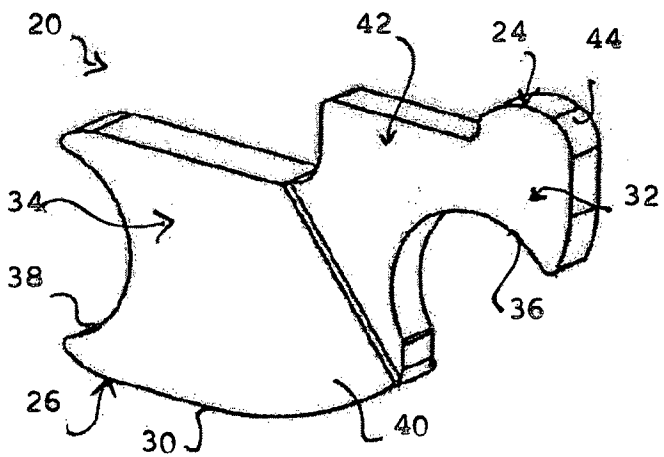

Figure 5A

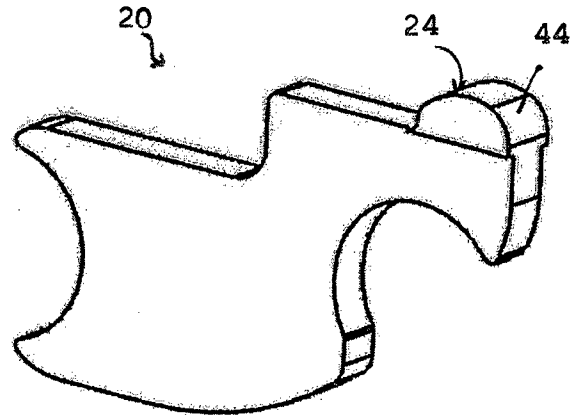

Figure 5B

3/4

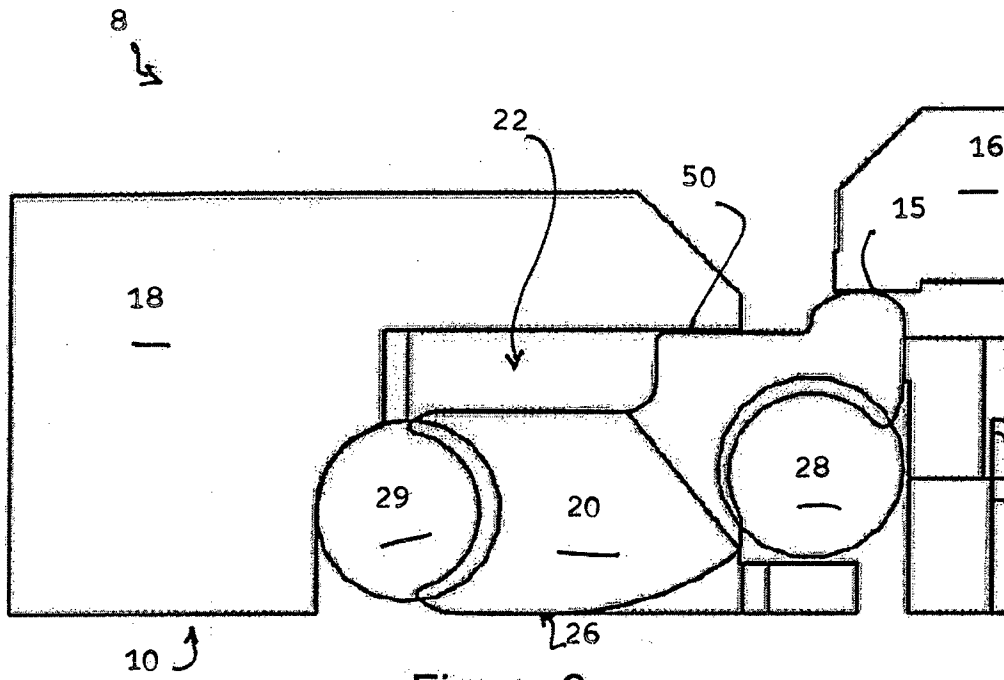

Figure 6

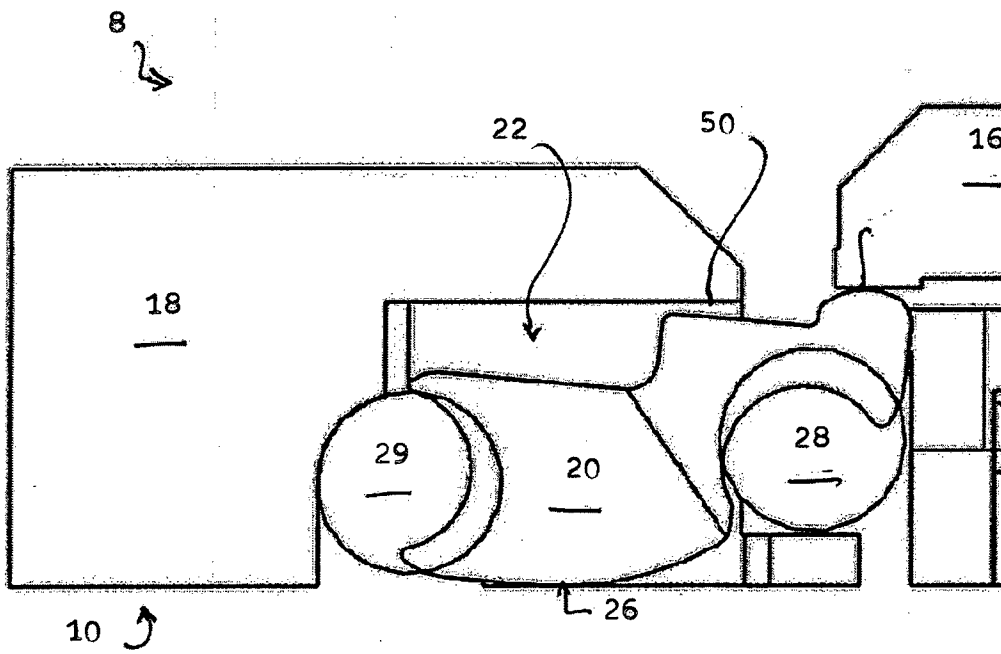

Figure 7

4/4

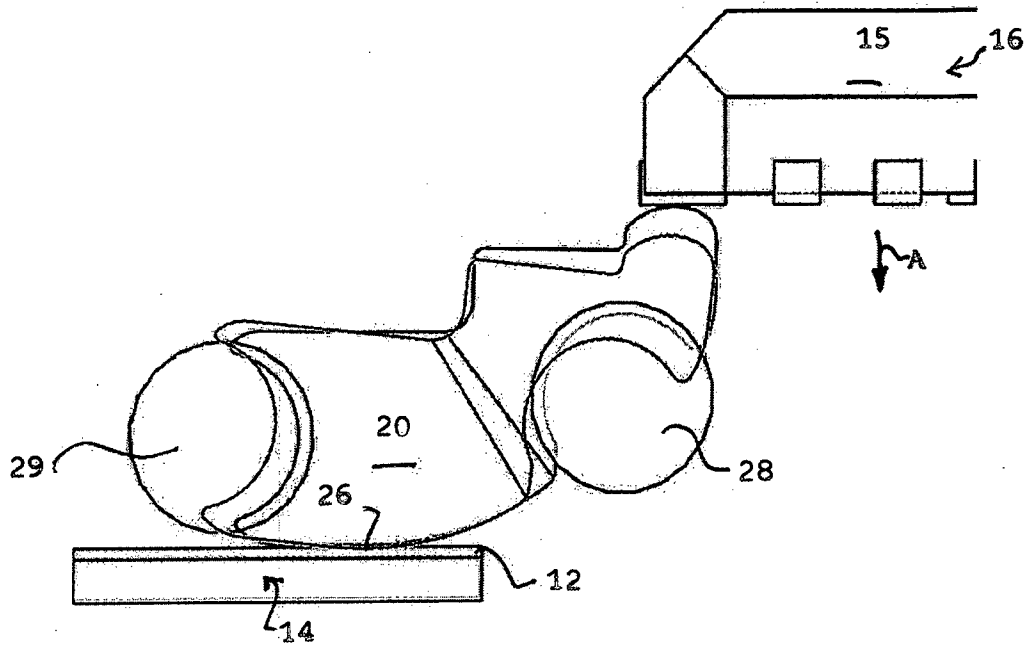

Figure 8

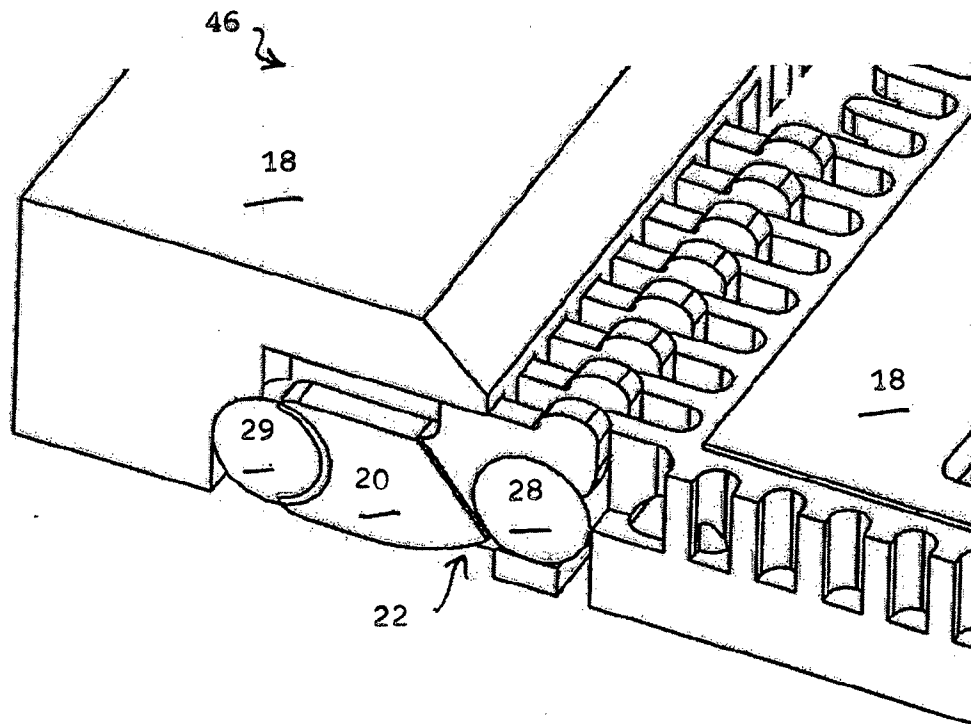

Figure 9

INTERNATIONAL SEARCH REPORT

International application No
PCT/MY2011/000058

A. CLASSIFICATION OF SUBJECT MATTER
INV. G01R1/04
ADD.

According to International Patent Classification (IPC) or to both national classification and IPC

B. FIELDS SEARCHED

Minimum documentation searched (classification system followed by classification symbols)
G01R

Documentation searched other than minimum documentation to the extent that such documents are included in the fields searched

Electronic data base consulted during the international search (name of data base and, where practical, search terms used)
EPO-Internal, WPI Data, INSPEC

Category*	Citation of document, with indication, where appropriate, of the relevant passages	Relevant to claim No.
X	US 2008/054924 A1 (FOONG WEI KUONG [MY]) 6 March 2008 (2008-03-06) abstract; claims 1-11; figures 1-3 paragraph [0008] - paragraph [0013] paragraph [0019] - paragraph [0023] -----	1-22
X	EP 1 826 575 A2 (SHELL DENNIS B [US]; GILK MATHEW L [US]; LOPEZ JOSE E [US] JOHNSTECH I) 29 August 2007 (2007-08-29) abstract; claims 1-8; figures 1-3 paragraph [0007] - paragraph [0010] paragraph [0013] - paragraph [0024] -----	1-22
X	EP 1 753 100 A1 (NIHON MICRONICS KK [JP]) 14 February 2007 (2007-02-14) abstract; claims 1-11; figures 1-13 paragraph [0015] - paragraph [0031] paragraph [0082] - paragraph [0093] -----	1-22
	-/--	

Further documents are listed in the continuation of Box C.

See patent family annex.

* Special categories of cited documents :

<p>"A" document defining the general state of the art which is not considered to be of particular relevance</p> <p>"E" earlier document but published on or after the international filing date</p> <p>"L" document which may throw doubts on priority claim(s) or which is cited to establish the publication date of another citation or other special reason (as specified)</p> <p>"O" document referring to an oral disclosure, use, exhibition or other means</p> <p>"P" document published prior to the international filing date but later than the priority date claimed</p>	<p>"T" later document published after the international filing date or priority date and not in conflict with the application but cited to understand the principle or theory underlying the invention</p> <p>"X" document of particular relevance; the claimed invention cannot be considered novel or cannot be considered to involve an inventive step when the document is taken alone</p> <p>"Y" document of particular relevance; the claimed invention cannot be considered to involve an inventive step when the document is combined with one or more other such documents, such combination being obvious to a person skilled in the art.</p> <p>"&" document member of the same patent family</p>
--	--

Date of the actual completion of the international search 23 February 2012	Date of mailing of the international search report 02/03/2012
---	--

Name and mailing address of the ISA/ European Patent Office, P.B. 5818 Patentlaan 2 NL - 2280 HV Rijswijk Tel. (+31-70) 340-2040, Fax: (+31-70) 340-3016	Authorized officer Nadal, Rafael
--	---

INTERNATIONAL SEARCH REPORT

International application No
PCT/MY2011/000058

C(Continuation). DOCUMENTS CONSIDERED TO BE RELEVANT		
Category*	Citation of document, with indication, where appropriate, of the relevant passages	Relevant to claim No.
X	US 2007/272924 A1 (YUNG-SING CHU [TW]) 29 November 2007 (2007-11-29) abstract; claims 1-5; figure 1 paragraph [0004] - paragraph [0005] -----	1-22
X	US 2009/267629 A1 (FOONG WEI KUONG [MY]) 29 October 2009 (2009-10-29)	1-5
A	abstract; claims 1-11; figures 1-3 paragraph [0007] - paragraph [0018] paragraph [0024] - paragraph [0028] -----	6-22

INTERNATIONAL SEARCH REPORT

Information on patent family members

International application No PCT/MY2011/000058

Patent document cited in search report	Publication date	Patent family member(s)	Publication date
US 2008054924	A1	CN 101140295 A	12-03-2008
		US 2008054924 A1	06-03-2008
EP 1826575	A2	CA 2579697 A1	24-08-2007
		EP 1826575 A2	29-08-2007
		JP 2007248460 A	27-09-2007
		KR 20070088404 A	29-08-2007
		SG 135138 A1	28-09-2007
		US 2007236236 A1	11-10-2007
EP 1753100	A1	EP 1753100 A1	14-02-2007
		JP 4395165 B2	06-01-2010
		TW I246600 B	01-01-2006
		US 2007072449 A1	29-03-2007
		WO 2005119856 A1	15-12-2005
US 2007272924	A1	TW M302022 U	01-12-2006
		US 2007272924 A1	29-11-2007
US 2009267629	A1	NONE	