

No. 694,331.

Patented Feb. 2

F. SNYDER.

BREECH LOADING FIREARM.

(Application filed Nov. 21, 1900.)

BEST AVAILABLE COPY

(No Model.)

2 Shee

Fig. 1.

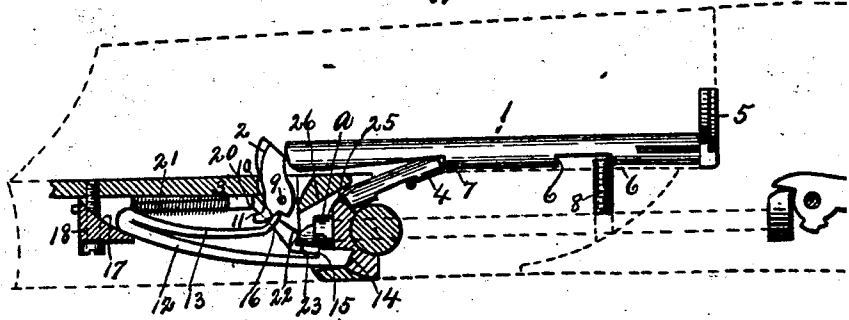

Fig. 2.

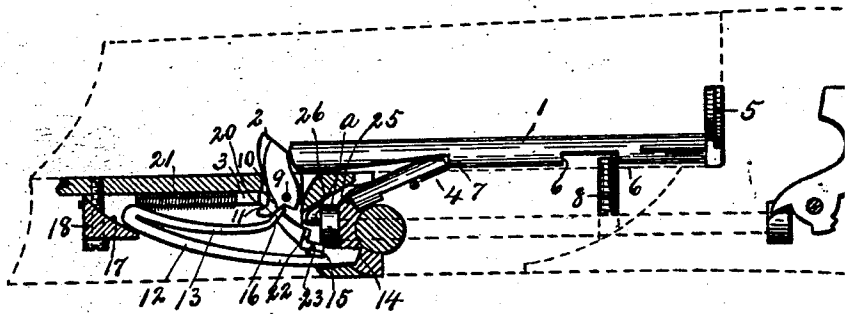
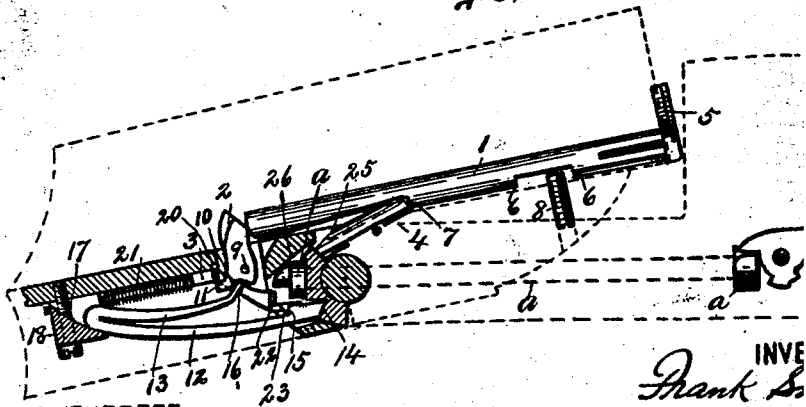

Fig. 3.



WITNESSES.

H. Arthur,

H. C. Chase

INVE
Frank S.

BY
Smith & D.
ATTORNEY

No. 694,331.

Patented Feb. 2

F. SNYDER.
BREECH LOADING FIREARM.

(Application filed Nov. 21, 1900.)

(No Model.)

2 Sheets

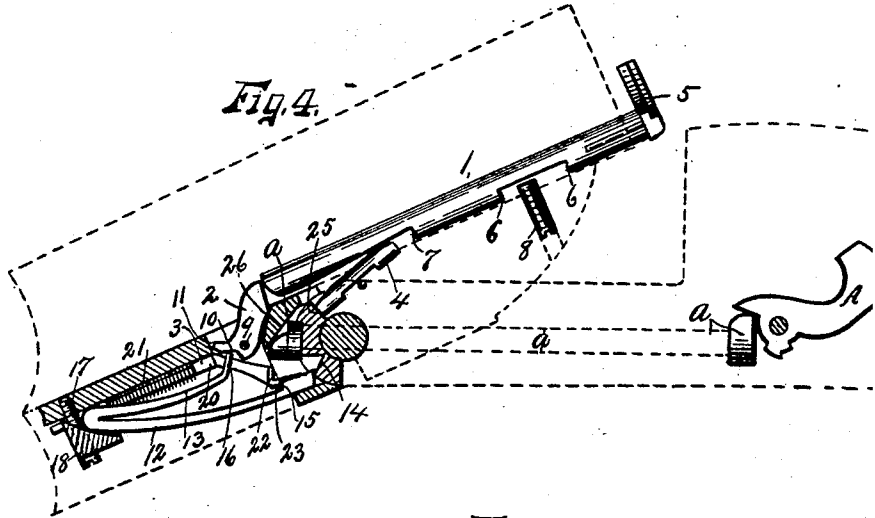

Fig. 5,

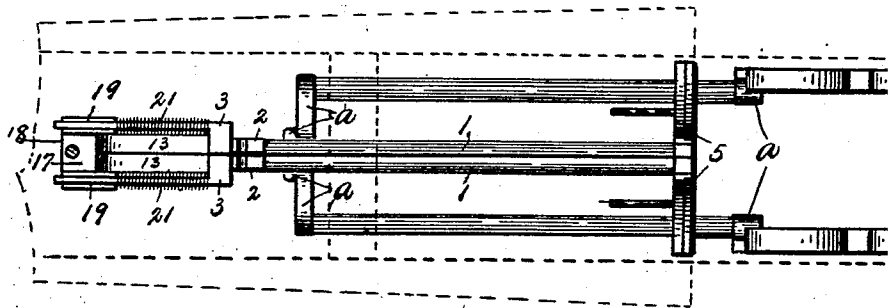

Fig. 6,

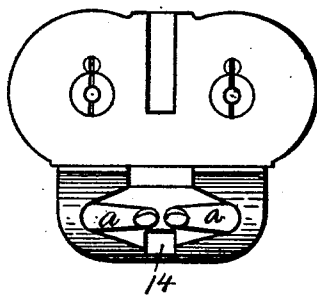

Fig. 7,

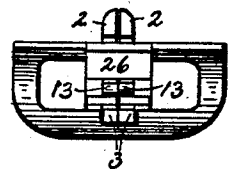

Fig. 9,

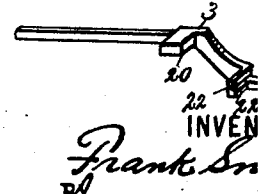

Fig. 8,



WITNESSES.

J. C. Arthur,

W. C. Chase

Frank S. Snyder
ATTORNEY

UNITED STATES PATENT OFFICE.

FRANK SNYDER, OF FULTON, NEW YORK, ASSIGNOR TO HUNTER ARMS COMPANY, OF FULTON, NEW YORK, A CORPORATION OF NEW YORK.

BREECH-LOADING FIREARM.

SPECIFICATION forming part of Letters Patent No. 694,881, dated February 25, 1902.

Application filed November 21, 1900. Serial No. 37,221. (No model.)

To all whom it may concern:

Be it known that I, FRANK SNYDER, of Fulton, in the county of Oswego, in the State of New York, have invented new and useful improvements in Breech-Loading Firearms, of which the following, taken in connection with the accompanying drawings, is a full, clear, and exact description.

This invention relates to improvements in breech-loading firearms, and particularly to the ejector mechanism for extracting the cartridges.

The object of my invention is to produce a simple and practical mechanism removably supported on the barrels of the gun and adapted to operate an extractor-bar for forcibly ejecting the cartridges from the barrel when the gun is broken and only after the cartridge has been fired or discharged.

The further object of my invention is to provide means for starting the cartridge and moving the same a limited distance independently of the former mechanism when the gun is broken, whereupon a loaded cartridge may be withdrawn by hand, if desired.

To this end the invention consists in the combination, construction, and arrangement of the component parts of an ejector mechanism, as hereinafter fully described, and pointed out in the claims.

Figures 1, 2, 3, and 4 are similar elevations, partly in section, of my improved ejector mechanism, illustrating the successive operations of said mechanism for discharging the cartridge and extracting the same from the barrel. Fig. 5 is a top plan view of the detached ejector mechanism as seen in Fig. 1. Fig. 6 is an end view of the gun-stock or frame, showing particularly the ends of the cocking bars or levers. Fig. 7 is a rear end view of the detached fore-end piece and the ejector mechanism mounted thereon. Figs. 8 and 9 are isometric views, respectively, of one of the detached tumblers or kickers and one of the sears for controlling the movement of the said tumbler or kicker.

Similar reference characters indicate corresponding parts in all the views.

As seen in the drawings, my improved ejector mechanism consists, essentially, of an extractor-bar 1, spring-actuated means 2 for op-

erating the extractor-bar, a sear 3 for controlling the operation of the spring-actuated means, and additional means 4 for starting the extractor-bar and moving the same a limited distance.

The extractor-bar 1 may be of any desired form, size, or construction, provided with a flanged head 5, separated stop-shoulders 6, and an abutting face 7. This extractor-bar is reciprocally movable in the barrel-frame, the head 5 being adapted to engage the rim of the cartridge for forcing said cartridge substantially parallel with the bore of the barrel. The stop-shoulders 6 are arranged to engage the opposite faces of a suitable stop 8, removably secured to the barrel-lug, and serves to limit the reciprocal movement of the extractor-bar. The spring-actuated means 2 for forcing the extractor-bar lengthwise of the barrel for forcibly ejecting the cartridge consists of a rock bar or lever pivoted at 9 and having one end adapted to engage the forward end face of the extractor-bar and its other end provided with an inclined face 10 and an engaging shoulder 11. The spring for actuating the rock-arm 2 is substantially V-shaped, consisting of two spring-arms 12 and 13, united at one end, the free end of the arm 12 being arranged to engage the end face 14 of the gun-frame and is provided with an engaging shoulder 15 in proximity to its free extremity for engaging the sear presently described. The free end of the arm 13 is provided with an engaging shoulder 16 for engaging the inclined face 10 of the rock-arm or tumbler 2, being normally engaged with said tumbler at a point in proximity to its pivot 9, and is adapted to ride upon the inclined face 10 during the breaking of the gun for operating the tumbler 2 and forcing the extractor-bar outwardly a limited distance.

The united ends of the spring-arms 12 and 13 are movable in an inclined way 17, provided in a suitable block 18, which is secured to the fore-end piece of the gun in any desired manner. The inclined face 10 of the tumbler 2 usually inclines downwardly from its pivotal point 9, and it is evident that when the gun is broken the rear end of the spring-arm 12, abutting against the shoulder 14 of the gun-frame, thereby forces the spring for-

inclined way 17. The rear during the breaking of the downwardly-inclined face pressing the spring, it being the forward movement of said inclined way 17 also serves to compress the leaves of said ch other. The sear 3 is also fore-end piece, having one suitable way or slot 19, lock 18, and its other end is engaging shoulder 20, nor path of the shoulder 11 of a suitable spring 21 for the movement of said tumbler has been discharged breaking of the gun.

s. 1 and 2, the shoulders 11 ally separated from each other for permitting the tumbler a limited distance before for the purpose of moving the bar a slight distance, and the discharged cartridge

This sear 3 extends beyond and is provided at its rear end shoulders 22 and 23, the shoulder engaged to engage the forward cocking member *a* and the disposed in the path of the spring-arm 12. When the gun is forced to its cocked position in Fig. 1, by the cocking forward end of said cocking member locked with the shoulder 22 and the shoulder 20 of the sear in the path of movement of the shoulder 2.

Shoulders 15 and 23 are normally separated when the gun is closed, shoulders 1 and 2, and are arranged in each other that when the gun is closed shoulders 15 and 23 engage each other at the same time that the shoulder 1 of engagement with the forward cocking-bar, and it is thereat the shoulder 15 serves to hold the bar forwardly and to hold the tumbler 2 when the shoulder 1 is out of engagement with the forward cocking-bar. It is thus apparent that when the hammer is in its cocked position the cartridge has been fired the gun may be broken any time without ejecting the cartridge. This feature of my invention is entirely new, and as is stated, the cartridge may be ejected during the breaking of the gun so that the cartridge cannot be fired from the barrel by the ejector if the same has been fired or

the hammer has been released, as in Fig. 3, the spring 21 forces the tumbler, thereby moving the shoulder

20 into the path of movement of the shoulder 11, and during the breaking of the gun said shoulder 11 engages the shoulder 20, thereby limiting the movement of the tumbler 2 and permitting the spring-arms 12 and 13 to be tensioned toward each other by the inclined face 10 and the way 17. As the barrel continues its downward movement and the end of the spring-arm 13 continues to ride upon the inclined face 10 of the tumbler 2 away from the pivot 9 the shoulder 15 of the spring-arm 12 engages the shoulder 23 of the sear, thereby moving the sear forwardly and forcing the shoulder 20 out of engagement with the shoulder 11 of the tumbler 2, whereupon the spring-arm 13 instantly rocks the tumbler 2, and thereby forces the extractor-bar rearwardly for forcibly ejecting the cartridge from the barrel.

As previously stated, the shoulders 15 and 23 are normally separated from each other and are only adapted to engage with each other when the barrel reaches the limit of its downward movement, thereby compressing the spring as much as possible before the shoulder 20 is released from engagement with the shoulder 11 of the tumbler 2.

By constructing and arranging the parts of my ejecting mechanism as just described I am enabled to remove the loaded cartridge at any time desired, the extractor-bar is prevented from being actuated by the springs before the cartridge is fired, and the spring is tensioned to its extreme limit and serves to eject the cartridge from the barrel with considerable force only at such time as the barrel reaches the limit of its downward movement.

The means 4 for moving the extractor-bar a limited distance independently of the mechanism just described consists of a plunger reciprocally movable in the frame of the gun, one end being adapted to engage the shoulder 7 of the extractor-bar and the other end being arranged to engage a suitable shoulder 25, formed on the forward end of the gun-frame. By thus interposing the plunger 4 between the shoulder 7 of the movable barrel and the fixed shoulder 25 of the gun-frame it is apparent that when the gun is broken the extractor-bar will be moved a limited distance for starting the cartridge from the barrel. This feature of my invention not only permits a loaded cartridge to be withdrawn by hand, if desired, but also relieves the work of the spring-arm 13 and tumbler 2 after the cartridge has been fired and the gun moved to the limit of its downward movement for forcibly ejecting the cartridge.

Although I have shown and described an ejector mechanism for a single barrel, I have shown a double-barreled gun, each barrel being provided with one of the described mechanisms which operate independently of each other.

The cocking-lever previously referred to may be of any desired form or construction,

and while I have shown a rock-shaft having its forward end provided with a laterally-extending arm having an engaging shoulder for engaging the shoulder 22 of the sear 3 and
5 its rear end provided with a cam for engaging the shoulder on the hammer and rocking the same to its cocked position, yet it is obvious that I may employ a reciprocally-movable bar operating for the same purpose as the rock-
10 bar *a* herein shown and described.

The fore-end piece upon which the mechanism for operating the extractor-bar is mounted is provided with an inclined face 26, which engages the forward end of the cock-
15 ing-bar for rocking the same when the gun is broken, and thereby automatically cocking the hammer in the usual manner.

The operation of my invention will now be readily understood upon reference to the fore-
20 going description and the accompanying drawing, and it will be noted that considerable change may be made, in the detail construction and arrangement of the parts of my
25 invention without departing from the spirit thereof. Therefore I do not limit myself to such precise construction and arrangement as herein shown and described.

Having thus described my invention, what I claim, and desire to secure by Letters Pat-
30 ent, is—

1. In a breech-loading firearm, an ejector mechanism comprising a spring-actuated extractor-bar, in combination with a hammer, and means controlled by the hammer for pre-
35 venting the tensioning of the spring when the hammer is cocked.

2. In a breech-loading firearm, an ejector mechanism comprising an extractor-bar, a spring-actuated tumbler for moving the ex-
40 tractor-bar, means movable into and out of the path of movement of the tumbler for the purpose described, in combination with a hammer, and a cocking-bar for controlling the position of said means as the hammer as-
45 sumes its cocked and firing positions.

3. In a breech-loading firearm, an ejector mechanism comprising an extractor-bar, a spring-actuated tumbler for moving the ex-
50 tractor-bar, a sear reciprocally movable into and out of the path of the tumbler for the purpose described, in combination with a hammer, and a cocking-bar for controlling the position of the sear as the hammer is cocked or fired.

4. In a breech-loading firearm, an ejector mechanism comprising an extractor-bar, a spring-actuated tumbler for moving the ex-
55 tractor-bar, a movable sear, a spring for forcing the sear into the path of the tumbler, in
60 combination with a hammer, and a cocking member adapted to hold the sear out of the path of the tumbler when the hammer is cocked.

5. In a breech-loading firearm, an ejector
65 mechanism comprising an extractor-bar, a spring-actuated tumbler for moving the ex-tractor-bar, a spring-actuated sear for hold-

ing the tumbler in its inoperative position and means for forcing the sear to its operative position when the gun is dis- broken.

6. In a breech-loading firearm mechanism with the frame and barrel mechanism mounted on the frame comprising an extractor-bar, a spring-actuated tumbler for actuating the bar, and means for controlling the movement of the tumbler, a sear mounted on the frame and the hammer for controlling the position of the sear.

7. In a breech-loading firearm mechanism with the frame and barrel mechanism mounted on the frame comprising an extractor-bar, a spring-actuated tumbler for actuating the bar, and means for controlling the movement of the tumbler, a sear engaged with the frame for forcing the sear to its inoperative position when the gun is broken.

8. In a breech-loading firearm mechanism with the frame and barrel mechanism mounted on the frame comprising an extractor-bar, a spring-actuated tumbler for actuating the bar, and means for controlling the movement of the tumbler, a sear mounted on the frame and the hammer for controlling the movement of the sear in its inoperative position when the hammer is cocked and for forcing the sear to its operative position when the hammer is fired, and means for forcing the sear to its operative position when the hammer is fired.

9. In a breech-loading firearm mechanism with the frame and barrel mechanism mounted on the frame comprising an extractor-bar, a spring-actuated tumbler for actuating the bar and provided with a support, and spring-arms responding ends movably mounted on the support and their opposite ends engaged with the frame and with the sear.

10. In a breech-loading firearm mechanism with the frame and barrel mechanism mounted on the frame comprising an extractor-bar, a spring-actuated tumbler for actuating the bar and provided with a support, and spring-arms responding ends movably mounted on the support and their opposite ends engaged with the frame and with the sear, a spring-actuated sear movable into and out of the path of the tumbler, said sear being forced into the path of the tumbler by the spring engaging with the frame and the sear broken for the purpose described.

11. In a breech-loading firearm mechanism with the frame and barrel mechanism mounted on the frame comprising an extractor-bar, a spring-actuated tumbler for actuating the bar and provided with a support having an inclined face, and spring-arms having corresponding ends mounted on the inclined face and their opposite ends engaged with the frame and with the cam on the tumbler for the purpose described.

