

No. 748,510.

PATENTED DEC. 29, 1903.

W. KOEPER.
COFFIN GUIDE.

APPLICATION FILED FEB. 20, 1903.

NO MODEL.

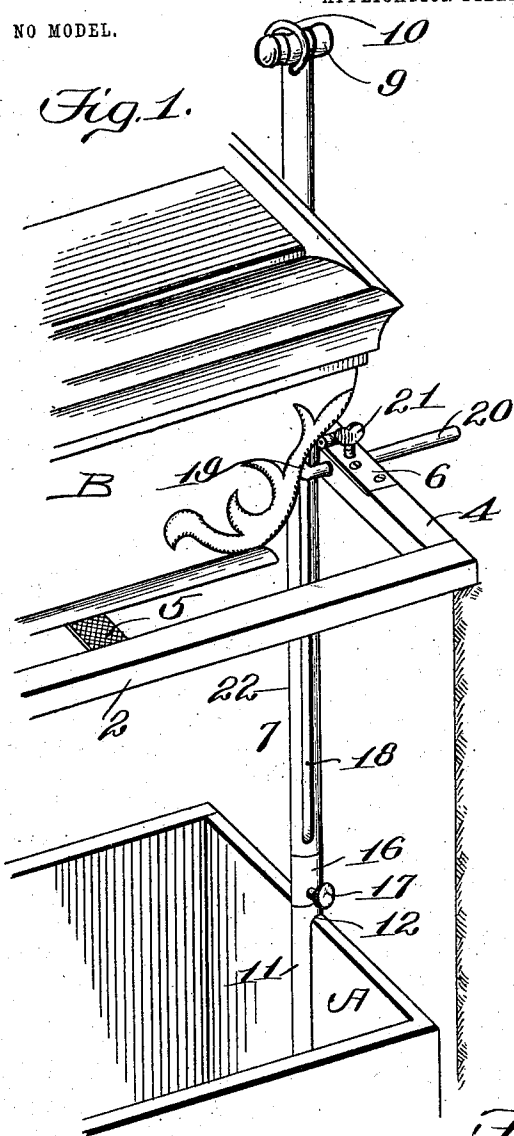

Fig. 1.

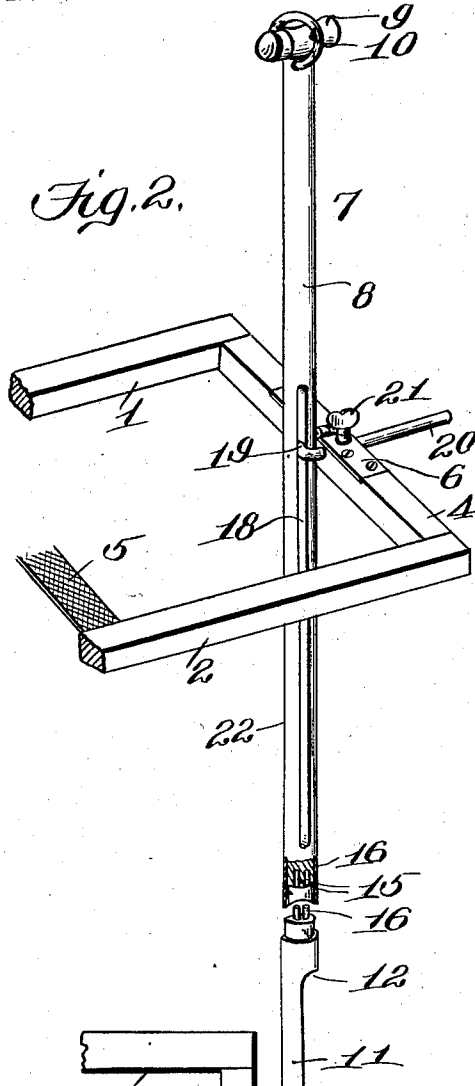

Fig. 2.

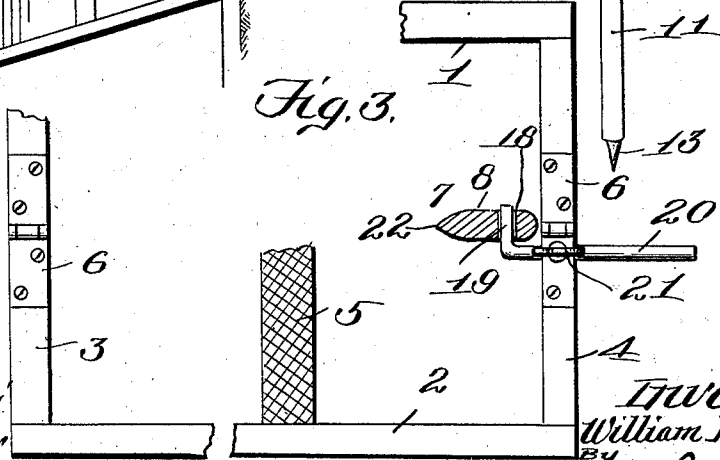

Fig. 3.

Witnesses:
Ed. Mesley
James L. Norris, Jr.

Inventor
William Koepfer
 BY
James L. Norris
 ATTORNEY

UNITED STATES PATENT OFFICE.

WILLIAM KOEPER, OF FORT DODGE, IOWA.

COFFIN-GUIDE.

SPECIFICATION forming part of Letters Patent No. 748,510, dated December 29, 1903.

Application filed February 20, 1903. Serial No. 144,312. (No model.)

To all whom it may concern:

Be it known that I, WILLIAM KOEPER, a citizen of the United States, residing at Fort Dodge, in the county of Webster and State of Iowa, have invented new and useful Improvements in Coffin-Guides, of which the following is a specification.

This invention relates to certain new and useful improvements in coffin-guides.

The object of the invention is in a ready, simple, thoroughly feasible, certain, and practical manner and without noise and ostensive manipulations to effect guiding of a coffin into its case. Furthermore, to reduce the labor incidental to such operation to a minimum.

With these and other objects in view, as will appear as the nature of the invention is better understood, the same consists, generally stated, in a device adapted to perform the functions of a coffin guide and adjusting device, the first function being secured by the provision of a vertical guiding edge against which one end of the coffin is adapted to bear in its descent into the case and the second function being secured by imparting a rotary movement to the implement to cause it to correct any deviation in the descent of the coffin which would operate to prevent it from squarely entering the case.

The invention further contemplates means to effect proper placing of the coffin-lowering apparatus with relation to the case to insure proper descent of the coffin, the function being secured by the provision of means coacting with the lowering apparatus to hold the guide in plumb position.

The invention consists, furthermore, in the novel construction and combination of parts of a coffin-guide, as will be hereinafter fully described and claimed.

In the accompanying drawings, forming a part of this specification, and in which like characters of reference indicate corresponding parts, there is illustrated one form of embodiment of the invention capable of carrying the same into practical operation, it being understood that the elements therein exhibited may be varied or changed as to shape, proportion, and exact manner of assemblage without departing from the spirit thereof.

In the drawings, Figure 1 is a view in sectional elevation displaying the manner in which the guide is employed when a coffin or casket is being lowered into a grave. Fig. 2 is a view in perspective of the completed apparatus. Fig. 3 is a view in plan, partly in section.

The guide of this invention is adapted for use in connection with an ordinary burial-casket-lowering apparatus such as are in common use and which, as shown in Fig. 2, comprises side bars 1 and 2, end bars 3 and 4, and casket-supporting belts or straps 5, with which are combined means for raising and lowering them, not necessary to be shown, as it forms no part of the present invention and will be readily understood. The end bars 3 and 4 are made in two parts hinged together at 6 to facilitate handling of the device.

The guide 7 comprises in its construction two sections constructed, preferably, of wood, the upper section 8 being essentially ovoid in cross-section, as shown in Fig. 3, and has connected with it a handle 9 and a ring 10, the function of which will presently appear. The lower section 11 is reduced, as at 12, to form a flat bearing-face and is provided at its lower end with a prod or prong 13, which, as shown in Fig. 1, is adapted to be sunk into the case A and bear against the end thereof. The lower section 11 may be detachably connected in any preferred manner with the upper section 8, and in this instance the assemblage is shown as effected by providing said lower section with dowel-pins 14 to fit within sockets 15 in the upper section. A collar or sleeve 16 is secured to the upper section to increase the rigidity of the connection. To prevent accidental separation of the sections in use, a set-screw 17 is provided which passes through the sleeve and into the lower section. The rod is provided with a longitudinal slot 18, which is disposed adjacent to its rear edge and is adapted to be engaged by the angular end 19 of an adjustable arm 20, mounted in one of the end pieces of the frame of the lowering apparatus a set-screw 21, carried by the end piece operating positively to clamp the arm at any desired adjustment. As shown in Fig. 3, the inner face of the section

8 of the rod 7 is provided with a comparatively sharp bearing, as at 22, for a purpose that will presently appear.

The arrangement and operation of the guide 5 and the coacting parts is as follows: The frame of the lowering apparatus is placed over the mouth of the grave, as usual, the case A having been previously placed in the grave. In order to determine positively the 10 position the casket B is to occupy upon the lowering apparatus, the ring 10 is grasped and the rod is lowered into the grave, with the reduced rear edge thereof bearing against one end of the case, and when the rod is perfectly plumb the prong 13 is forced into the 15 bottom of the case, and the rod is held in this position and the lowering apparatus is moved up against its rear edge, after which the angular end of the arm 20 is passed into the slot 18 and is locked there by the set-screw 21. The mechanism of the lowering apparatus is then operated to cause the casket to descend, its end riding against the sharp edge of the rod, and should the coffin veer or 25 have a tendency to move sidewise, which might result if the straps 5 were not evenly released to compensate for this deviation, the set-screw 21 will be loosened and the angular end of the arm 20 thrown out of engagement 30 with the slot 18, whereupon by rotating the rod either to the right or left, as the case may be, the sharp edge of the rod by frictional engagement with the casket will cause the latter to respond to the direction of movement 35 of the rod, and the deviation above referred to will be counteracted, and the casket will be caused positively to enter the case without touching the sides thereof. After the casket has been deposited the lowering apparatus is removed in the usual manner and 40 the sections of the rod will be separated, and the whole may then readily be transported from the place of burial.

While the implement of this invention is 45 exceedingly simple of construction, it will be found thoroughly efficient in use for the purpose designed and will be found in a practical manner to obviate difficulties heretofore always attending the depositing of a casket within a grave.

Having thus described the invention, what I claim is—

1. A device of the class described comprising a rod or staff, means for effecting plumb-

ing thereof, means for holding it in plumbed 55 position, and means for imparting rotary motion thereto.

2. A device of the class described comprising a rod or staff having its lower end provided with a holding device and its upper 60 end with a handle, the intermediate portion of the staff being provided with a slot, a locking device to engage the slot to hold the rod in adjusted position, and means for supporting the locking device. 65

3. A device of the class described comprising a sectional rod or staff, means for holding the sections thereof detachably assembled, a holding device carried by the lower 70 section, an operating-handle carried by the upper section, and means carried by the upper section to hold the device in plumbed position.

4. A device of the class described comprising a staff or rod approximately ovoid in cross-section to provide a sharp bearing edge, holding means carried by the lower end of the staff, and an operating-handle carried by the upper end thereof. 75

5. A device of the class described comprising a rod or staff having its lower end incut or recessed and provided with a holding device, and a handle carried by the upper end 80 of the device, the staff being provided with a sharpened edge, for the purpose specified. 85

6. A device of the class described comprising a sectional rod or staff, a prod or point carried by the lower section, a handle and a ring carried by the upper section, and means for holding the sections detachably connected. 90

7. The combination with a casket-lowering apparatus, and an adjustable hooked arm carried thereby, of a guiding and adjusting device comprising a rod or staff provided at its 95 lower end with a prod to engage the coffin-case and at its upper end with a handle and with a ring and intermediate of its ends with a slot to be engaged by the hooked arm to hold the guiding and adjusting device properly disposed with relation to the lowering device. 100

In testimony whereof I have hereto set my hand in presence of two subscribing witnesses.

WILLIAM KOEPER.

Witnesses:

JOHN LAUFENWEILER,
GEO. M. BEICHER.