

K. VÖLLER.
SHELL FUSE.

APPLICATION FILED MAR. 9, 1911.

1,000,862.

Patented Aug. 15, 1911.

2 SHEETS—SHEET 1.

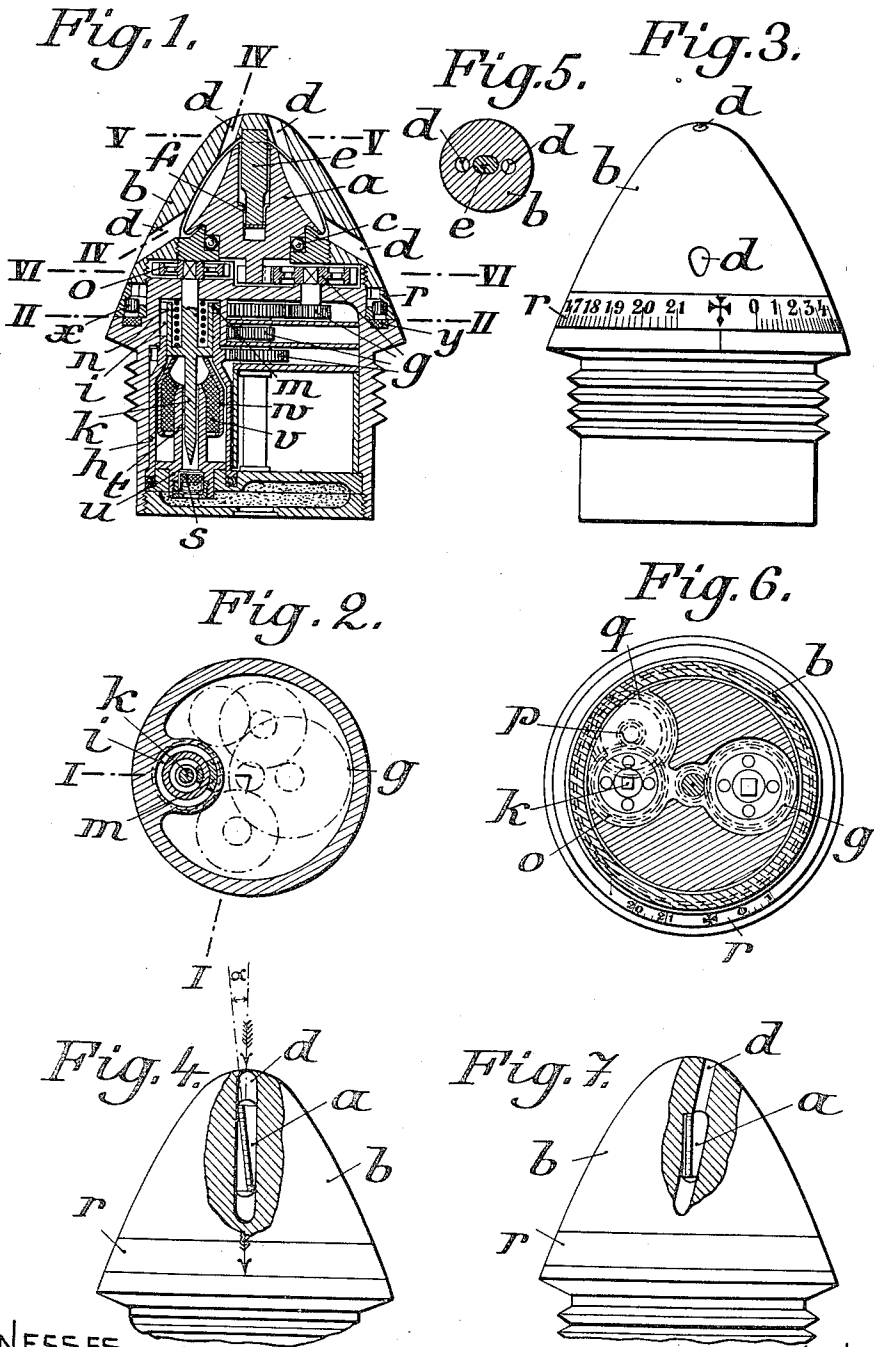

WITNESSES

Franz S. Krasner
John A. Murphy

INVENTOR

Karl Voller
by *J. M. ...*

K. VÖLLER.
SHELL FUSE.

APPLICATION FILED MAR. 9, 1911.

1,000,862.

Patented Aug. 15, 1911.

2 SHEETS-SHEET 2.

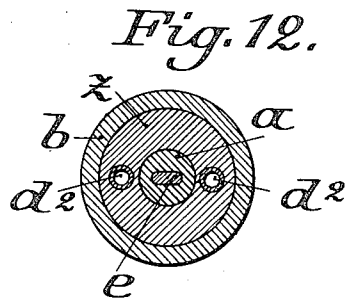
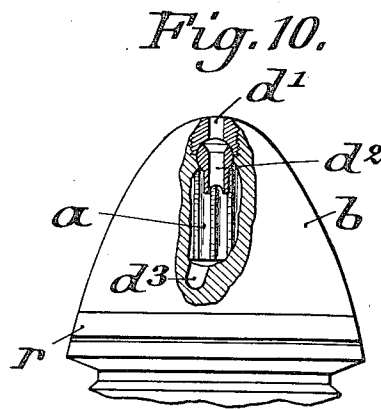
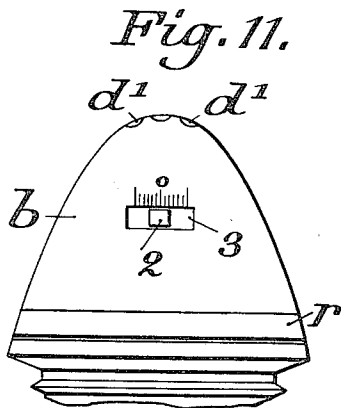
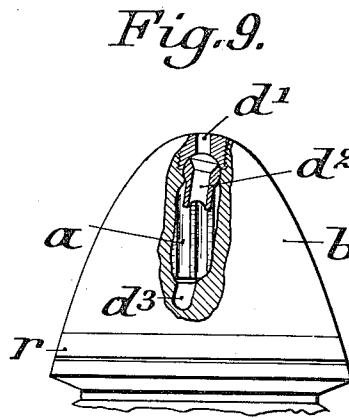
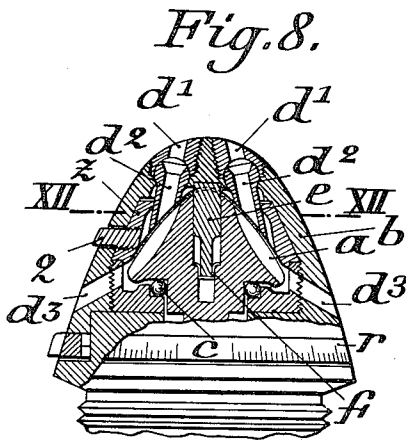

WITNESSES

Francis S. Maguire
John A. Murphy

INVENTOR

Karl Voller,
by J. H. ...
Attorney

UNITED STATES PATENT OFFICE.

KARL VÖLLER, OF DUSSELDORF, GERMANY, ASSIGNOR TO RHEINISCHE METALLWAAREN- UND MASCHINENFABRIK, OF DUSSELDORF-DERENDORF, GERMANY, A CORPORATION OF GERMANY.

SHELL-FUSE.

1,000,862.

Specification of Letters Patent. Patented Aug. 15, 1911.

Application filed March 9, 1911. Serial No. 613,324.

To all whom it may concern:

Be it known that I, KARL VÖLLER, engineer, a subject of the German Emperor, residing at 12 Scharnhorststrasse, Düsseldorf, Germany, have invented certain new and useful Improvements in Shell-Fuses; and I do hereby declare the following to be a full, clear, and exact description of the invention, such as will enable others skilled in the art to which it appertains to make and use the same.

My invention relates to improvements in shell fuses and more particularly to fuses of that class in which explosion is caused by means of a bladed wheel which is moved by a current of air produced by the flight of the shell. In devices of this character such as are now in use the wheel is freely located in front of the head of the projectile or within a cavity of the said head, so that the admission of the air to the wheel is unobstructed and irregular.

The object of my improvements is to so arrange the said wheel, that its action is perfectly regular, so that the movement of the wheel, and therefore the time of ignition depends on the distance of the projectile from the gun independently of its velocity.

With this object in view my invention consists in completely inclosing the wheel within the body of the shell and conducting the air thereto through passages provided in the head of the shell, so that for a certain path of the shell always a definite amount of air is admitted to the wheel. By thus constructing the igniter the latter can be set so as to cause explosion at any desired distance from the gun, and it can have the same construction for projectiles of different character, whether the velocity of the latter be large or small. Therefore the same fuse can be used in projectiles of different construction. The arrangement of the wheel within the head of the fuse is advantageous also in this respect, that it is thereby protected against injury.

The invention will be hereinafter fully set forth and particularly pointed out in the claims.

For the purpose of explaining the invention several examples embodying the same have been shown in the accompanying drawings in which the same letters of reference have been used in all the views to indicate corresponding parts.

In said drawings Figure 1, is a vertical section of the head of a projectile containing the fuse, in which the blades of the wheel are disposed at an angle to a plane passing through the longitudinal axis of the shell, Fig. 2, is a horizontal section of the same taken on the line II—II of Fig. 1, Fig. 3, is a side view of the head shown in Fig. 1, Fig. 4, is a side view partly in section of the head of the projectile. Fig. 5, is a horizontal section taken on the line V—V of Fig. 1, Fig. 6, is a horizontal section of the head taken on the line VI—VI of Fig. 1, Fig. 7 is a side view partly in section of the head of a shell embodying a modification of the construction shown in Figs. 1-6, the blades being arranged parallel and the passages at an angle to a plane passing through the longitudinal axis of the shell, Fig. 8 is a vertical section of a modification of the fuse in which the direction of the passages for conducting the air to the bladed wheel is variable, Fig. 9, is a side view of Fig. 8 similar to that shown in Fig. 4, Fig. 10 is a view similar to Fig. 9 with the parts in different position. Fig. 11, is a further side view of the head shown in Fig. 8, and Fig. 12, is a horizontal section of the head taken on the line XII—XII of Fig. 8.

Referring to the example illustrated in Figs. 1 to 6 of the drawings, the bladed wheel *a* is mounted within a cavity of the fuse *b* so as to rotate on balls *c*. The fuse is formed with a plurality of bores or passages *d* through which the air passes during the flight of the shell. The passages are formed in such a way, that the air strikes against the blades of the wheel *a* so as to rotate the same. The larger the velocity of the shell is, the faster rotates the bladed wheel, but the bladed wheel has made a definite number of revolutions, when the projectile has passed through a certain path. In its out of use position the bladed wheel *a* is protected against rotation by means of a longitudinally slidable bolt *e* of elongated cross-section which is normally held in engagement with a notch of the fuse head by a spring *f*. When the shell is discharged from the gun, the spring *f* is compressed by the inertia of the bolt, so that the latter disengages the notch within the head of the projectile and permits rotation of the bladed wheel. The rotation of the bladed wheel *a* is transmitted through intermediary gear

wheels g to a sleeve h disposed at the side of the fuse. The upper reduced portion of the said sleeve is formed with a longitudinal slit i . Within the sleeve a spring actuated firing pin k is longitudinally slidable which normally is locked against displacement by a nose m bearing on the upper face of the sleeve h . The firing pin can not be thrown forward by its spring n , before the sleeve h has been turned into a position in which the slit i is in register with the nose m . At its upper end the firing pin is formed with a head of square section, and it is in engagement with a toothed wheel o . The latter is in mesh with another gear wheel p on the shaft of which a further gear wheel q is located. The latter is in engagement with the teeth of a setting ring r which is rotatable on the fuse head. By rotating the setting ring the firing pin is rotated and the nose m is adjusted relatively to the slit i , so that the bladed wheel must make a corresponding number of revolutions, and the shell is thrown through a corresponding distance, in order to bring the slit i into register with the nose m and to enable the spring n to throw the firing pin against the fuse s .

With the device constructed as described the firing pin might be thrown into operation by rotating the setting ring so far that the slit i , registers with the nose m . To prevent in this case ignition of the fuse the shaft t of the fuse carrier u is equipped with a block v of lead or other soft material. The said block is inclosed within a casing w which with its upper annular face bears against the firing pin k and prevents the same from being thrown rearward during transportation even if the slit i and nose m are in register. Upon the initial shock caused by firing the gun the said block v is thrown backward on the shaft t so that the casing w releases the firing pin. However, at the beginning the firing pin is locked against being thrown rearward, until the shell has passed through the distance to which the setting ring has been adjusted. To prevent rotation of the setting ring during the flight of the projectile pins x are disposed within notches of the said ring, and a ring y of soft material is located at the rear of the ring. Upon the initial shock the bolts x are thrown backward and into the soft ring, so as to prevent rotation of the setting ring.

The fuse combines the functions of a time fuse and a concussion fuse. As stated above the block v and the casing w are thrown backward upon the shaft t of the fuse carrier upon the initial shock caused by firing the gun. The fuse carrier is loosely mounted within the sleeve h and it is thrown forward by impact against the firing pin and causes ignition of the shell, when the latter strikes on the aim. The fuse can

also be set by adjusting the inclination of the blades of the bladed wheel, or by varying the direction of the passages for the air. An example of such a construction is shown in Figs. 8 to 12.

The blades of the wheel a and the front parts d' of the air passages are located within a plane which passes through the longitudinal axis of the shell. The front ends of the air passages are extended rearward through a part d^2 which can be turned with its ball shaped head within a correspondingly shaped cavity of the head of the shell. The lower ends of the parts d^2 are engaged by a rotary ring z which is provided with a nose 2 projecting through a slot of the casing of the fuse. The slot 3 permits adjustment of the nose 2 and the ring z . By setting the ring z the parts d^2 , the bores of which connect the passages d' and the outlet passages d^3 , assume a different inclination relatively to the blades of the bladed wheel a whereby the number of revolutions of the said wheel is effected. In Figs. 9 and 10 I have shown the parts d^2 in different positions.

I claim herein as my invention:

1. In a shell the combination with a fuse having a cavity and passages extending from said cavity to the front side of the shell and rearward, and igniting means, of a wheel rotatably mounted within the said cavity and adapted to be rotated by air passing through said passages, and an operative connection between said wheel and the igniting means adapted to cause ignition of the fuse after rotation of said wheel.

2. In a shell the combination with a fuse, having a cavity and passages extending from said cavity to the front side of the shell and rearward, and igniting means, of a wheel rotatably mounted within the said cavity and adapted to be rotated by air passing through said passages, an operative connection between said wheel and igniting means adapted to cause ignition of the fuse after rotation of said wheel, and locking means for said wheel adapted to be made inoperative by the initial shock caused by the discharge of the shell from the gun.

3. In a shell the combination with a fuse having a cavity and passages extending from said cavity to the front side of the shell and rearward, and igniting means, of a wheel rotatably mounted within the said cavity and adapted to be rotated by air passing through said passages, an operative connection between said wheel and fuse adapted to cause ignition of the fuse after rotation of said wheel, and a pin within said wheel at the front side thereof, said pin having an elongated cross-section and being slidable within said wheel longitudinally of the axis of the shell and normally pressed into a notch of said shell by a spring.

70

75

80

85

90

95

100

105

110

115

120

125

130

4. In a shell the combination with a fuse
having a cavity and passages extending from
said cavity to the front side of the shell
and rearward, and igniting means, of a
5 wheel rotatably mounted within the said
cavity and adapted to be rotated by air
passing through said passages, means to
vary the relative position of said passages
and the parts of said wheel adapted to be
10 engaged by the air flowing through said
passages, and an operative connection be-

tween said wheel and igniting means adapt-
ed to cause ignition of the fuse after rota-
tion of said wheel.

In testimony whereof, I have signed this 15
specification in the presence of two sub-
scribing witnesses.

KARL VÖLLER. [L. s.]

Witnesses:

WALTER VONNEGUT,
ALFRED HENKEL.