



Europäisches Patentamt
European Patent Office
Office européen des brevets



(11) **EP 1 006 854 B1**

(12) **EUROPEAN PATENT SPECIFICATION**

(45) Date of publication and mention
of the grant of the patent:
15.06.2005 Bulletin 2005/24

(51) Int Cl.7: **A47L 7/00**, E01H 1/08,
A47L 11/40

(21) Application number: **97934883.6**

(86) International application number:
PCT/US1997/011694

(22) Date of filing: **02.07.1997**

(87) International publication number:
WO 1998/000239 (08.01.1998 Gazette 1998/01)

(54) **SURFACE CLEANER, SPRAYER AND RETRIEVAL UNIT**

EINRICHTUNG ZUM REINIGEN VON OBERFLÄCHEN MIT SPRÜZERSTÄUBER UND
WIEDERVERWENDUNGSEINHEIT

NETTOYEUR DE SURFACES AVEC PULVERISATEUR ET SYSTEME DE RECUPERATION

(84) Designated Contracting States:
DE ES FR GB IT

• **GRAVES, Nelson, D.**
Phoenix, AZ 85020 (US)

(30) Priority: **02.07.1996 US 21062 P**
04.11.1996 US 746025

(74) Representative: **Bayliss, Geoffrey Cyril et al**
BOULT WADE TENNANT,
Verulam Gardens
70 Gray's Inn Road
London WC1X 8BT (GB)

(43) Date of publication of application:
14.06.2000 Bulletin 2000/24

(73) Proprietor: **Cyclone Surface Cleaning, Inc.**
Tempe, AZ 85281 (US)

(56) References cited:
US-A- 935 559 **US-A- 1 093 820**
US-A- 3 032 955 **US-A- 3 624 668**
US-A- 3 778 864 **US-A- 3 959 010**
US-A- 4 107 816 **US-A- 4 191 590**
US-A- 4 377 018 **US-A- 5 428 863**
US-A- 5 500 976

(72) Inventors:
• **ROHRBACHER, Richard, D.**
Phoenix, AZ 85018 (US)
• **MARLEY, Kemper, Jr.**
Scottsdale, AZ 85254 (US)

EP 1 006 854 B1

Note: Within nine months from the publication of the mention of the grant of the European patent, any person may give notice to the European Patent Office of opposition to the European patent granted. Notice of opposition shall be filed in a written reasoned statement. It shall not be deemed to have been filed until the opposition fee has been paid. (Art. 99(1) European Patent Convention).

Description**BACKGROUND OF THE INVENTION**

[0001] The present invention relates generally to a mobile system for processing flat surfaces and includes a cyclonic power wash system that uses sprayed water for cleaning flat surfaces such as concrete, asphalt, and other various hard surfaces.

[0002] Aircraft are sprayed with deicing fluid while on the airport apron or runway. Much of the deicing fluid falls to the flat surface and collects in the expansion joints and cracks formed therein. If this fluid is not quickly removed it will run through the cracks and joints of the surface and eventually find its way into the rivers, lakes and streams. The present invention also relates to a pick up or processing system that can efficiently and quickly pick up liquid from a flat surface as well as from the cracks and expansion joints formed therein.

[0003] The present invention also relates to a mobile system for processing flat surfaces that has an improved rotary blade that picks up or reclaims sprayed water and the waste from the surface in an improved manner. A mobile system according to the preamble of the independent claim is known from US-A-5500976.

[0004] The present invention also relates to a power wash system that reclaims and filters sprayed water and then recycles the filtered water to the system for further use in cleaning.

[0005] Apparatus and methods for selectively cleaning flat surfaces using a mobile cyclonic power wash system are well known in the art. The mobile cyclonic power wash system generally sprays water at high rotating speeds to clean the surfaces. A typical mobile cyclonic power wash system includes a water storage means for holding the water that is to be used for cleaning, a water pumping system for pumping and pressurizing the water from the storage means, and a water cyclone sprayer for spraying the water onto the surfaces. Typical power wash system can further include a water heating system for heating the water so that high temperature as well as high pressure water is provided for cleaning surfaces.

[0006] One of the problems with the prior art power wash systems is that they do not have the capability to recover much of the liquid that has been dispersed. As a result the pollutants contained in the unrecovered liquid remains on the surface that is being cleaned. Also the liquid is lost from the system and must be replaced from an outside source provided one is available at the work site. Furthermore the prior art machines do not have the capability to recycle the liquid that is recovered such that the recycled liquid is clean enough to be effective in subsequent cycles. The prior art systems cannot operate as independent, self-contained systems in which the water is continuously reclaimed, filtered, and recycled for further use by the power wash system. Therefore, the operation of the prior art systems is limited

by the amount of water that can be stored or transported by the system (i.e. by the capacity of the water storage means). When operating at a location where fresh water is not available and polluted liquid cannot be deposited at the work site, then the operator of the system must leave the work site, to dispose of the polluted water and to replenish with new clean water from an outside source. As a result, the prior art systems required the use of large amounts of water, and fails to recover much of the waste. Moreover, environmental objections are increasingly being raised against dumping harmful liquid waste into the drainage systems. Thus, there is a need to recover and reclaim most of the water that is sprayed in outdoor cleaning systems. There is also a need to isolate and retain the recovered waste products for acceptable disposal.

[0007] When a surface has been covered with a liquid, such as ethylene glycol, that can not be recycled by a mobile unit, it is desired to recover or pick up the liquid and collect it for processing at other facilities. As a result of the very efficient vacuum system of this invention as well as this systems ability to cover wide swaths by combining groups of individual units into combined units this invention functions as a very efficient pick up system.

[0008] In overcoming the problems and limitations of the prior art, it is an object of the present invention to clean and process flat surfaces using a mobile cyclonic power wash system with a water reclamation system that will recover substantially all of the water that is dispersed. The mobile cyclonic power wash system can also be combined with a filter and recycling system, which reclaims and filters the water sprayed by the power wash system and has the capacity to return close to 100% of the water used by the power wash system. The recovered liquid is processed, which removes and isolates the waste, and the cleaned liquid is stored so that it can be available for the continuous use of the system.

[0009] In providing a device for picking up liquid from a flat surface and from the crevices, cracks and expansion joints formed therein while overcoming the problems and limitations of the prior art, it is an object of the present invention to pick up the liquid with a very efficient and powerful cyclonic power pick up unit that can process a wide swath to thus recover the liquid before it flows away or is absorbed.

[0010] The mobile cyclonic power wash system can also be combined with a filter and recycling system, which reclaims and filters the water sprayed by the power wash system and has the capacity to return close to 100% of the water used by the power wash system. The recovered liquid is processed, which removes and isolates the waste, and the cleaned liquid is stored so that it can be available for the continuous use of the system.

SUMMARY OF THE INVENTION

[0011] This invention relates to a processing system that can use high pressure water for cleaning flat sur-

faces and recovers a substantial portion of the dispersed water that contains matter recovered from the surface.

[0012] The processing system can also function as a pick up system to recover liquids that have been deposited on the surface to prevent their absorption and contamination of the environment. These recovered liquids can then be safely disposed of or recycled. The system includes a water storage means for holding water to be used for cleaning, a water pumping system for pumping and pressurizing the water and a cyclone sprayer for spraying the water onto the surface. An improvement in the system includes a power driven retrieval rotor that picks up nearly all the liquid that has been sprayed by the system. The recovered liquid can then be filtered, processed and placed in a storage means so that it can be further used for cleaning by the system. The system also preferably includes a water heater for heating the water.

[0013] A preferred feature of the invention is the construction of the filtration tank which includes an inlet at the top, a removable slanting trough below the inlet with a screened outlet at the bottom of the trough for filtering large matter from the water, a plurality of cascading chambers for allowing the water to successively fill a chamber and flow over into an adjacent chamber leaving behind smaller matter still present in the water continuously passing cleaner water to the next chamber.

[0014] A still further preferred feature of the invention is a mobile platform on which the system components are mounted for transport to a job site.

[0015] A further preferred feature of the invention is in the water cyclone sprayer of the power wash system, which sprays high pressure, high temperature water at a high rotating speed. An improvement in this sprayer is in the rotary union seal, which is formed between two silicon carbide surfaces, one stationary and the other rotatable at high rpm with the water passing through a central bore through the sealing members which prevents leakage through the rotary union seal, and an o-ring which prevents leakage around the rotary union seal.

[0016] A further preferred feature of the invention is the method of effecting a leak proof seal in the rotary union which includes a non-rotatably, slidingly mounted a cylindrical support member which has affixed to one end thereof a first silicon carbide seal face. The support member has a central bore there through and the sliding mounting forms an interface between a central bore formed in the housing and the outer surface of the cylindrical support member. This feature of the invention further includes sealing the interface by sandwiching an o-ring between the other end of the cylindrical support member and a downwardly biased washer with the o-ring that engages the housing central bore. A spindle having a second silicon carbide seal face affixed to its end that is adjacent the cylindrical support member is supported within another central bore. The spindle has

a central bore formed therein to its discharge end; thereby, forming a rotary union by sealingly engaging the first and second silicon seal faces. In this method fluid, i.e. water, entering the inlet end of the housing passes through the central bores of the members, o-ring, spindle and rotary union and out the discharge end of the spindle without leaking around or through the seal at the rotary union.

[0017] A further preferred feature of the invention includes supporting the inner bore of the o-ring by a downwardly axially extended inner bore portion of the biased washer and an upwardly axially extended inner bore portion of the other end of the cylindrical support member. This construction prevents the o-ring from being blown into the central bore of the cylindrical support member by the high pressure water present at the interface.

[0018] A further preferred feature of this aspect of the invention includes applying an upward force to the spindle to further sealingly engage the seal faces in reaction to the downward force of the fluid exiting from the nozzles affixed to the retrieval rotor.

BRIEF DESCRIPTION OF THE DRAWINGS

[0019]

Figure 1 is a front perspective view of a mobile power wash system having a water reclamation and filter recycling system and the improved retrieval rotor and rotary union of the present invention.

Figure 2 is a rear elevation view of the mobile power wash system having a water reclamation and filter recycling system taken along the line 2-2 of Figure 1.

Figure 3 is a top rear perspective view of an embodiment of the sprayer and retrieval unit of the present invention including the improved retrieval rotor attached.

Figure 4 is a bottom view of the embodiment of the sprayer and retrieval unit shown in Figure 3.

Figure 5 is a cross-sectional view taken through one of the swept back rods and blades of the retrieval rotor taken along line 5-5 Figure 4.

Figure 6 is a cross-sectional view taken through one of the stabilizers of the retrieval rotor and the vertical wall of the tub taken along line 6-6 of Figure 4.

Figure 7 is a sectional elevation view of a first sub-assembly of components for the improved rotary union of the present invention.

Figure 7A is an enlarged elevation view in partial section of the first floating silicon carbide seal member that is a part of the improved rotary union shown in Fig. 7.

Figure 7B is a bottom elevation view taken along the line 7B-7B of Fig. 7 showing the non-rotational engagement of the upper floating seal support member.

Figure 7C is a perspective view of the upside down T-shaped cylindrical support member.

Figure 8 is a sectional elevation view of the second subassembly of components for the improved rotary union.

Figure 9 is a front sectional elevation view of the water filtration tank for the water reclamation and filter recycling system of the present invention.

Figure 10 is a side sectional elevation view of the water filtration tank for the water reclamation and filter recycling system taken along the line 10-10 of Figure 9.

Figure 11 is an enlarged view of the connection between the retrieval rotor and rotating spindle, which is used in both embodiments of the invention.

Figure 12 is a plan view of another embodiment of a sprayer and retrieval unit including a power driven pump for discharging the retrieved water.

Figure 13 is a cross section side view of the tank taken along lines 13-13 of Figure 12.

Figure 14 is a cross section end view of the tank taken along lines 14-14 of Figure 12.

Figure 15 is a top front perspective view of an embodiment of the invention in which a plurality of sprayers and retrieval units are hitched together and towed as a unit during operation.

DETAILED DESCRIPTION OF THE PREFERRED EMBODIMENT

[0020] Figure 1 is a perspective view of the mobile cyclonic power wash system 10 which includes a novel roving sprayer and retrieval unit 50 that functions to spray water and reclaim the sprayed water and recovered waste. Figure 2 is a side view of the mobile cyclonic power wash system 10. A mobile component carrying platform 70, Figures 1-2, is provided for mounting and transporting the processing components of the cyclonic power wash system 10. In Figures 1 and 2 the component carrying platform 70 is a flat bed trailer of the type that is towed by a vehicle such as a truck. In the preferred embodiment the component carrying platform 70, for these processing components, is the bed of a truck having a closed cargo section. In this embodiment of the invention a vacuum source 300 and a filtration tank 400 as shown in Figure 9 are used.

[0021] The roving sprayer and retrieval unit 50 is connected to the component carrying platform by a flexible water transporting hose 51 and a water and waste return conduit 61. In the embodiment, illustrated in Figure 1, the hose 51 and conduit 61 are of a length that will permit the component carrying platform 70 to remain stationary while the roving sprayer and retrieval unit 50 cleans a section of surface. In this embodiment when the section, defined by the lengths of hose 51 and conduit 61, is completed the component carrying platform is moved to a new location from which the roving sprayer and retrieval unit 50 process another section.

[0022] As seen in Figs. 1 and 2, the mobile cyclonic power wash system 10 includes a component carrying platform 70 on which a liquid storage component 20 for holding the water to be used for cleaning by the system 10 and a water pumping component 30 for pumping and pressurizing the water from the storage component 20 are mounted. The roving sprayer and retrieval unit 50 sprays the water on the surfaces to be cleaned as well as recovers the sprayed water along with waste recovered from the surface being cleaned. Component carrying platform 70, along with the components carried thereby, is transportable from job site to job site. A water heater component 40 may be included, as part of the power wash system 10, for heating the water.

[0023] As a further option, the power wash system 10 can include a chemical treatment system 90. The treatment system 90 would be used prior to operating the power wash system 10 to apply chemicals to the surfaces to be cleaned for the purpose of loosening hard to remove dirt, grease, oil, grime, and the like from the surface. The treatment system 90 comprises an independently power operated pump 91 which pumps chemicals through a hose 92 to a spray gun 93. The chemicals are sprayed on the surfaces to be cleaned through spray gun 93.

[0024] During operation of the power wash system 10 water in the storage component 20 is pumped and pressurized by the pumping system 30. The pumping system 30 is typically a water pump that is driven by a gas-powered engine 31 which also powers a generator 35. The water may then be either pumped to the water heater component 40 if hot water is desired or pumped directly to the roving sprayer and retrieval unit 50 if hot water is not desired. The water heater component 40, burns diesel fuel that is stored in fuel tank 41 to heat the water. The water is heated to an operating temperature of 250°F. An electrical thermostatic switch (not shown) turns the oil burner "on" when the water temperature falls to 230°F and "off" when the water temperature rises to 255°F.

[0025] The water is directed through a water transporting hose 51 and lever type on/off valve 58 to the roving sprayer and retrieval unit 50. The water under high pressure and/or high temperature is sprayed by the roving sprayer and retrieval unit 50 onto the surfaces to be cleaned.

[0026] As shown in Fig. 1, the roving sprayer and retrieval unit 50 comprises a mobile frame 52 having a handle 53 secured thereto that allows an operator to walk behind and control the movement of the roving sprayer and retrieval unit 50. An inverted tub or shroud 73 is secured to the under surface of the mobile frame 52. The discharge end of the flexible water transporting hose 51 is seen connected to the rotary union 100 and a power drive such as an internal combustion engine 56 is shown mounted on the mobile frame 52. Engine 56, as shall be discussed in more detail, drives the retrieval rotor 59. Although this power source is disclosed as an

internal combustion engine 56 the use of a 12 volt electrical engine is also contemplated.

[0027] Figure 3, which is a perspective view of the roving sprayer and retrieval unit 50, discloses the mobile frame 52 that is supported from the ground surface by four wheels 54. A handle 53 is secured to the mobile frame 52 that allows an operator to walk behind and control the water flow to and movement of the roving sprayer and retrieval unit 50. An inverted tub or shroud 73 is secured to the under surface of the mobile frame 52. The discharge end of the flexible water transporting hose 51 is connected to the rotary union 100 through which pressurized water passes to the water discharge jets 55. An internal combustion engine 56 is mounted on the mobile frame 52. Engine 56, drives the retrieval rotor 59 through a shaft drive or belt 62 and sheave 69. The inverted tub or shroud 73 is provided with a pair of exit ducts 78 that are spaced 180 degrees from each other. Each exit duct 78 empties into a conduit 63 and both conduits 63 merge into the waste return conduit 61. A rotary union, such as the rotary union 100 shown in Figures 7, 7A, 7B, 7C and 8 is mounted underneath cover 57. The retrieval rotor 59 is attached to the spindle or rotating shaft 170 of the rotary union 100. This power wash system 10 is extremely efficient at cleaning dirt, grease, oil, grime, and the like from flat surfaces such as asphalt and concrete floors.

[0028] Figure 4, a bottom view of the roving sprayer and retrieval unit 50, discloses the internal surface of the inverted tub or shroud 73. The retrieval rotor 59 is mounted for rotation within the confines of the inverted tub or shroud 73. The retrieval rotor 59, includes swept back rods 65 that, in the preferred embodiment, are secured by welding to the rotating spindle or hollow shaft 170 of the rotary union 100. Another alternative would be to provide the retrieval rotor 59 with a central hub that could be secured to the spindle or hollow shaft 170. As shall be discussed later in greater detail the rotating spindle or hollow shaft 170 has a central bore 161, and functions as a hollow shaft that receives water under pressure that has flowed through the rotary union 100. The retrieval rotor 59 rotates in the direction indicated by arrow R such that the rods 65 appear as swept back. Although the retrieval rotor 59 of the preferred embodiment has eight swept back rods 65, the number is not critical and more or fewer rods could be used. Water discharge jets 55, spaced 180 degrees from each other, are secured to the extremities of two of the swept back rods 65.

[0029] A curved blade 66 having a bottom forwardly extending lip 67 is secured to each of the swept back rods 65. The blades 66 are swept back in the same curvature as the swept back rods 65 and have flat front facing curved surfaces 68. The curved blades 66 are formed along a radius that is equal to the radius of the inverted tub or shroud 73 and their length is about 1/8 the circumference of the inverted tub or shroud 73. Thus, eight blades 66 can be fabricated from a hoop

having a diameter equal to the diameter of the inverted tub or shroud 73. A cross section of a blades 66 is shown in Figure 5. The lip 67 extends forward, into the direction of rotation, and functions to prevent water on the surface of the blade 66 from flowing off the bottom edge. As the retrieval rotor 59 rotates, the blades 66 function as fan blades that pick up water and debris from the underlying surface. The water flows, as a result of centrifugal force, along the flat curved surface 68 of the blades 66 toward the outer extremities of the blades 66. A stabilizer 77 connects the outer extremity of each blade 66 to the next adjacent blade. The stabilizers 77 function to prevent twisting and flexing of the retrieval rotor 59.

[0030] As best seen in Figure 6, which is a cross section view of the rim 74 of the inverted tub or shroud 73, the rim 74 of the inverted tub or shroud 73 has a lip 75 formed thereon. The outer extremities of the blades 66 extend into a channel 76 formed by the upper surface of the inverted tub or shroud 73, its rim 74 and lip 75. The water that flows off the outer extremities of the blades 66 flow into channel 76 and the momentum of the water causes it to continue flowing in the direction of rotation of the retrieval rotor 59.

[0031] The inverted tub or shroud 73 is provided with a pair of exit ducts 78 that are spaced 180 degrees from each other. A section 79 of the rim 74 of the inverted tub or shroud 73 is flared out to form an opening for each of the exit ducts 78. The stream of water flowing in the channel 76 follows the section 79 into an exit duct 78. Each of the exit ducts 78 are connected by a conduit 63 to the water and waste return conduit 61.

[0032] A brush 85 is secured to the outer lower edge of the rim 74 of the inverted tub or shroud 73. The brush 85 extends downwardly toward the surface being cleaned and serves several functions. The retrieval rotor 59 functions as a fan blade that sucks water and waste up and pumps the water and waste along with a large volume of air out the exit ducts 78. This air is drawn in along the space between the peripheral edge of the rim 74 and the surface being cleaned. The brush 85 functions as a partial seal of this space that controls the magnitude of the vacuum that is created. If the brush 85 is too thick, making it difficult for air to pass therethrough, a vacuum is created under the inverted tub or shroud 73 which attempts to pull the peripheral edge of the rim 74 into contact with the surface. If on the other hand the brush 85 is too thin or too porous, thus permitting air to flow unencumbered through the space, then the vacuum created will be insufficient to lift the water and debris from the surface. Thus, the porosity of the brush 85 is critical to the proper operation of this invention.

[0033] In selecting this brush the objective must be to choose a brush that will permit ambient air to flow into the inverted tub or shroud 73 under the rim 74 and the surface being cleaned. The brush 85 functions as a valve to limit and control the amount of air that can flow into the inverted tub or shroud 73 under the space between the lower edge of the rim and the surface being

cleaned. A second function of the brush 85 is to prevent or retard solid waste such as rocks from being thrown out from under the inverted tub or shroud 73. As a result of the driven retrieval rotor, the contour of the internal surfaces of the inverted tub or shroud 73 and the brush 85 water and waste is very efficiently picked up from the surface being cleaned. Further, as a result of centrifugal force, momentum and the pump action water and debris is forced through the exit ducts 78 into the water and waste return conduit 61.

[0034] Referring now to Figure 11, which is an enlarged cross section view taken along the lines 11-11 of Figure 4, the rotating spindle or hollow shaft 170 of the rotary union 100, sheave 69 and portions of the retrieval rotor 59 are shown. The swept back rods 65, upon which discharge jets 55 are carried are comprised of a single hollow tube that extends through the central bore 161 of the rotating spindle 150. An opening 162 is formed in the portion of the hollow tube 65 that is located in the central bore 161. Water under pressure thus flows from the central bore 161 through opening 162 into the hollow rod 65 and then through the conduits extending through hollow rod 65 to the discharge jets 55. The high pressure water is then discharged to the surface being cleaned through the water discharge jets 55. The swept back rods 65 that do not function as water conduits, could be hollow or solid and are welded to the outer surface of the rotating spindle 150.

[0035] It should be noted that in Figure 11 a second sheave 169 is shown. Sheave 169 is not used with this embodiment of the invention but is used with a subsequently described embodiment. Figure 11 thus illustrates the rotating spindle 150 which can be used with either embodiment of the invention.

[0036] The operation of the retrieval unit 50, as seen in Figures 3-6, will now be discussed. The swept back blades 66 having lips 67 along their lower edges that extend into the direction that the blades travel function as fan blades that force air to move toward the free ends of the blades 66. This creates a vacuum below the blades. The vacuum causes the water and debris to be lifted from the surface being cleaned. As the retrieval rotor 59 rotates the lips 67 function to physically scoop the water up such that it reaches the flat portion of the blade and is then caused by centrifugal force to move toward the free end of the blade.

[0037] The rim 74 of the inverted tub or shroud 73 has a lip 75 that cooperates to retain the water and waste and pump it away from the surfaces to be cleaned. Conduits 63 are attached to an end of exit ducts 78 through which the water and waste is transported to the return conduit 61 and then to the filtration tank 400.

[0038] The water along with stones and other debris flows through the conduit 61 to a filtration tank 400 which, in one embodiment, is assisted by a vacuum source 300 as seen in Figure 9. Vacuum source 300 comprises a vacuum pump 310 and a gas driven motor 320 which drives and operates the pump 310. The vac-

uum source 300 may further comprise a silencer 330 attached to the pump 310 and an exhaust muffler 340 attached to the motor 320 so that the vacuum source 300 may be operated with less noise (i.e. for quieter operations in or near residential areas).

[0039] The water is then passed through the filtration tank 400 so that the water is filtered and cleaned for re-use by the power wash system 10. As shown in Figure 9, the water to be processed in the filtration tank 400 can be drawn to the tank 400 by attaching the conduit 350 of the vacuum source 300 to the clean end of tank 400 (i.e. the right side of tank 400 in Figure 9) using an attaching means 360. The vacuum source creates a low pressure in tank 400. This low pressure is transmitted to the conduit 61 and exit ducts 78 which sucks the water into the exit ducts 78, through conduit 61, and then through the tank 400.

[0040] As shown in Figure 9, the filtration tank 400 comprises a top inlet 410, a removable slanting trough 420 located in the upper portion of the tank, a screened trough outlet 425 located at the lower end of trough 420, a plurality of cascading chambers 430 located in the lower portion of the tank, a drain 432 for each chamber 430, and baffles 433 also located in the central portion of the tank between the screened trough outlet 425 and the vacuum source inlet 350.

[0041] The reclaimed water and waste is passed to the tank 400 through inlet 410, and the water flows downwardly along the trough 420 to the screened outlet 425. Large debris and particles are removed from the water as the water passes through screened outlet 425. Thus, large debris is collected and retained in the trough 420 which is located in the upper portion of the tank 400. The trough 420 can be removed from tank 400 so that the large debris and particles can be easily cleaned from it.

[0042] The water is then successively passed through a plurality of cascading chambers 430. The chambers 430 are each separated by a series of dividing walls 431 that are descending in height. The water successively fills each chamber and then flows over to the next adjacent chamber so that debris and particles still present in the water are left in a chamber 430, and cleaner water is continuously passed to the next chamber. The water is then sufficiently cleaned and available for re-use when it reaches the last chamber 436.

[0043] The filtered water exits the tank 400 through outlet 435 located in the last chamber 436 after passing through a one-way, spring loaded, water check valve (not shown) and is transported by gravity feed or by pump (not shown) through a conduit 440 to storage component 20. This filtered water is then available for reuse by the power wash system 10. If a pump is used to pump the water from the outlet 435 to the storage component 20, the pump may be automatically operated by a float switch (not shown) which regulates the water level between predetermined high (pump ON) and low (pump OFF) water levels. A drain 432 is provided

for each chamber 430 so that the debris and particles that remain in these chambers can be removed.

[0044] A plurality of baffles 433 are located below the trough 420 and generally above the chambers 430 to prevent debris, particles, and water from being directly vacuumed into inlet 350 of vacuum source 300. These baffles 433 ensure that the vacuum source 300 and the reclamation and recycling system 60 operate properly.

[0045] As stated earlier, a rotary union 100 is typically mounted in the central portion of the roving sprayer and retrieval unit 50 on the mobile frame 52. Rotary union 100 functions as a seal and coupling for passing high pressure and high temperature water to the water jets 55. The rotary union is used to maintain the water pressure sufficiently high so that the water jets 55 spray the water downwardly at high speeds.

[0046] A problem with prior art rotary unions has been their short life cycle. The components of the prior art rotary unions experienced excessive wear at a fairly fast rate because of the high pressure and high temperature. The rapid deterioration of these parts would cause the seal of the rotary unions to leak, and the result would be that the roving sprayer and retrieval unit 50 would not function properly or effectively.

[0047] Figs. 7, 7A, 7B and 8 show subassemblies of components for an improved rotary union 100 according to this invention. This rotary union 100 is a more effective coupling for passing high temperature and high pressure water to the water jets 55 without causing any leaks in the roving sprayer and retrieval unit 50 and for sufficiently maintaining the water pressure high enough to be an effective cleaning force. This improved rotary union 100 is also designed to be more durable since its components do not wear out as fast as the components of the prior art rotary unions. At high temperatures small amounts of water can "weep" through the engaging surfaces of the silicon carbide components.

[0048] The improved rotary union 100 includes a first subassembly of components 110 fixedly and non-rotatably mounted to the inverted tub or shroud 73 which is attached to the mobile frame 52 of the roving sprayer and retrieval unit 50 and a second subassembly of components 150 rotatably mounted within the first subassembly 110. The first subassembly 110 provides a first silicon carbide seal surface 125 which is fixed, and the second subassembly 150 provides a second silicon carbide seal surface 165 which rotates at high speed and presses against the first silicon carbide seal surface 125 to create the more effective seal for water passing through the central bore of rotary union 100.

[0049] As shown in Figure 7, the first subassembly of components 110 comprises a fixed housing 130, which is mounted to the mobile frame 52 of the roving sprayer and retrieval unit 50, and a first floating silicon carbide seal member 120, which is non-rotatably, slidably mounted in cylindrical recess 115 in the housing 130 below the inlet 140 and above the recess 145. The housing 130 has an inlet 140 located at its upper portion for re-

ceiving the water that is to be sprayed by roving sprayer and retrieval unit 50 and has a recess 145 located at its lower portion for receiving the second subassembly of components 150.

[0050] Figure 7A shows an enlarged side view of the first floating silicon carbide seal member 120. The seal member 120 comprises an upside down T-shaped cylindrical support member 121, a silicon carbide component 124 affixed at the discharge end of member 121, an o-ring 128, an inlet end member which may be a flat washer 126, and a steel spring 127. Spring 127 biases washer 126, o-ring 128 and support member 121 downwardly so that surface 125 presses against surface 165 when installed as a unit. The T-shaped cylindrical member 121, o-ring 128 and washer 126 have a central inside bore 122. As best seen in Figures 7B and 7C, member 121 has at its lower end a pair of recesses 132 which engage a pair of lugs 133 in the housing 130 to permit slidable (floating) but non-rotational movement of member 121 in recess 115. (Alternatively, member 121 may be formed with a pair of lugs which fit into recesses in housing 130). T-shaped member 121 at its other end also has a raised lip 123 at its upper portion extending into the central bore 121 of o-ring 128 and supporting its inner surface. The silicon carbide component 124 is affixed to the bottom of the T-shaped cylindrical member 121 and provides the first silicon carbide seal surface 125, which faces downwardly. The o-ring 128 is placed on top of the raised lip 123 of the cylindrical member 121, and the inner bore of the o-ring 128 abuts the raised lip 123.

[0051] The flat washer 126 is placed on top of the o-ring 128. The flat washer 126 comprises a countersunk inner bore 129, which extends partially into the inner bore of the o-ring 128 and abuts and supports its inner surface. The o-ring 128, in effect, is sandwiched between the end of raised lip 123 of the cylindrical member 121, on its one hand, and the end of countersunk bore 129 of the flat washer 126, on the other hand. The vertical edges 131 of washer 126 slidably engage in the inner walls of recess 115 as shown in Fig. 7. This sandwiching feature prevents the o-ring 128 from being blown into the inner bore 122 of the cylindrical member 121 by the high pressure, high temperature water which is present at the interface between o-ring edges 131 and the outside diameter of member 121, on the one hand, and the walls of recess 115, on the other hand. This feature overcomes the problem with prior art rotary unions which have o-rings that are more easily blown into the inner bore by the high pressure or high temperature water. This sandwiching feature provides a novel way of retaining the o-ring 128 at its set location for proper operation of the rotary union. In this manner, o-ring 128 effectively seals the aforesaid interface and prevents high pressure water from bypassing the rotary union seal at surfaces 125, 165 by attempting to go around member 121 through the interface (slide fit) with recess 115 and cylindrical member 121.

[0052] Figure 8 shows the second subassembly of components 150. The second subassembly 150 comprises a rotating spindle or hollow shaft 170, a silicon carbide component 160, a roller bearing unit 180, a shaft collar 185, a spring clip retaining washer 190, and a sealing ring 195. The rotating spindle or hollow shaft 170 has a central bore 161 into which water that flows through the rotary union 100 is received. The silicon carbide component 160 is mounted at the top of the rotating spindle 170 to provide the second silicon carbide seal surface 165. In operation the second silicon carbide seal surface 165 is pressed and rotated against the first silicon carbide seal surface 125, to form an effective seal which prevents high pressure water passing through the rotary union 100 from leaking through the seal.

[0053] The sealing surfaces have been described in the preferred embodiment as being silicon carbide. The sealing surfaces may also be made of tungsten carbide or any other hard, durable material used as a sealing surface which is soft enough to effectively make a seal at the sealing surfaces yet is hard enough to give a long life to the sealing surfaces such as is provided by silicon carbide under the conditions in which the present invention is operated. Using silicon carbide sealing surfaces the lifetime of the sealing surfaces is in excess of 16,000 hours operating at 3000 psi, 250°F and 1500 rpm.

[0054] The roller bearing unit 180 is attached to the central portion of the rotating spindle 170, and this unit 180 provides rotating support to the rotating spindle 170. The shaft collar 185 is also attached to the upper portion of the rotating spindle 170 for holding and supporting the roller bearing unit 180 to the rotating spindle 170. The roller bearing unit 180 comprises a pair of roller bearing columns 182, bearing supports 181 attached to the shaft collar 185, and a bearing spacer 183 attached between the two bearing rings 182. one roller bearing ring is mounted on top of the other at the central portion of the spindle 170. The roller bearing rings 182 provide the rolling function for rotating the spindle 170, and the bearing supports 181 hold the roller bearing rings 182 in position on the rotating spindle 170. The bearing spacer 183 separates the two column's 182 so that these columns can rotate independently.

[0055] The spring clip retaining washer 190 is attached below the roller bearing unit 180, and this washer 190 retains the second subassembly of components 150 within the first subassembly of components 110. The washer 190 is retained within a recess 146 at the lower portion of the first subassembly 110 to hold the second subassembly 150 in the first subassembly 110.

[0056] The rotating spindle or hollow shaft 170, as seen in Figure 8 has a threaded portion 198 at its lower end for attaching and engaging the retrieval rotor 59. The rotating spindle or hollow shaft 170 used in the preferred embodiment is illustrated in Figure 11.

[0057] At the outer peripheral ends of two of the swept back rods 65 are affixed nozzles 55. The upward reaction force to the downward force component of high

pressure water exiting through nozzles 55 carried by retrieval rotor 59 causes the second subassembly of components 150 to move upwardly towards the first subassembly of components 110 pressing face 165 upwardly against the downward bias of spring 127 and into sealing contact with-face 125. During operation the second silicon carbide surface 165 rotates against the first silicon carbide surface 125, and a sealing relationship is established between the two surfaces for water passing through the rotary union 100 at high pressure and temperature without leaking through or around the rotary union seal. Operational pressure of 3000 psi at 250°F and 1500 rpm are readily achievable with the present invention.

[0058] A second embodiment, which is the preferred embodiment, of the roving sprayer and retrieval unit 250 is shown in Figures 12-14. The roving sprayer and retrieval unit 250 of this embodiment can be used either as a stand alone unit or in combination with the reclamation and recycling system 60. The roving and retrieval unit 250 can be used as a stand alone unit in a situation where there is a source of water and facilities to dispose of the unprocessed water that has been recovered by the unit 250. In the following description of the embodiment shown in Figure 12-14 parts that are identical to corresponding parts in the previously discussed embodiment will be referred to by the same reference number.

[0059] Figure 12, which is a top view of the roving sprayer and retrieval unit 250, includes a mobile frame 52 that is supported from the ground surface by four wheels 54. A handle 53 is secured to the mobile frame 52 which allows an operator to walk behind, control the water flow to and movement of the roving sprayer and retrieval unit 250. A shroud 73 having the shape of an inverted tub or shroud is secured to the under surface of the mobile frame 52. The discharge end of a flexible water transporting hose 51 is connected to the rotary union 100 through which pressurized water is directed to the water discharge jets 55. An internal combustion engine 56 or its equivalent, which could be a 12V electric motor, is mounted on the mobile frame 52. Engine 56, drives the retrieval rotor 59 through a shaft drive such as a belt 62 and sheave 69 (see Figure 11). The inverted tub or shroud 73 is provided with a pair of exit ducts 78 that are spaced 180 degrees from each other. Each exit duct 78 empties into a conduit 63 and both conduits 63 flow into tank 152 that is supported by the mobile frame 52. A positive displacement pump 154 is mounted on the mobile frame 52. Pumps of this type are much more efficient than a vacuum system for discharging the water and debris from the roving sprayer and retrieval unit 250. Pump 154 is in fluid communication with tank 152 through conduit 156. Water received by the pump 154 through conduit 156 is discharged through a conduit 261. If the roving sprayer and retrieval unit 250 is being used as a stand alone unit then the water is discharged through return conduit 261 to the sewage system or oth-

er disposal facility. The return conduit 261 could also discharge into the liquid storage component 20 from which it can be properly disposed of.

[0060] When the roving sprayer and retrieval unit 250 is being used in combination with the reclamation and recycling system 60, the water is returned through the return conduit 261 to the filtration tank 400. An advantage of this embodiment over the previous embodiment is that with this embodiment it is no longer necessary for the filtration tank to be maintained at a vacuum. The vacuum source 300, that is comprised of the pump 310, motor 320 and conduit 350, illustrated in Figure 9 can be eliminated. The baffles 433, located below trough 420, in Figure 9 can also be eliminated from the filtration tank 400 in this embodiment. The positive displacement water pumps 154 carried by the roving sprayer and retrieval units 250 are much more efficient than the vacuum system 300 of the previously described embodiment. Pump 154 is driven by a belt 155 and sheave 169. As seen in Figure 11 sheave 169 is secured to the rotating spindle or hollow shaft 170 of the rotary union 100. As previously discussed rotating spindle or hollow shaft 170 is driven by internal combustion engine 56 through a shaft drive such as a belt 62. Pump 154 could instead have its own power source, for example another internal combustion engine or a 12 Volt electric motor. The retrieval rotor 59 used with this embodiment is as shown in Figures 4-6 and 11.

[0061] The rotary union 100 used in this embodiment is as shown in Figures 7, 7A, 7B, 7C and 8 which has been previously discussed.

[0062] Figures 13 and 14 are cross section views of tank 152 taken along the lines 13-13 and 14-14 of Figure 12. Water and debris that has been recovered by the retrieval rotor 59 flows through conduits 63 and into the tank 152 through both tank end walls 157. A removable screen 158 is supported within tank 152 at a level below the entrance of conduits 63. Large debris is collected on the upper surface of screen 158 and the water passes through the screen. The screen 158 functions to remove any large debris such as nuts, bolts or nails that could damage the downstream pump 154. The tank 152 includes a sump 159 at one side from which the water is discharged through a conduit 156. As previously discussed conduit 156 is connected to the pump 154 which functions to discharge the water. The tank 152 includes a removable top 200 that provides access to the screen 158 and permits the screen 158 to be removed and cleaned. Top 200 includes an opening 151 through which the interior of tank 152 communicates with the ambient atmosphere. A baffle 149 extends at an upward angle into the opening 151 to prevent water from splashing out.

[0063] Another embodiment, Figure 15, is contemplated in which a plurality or series of roving sprayer and retrieval units 250, preferably of the type shown in Figures 12-14, are coupled together as a combined unit 178. This combined unit 178 can function either as a

stand alone unit or be towed behind a self propelled vehicle that could also function as the component carrying platform. The combined unit 178 could also be mounted on a forwardly extending hydraulically operated boom arm which would enable the operator of the self propelled vehicle to see and control the combined unit 178. The combined unit could also be carried by or under the self propelled vehicle in which case the combined unit 178 would be maneuvered along with the self propelled vehicle.

[0064] In the embodiment in which one end of the combined unit 178 is hitched to the self propelled component carrying platform a handle 153 is connected to the other end of the series. One operator drives the self propelled component carrying platform or vehicle 70 and a second operator controls the series of roving sprayers 250 through handle 153. In this embodiment the second operator can control the trailing end of the series of roving sprayer and retrieval units such that they extend at an angle to the direction of travel of the towing vehicle 70. In this embodiment the operator controlling the trailing end of the series can change the angle of the series of sprayers 250 relative to the direction of travel of the towing vehicle 70 such that the overlap of the sprayers 250 can be changed. When a portion of the surface being cleaned is encountered that is particularly dirty the overlap can be increased and the processing of this area of the surface will be multiplied. This of course reduces the swath but enables the surface to be cleaned uniformly with a single pass. Of course when an area of the surface is encountered that is particularly clean the overlap can be decreased and the swath increased. This embodiment has the advantage that fewer operators are required and adjustments can be made on the go for the condition of the particular area of surface being processed. The economy and the cleaning capacity of the system is greatly increased.

[0065] In the embodiment shown in Figure 15, a plurality of retrieval units 250 are hitched together to form a combined unit 178. There are four roving sprayer and retrieval units 250 hitched together in Figure 15, however it should be understood that there could be fewer or more units hitched as a unit 178. The hitch mechanism 177 that connects two units 250 comprises first 171 and second 172 longitudinally extending links that are connected by ball joints at each end to the mobile frames 52 of adjacent unit 250. A transverse link 173 is also connected, at its opposite ends, by ball joints to the mobile frames 52 of adjacent units 250. This hitch mechanism 177 allows relative movement between adjacent roving sprayer and retrieval units 250 while maintaining the series of units aligned longitudinally. The hitch mechanism 177 will allow, for example, one roving sprayer and retrieval unit to be moving up an inclined surface while the adjacent unit is moving down a declining surface. The hitch mechanism 177 will also permit one roving sprayer and retrieval unit 250 to rotate relative to the adjacent unit that it is hitched to about the lon-

gitudinal axis of the combined unit.

[0066] The combined unit 178 shown in Figure 15 is hitched at its front end hitch members 175 to a self propelled vehicle such as a truck by a ball type hitch that will allow the combined unit to swivel relative to the towing vehicle. A handle 153 is secured to the mobile frame 52 of the last roving sprayer and retrieval unit 250. An operator controls the combined unit 178 through the handle 153. In this embodiment a first operator who drives the towing vehicle and a second operator who controls the combined unit 178 can process considerably more surface area than when using a single roving sprayer and retrieval unit 250. The second operator can cause the combined unit 178 to extend along a line that is inclined to the direction of travel and thereby determine the swath that the combined unit will process in a pass of the device. The swath can be narrowed in areas where the debris is greater than in other areas. The first and second operators can communicate vocally through speakers and head sets and the driver of the towing vehicle can view the combined unit through a video system.

[0067] In the combined unit 178 shown in Figure 15 the waste return conduit 61 of the first two units are combined and the waste return conduit 61 of the last two units are combined. As a result only two waste return conduits 61 extend to the towing vehicle 70.

[0068] All of the above described embodiments can also be used as liquid pick up mechanisms, for processing flat surfaces that are covered with a liquid that was not deposited on the surface by the mechanism of this invention. An example of such a use is to clean up the deicing fluid that falls to the surface while an aircraft is being sprayed to protect against icing during inclement weather conditions. Deicing fluids such as ethylene glycol, methyl alcohol, ethyl alcohol are used in this process. These deicing fluids can be harmful to the environment particularly if they find their way into the rivers, streams and lakes. When the deicing fluids fall to the concrete surface on which the aircraft is resting it saturates the adjacent surface and collects in puddles. Some of this surface liquid can be retrieved by existing vacuum systems carried by trucks. However, the deicing fluids will within a relatively short time fill and flow through the cracks, crevices and expansion joints of the surface. Conventional vacuum surface cleaners are unable to retrieve the deicing fluids from the cracks, crevices and expansion joints. The deicing fluids in the cracks, crevices and expansion joints flow to the drainage canals and storm sewers from which it eventually find its way into our rivers, streams and lakes.

[0069] For the above reasons it is important that the deicing fluid be recovered as quickly as possible. The conventional vacuum pick up systems have a relatively narrow swath of about 8 feet and advance at a relatively slow rate. Each modular of this invention is supported relative to the underlying surface such that the brush seal extending along the peripheral edge engages the

surface. The brush seal concentrates the vacuum pick up of this invention to a relatively small area, however the vacuum is very strong and effective. A combined unit consisting of 8 to 12 modular units can be used to process a very wide swath, 20 to 30 feet, and quickly recover the deicing fluid before it has had the opportunity to flow into the storm sewers:

[0070] Although the recovered deicing fluid can be reclaimed, the process can not be economically performed at remote sites. Thus, the recovered deicing fluid must be collected and transported to stationary processing facilities. When using the invention as a liquid pick up mechanism the reclamation system of this invention is not utilized. The recovered deicing fluid can be collected for example in the liquid storage component 20, a stationary storage tank or a tank carried by a pickup truck or other vehicle. This invention can also be used to clean up other types of chemical spills to prevent pollution.

[0071] The foregoing description of a preferred embodiment and best mode of the invention known to applicant at the time of filing the application has been presented for the purposes of illustration and description. It is not intended to be exhaustive or to limit the invention to the precise form disclosed, and obviously many modifications and variations are possible in the light of the above teaching. The embodiment was chosen and described in order to best explain the principles of the invention and its practical application to thereby enable others skilled in the art to best utilize the invention in various embodiments and with various modifications as are suited to the particular use contemplated. It is intended that the scope of the invention be defined by the claims appended hereto.

Claims

1. A mobile system (10) for processing flat surfaces of the type including a liquid storage component (20), a retrieval unit (50) for retrieving liquid from the surface being processed, said retrieval unit (50) including a mobile frame (52), a shroud (73) carried by said mobile frame (52), said shroud (73) comprised of a generally disk-shaped top having a skirt extending downwardly from the periphery thereof and a shaft journaled in the central portion of said disk-shaped top **characterised by:**

a power drive (56) carried by said retrieval unit (50), a shaft drive (62) for imparting rotation, in a given direction, to said shaft (62) from said power drive (56);
a retrieval rotor (59) secured to said shaft (62) at a location below said disk-shaped top, said retrieval rotor (59) including a plurality of curved blades (66), said blades (66) being secured to and radiating from said shaft (62), said curved

blades (66) including substantially vertical curved surfaces (68) that are curved away from said given direction of rotation and terminate adjacent said skirt;
 at least one exit openings (78) formed in said skirt; and
 a conduit (63) extending from said exit opening (78) formed in said skirt to said liquid storage component (20).

2. The system as set forth in claim 1 wherein the system further consists of:

said liquid storage component (20) functions to hold water that is to be used for cleaning flat surfaces;
 a water pumping component (30) for pumping and pressurizing water from said liquid storage component (20);
 a reclamation system having an inlet and an outlet, said reclamation system receives water and matter, from the retrieval unit (50) through said inlet, said reclamation system separates the water from the matter and conveys cleaned water through said outlet into said liquid storage component (20) for reuse;
 said retrieval unit (50) functions as a water sprayer unit for spraying the pressurised water onto the surface being processed;
 said shaft being hollow;
 at least one water jet secured to said retrieval rotor (50);
 said conduit extends from said exit opening formed in said skirt to the inlet of said reclamation system and from the outlet of said reclamation system to said liquid storage component (20);
 a flexible water transporting hose extending from said water pumping component (30) to said water pumping component (30) and then to the interior of said hollow shaft; and
 conduits extending from the interior of said hollow shaft to said water jet through which water flows from the interior of said hollow shaft to said water jets and is sprayed on the surface to be cleaned.

3. The system as set forth in claim 1 or 2 wherein said retrieval rotor (50) includes stabilizers that extend between the tips of adjacent blades (66).

4. The system as set forth in claim 1 or 2 wherein the invention further includes:

a positive displacement pump carried by said carriage (70);
 a pump drive connecting said power drive to said positive displacement pump for driving

said positive displacement pump;
 a tank carried by said carriage (70);
 said conduit, extending from said exit opening formed in said skirt, empties into said tank and continues as an outlet for said tank; and
 said positive displacement pump functioning to pump the contents of said tank through said outlet conduit.

5. The system as set forth in claim 1 or 2 wherein said substantially vertical curved surfaces (68) of the blades (66) include a lip (67) extending in said given direction along the lower edge thereof.

6. The system as set forth in claim 1 or 2 wherein said downwardly extending skirt includes a substantially horizontal extending lip (75) extending from the lower edge (74) thereof toward the center of said shroud (73).

7. The system as set forth in claim 3 wherein said substantially vertical curved surfaces (68) of the blades (66) include a lip (67) extending in said given direction along the lower edge thereof.

8. The system as set forth in claim 3 wherein said downwardly extending skirt includes a substantially horizontal extending lip (75) extending from the lower edge (74) thereof toward the center of said shroud (73).

9. The system as set forth in claim 1 or 2 wherein a plurality of said retrieval units (50) are coupled together in the fore and aft direction to form a combined unit.

10. The system as set forth in claim 9 wherein the means for coupling together said retrieval units (50) in the fore and aft direction permits one retrieval unit (50) to move up an inclined surface while an adjacent unit is moving down a declining surface and to permit one retrieval unit (50) to rotate relative to the adjacent unit (50).

11. The system as set forth in claim 9 wherein said substantially vertical curved surfaces (68) of the blades (66) include a lip (67) extending in said given direction along the lower edge thereof.

12. The system as set forth in claim 9 wherein said downwardly extending skirt includes a substantially horizontal extending lip (75) extending from the lower edge (74) thereof toward the center of said shroud (73).

13. The system as set forth in claim 11 wherein said downwardly extending skirt includes a substantially horizontal extending lip (75) extending from the low-

er edge (74) thereof toward the center of said shroud (73).

14. The system as set forth in claim 9 wherein the invention further includes:

a self propelled unit;
said liquid storage component (20) carried by said self propelled unit; and
hitching means for connecting said combined unit to said self propelled unit.

15. The system as set forth in claim 1 or 2 wherein the invention further comprises:

a brush seal (85) secured to and extends downwardly from the free edge of said skirt; and said shroud (73) carried by said mobile frame (52) such that said brush seal (85) engages said flat surface being processed.

Patentansprüche

1. Mobiles System (10) zum Bearbeiten flacher Oberflächen des Typs umfassend eine Flüssigkeitsspeicherkomponente (20), eine Wiederaufnahmeeinheit (50), um Flüssigkeit von der gerade behandelten Oberfläche wieder aufzunehmen, wobei die Wiederaufnahmeeinheit (50) einen mobilen Rahmen (52), eine Abdeckung (73), die von dem mobilen Rahmen (52) getragen ist, umfasst, wobei die Abdeckung (73) von einem allgemein scheibenförmigen oberen Teil gebildet ist, das eine sich von dessen Umfang nach unten erstreckende Einfassung und eine im zentralen Abschnitt des scheibenförmigen oberen Teils gelagerte Welle aufweist, **gekennzeichnet durch**

einen Motorantrieb (56), der von der Wiederaufnahmeeinheit (50) getragen ist, einen Wellenantrieb (62), um die Welle (62) **durch** den Motorantrieb (56) in einer gegebenen Richtung in Drehung zu versetzen;

einen an der Welle (62) an einer Stelle unterhalb des scheibenförmigen oberen Teils befestigten Wiederaufnahmerotor (59), wobei der Wiederaufnahmerotor (59) eine Mehrzahl von gekrümmten Blättern (66) umfasst, wobei die Blätter (66) an der Welle (62) befestigt sind und von dieser strahlenförmig ausgehen, wobei die gekrümmten Blätter (66) im Wesentlichen vertikale gekrümmte Oberflächen (68) umfassen, die von der gegebenen Drehrichtung weg gekrümmt sind und der Einfassung benachbart enden;

wenigstens eine in der Einfassung ausgebildete Ausgangsöffnung (78); und

eine Leitung (63), die sich von der in der Einfassung ausgebildeten Ausgangsöffnung (78) zur

Flüssigkeitsspeicherkomponente (20) erstreckt.

2. System nach Anspruch 1, wobei das System ferner gebildet ist von:

der Flüssigkeitsspeicherkomponente (20), die die Funktion hat, Wasser zu fassen, das zum Reinigen flacher Oberflächen benutzt werden soll;
einer Wasserpumpkomponente (30), um Wasser von der Flüssigkeitsspeicherkomponente (20) zu pumpen und unter Druck zu setzen;
einem Wiedergewinnungssystem, das einen Einlass und einen Auslass aufweist, wobei das Wiedergewinnungssystem durch den Einlass Wasser und Materie von der Wiederaufnahmeeinheit (50) erhält, wobei das Wiedergewinnungssystem das Wasser von der Materie trennt und das gereinigte Wasser durch den Auslass zur Wiederverwendung in die Flüssigkeitsspeicherkomponente (20) fördert;
der Wiederaufnahmeeinheit (50), die die Funktion einer Wassersprüheinheit hat, um das unter Druck gesetzte Wasser auf die gerade behandelte Oberfläche zu sprühen;
der Welle, die hohl ist;
wenigstens einer Wasserstrahldüse, die an dem Wiederaufnahmerotor (50) befestigt ist;
der Leitung, die sich von der in der Einfassung gebildeten Ausgangsöffnung zum Einlass des Wiedergewinnungssystems und vom Auslass des Wiedergewinnungssystems zur Flüssigkeitsspeicherkomponente (20) erstreckt;
einem flexiblen Wassertransportschlauch, der sich von der Wasserpumpkomponente (30) zur Wasserpumpkomponente (30) und dann zum Inneren der hohlen Welle erstreckt; und
Leitungen, die sich vom Inneren der hohlen Welle zu der Wasserstrahldüse erstrecken, durch die Wasser vom Inneren der hohlen Welle zu den Wasserstrahldüsen fließt und auf die zu reinigende Oberfläche gesprüht wird.

3. System nach Anspruch 1 oder 2, wobei der Wiederaufnahmerotor (50) Stabilisatoren umfasst, die sich zwischen den Spitzen benachbarter Blätter (66) erstrecken.

4. System nach Anspruch 1 oder 2, wobei die Erfindung ferner umfasst:

eine Verdrängerpumpe, die vom Wagen (70) getragen ist;
einen Pumpenantrieb, der den Motorantrieb mit der Verdrängerpumpe verbindet, um die Verdrängerpumpe anzutreiben;
einen Tank, der von dem Wagen (70) getragen ist;

- die Leitung, die sich von der in der Einfassung gebildeten Ausgangsöffnung erstreckt und in den Tank mündet und sich als Auslass für den Tank fortsetzt; und
wobei die Verdrängerpumpe die Funktion hat, den Inhalt des Tanks durch die Auslassleitung zu pumpen.
- 5
5. System nach Anspruch 1 oder 2, wobei die im Wesentlichen vertikalen gekrümmten Oberflächen (68) der Blätter (66) eine Lippe (67) umfassen, die sich in der gegebenen Richtung entlang deren unterer Kante erstreckt.
- 10
6. System nach Anspruch 1 oder 2, wobei die sich nach unten erstreckende Einfassung eine im Wesentlichen horizontal verlaufende Lippe (75) umfasst, die sich von deren unterer Kante (74) in Richtung des Zentrums der Abdeckung (73) erstreckt.
- 15
7. System nach Anspruch 3, wobei die im Wesentlichen vertikalen gekrümmten Oberflächen (68) der Blätter (66) eine Lippe (67) umfassen, die sich in der gegebenen Richtung entlang deren unterer Kante erstreckt.
- 20
- 25
8. System nach Anspruch 3, wobei die sich nach unten erstreckende Einfassung eine im Wesentlichen horizontal verlaufende Lippe (75) umfasst, die sich von deren unterer Kante (74) in Richtung des Zentrums der Abdeckung (73) erstreckt.
- 30
9. System nach Anspruch 1 oder 2, wobei eine Mehrzahl von Wiederaufnahmeeinheiten (50) in der Vorwärts- und Rückwärtsrichtung zusammengeklappt sind, um eine kombinierte Einheit zu bilden.
- 35
10. System nach Anspruch 9, wobei die Mittel zum Zusammenkoppeln der Wiederaufnahmeeinheiten (50) in der Vorwärts- und Rückwärtsrichtung es einer Wiederaufnahmeeinheit (50) ermöglichen, sich an einer nach oben geneigten Oberfläche nach oben zu bewegen, während sich eine benachbarte Einheit an einer nach unten geneigten Oberfläche nach unten bewegt, und es einer Wiederaufnahmeeinheit (50) ermöglichen, sich relativ zu der benachbarten Einheit (50) zu drehen.
- 40
- 45
11. System nach Anspruch 9, wobei die im Wesentlichen vertikalen gekrümmten Oberflächen (68) der Blätter (66) eine Lippe (67) umfassen, die sich in der gegebenen Richtung entlang deren unterer Kante erstreckt.
- 50
12. System nach Anspruch 9, wobei die sich nach unten erstreckende Einfassung eine im Wesentlichen horizontal verlaufende Lippe (75) umfasst, die sich von deren unterer Kante (74) in Richtung des Zentrums der Abdeckung (73) erstreckt.
- 55
13. System nach Anspruch 11, wobei die sich nach unten erstreckende Einfassung eine im Wesentlichen horizontal verlaufende Lippe (75) umfasst, die sich von deren unterer Kante (74) in Richtung des Zentrums der Abdeckung (73) erstreckt.
14. System nach Anspruch 9, wobei die Erfindung ferner umfasst:
- eine Selbstvortriebseinheit;
die Flüssigkeitsspeichereinheit (20), die von der Selbstvortriebseinheit getragen ist; und
Verbindungsmitel zum Verbinden der kombinierten Einheit mit der Selbstvortriebseinheit.
15. System nach Anspruch 1 oder 2, wobei die Erfindung ferner umfasst:
- eine Bürstendichtung (85), die an der freien Kante der Einfassung befestigt ist und sich von dieser nach unten erstreckt; und
die Abdeckung (73), die von dem mobilen Rahmen (52) derart getragen ist, dass die Bürstendichtung (85) mit der gerade behandelten flachen Oberfläche im Eingriff steht.

Revendications

1. Système mobile (10) destiné à traiter des surfaces plates du type comprenant un composant de stockage de liquide (20), une unité de récupération (50) destinée à récupérer le liquide provenant de la surface traitée, ladite unité de récupération (50) comprenant un châssis mobile (52), une enveloppe de protection (73) portée par ledit châssis mobile (52), ladite enveloppe de protection (73) étant composée d'une partie supérieure globalement en forme de disque ayant une collerette s'étendant vers le bas depuis sa périphérie et un arbre porté dans la partie centrale de ladite partie supérieure en forme de disque,

caractérisé par :

- une commande mécanique (56) portée par ladite unité de récupération (50), une commande, d'arbre (62) pour transmettre la rotation, dans une direction donnée, audit arbre (62) depuis ladite commande mécanique (56) ;
un rotor de récupération (59) fixé audit arbre (62) à un emplacement situé sous ladite partie supérieure en forme de disque, ledit rotor de récupération (59) comprenant une pluralité de pales courbées (66), lesdites pales (66) étant fixées audit arbre (62) et émanant de celui-ci, lesdites pales courbées (66) comprenant des

surfaces courbées sensiblement verticales (68) qui sont courbées en s'éloignant de ladite direction de rotation donnée et se terminent de manière adjacente à ladite collerette ;
 au moins une ouverture de sortie (78) formée dans ladite collerette ; et
 un conduit (63) s'étendant depuis ladite ouverture de sortie (78) formée dans ladite collerette vers ledit composant de stockage de liquide (20).

2. Système selon la revendication 1, dans lequel le système est en outre constitué par :

ledit composant de stockage de liquide (20) qui fonctionne pour contenir l'eau qui doit être utilisée pour nettoyer les surfaces plates ;
 un composant de pompage d'eau (30) pour pomper et mettre sous pression l'eau provenant dudit composant de stockage de liquide (20) ;
 un système de remploi ayant une entrée et une sortie, ledit système de remploi reçoit de l'eau et des matières, provenant de l'unité de récupération (50) par le biais de ladite entrée, ledit système de remploi sépare l'eau des matières et achemine l'eau nettoyée par le biais de ladite sortie dans ledit composant de stockage de liquide (20) pour une réutilisation ;
 ladite unité de récupération (50) qui fonctionne comme une unité de pulvérisation d'eau destinée à pulvériser l'eau mise sous pression sur la surface traitée ;
 ledit arbre étant creux ;
 au moins un jet d'eau fixé audit rotor de récupération (50) ;
 ledit conduit qui s'étend depuis ladite ouverture de sortie formée dans ladite collerette vers l'entrée dudit système de remploi et depuis la sortie dudit système de remploi vers ledit composant de stockage de liquide (20) ;
 un tuyau flexible d'acheminement d'eau s'étendant depuis ledit composant de pompage d'eau (30) vers ledit composant de pompage d'eau (30) puis vers l'intérieur dudit arbre creux ; et
 des conduites s'étendant depuis l'intérieur dudit arbre creux vers ledit jet d'eau à travers lequel l'eau s'écoule depuis l'intérieur dudit arbre creux vers lesdits jets d'eau et est pulvérisée sur la surface à nettoyer.

3. Système selon la revendication 1 ou 2, dans lequel ledit rotor de récupération (59) comprend des stabilisateurs qui s'étendent entre les pointas des pales adjacentes (66).
 4. Système selon la revendication 1 ou 2, dans lequel le système comprend en outre :

une pompe volumétrique portée par ledit chariot (70) ;
 une commande de pompe raccordant ladite commande mécanique à ladite pompe volumétrique pour commander ladite pompe volumétrique ;
 un réservoir porté par ledit chariot (70) ;
 ledit conduit, s'étendant depuis ladite ouverture de sortie formée dans ladite collerette, qui se jette dans ledit réservoir et continue en tant que sortie pour ledit réservoir ; et
 ladite pompe volumétrique fonctionnant pour pomper le contenu dudit réservoir par le biais dudit conduit de sortie.

5. Système selon la revendication 1 ou 2, dans lequel, lesdites surfaces courbées sensiblement verticales (68) des pales (66) comprennent un rebord (67) s'étendant dans ladite direction donnée le long de leur bord inférieur.
 6. Système selon la revendication 1 ou 2, dans lequel ladite collerette s'étendant vers le bas comprend un rebord s'étendant de manière sensiblement horizontale (75) s'étendant depuis son bord inférieur (74) vers le centre de ladite enveloppe de protection (73).
 7. Système selon la revendication 3, dans lequel lesdites surfaces courbées sensiblement verticales (68) des pales (66) comprennent un rebord (67) s'étendant dans ladite direction donnée le long de leur bord inférieur.
 8. Système selon la revendication 3, dans lequel ladite collerette s'étendant vers le bas comprend un rebord s'étendant de manière sensiblement horizontale (75) s'étendant depuis son bord inférieur (74) vers le centre de ladite enveloppe de protection (73).
 9. Système selon la revendication 1 ou 2, dans lequel une pluralité desdites unités de récupération (50) sont couplées ensemble dans la direction longitudinale pour former une unité combinée.
 10. Système selon la revendication 9, dans lequel le moyen destiné à coupler ensemble lesdites unités de récupération (50) dans la direction longitudinale permet à une unité de récupération (50) de monter le long d'une surface inclinée tandis qu'une unité adjacente descend le long d'une surface déclinante et permet à une unité de récupération (50) de tourner par rapport à l'unité adjacente (50).
 11. Système selon la revendication 9, dans lequel lesdites surfaces courbées sensiblement verticales (68) des pales (66) comprennent un rebord (67)

s'étendant dans ladite direction donnée le long de leur bord inférieur.

12. Système selon la revendication 9, dans lequel ladite collerette s'étendant vers le bas comprend un rebord s'étendant de manière sensiblement horizontale (75) s'étendant depuis son bord inférieur (74) vers le centre de ladite enveloppe de protection (73). 5
10
13. Système selon la revendication 11, dans lequel ladite collerette s'étendant vers le bas comprend un rebord s'étendant de manière sensiblement horizontale (75) s'étendant depuis son bord inférieur (74) vers le centre de ladite enveloppe de protection (73). 15
14. Système selon la revendication 9, qui comprend en outre : 20
une unité automotrice ;
ledit composant de stockage de liquide (20) porté par ladite unité automotrice ; et
un moyen d'accrochage pour raccorder ladite unité combinée à ladite unité automotrice. 25
15. Système selon la revendication 1 ou 2, dans lequel le système comprend en outre : 30
un joint en brosse (85) fixé au bord libre de ladite collerette et s'étendant vers le bas depuis celui-ci ; et
ladite enveloppe de protection (73) portée par ledit châssis mobile (52) de sorte que ledit joint en brosse (85) engage ladite surface plate traitée. 35

40

45

50

55

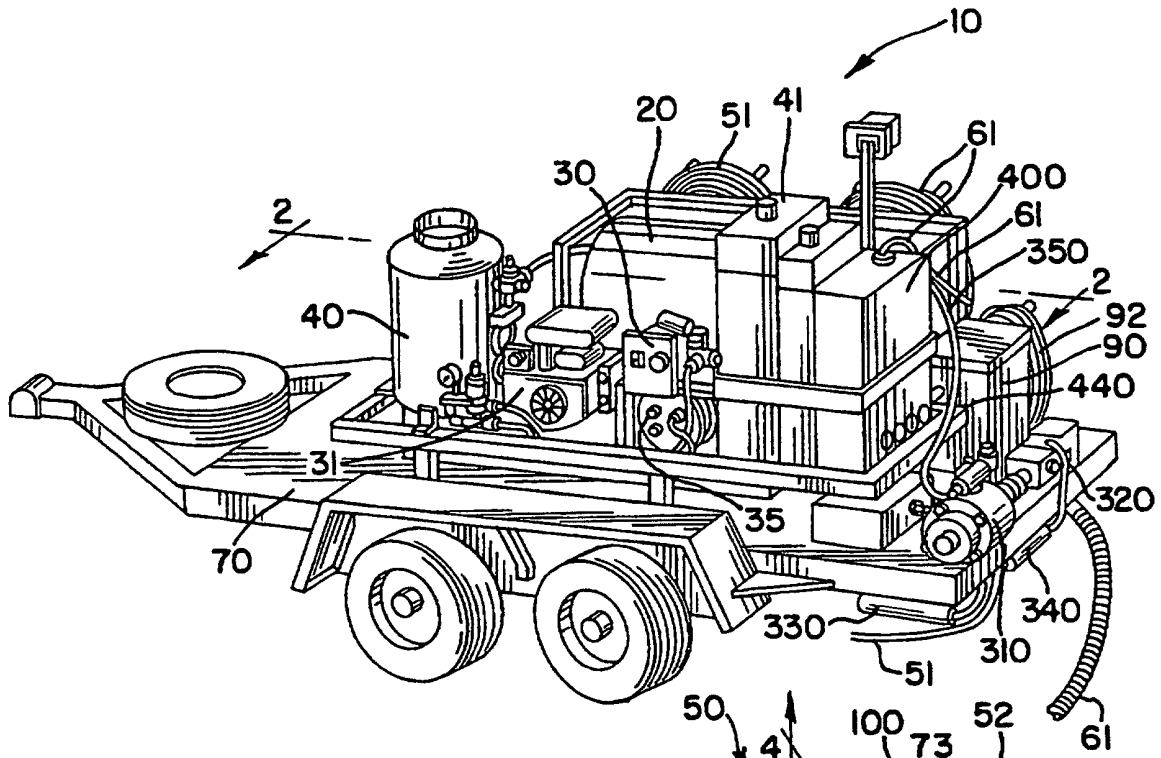

FIG. 1

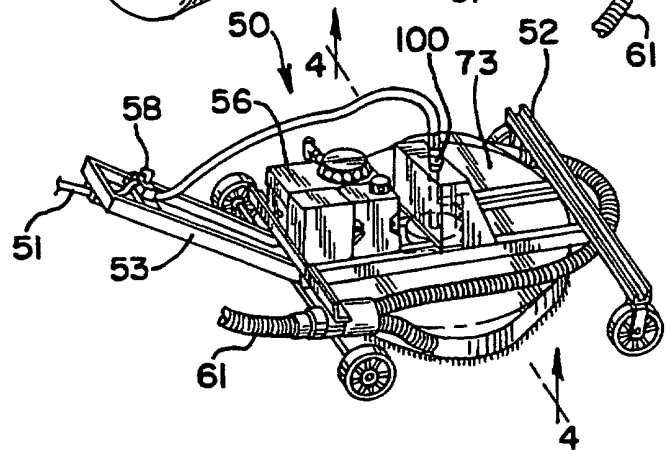
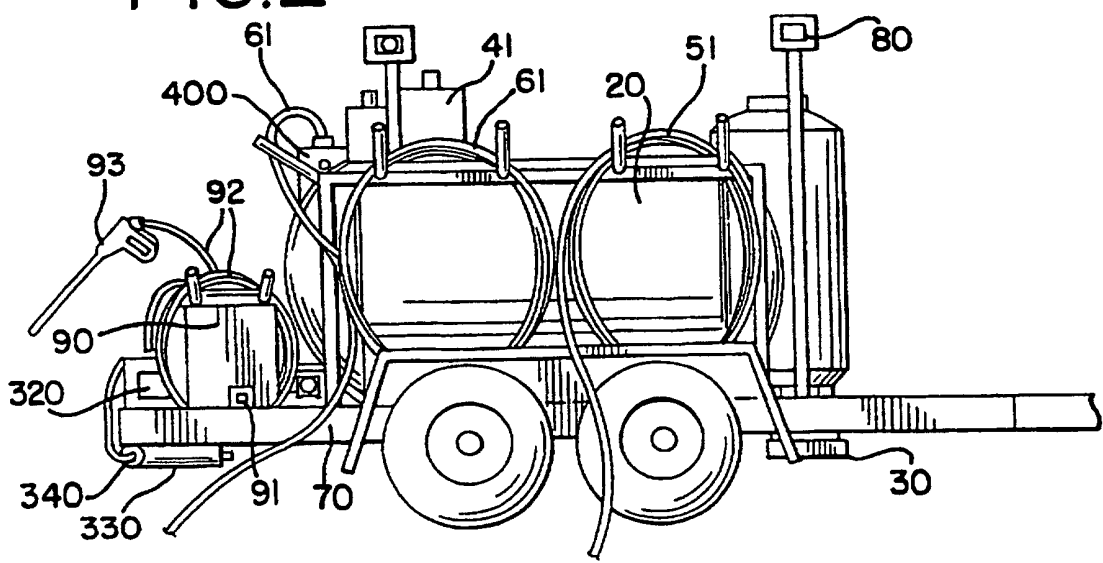

FIG. 2



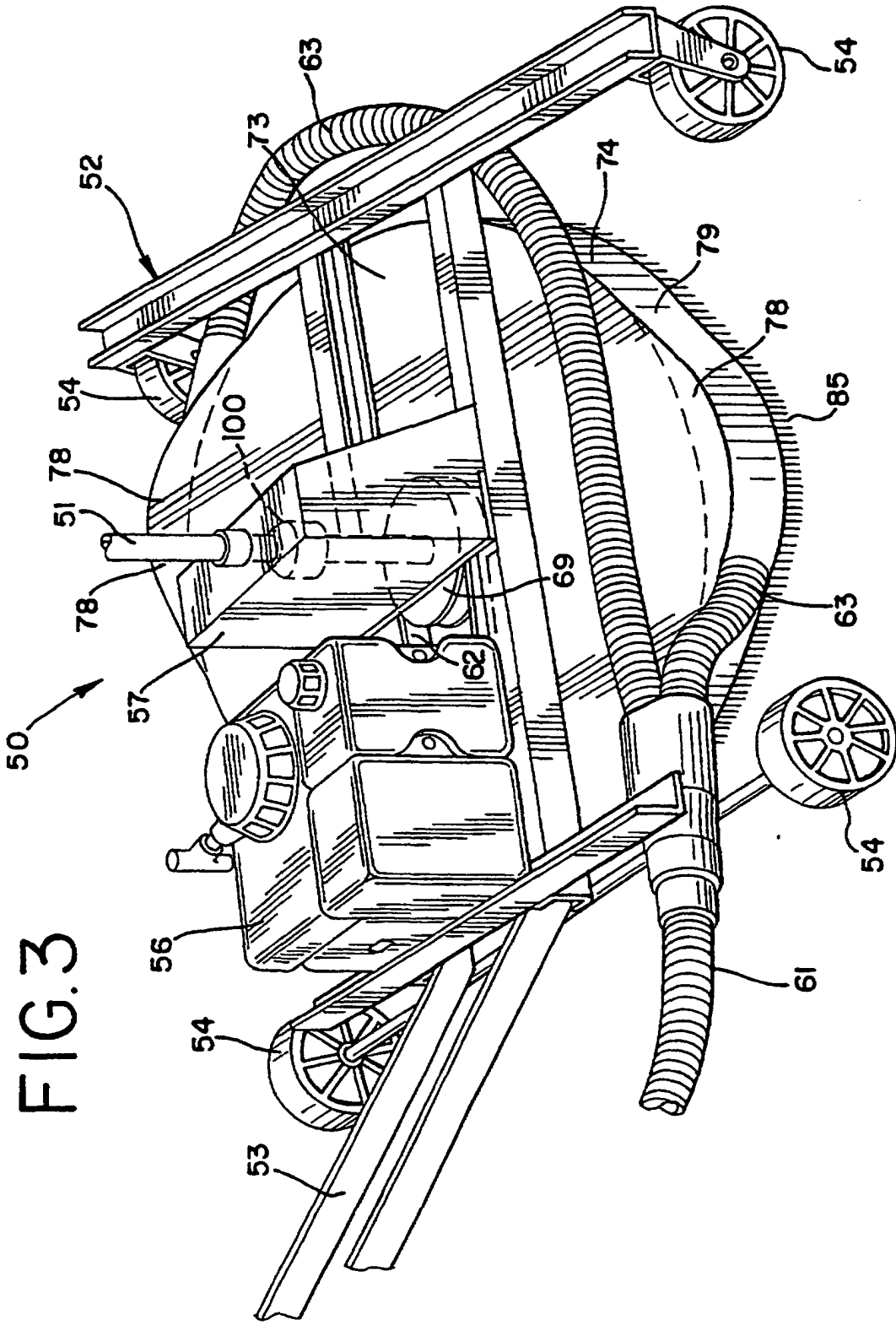

FIG. 7

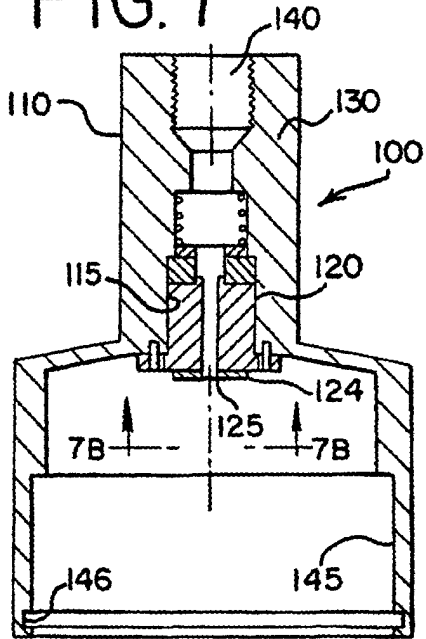

FIG. 7A

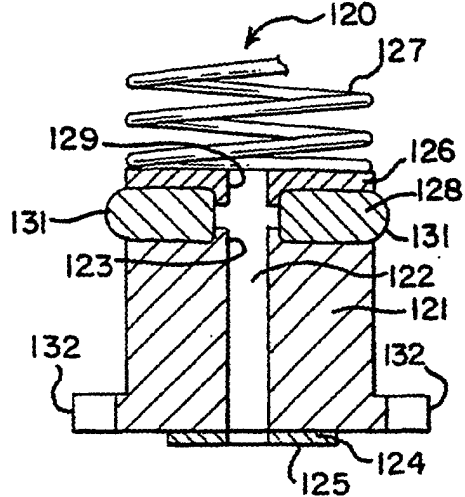

FIG. 7B

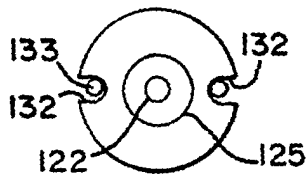

FIG. 8

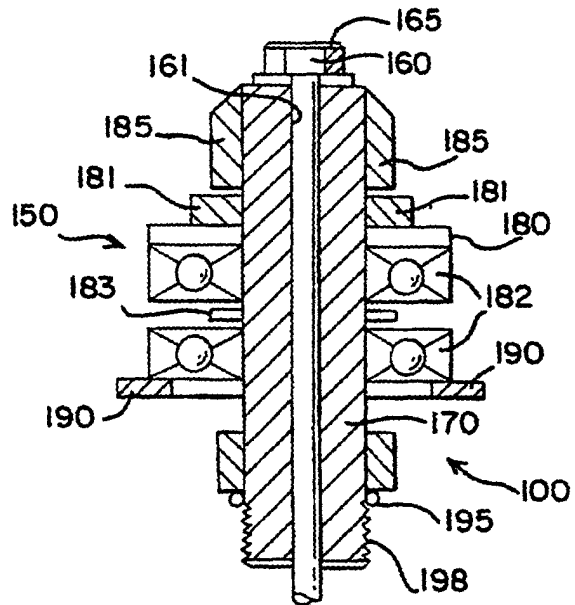
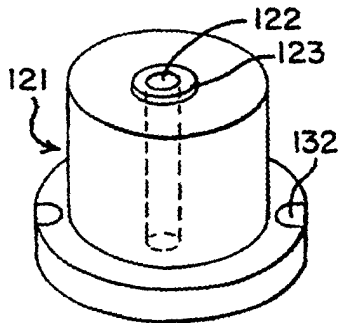
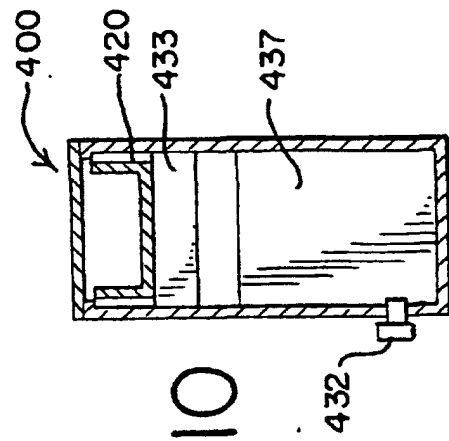
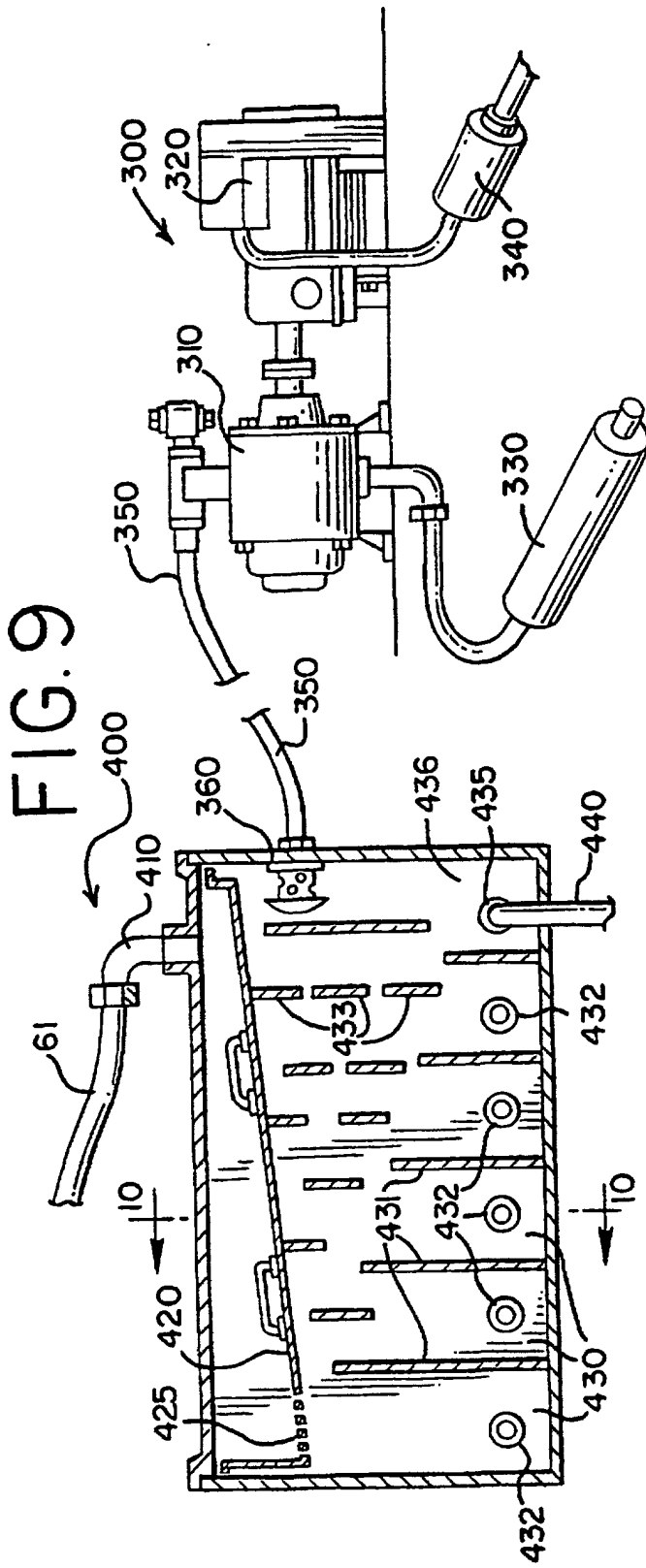
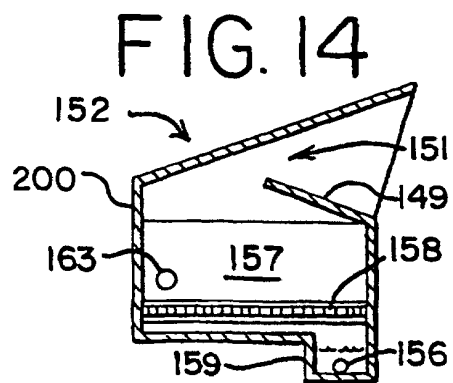
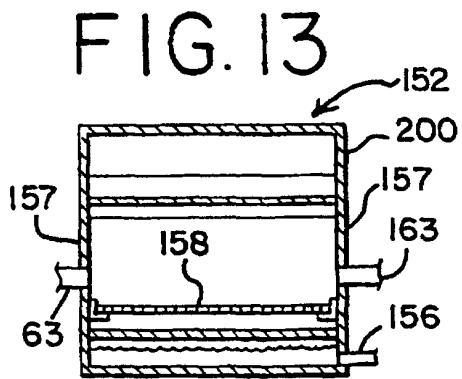
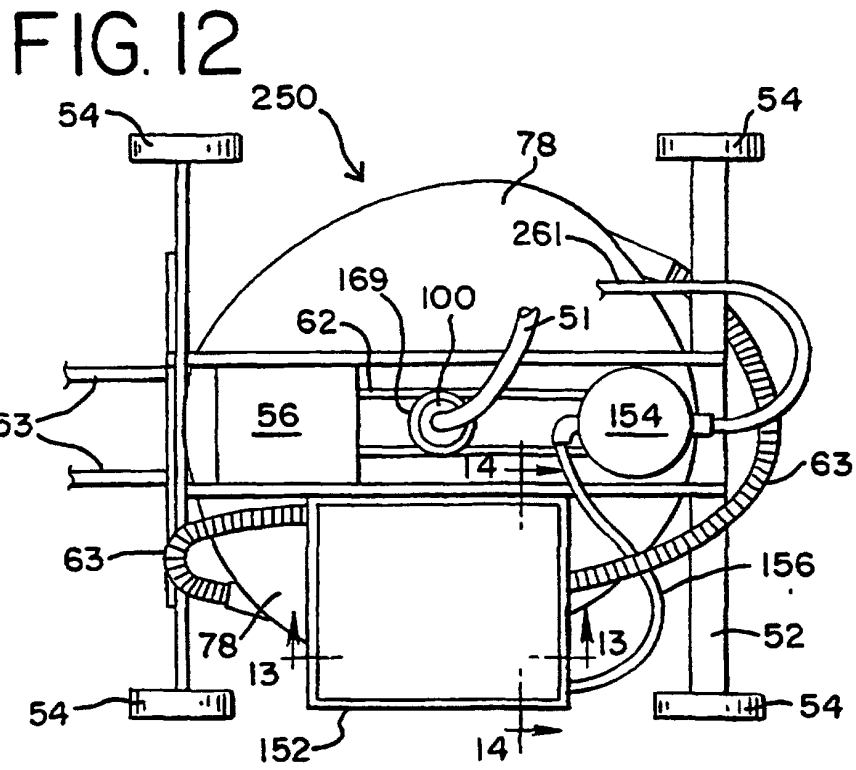
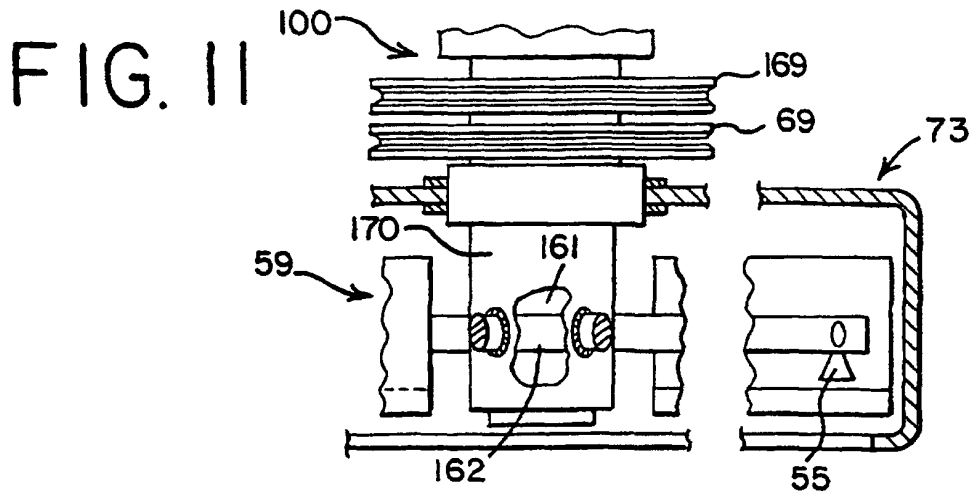

FIG. 7C







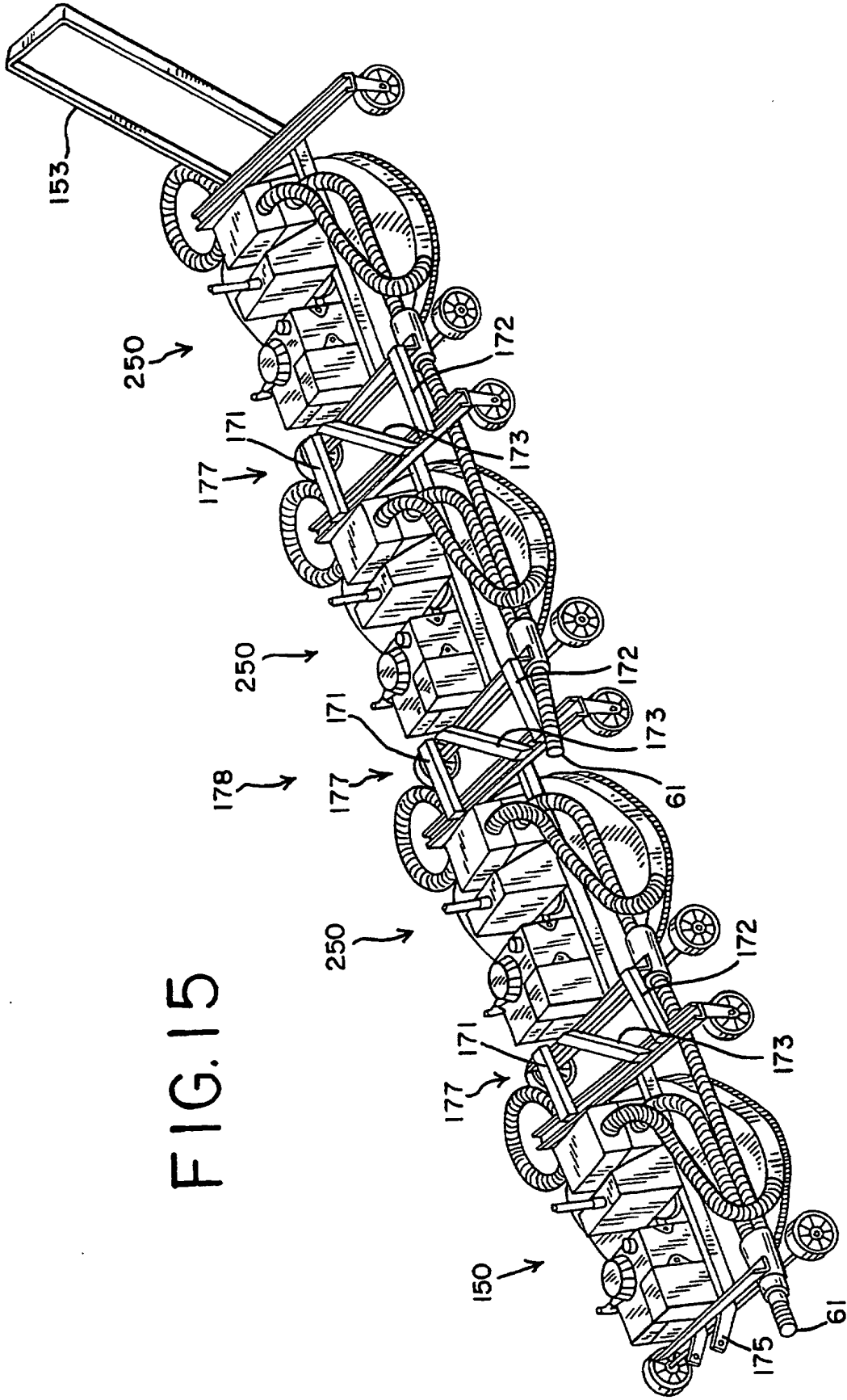

FIG.15