

(19) **DANMARK**

(10)

DK 181150 B1



(12)

PATENTSKRIFT

Patent- og
Varemærkestyrelsen

-
- (51) Int.Cl.: **H01M 8/0202 (2016.01)** **F16J 15/02 (2006.01)**
- (21) Ansøgningsnummer: **PA 2021 00560**
- (22) Indleveringsdato: **2021-05-27**
- (24) Løbedag: **2021-05-27**
- (41) Alm. tilgængelig: **2022-11-28**
- (45) Patentets meddelelse bkg. og publiceret den: **2023-03-01**
- (73) Patenthaver:
Blue World Technologies Holding ApS, Langerak 15A, 9220 Aalborg Øst, Danmark
- (72) Opfinder:
Mads Bang, Hanesvinget 1, 9520 Skørping, Danmark
Jakob Bork, Høje Støvring 40, 9530 Støvring, Danmark
Peter Leander Jensen, Midgården 121, 9230 Svenstrup J, Danmark
- (54) Titel: **Fuel cell stack, assembly of a bipolar plate and a gasket, and method of providing a sealing around a bipolar plate**
- (56) Fremdragne publikationer:
US 2003/0215692 A1
WO 00/54352 A1
WO 2015/060517 A1
US 2010/0143817 A1
EP 3246975 A1
- (57) Sammendrag:
For a fuel cell stack assemblies are provided of bipolar plates (2), BPPs, in combination with gaskets (3) that abut and cover the edge region (5) of each BPP for protecting the edge (5) of the corresponding BPP (2) and for electrically and thermally insulating the BPP (2). Advantageously, the gasket (3) is made of a resiliently stretchable material and pre-stressed by elongation to snug-fit around the edge (5) of the BPP (2) and for being held in place by resilient contraction of the gasket (3) around the perimeter.

Fortsættes...

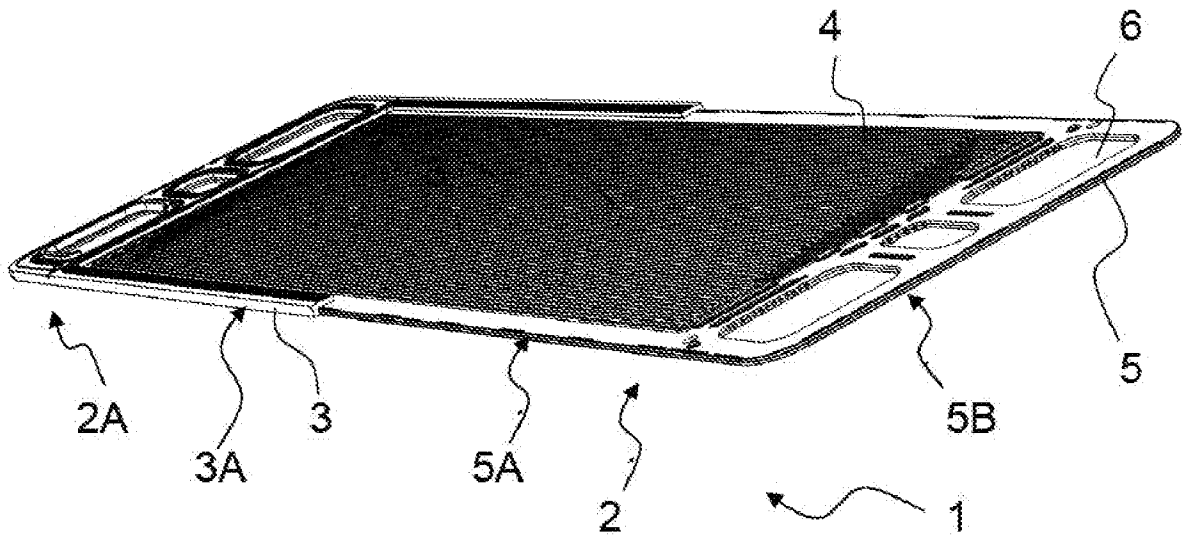

FIG. 1A

5 **Field of the Invention**

The present invention relates to a gasket on a bipolar plate for a fuel cell. In particular the invention relates to a fuel cell stack, an assembly of a bipolar plate and a gasket, and method of providing a sealing around a bipolar plate according to preambles of the independent claims.

10

Background of the invention

15 Polymer gaskets are generally used for sealing between the anode and cathode plates, especially bipolar plates (BPP). Not only is precise positioning necessary during production but it must also be ensured that gaskets stay in place for long term sealing. The latter is a challenge because repeated thermal cycling of the fuel cell tend to lead to expansion and contraction of the gaskets relatively to the bipolar plates, and may end with a significant movement and deformation of the gaskets to an extent that leads to leaks.

20

Various examples of combinations of electrode plates and gaskets where protrusions or grooves are used for keeping the gaskets in place are disclosed in International patent application WO2009/010066, US patent applications US2007/298310, US2012/164560, and US2014/0120452, German patent publications DE102014104015, DE102005046461 and DE102006054849 as well as German utility model DE202017103257.

25

30 US7081316 by Rock discloses a fuel cell with a bipolar plate being sandwiched between two gaskets that are located on the bipolar plate in a groove close to the rim of the bipolar plate. The gaskets comprise openings near opposite edges for channels that are required for transport of fuel gas and air along the stack. The bipolar plate assembly is made of metal plates that are bonded such that there are provided water channels in between the plates for cooling.

35

Patent applications US2005/079400 by Sugiura and US2002/0122970 by Inoue disclose moulding gaskets onto bipolar assemblies. However, this is a complicated and expensive solution, although it may provide good long term sealing. Patent US8865362 by Korsgaard, assigned to Serenergy A/S discloses a groove in which a gasket is laid down in order to fix the gasket. International patent application WO2013/069888 in Korean discloses a fuel cell assembly in which gaskets are provided with protrusions along edge regions which fit onto respective grooves.

Providing long-term stability of gaskets also puts challenges on the production, as the gaskets have to be moulded onto the plates or positioned precisely. It would be desirable to provide further improvement with respect to long term stability of gaskets on bipolar plates as well as ease of assembly during production.

Description of the invention

It is an objective of the invention to provide an improvement in the art. In particular, it is an objective to provide an improved gasket on a bipolar plate, BPP, as well as an improved production method. This objective is achieved by a fuel cell stack, by an assembly of a BPP and gasket, and by a method of providing a sealing around a bipolar plate, as set forth in the independent claims and in the following.

The assembly comprises a BPP and a gasket for the BPP. Typically, multiple of such assemblies are stacked to form part of a fuel cell stack with ion exchange membranes between adjacent BPPs, especially proton conducting membranes.

For example, the BPP is provided with an anode side and a cathode side that are integrally provided as part of a bipolar plate for a fuel cell stack. Alternatively, an anode plate and a cathode plate are combined into a bipolar plate by attaching the plates to each other back-to-back, for example by gluing or welding, with a

sealed coolant flow-field in between. Examples of such cooling flow-fields are channels, for example meander-formed channels.

5 For the BPP, various materials and production methods are possible. For example, metal plates, such as steel plates, are pressed into the correct shape with the protrusions by a corresponding press. Alternatively, the used plates are made by milling or molding. Examples of materials in the latter case are graphite, graphite-containing polymers, ceramics, metals and metallic alloys.

10 For each BPP a sealing non-conductive polymer gasket is provided so that one gasket is positioned between each two adjacent BPPs for sealing the volume between the membrane and its adjacent BPP by the gasket.

15 Each BPP has an edge region along an outer perimeter of the BPP. The gasket is abutting and covering this edge region and extends along and around the perimeter of the BPP for protecting the edge of the corresponding BPP and for insulating the BPP thermally as well as electrically. In some practical embodiments, the gasket extends around the perimeter of only one of the plurality of BPPs such that, for covering the edges of all BPPs, an equal number of gaskets are provided as BPPs.

20 In some embodiments, the fuel cell is of the type that operates at a high temperature. The term "high temperature" is a commonly used and understood term in the technical field of fuel cells and refers to operation temperatures above 120°C in contrast to low temperature fuel cells operating at lower temperatures, for example at 70°C. Optionally, the fuel cell operates in the temperature range of 120-200°C. The gasket is correspondingly made of a polymer material that is resistant to such temperatures.

30 The gasket is made of a deformable, advantageously resilient, polymer in order to deform the polymer by pressure during assembly of the stack into a secure sealing condition between the BPPs.

35 For example, the gasket is made of fluoropolymer. Examples are fluorinated ethylene propylene (FEP), polytetrafluoroethylene (PTFE), or perfluoroalkoxy

polymer (PFA). Fluoropolymers provide a high degree of long term stability even when made very thin.

5 Advantageously, the gasket is made of a resiliently stretchable material, for example elastomeric polymer. Especially useful are fluorinated elastomers, for example fluorinated carbon-based synthetic rubber, including fluoro-elastomers FKM and perfluoro-elastomers FFKM, or fluorinated silicones.

10 For example, in order to provide a tight connection to the BPP, the gasket is provided with an inner perimeter that is smaller than the outer perimeter of the BPP so that the gasket has to be pre-stressed by elongation before it snug-fits around the edge of the BPP. By resilient contraction of the gasket around the perimeter, the gasket is held in place on the edge of the BPP. For example, the inner perimeter of the gasket is 1-5% shorter than the outer perimeter of the
15 BPP.

Typically, the stack comprises a canal extending from one end to the opposite end of the stack for flow of gas or coolant through the canal. In practice, a plurality of such canals are provided for coolant and for the gases that are used
20 in the reaction. In the stack, such canal is formed by stacked canal segments, wherein each canal segment is provided as an opening extending through a corresponding BPP. Such opening has a rim delimiting the inner volume of the canal segment.

25 In some embodiments, for fixating two adjacent BPP relatively to each other, the gasket extends around the perimeter of one BPP, for example around the perimeter of only one of the plurality of BPPs, and into a canal section of an adjacent BPP, where the gasket is abutting at least a portion of the rim of the corresponding canal section of the adjacent BPP. As the gaskets is abutting the
30 outer periphery of one BPP and the inner periphery of a canal of an adjacent BPP, the two adjacent BPPs are locked laterally to each other, securing a proper position in the stack. By consequently locking each two subsequent BPPs to each other in this way, the BPPs of the entire stack are locked into fixed positions defined by the plurality of gaskets.

35

In practical embodiments, the gaskets of adjacent BPPs in the stack are abutting each other tightly and form an outer seal along the stack.

5 Due to the fact that the gaskets are surrounding the BPPs of the stack, the stack is electrically insulated relatively to the surroundings. Optionally, for nevertheless measuring the electrical potential of the various BPPs for diagnosis, each gasket comprises a probe-opening for receiving an electrical probe. The probe-opening extends from an outer side of the gasket through the gasket and to a BPP for measuring the voltage of the PBB by the probe. For example, the probe-opening 10 of a gasket extends to a BPP that is adjacent to the BPP that is surrounded by the gasket along its perimeter.

In order to prevent leakage through the probe-opening, the gasket provides a sealing between the probe-opening and the gas flow fields. Optionally, the gasket 15 comprises ribs that tightly abut the BPP between the probe-opening and the flow field, and/or the BPP comprises protrusions that sealingly abuts the gasket.

In some generally advantageous embodiments, the gasket comprises a rib or a plurality of ribs, against a first side of the BPP, and the BPP comprises a 20 protrusion, or a plurality of protrusions, on the first side, wherein the rib and the protrusion are arranged side by side and parallel to the perimeter. The rib is provided at a larger distance from the perimeter than the protrusion in order for the protrusion to block the rib from passing the protrusion towards the perimeter and for preventing the gasket to slide outwards in a direction away from the 25 perimeter.

Such protrusions are advantageously provided prior to combining the anode plate and cathode plate into a BPP, for example by impression into the material by a 30 tool acting on one side of the such plate, which results in forming a protrusion on the opposite side. This way, before combination into a BPP, both the cathode plate and the anode plate can be provided with protrusions, so that the BPP finally has protrusions on both sides.

Optionally, the gasket has a first portion that fits along and around the perimeter 35 of only one BPP and a second portion that extends in between two adjacent

BPPs. Advantageously, the second portion comprises ribs on opposite sides for being blocked from escaping by protrusions from both of two adjacent BPPs. For example, the two portions form a first and a second leg of an L-shaped gasket when viewed in a cross section that is provided as a cut through the gasket material perpendicular to the edge. For sealing purposes, the gasket advantageously extends in between two adjacent BPPs, encircling the canal section for sealing the canal section.

As mentioned, typically, the BPP comprising a flow pattern on either side of the BPP for flow of hydrogen on one side and flow of oxygen on the opposite side. Advantageously, each gasket extends sealingly around one of the flow patterns of a BPP for preventing escape of gas along the perimeter. The membrane may seal the flow pattern of the adjacent BPP. Optionally, the membrane is optionally provided between the gasket and a BPP so that each gasket abuts the surface of a BPP directly with one of its side and abut a membrane with the opposite side.

Prior to being mounted into a stack, the bipolar plates are optionally provided as single assemblies of a bipolar plate and a gasket, where the gasket is positioned on the BPP, for example by stretching as explained above, so that it is abutting and covering the edge and extends along the perimeter of the BPP for protecting the edge. Each of such single assemblies can then be transported safely to the location where a selected number of such BPP/gasket assemblies are combined into a fuel cell stack with a desired number of BPP/gasket combinations.

For example, the fuel cell in the fuel cell system is a high temperature polymer electrolyte membrane fuel cell, (HT-PEM), which operates above 120 degrees centigrade, differentiating HT-PEM fuel cell from low temperature PEM fuel cells, the latter operating at temperatures below 100 degrees, for example at 70 degrees. The normal operating temperature of HT-PEM fuel cells is the range of 120 to 200 degrees centigrade, for example in the range of 160 to 170 degrees centigrade. The polymer electrolyte membrane PEM in the HT-PEM fuel cell is mineral acid based, typically a polymer film, for example polybenzimidazole doped with phosphoric acid. HT-PEM fuel cells are advantageous in being tolerant to relatively high CO concentration and are therefore not requiring PrOx reactors between the reformer and the fuel cell stack, why simple, lightweight and

inexpensive reformers can be used, which minimizes the overall size and weight of the system in line with the purpose of providing compact fuel cell systems, for example for automobile industry.

5

Short description of the drawing

The invention will be described in the following with reference to the drawing, in which

FIG. 1A illustrates an assembly of a BPP and a gasket;

10

FIG. 1B illustrates shows an enlarged corner area of FIG. 1;

FIG. 2A shows extension of the gasket into a canal;

FIG. 2B shows the canal of FIG. 2A from the opposite side;

FIG. 3 is a close-up illustration of a cross section of the gaskets;

FIG. 4 shows a probe-passage in the gasket;

15

FIG. 5 show an open view of the probe-passage;

FIG. 6 illustrates the ribs of the gasket and the protrusions of the BPP;

FIG. 7 shows details of the BPP.

Detailed description

20

FIG. 1A illustrates an assembly 1 of a bipolar plate 2, BPP, and a gasket 3, of which only half is shown for illustrative reasons. In practice, the gasket 3 extends entirely around the BPP 2 along the edge 5 of the BPP 2. The gasket 3 has multiple functions, including

- 25
- shock resistance,
 - protection of the edges of the BPPs during assembly,
 - electrical insulation,
 - thermal insulation,
 - ease of positioning of the BPPs relatively to each other during stacking,
 - maintaining positions of the BPPs relatively to each other,
30 - prevention of detachment or gradual movement of the gasket which may cause leaks,
 - giving access to the BPPs by electrical probes despite gas tightness.

35

Advantageously, the gasket 3 is manufactured slightly shorter than the length of the perimeter around the BPP so that the gasket 3 has to be stretched to snug-fit

around the edge 5. This makes assembly easy, and the gasket 3 holds itself in place on the BPP 2.

5 For example, the circumference of the BPP is 1-5% longer than the length along the perimeter of the gasket. Typically, the BPP is rectangular, and so is the gasket with two first gasket parts and two second gasket parts which in combination are forming the rectangle, where the first part is longer than the second part. Optionally, the long edge 5A of the BPP is 1.5% longer than the corresponding long part 3A of the gasket 3, so that the gasket 3 for mounting is
10 fitted first around the short edge 5B of the rectangular BPP and then stretched parallel to the long edge 5A of the BPP 2 to be snug-fitted around the opposite short edge 5B of the BPP 2.

15 In order to provide good stretching capabilities, the gasket is advantageously made of an elastomeric material. Especially useful are fluorinated elastomers, for example fluorinated carbon-based synthetic rubber, including fluoro-elastomers FKM and perfluoro-elastomers FFKM, or fluorinated silicones.

20 The BPP 2 has a flow channel pattern 4 on either side for flow of air on one side for providing oxygen to one side of a membrane and hydrogen fuel to the opposite side of the membrane. A membrane is provided between each pair of stacked BPPs. Air and hydrogen fuel, as well as coolant are transported through the stack through corresponding canals 6.

25 For easier recognition of the extension of the gasket, a corner 2A of the assembly 1 of FIG. 1a is shown in an enlarged grey-scale image in FIG. 1B, where the gasket 3 has a darker tone than the BPP. It is seen that the gasket 3 extends not only around the edge 5 of the BPP 2 but also comprises upstanding collars 7 that grip into the canal portion 6A of an adjacent BPP 2 in a stack of
30 BPPs 2 in order to fixate the positions of two adjacent BPPs 2 relatively to each other. The latter is shown for a stack of 2 BPPs in FIG. 2A. By using such gasket 3 comprising upstanding collars 7 on each of the BPPs 2, the BPPs of the entire stack are fixed in position. FIG. 2B is showing the corner 2A from the opposite side.

35

FIG. 3 illustrates the abutment of the gasket 3 against the BPP 2 in greater detail. The lateral cross section of the long part 3A of the gasket 3 is largely L-shaped with a short leg 9A and a long leg 9B forming a right angle. The short leg 9A is abutting the perimeter 5 of the BPP 2, and the long leg 9B forms a spacer between two adjacent BPPs. Inside the right angle that is formed by the two legs 9A, 9B, a set of first longitudinal ribs 8A extend from the long leg 9B. Correspondingly, a set of second longitudinal ribs 8B extend from the opposite side of the long leg 9B. The first ribs 8A are illustrated as rounded, however, this is typically also the case for the second ribs 8B as long as they are not pressed against the abutting BPP, which is why the second ribs are illustrated as having flat surfaces against the BPP 2.

Also shown in FIG. 3 is the fuel cell membrane 14 between the BPPs 2 for transport of hydrogen ions between the electrodes. In FIG. 6, the fuel cell membrane 14 is illustrated in a darker shading. As illustrated, the gaskets abuts the surface of one BPP directly with a first gasket side and abuts the membrane directly with an opposite gasket side.

As the gaskets 3 are elastic and surround the edges 5 of the BPPs 2 along the perimeter, the BPPs 2 are protected from damage of the edges 5, which is a great advantage. However, it should not prevent access to the BPP for potentially measuring the voltage of the BPP, for example for diagnosis. For allowing an electrical probe to be inserted between the gaskets 3 and get into contact with the BPP, the gasket 3 comprises a probe passage 10 that extends from the outer side of the gasket 3 to the BPP 2 behind the gasket 3. As best seen in FIG. 5, the probe passage 10 extends beyond one of the outer second ribs 8B in order to provide proper contact with the BPP 2.

As illustrated in FIG. 6, the longitudinal ribs 8A on the gasket 3 in cooperation with longitudinal projections 11 on the BPP prevent the gaskets 3 from sliding outwards and away from the BPP 2. This is important during repeated heating and cooling of the fuel cells. The longitudinal projections 11 on the BPP 2 are provided between the edge 5 of the BPP 2 and the position of the longitudinal ribs 8A of the gasket 3 when the gasket 3 abuts the edge 5 of the BPP 2. Optionally the projection is adjacent to a longitudinal rib 8A for holding the

gasket 3 in place. A similar arrangement of projections is provided for the longitudinal ribs 8B on the opposite side of the gasket 3.

5 When the BPP has protrusions 11 on the side where the membrane 14 is provided, the membrane 14 is correspondingly deformed by the protrusions 11 so that the protrusions can still fulfil the purpose of preventing portions of the gasket 3 from escaping their dedicated locations.

10 For example, the BPPs 2 are provided as pairs of an anode plate and a cathode plate, which are glued together to form a BPP. An example is illustrated in FIG. 7. Apart from the flow patterns for the hydrogen gas and the oxygen gas, typically air, for the fuel cell, there is also provided a coolant flow pattern in between the anode plate 16 and the cathode plate 17, the coolant flow pattern being provided for efficient cooling of the BPP.

15 FIG. 7 illustrates passages 13 from the canal 6 into the BPP 2. As illustrated in FIG. 1A, there are three canals 6 near either narrow edge 5B of the BPP 2. Passages 13 as illustrated in FIG. 7 are connected to each of the canals 6. One of the six canals 6 is providing coolant into a channel flow pattern that is provided in between the anode plate 16 and the cathode plate 17. Another of the six
20 canals 6 is used for drain of coolant from the BPP 2. The hydrogen gas from one of the other canals 6 is flowing into a corresponding set of passages 13 between the anode plate 16 and the cathode plate 17 of the BPP and through openings in the anode plate for reaching the flow pattern 4 on the outer anode side of the BPP. Similarly, oxygen gas, such as air, flows from a corresponding canal 6 into
25 corresponding passages 13 between the anode plate 16 and the cathode plate 17 of the BPP 2 and through openings in the cathode plate for reaching the flow pattern 4 on the outer cathode side of the BPP. Such openings 15 in flow-communication with a set of passages 13 are shown in FIG. 4. Correspondingly,
30 one canals 6 is for the water-containing oxygen depleted air from the cathode side of the BPP after the reaction in the fuel cell and another canal 6 for the anode exhaust gas.

35 Also seen in FIG. 7 are protrusions for cooperating with the gasket's second longitudinal ribs 8B, which were illustrated in FIG. 3. Similar protrusions and

cooperating ribs are provided on various other positions on the BPP 2 and the gasket 3.

5 The protrusions 11 are advantageously provided by impressing a tool onto one side of the anode plate 16 and/or cathode plate 17 and deforming the plate to receive a depression on one side and a corresponding projection on the opposite side. This can be done for metal plates but also during molding of plates that are made from conducting polymer, especially carbon-containing polymer.

Krav

- 5 1. En brændselscellestak omfattende en stak af en flerhed af bipolære plader (2), BPP'er, med ionbyttermembraner (14) mellem tilstødende BPP'er (2), hvor hver af flerheden af BPP'er (2) har et kantområde (5) langs en ydre perimenter af BPP'en, hvor en flerhed af tættnende ikke-ledende polymerpakninger (3) er tilvejebragt med én pakning (3) mellem hver to tilstødende BPP'er (2) til tætning af et volumen mellem membranen (14) og dens tilstødende BPP (2) ved hjælp af
- 10 pakningen (3), **kendetegnet ved, at** pakningen (3) støder op til og dækker kantområdet (5) og strækker sig langs og rundt om perimeteren af BPP'en (2) for at beskytte kanten (5) af den tilsvarende BPP (2) og til elektrisk og termisk isolering af BPP'en (2).
- 15 2. Stak ifølge krav 1, hvor pakningen (3) er fremstillet af et elastisk strækbart materiale med en indre omkreds, der er mindre end den ydre omkreds af BPP'en, og hvor pakningen (3) er forspændt ved forlængelse for at passe tætsiddende rundt om kanten (5) af BPP'en (2) og for at blive holdt på plads ved elastisk sammentrækning af pakningen (3) rundt om perimeteren.
- 20 3. Stak ifølge krav 2, hvor den indre omkreds af pakningen (3) er 1-5% kortere end den ydre omkreds af BPP'en (2).
- 25 4. Stak ifølge et hvilket som helst af de foregående krav, hvor stakken omfatter en kanal (6), der strækker sig fra den ene ende til den modsatte ende af stakken til strømning af gas eller kølemiddel gennem kanalen (6), hvor kanalen (6) er dannet af stakkede kanalsegmenter (6A), hvor hvert kanalsegment (6A) er en åbning, der strækker sig gennem en tilsvarende BPP (2), hvor åbningen har en kant, der afgrænser et indre volumen af kanalsegmentet (6A), hvor pakningen
- 30 (3) strækker sig rundt om perimeteren af kun én af flerheden af BPP'er (2) og strækker sig med en del (7) ind i en kanalsektion (6A) af en tilstødende BPP (2) og støder op til en del af kanten af den tilsvarende kanalsektion (6A) til fiksering af to tilstødende BPP (2) i forhold til hinanden.

5. Stak ifølge et hvilket som helst af de foregående krav, hvor pakninger (3) af tilstødende BPP'er (2) i stakken støder op til hinanden for at danne en ydre tætning langs stakken.
- 5 6. Stak ifølge et hvilket som helst af de foregående krav, hvor hver pakning (3) omfatter en sonde-åbning (10) til at modtage en elektrisk sonde, hvor sonde-åbningen (10) strækker sig fra en yderside af pakningen (3) gennem pakningen (3) og til en BPP (2) til måling af spændingen af PBB'en (2) ved hjælp af sonden.
- 10 7. Stak ifølge krav 6, hvor sonde-åbningen (10) strækker sig til en BPP (2), der støder op til den BPP, hvis pakninger (3) dækker omkredsen.
- 15 8. Stak ifølge et hvilket som helst af de foregående krav, hvor pakningen (3) omfatter en ribbe (8A) mod en første side af BPP'en (2), og BPP'en omfatter et fremspring (11) på den første side, hvor ribben (8A) og fremspringet (11) er anbragt side om side og parallelt med perimeteren, hvor ribben (8A) er tilvejebragt i en større afstand fra perimeteren end fremspringet (11), for at fremspringet (11) blokerer ribben (8A) i at passere fremspringet (11) mod perimeteren og for at forhindre pakningen (3) i at glide udad i en retning væk fra
- 20 perimeteren.
- 25 9. Stak ifølge krav 8, hvor pakningen (3) langs perimeteren har en første del (3A), der passer rundt om perimeteren af kun én BPP (2), og en anden del (3B), der strækker sig mellem to tilstødende BPP'er (2), hvor den anden del (3B) omfatter ribber (8A, 8B) på modsatte sider for at blive blokeret fra at undslippe ved hjælp af fremspring (11) fra begge af to tilstødende BPP'er (2).
- 30 10. Stak ifølge krav 9, hvor de to dele (3A, 3B) danner et første og et andet ben af en L-formet pakning (3) set i et tværsnit i et plan vinkelret på kanten (5).
11. Stak ifølge et hvilket som helst af de foregående krav, hvor pakningen (3) strækker sig ind mellem to tilstødende BPP'er (2), der omkranser kanalsektionen (6A) til tætning af kanalsektionen (6A).

12. Stak ifølge et hvilket som helst af de foregående krav, hvor BPP'en (2) på hver side omfatter et strømningsmønster (4) til strømning af brint på den ene side og strømning af ilt på den modsatte side, hvor pakningerne (3) strækker sig tæt omkring et af strømningsmønstrene for at forhindre udslip ud over kanten (5) af BPP'en (2).

13. Samling af en bipolar plade (2), BPP og en pakning (3), hvor BPP'en har et kantområde (5) langs en perimeter rundt om BPP'en (2), **kendetegnet ved, at** pakningen støder op til og dækker kanten (5) og strækker sig langs perimeteren af BPP'en (2) til beskyttelse af kanten (5) og til tætning, hvor pakningen (3) er lavet af et elastisk strækbart materiale med en indre omkreds, der er mindre end den ydre omkreds af BPP'en (2), og hvor pakningen (3) er forspændt ved forlængelse for at passe tætsiddende rundt om kanten (5) af BPP'en (2) og for at blive holdt på plads ved elastisk sammentrækning af pakningen (3) rundt om perimeteren, hvor den indre omkreds af pakningen (3) er 1-5% kortere end den ydre omkreds af BPP'en (2).

14. Samling ifølge krav 13, hvor pakningen (3) langs omkredsen (5) af BPP'en (2) har en første del (3A), der passer rundt om perimeteren af kun én BPP (2), og en anden del (3B), der strækker sig ind mellem to tilstødende BPP'er (2), hvor de to dele (3A, 3B) danner et første og et andet ben af en L-formet pakning (3), set i et tværsnit vinkelret på kanten (5).

15. Fremgangsmåde til at tilvejebringe en tætning omkring en bipolar plade (2), BPP, til en brændselscellestak omfattende en flerhed af stakkede bipolare plader (2) med ionbyttermembraner (14) mellem tilstødende BPP'er (2), hvor hver af flerheden af BPP'er (2) har et kantområde (5) langs en ydre perimeter af BPP'en (2), hvor fremgangsmåden omfatter tilvejebringelse af en flerhed af tætnende ikke-ledende polymerpakninger (3) og anbringelse af én pakning (3) mellem hver to tilstødende BPP'er (2) til tætning af et volumen mellem membranen (14) og dens tilstødende BPP (2) ved hjælp af pakningen (3), **kendetegnet ved, at** fremgangsmåden omfatter at tilvejebringe pakningen (3) med et elastisk strækbart polymermateriale med en indre omkreds, der er mindre end den ydre omkreds af BPP'en (2), og at forspænde pakningen (3) ved forlængelse ved placering af pakningen (3) på en BPP (2), for at pakningen (3) sidder tæt

omkring kanten (5) af BPP'en (2) og for at blive holdt på plads ved elastisk sammentrækning af pakningen (3) rundt om perimeteren, så pakningen (3) støder op til og dækker kanten (5) af BPP'en (2) og strækker sig langs og rundt om perimeteren af BPP'en (2) for at beskytte kanten (5) af den tilsvarende BPP (2) og til elektrisk isolering af BPP (2).

16. Fremgangsmåde ifølge krav 15, hvor den indre omkreds af pakningen (3) er 1-5% kortere end den ydre omkreds af BPP'en (2).

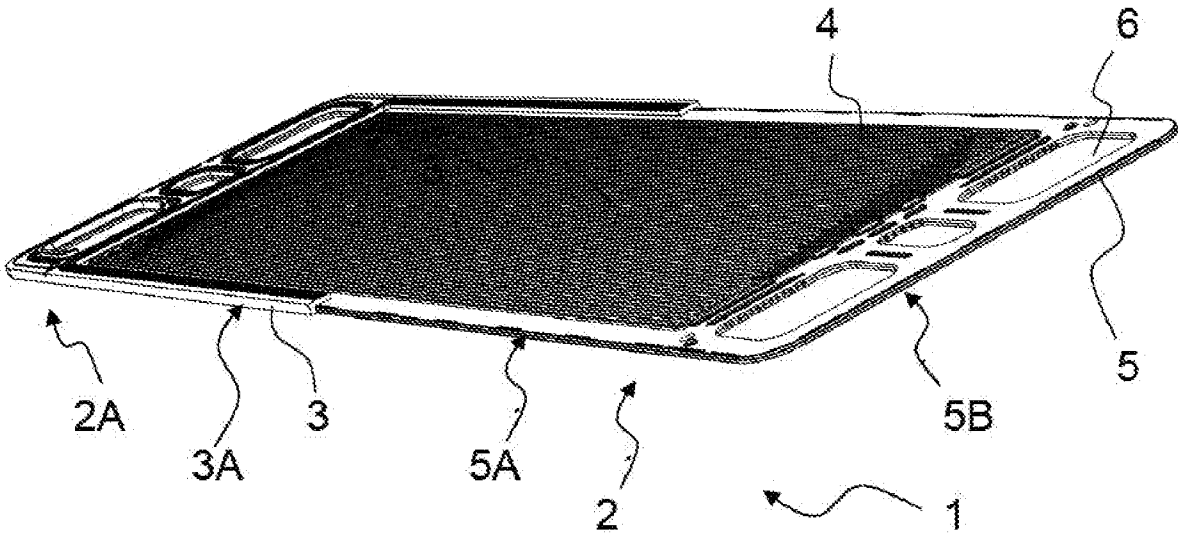

FIG. 1A

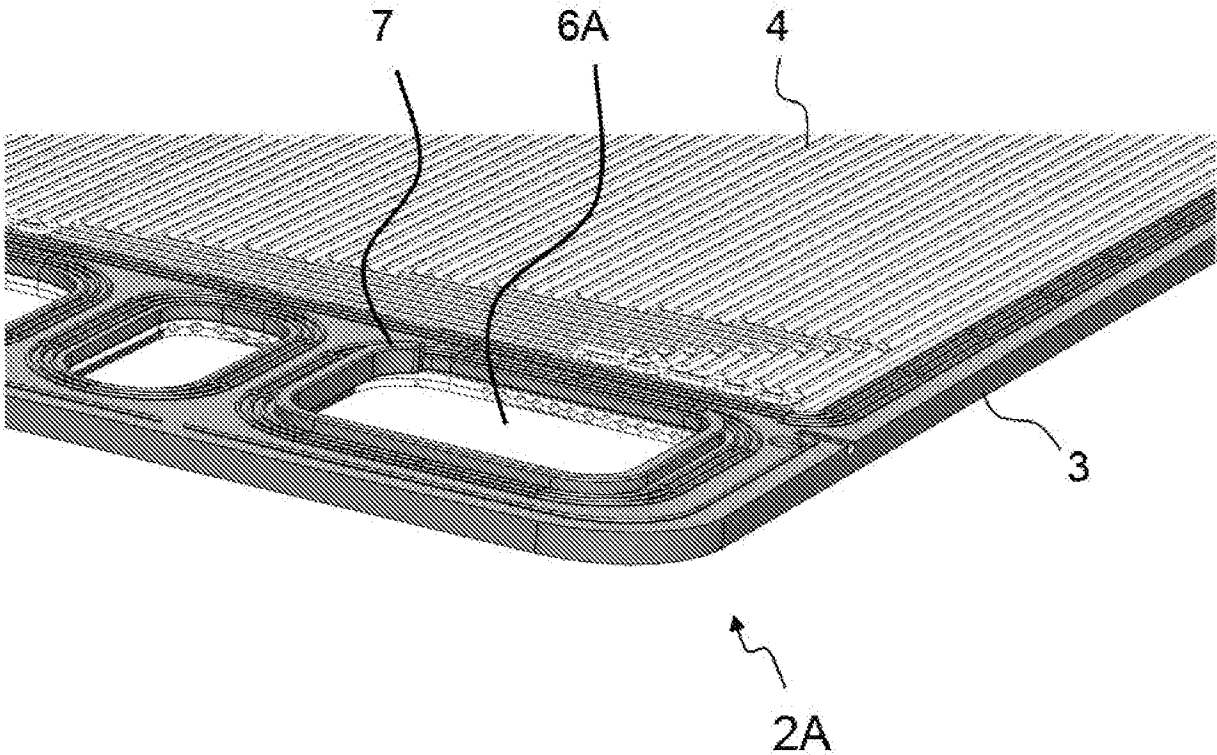

FIG. 1B

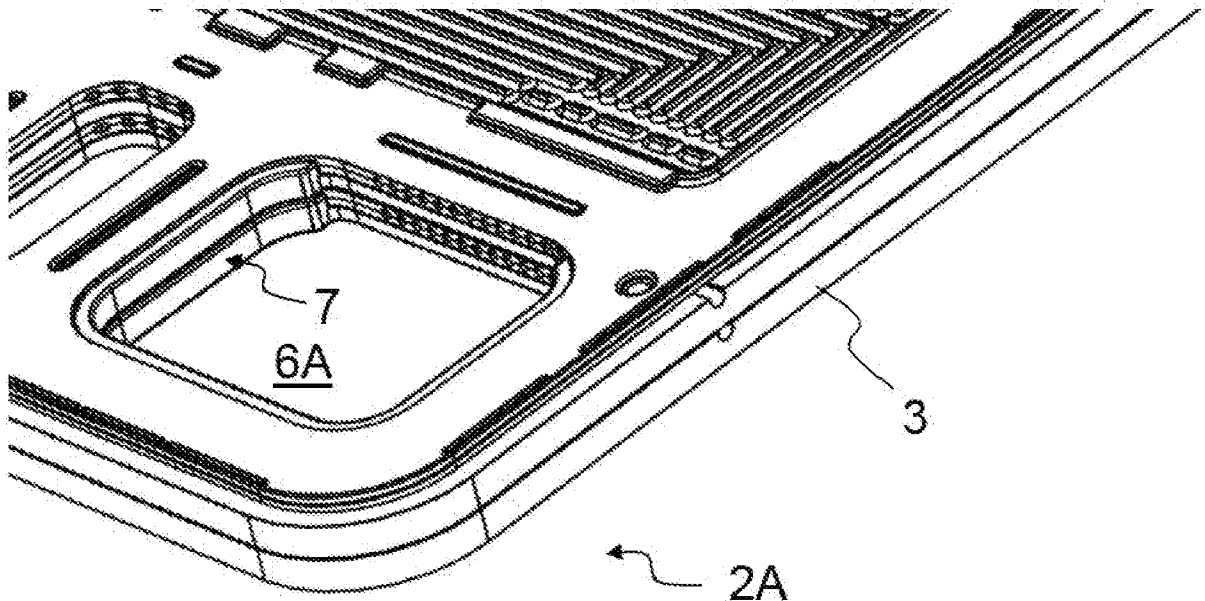

FIG. 2A

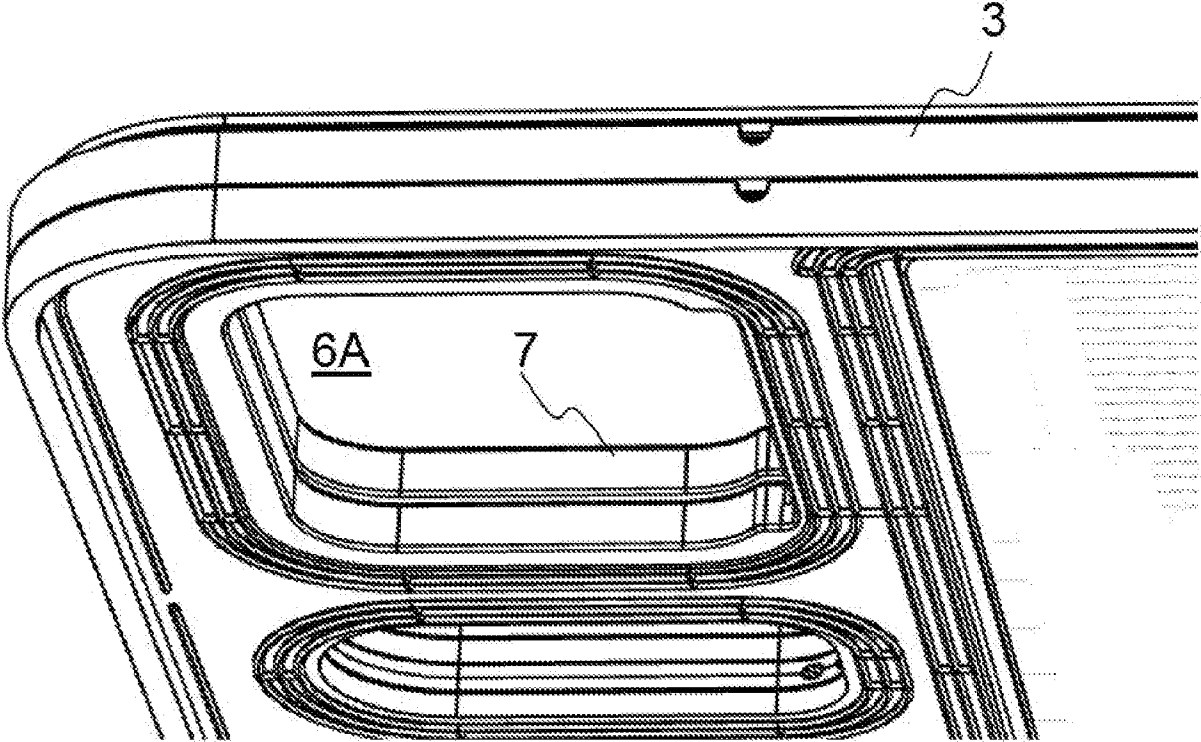

FIG. 2B

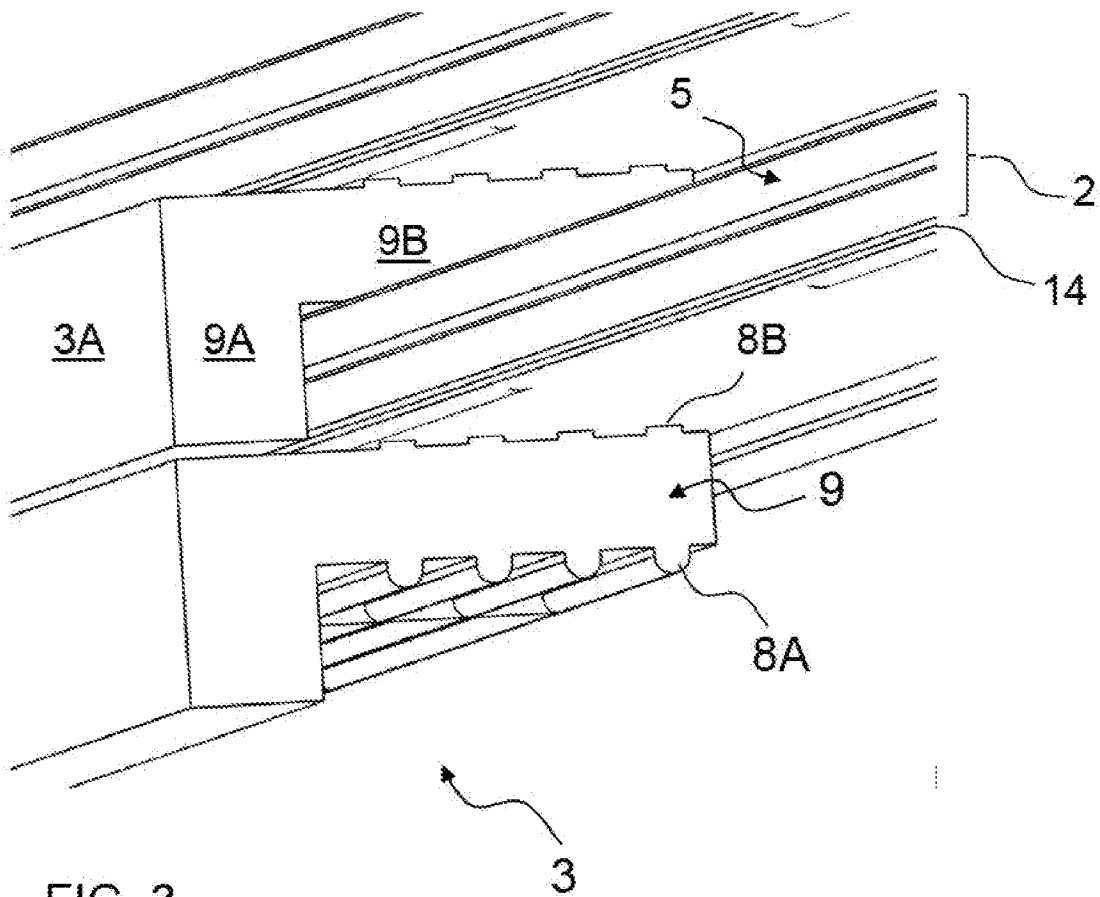

FIG. 3

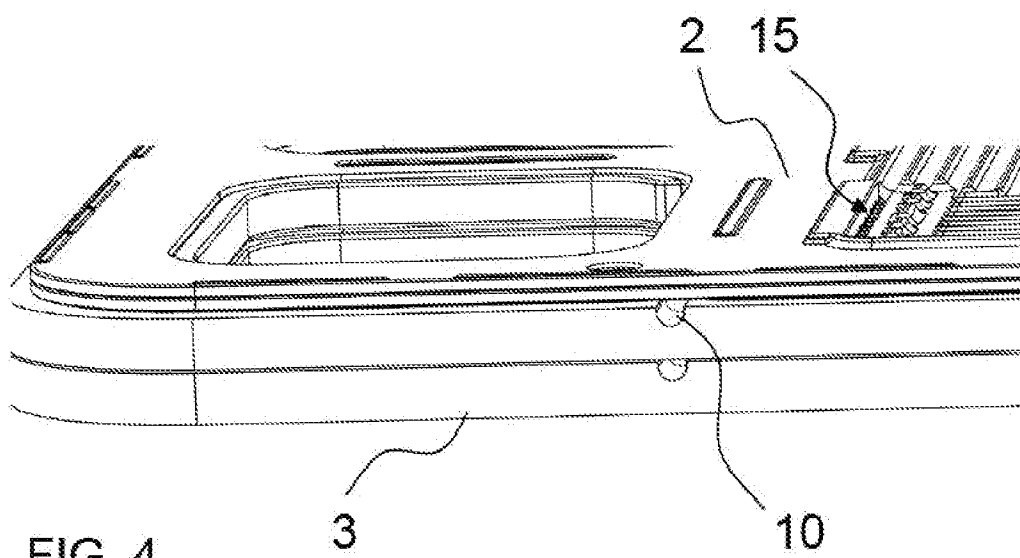

FIG. 4

4/5

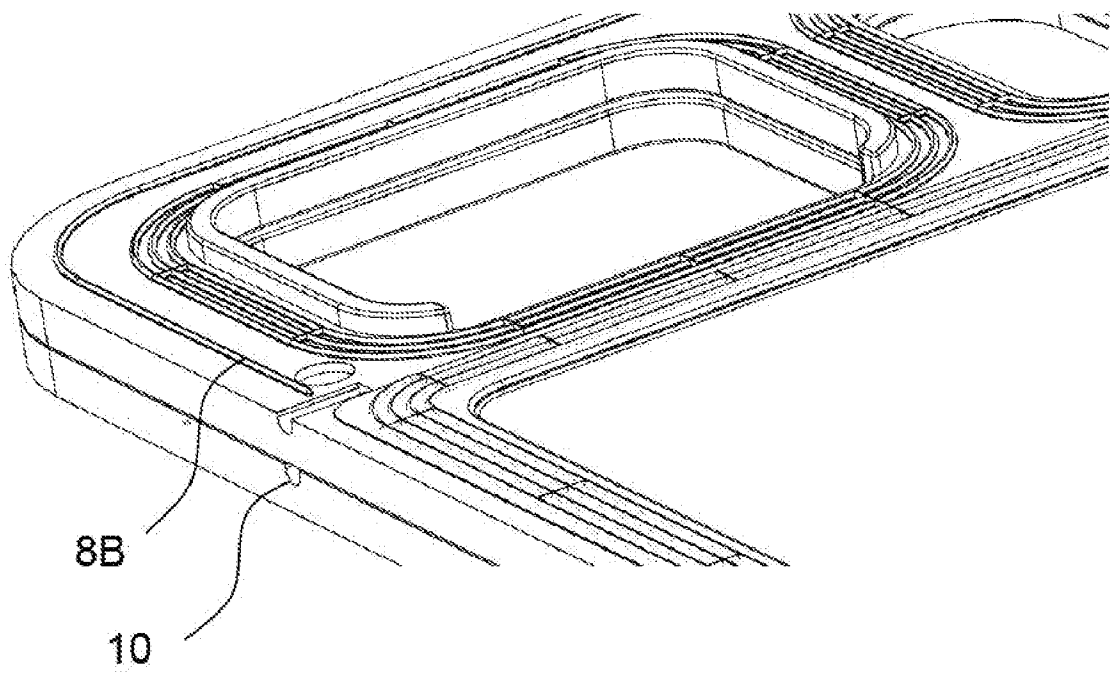

FIG. 5

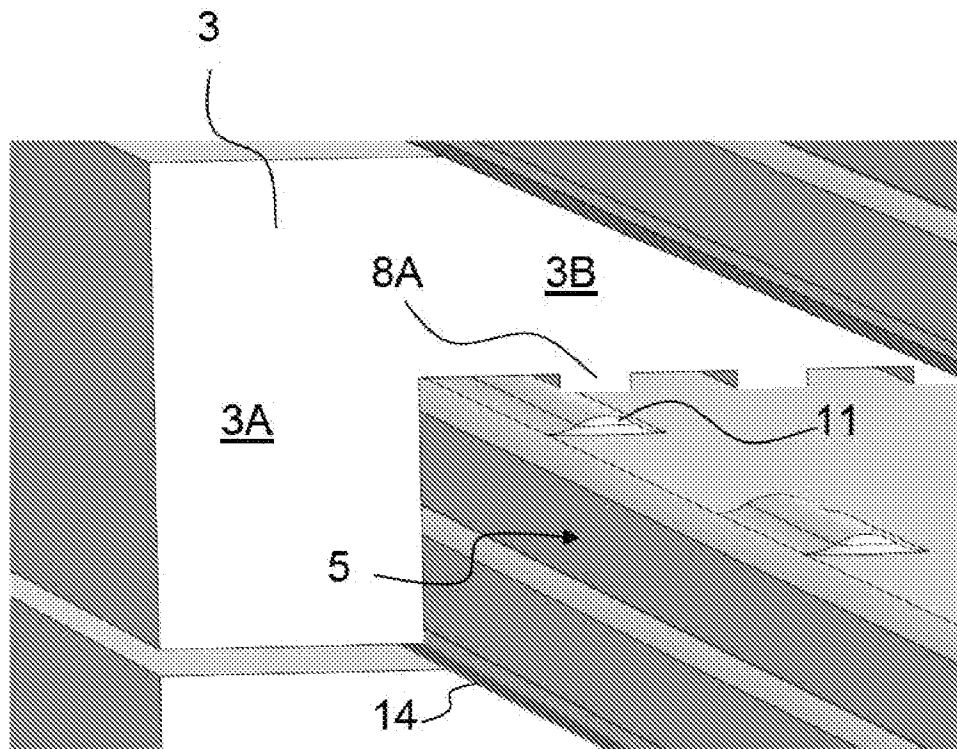

FIG. 6

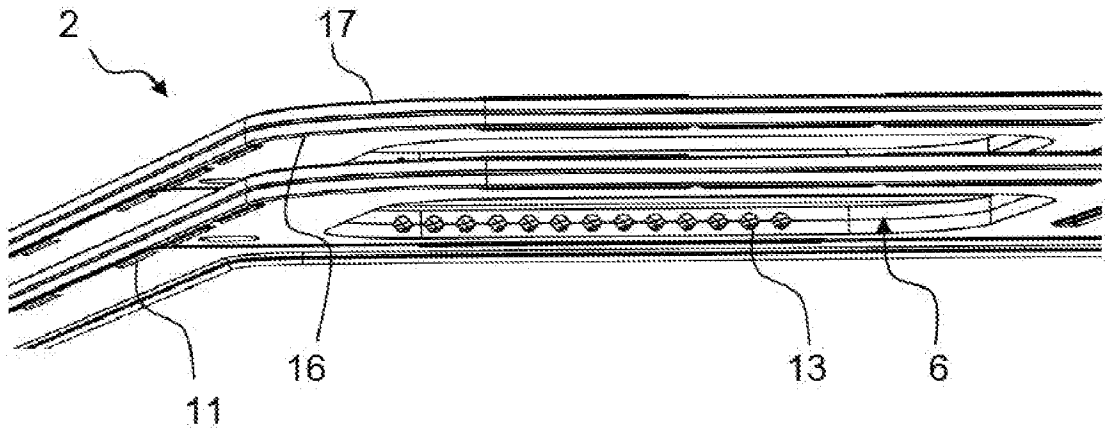

FIG. 7

SEARCH REPORT - PATENT		Application No. PA 2021 00560
1. <input type="checkbox"/> Certain claims were found unsearchable (See Box No. I).		
2. <input type="checkbox"/> Unity of invention is lacking prior to search (See Box No. II).		
A. CLASSIFICATION OF SUBJECT MATTER H01M 8/0202 (2006.01), F16J 15/02 (2006.01). According to International Patent Classification (IPC)		
B. FIELDS SEARCHED		
PCT-minimum documentation searched (classification system followed by classification symbols) IPC&CPC:F16J, H01M.		
Documentation searched other than minimum documentation to the extent that such documents are included in the fields searched DK, NO, SE, FI: IPC-classes H01M.		
Electronic database consulted during the search (name of database and, where practicable, search terms used) WPI, EPODOC, FULL TEXT: ENGLISH.		
C. DOCUMENTS CONSIDERED TO BE RELEVANT		
Category*	Citation of document, with indication, where appropriate, of the relevant passages	Relevant for claim No.
A,D	<u>US 2003/0215692</u> A1 (ROCK JEFFREY A et al.) 2003.11.20 Paragraphs [0002] - [0004], [0046] - [0047] and Fig. 1.	1-16
A	<u>WO 00/54352</u> A1 (FLEXFAB HORIZONS INT INC et al.) 2000.09.14 Page 3, line 15 to page 4, line 17.	1-16
A	<u>WO 2015/060517</u> A1 (HYUNDAI HYSCO CO LTD) 2015.04.30 Paragraphs [53][54].	1-16
A,D	<u>US 2010/0143817</u> A1 (BANG MADS et al.) 2010.06.10	1-16
A	<u>EP 3246975</u> A1 (HYUNDAI MOTOR CO LTD) 2017.11.22 Paragraphs [0010] [0011].	1-16
<input type="checkbox"/> Further documents are listed in the continuation of Box C.		
* Special categories of cited documents:	"P" Document published prior to the filing date but later than the priority date claimed.	
"A" Document defining the general state of the art which is not considered to be of particular relevance.	"T" Document not in conflict with the application but cited to understand the principle or theory underlying the invention.	
"D" Document cited in the application.	"X" Document of particular relevance; the claimed invention cannot be considered novel or cannot be considered to involve an inventive step when the document is taken alone.	
"E" Earlier application or patent but published on or after the filing date.	"Y" Document of particular relevance; the claimed invention cannot be considered to involve an inventive step when the document is combined with one or more other such documents, such combination being obvious to a person skilled in the art.	
"L" Document which may throw doubt on priority claim(s) or which is cited to establish the publication date of another citation or other special reason (as specified).	"&" Document member of the same patent family.	
"O" Document referring to an oral disclosure, use, exhibition or other means.		
Danish Patent and Trademark Office Helgeshoj Allé 81 DK-2630 Taastrup Denmark Tel.: +45 4350 8000	Date of completion of the search report 22 November 2021	
	Authorized officer Erik Lund Tel.: +45 43 50 81 40	

SEARCH REPORT - PATENT		Application No. PA 2021 00560
C (Continuation). DOCUMENTS CONSIDERED TO BE RELEVANT		
Category*	Citation of document, with indication, where appropriate, of the relevant passages	Relevant for claim No.

SEARCH REPORT - PATENT	Application No. PA 2021 00560
Box No. I Observations where certain claims were found unsearchable	
<p>This search report has not been established in respect of certain claims for the following reasons:</p> <p>1. <input type="checkbox"/> Claims Nos.: because they relate to subject matter not required to be searched, namely:</p> <p>2. <input type="checkbox"/> Claims Nos.: because they relate to parts of the patent application that do not comply with the prescribed requirements to such an extent that no meaningful search can be carried out, specifically:</p> <p>3. <input type="checkbox"/> Claims Nos.: because of other matters.</p>	
Box No. II Observations where unity of invention is lacking prior to the search	
<p>The Danish Patent and Trademark Office found multiple inventions in this patent application, as follows:</p>	
SEARCH REPORT - PATENT	Application No. PA 2021 00560

SUPPLEMENTAL BOX

Continuation of Box [.]