

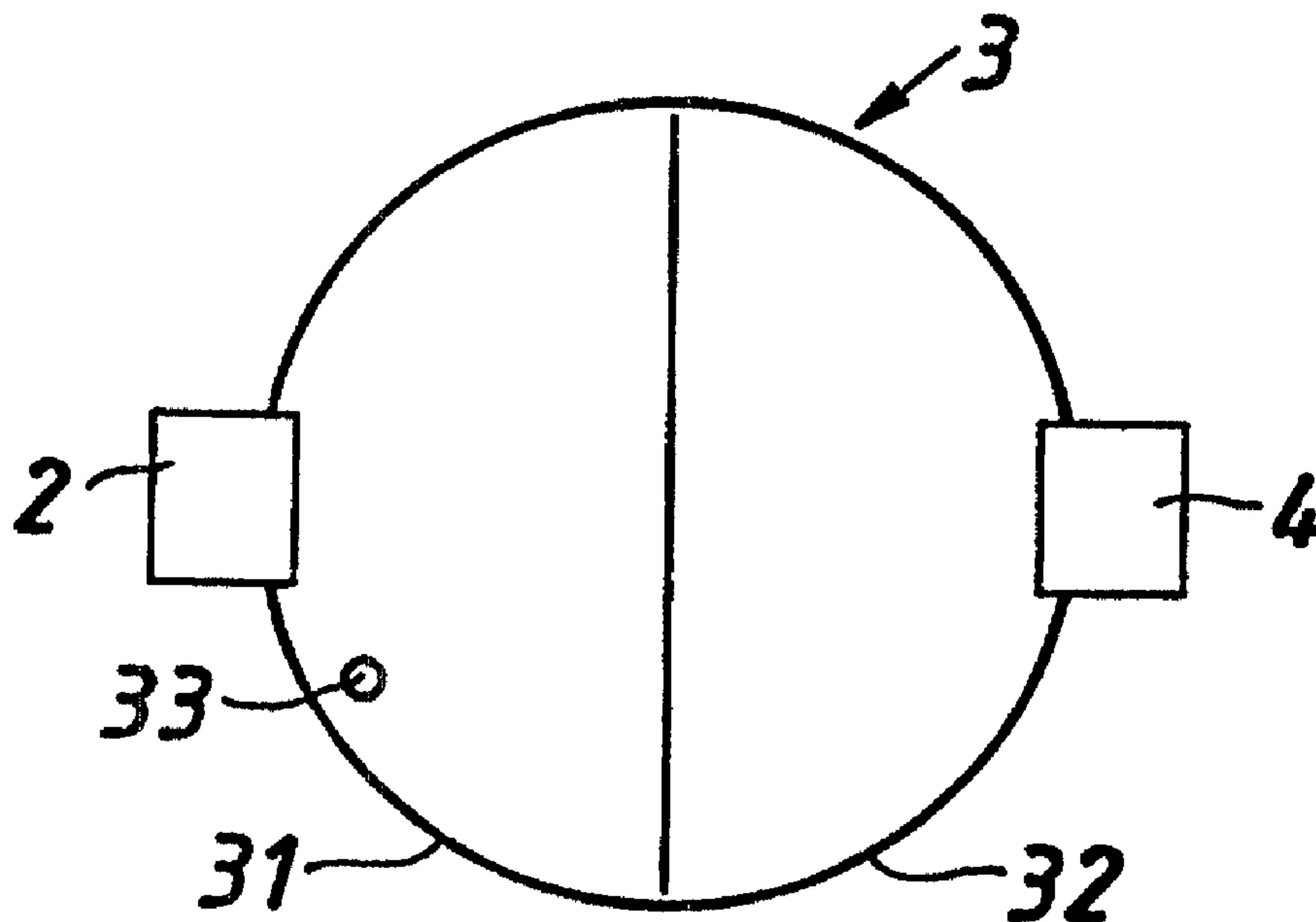

(86) Date de dépôt PCT/PCT Filing Date: 1999/06/17
 (87) Date publication PCT/PCT Publication Date: 1999/12/29
 (45) Date de délivrance/Issue Date: 2004/04/06
 (85) Entrée phase nationale/National Entry: 2000/12/06
 (86) N° demande PCT/PCT Application No.: GB 1999/001931
 (87) N° publication PCT/PCT Publication No.: 1999/067629
 (30) Priorité/Priority: 1998/06/24 (9813509.8) GB

(51) Cl.Int.⁶/Int.Cl.⁶ G01N 29/18, G01H 5/00
 (72) Inventeurs/Inventors:
 HUMPHREY, FRANCIS ALAN, GB;
 BYRNE, DAVID, GB;
 PRICE, BARRY LEONARD, GB
 (73) Propriétaire/Owner:
 LATTICE INTELLECTUAL PROPERTY LTD, GB
 (74) Agent: GOWLING LAFLEUR HENDERSON LLP

(54) Titre : MESURE DE LA VITESSE DU SON D'UN GAZ
 (54) Title: MEASURING THE SPEED OF SOUND OF A GAS



(57) Abrégé/Abstract:

A method and apparatus for determining the speed of sound in a gas. An acoustic transmitter is arranged to apply an acoustic signal to the interior of a resonator and an acoustic receiver is arranged to detect the amplitude of the acoustic signal in the interior of the resonator. A control means determines the speed of sound of gas within the resonator from the frequency of a detected non-radial resonant mode.

PCTWORLD INTELLECTUAL PROPERTY ORGANIZATION
International Bureau

INTERNATIONAL APPLICATION PUBLISHED UNDER THE PATENT COOPERATION TREATY (PCT)

<p>(51) International Patent Classification ⁶ : G01N 29/02</p>	<p>A1</p>	<p>(11) International Publication Number: WO 99/67629</p> <p>(43) International Publication Date: 29 December 1999 (29.12.99)</p>
<p>(21) International Application Number: PCT/GB99/01931</p> <p>(22) International Filing Date: 17 June 1999 (17.06.99)</p> <p>(30) Priority Data: 9813509.8 24 June 1998 (24.06.98) GB</p> <p>(71) Applicant (for all designated States except US): BG PLC [GB/GB]; 100 Thames Valley Park Drive, Reading, Berkshire RG6 1PT (GB).</p> <p>(72) Inventors; and (75) Inventors/Applicants (for US only): HUMPHREY, Francis, Alan [GB/GB]; 193 Grange Drive, Melton Mowbray, Leicestershire LE13 1EL (GB). BYRNE, David [GB/GB]; 45 Juniper Way, Loughborough, Leicestershire LE11 2QA (GB). PRICE, Barry, Leonard [GB/GB]; 4 Swinfield Road, Quorn, Leicestershire LE12 8RJ (GB).</p> <p>(74) Agent: ILLINGWORTH-LAW, William; BG plc, Intellectual Property Dept., 100 Thames Valley Park Drive, Reading, Berkshire RG6 1PT (GB).</p>		<p>(81) Designated States: AU, BR, CA, IN, JP, KR, MX, SG, US, European patent (AT, BE, CH, CY, DE, DK, ES, FI, FR, GB, GR, IE, IT, LU, MC, NL, PT, SE).</p> <p>Published <i>With international search report.</i></p>
<p>(54) Title: MEASURING THE SPEED OF SOUND OF A GAS</p>		
<p>(57) Abstract</p> <p>A method and apparatus for determining the speed of sound in a gas. An acoustic transmitter is arranged to apply an acoustic signal to the interior of a resonator and an acoustic receiver is arranged to detect the amplitude of the acoustic signal in the interior of the resonator. A control means determines the speed of sound of gas within the resonator from the frequency of a detected non-radial resonant mode.</p> <div style="text-align: center;"> </div>		

MEASURING THE SPEED OF SOUND OF A GAS

The present invention relates to a method and an apparatus for measuring the speed of sound of a gas. The speed of sound of a gas is particularly useful for determining other gas characteristics.

Accurate measurements of the speed of sound of a gas may be made using a resonator as disclosed in an article entitled Spherical Acoustic Resonators by M. Bretz, M.L. Shapiro and M.R. Moldover in volume 57 of the American Journal of Physics. The resonator containing a sample of a test gas has an acoustic transmitter and an acoustic receiver mounted in its wall. The acoustic transmitter is driven over a range of frequencies and the amplitude of the signal provided by the acoustic receiver is detected for each frequency at which the acoustic transmitter is driven. The frequency at which the acoustic receiver picks up the strongest, sharpest signal is the first resonant radial mode is detected. Since the resonating frequency is a linear function of the speed of sound of the test gas in the resonator, the speed of sound of the test gas may be determined.

For a spherical resonator of given radius, the enclosed gas will exhibit a series of acoustic resonances. The resonances are the result of three dimensional standing

waves. For a perfect system the resonant frequencies (f) are a function of the root of a spherical Bessel function (z), the speed of sound (c) and the radius of the sphere (r) given by:

$$f = cz/(2\pi r)$$

The radial mode is used because in this mode sound impinges on the wall of the sphere at right angles and so does not suffer energy loss due to viscous drag and so produces a sharp resonant peak which is not difficult to detect accurately.

Previous researches using a basic mathematical model of acoustic spherical resonators have reported an accuracy of 0.02% in speed of sound measurements.

However, since the resonant frequency of the spherical resonator is inversely proportional to the radius of the sphere, the resonator normally has a diameter of at least 12 cm to produce a first resonant radial mode within the frequency range of the acoustic transducers. However, a resonator of this size is too large to be used in a probe to be inserted conveniently into a source of gas such as a gas pipe or for use in a convenient and compact housing. If the resonator were to be reduced to a sphere of diameter 3 cm for example the first resonant radial mode would occur at about 18 kHz which would be beyond the range of acoustic transducers (20 Hz -13

kHz).

According to a first aspect of the present invention an apparatus for determining the speed of sound of a gas comprises:

a substantially spherical resonator for containing gas to be tested;

an acoustic transmitter for applying an acoustic signal to the interior of the resonator;

an acoustic receiver for detecting the amplitude of the acoustic signal in the interior of the resonator; and

control means for determining the speed of sound of a test gas from the frequency of a detected resonant mode;

wherein the detected resonant mode is a non-radial resonant mode and the internal radius of the resonator is substantially 5cm or less.

According to a further aspect of the present invention a method of determining the speed of sound of a gas comprises:

applying an acoustic signal to the interior of a substantially spherical resonator containing a gas the speed of sound of which is to be determined;

detecting the amplitude of the acoustic signal in the interior of the resonator;

and

determining the speed of sound of the gas within the resonator from the frequency of a detected resonant mode;

wherein the detected resonant mode is a non-radial resonant mode and the internal radius of the resonator is substantially 5 cm or less.

The inventor uses a first non-radial resonance which occurs at a frequency below that of the previously used first resonant radial mode. This first non-radial mode can be used to detect the speed of sound with resonators of smaller size than previously whilst still maintaining the resonant frequency within the range of the transducers. Consequently a more compact resonator may be used as a probe for example and may be inserted into existing gas pipes or installed into a more compact housing for greater convenience whilst still producing accurate results.

The resonator may have an internal radius of substantially 4 cm or less, 3 cm or less, 2 cm or less or preferably substantially 1.5 cm or less to make it conveniently compact.

For a substantially spherical resonator with a radius of 1.5cm it has been found that the first non-radial mode occurs in a gas at around 9 kHz which is well within the frequency range of acoustic transducers (20 Hz - 13kHz).

The use of spherical resonators gives the most accurate speed of sound measurements. Because the sphere is symmetrical in all planes through its centre, corrections due to thermal expansion etc can be relatively easily applied.

Additionally, the acoustic transmitter and receiver can be positioned outside the resonator cavity and hence do not significantly perturb the resonating system. In contrast, using a cylinder, the acoustic transmitter and receiver affect the path length and any expansion in the transmitter and receiver must be allowed for as well as the expansion of the cylinder.

It has been found that the relative linear position of the acoustic transmitter and receiver is critical in achieving a sharp resonance curve for the first non radial resonant mode to provide accurate resonant frequency and hence speed of sound measurements. It has been found that this relative position may be slightly different for each resonator due to constructional variations. To allow for this the acoustic transmitter and receiver are preferably mountable to the resonator such that their relative separation is variable. Their relative positions can then be varied during calibrating to achieve optimum peak sharpness.

For the first non-radial mode, when the resonator is substantially spherically shaped, the acoustic transmitter and receiver are preferably positioned substantially opposite each other ie substantially 180° apart for the largest amplitude detected peak.

Previously acoustic transmitters have operated at high voltages, eg 150 V for the transmitter in the article by M.Bretz et al mentioned above. However, this can be

potentially hazardous if the resonator is working with a highly combustible gas eg methane or natural gas. The smaller resonator of the present invention may be used with a miniature, low voltage, eg 5 volt transmitter as may be used as a hearing aid speaker for greater safety.

The invention is described further by way of example with reference to the accompanying drawings in which:

Figure 1 is a block diagram illustrating the overall operation of a system to measure the speed of sound of a gas using a resonator;

Figure 2 shows a substantially spherical resonator that can be used in the system;

Figure 3 shows how the acoustic receiver is mounted to the resonator;

Figure 4 shows how the acoustic transmitter is mounted to the resonator;

Figure 5 shows the amplitude of a signal detected by the acoustic receiver over a range of frequencies;

Figure 6 illustrates how a clock signal is used to produce pulse width modulated signals which are combined to produce an approximation to a sine wave;

Figure 7 shows an electronic system to perform the operation illustrated in Figure 6,

Figure 8 shows a voltage controlled oscillator to supply the clock signal to the system shown in Figure 6;

Figure 9 shows a sequence of operations to determine the resonant frequency;

Figure 10 shows the connections to a processing means to determine resonant frequency; and

Figure 11 shows a method of allowing for the finite hardware response time.

As shown by Figure 1, driving electronic circuit 1 which may include or be in the form of a microprocessor is arranged to produce a sinusoidal signal over a suitable range of frequencies to drive a loudspeaker 2. The loudspeaker is arranged to apply an acoustic signal to the interior of a resonator 3. Microphone 4 is arranged to pick up the magnitude of the acoustic signal within the resonator. The signal from the microphone is filtered and amplified by an appropriate electronic circuit 5 and a processing means 6 determines the resonant frequency relating to the gas within the resonator to determine its speed of sound.

The resonator 3 shown in Figure 2 is in this case a rigid sphere. The illustrated

resonator is formed from two CNC (computer numerically controlled) machined metal hemispheres 31,32, in this case made of copper, of internal radius 1.5cm and 3mm wall thickness welded together to form the sphere.

The apexes of hemispheres 31,32 support the loudspeaker 2 and microphone 4 respectively which when the hemispheres are joined as shown in figure 2 are substantially 180° apart to provide the largest amplitude microphone signal.

The resonator is provided with a number of gas diffusion passages 33, only one of which is shown in Figure 2, to enable gas to diffuse in and out of the resonator 3. Each hemisphere 31, 32 is preferably provided with four gas diffusion passages 33 positioned 90° apart. Gas diffusion passages 33 are preferably drilled through the resonator housing and any swarf removed to present a regular repeatable surface to the inside of the resonator.

Alternatively the resonating sphere could be made from a porous material such as a sintered material. Gas diffusion holes 33 shown in the copper resonating sphere of figure 2 would then not be required and so would reduce perturbations in the resonant frequency due to the holes 33. The porous material used would preferably have a lower thermal expansion than copper, reducing the amount of correction required for variation in the size of the resonator with ambient temperature changes.

The loudspeaker 2 is in this case a miniature loudspeaker as may be used in a hearing aid with a supply voltage of 5V and a power level of approximately 33mW and the microphone 4 is a sub-miniature microphone.

Figure 3 shows how the microphone 4 is mounted to the resonator 3. The resonator is provided with a passage 41 of approximately 1.5mm diameter which is preferably drilled and any swarf removed. A cylindrical spindle 42 is mounted to or formed as part of the outside of the resonator and is arranged concentrically with the passage 41. The spindle 42 is preferably approximately 10mm in length and has an inner diameter sufficient to accommodate the microphone 4, in this case approximately 5mm. The position of the microphone 4 within the spindle is variable along its length so that it may be positioned at the optimum point at which the sharpest output signal peak is produced, when the loudspeaker applies the resonant frequency to the resonator. The microphone 4 is secured at the optimum position within the spindle 42 using adhesive 43. The adhesive is preferably prevented from entering the resonator cavity as it could dry in irregular shapes which may cause perturbations in the resonant frequency. The microphone 4 is preferably provided with a rim 45, the outside diameter of which is substantially the same as the inside diameter of the spindle 42 to prevent any adhesive entering the resonator. Alternatively the microphone 4 could fit tightly in the spindle 42. The microphone 4 is connected to the driving electronics 1 by an electrical connection 46.

The loudspeaker 2 may be mounted in the same manner as the microphone 4 shown in Figure 3, but is in this example fixed at a particular distance from the inside of the resonator as shown in Figure 4.

In Figure 4 a spindle 21 of approximately 2mm length is mounted to or formed as part of the outside wall of the resonator 3 and a 1.5mm passage 22 drilled through the spindle 21 and the resonator wall with any swarf removed. The loudspeaker 2 is mounted to the outside of the spindle 21 covering the passage 22. The loudspeaker is secured to the spindle 21 using adhesive, ensuring that no adhesive enters passage 22 and is electrically connected to filtering and amplifying electronics 5 by electrical connection 23.

The position of both the microphone and loudspeaker may be variable to attain the sharpest output peak or alternatively either the microphone or loudspeaker may be fixed with the position of the other being variable.

Because of slight variations in each resonating sphere due to machining tolerances for example producing different effective radii, each resonator is calibrated individually using the expression:

$$c = f \times K$$

Each resonator is calibrated using a gas of known speed of sound (c) found using a computer model for predicting gas characteristics such as GASVLE or by measurement using some suitable method. The resonant frequency (f) is then measured for the gas of known speed of sound in the resonator being calibrated and the constant K found. Using the calibrated resonator together with its associated constant K allows the speed of sound to be determined for any gas from the measured resonant frequency. This gives accuracies of about 0.1%. By compensating for variations in ambient temperature affecting the volume of the resonator, the speed of sound of a gas may be determined to even better accuracies of about 0.05%.

The loudspeaker is driven by an electronic circuit 1 shown diagrammatically in Figure 1 to provide sinusoidal signals over a frequency range suitable to encompass the frequency of the first non-radial resonance peak of the resonator 3. The loudspeaker is driven in frequency sweeps. The microphone provides an output voltage, which is filtered and amplified, corresponding to the frequency at which the loudspeaker is currently being driven as shown graphically in Figure 5 with a small delay due to electronics. The frequency at which the microphone produces the largest output voltage is determined to be the non-radial resonant frequency which in Figure 5 is 8860 Hz at 20°C.

The generation of approximations to sine waves over a continuous range of frequencies is described below.

As shown in Figures 6 and 7, a clock signal 101 is applied to a microprocessor 110 on line 111 from a voltage controlled oscillator. Any suitable microprocessor may be used such as a Hitachi^{*} HD6473048F16. The microprocessor 110 processes the input clock signal 101 from line 111 to produce pulse width modulated (PWM) signals 102, 103 and 104 shown in Figure 6, each of the same frequency on lines 112, 113 and 114 respectively. The PWM signals 102, 103, 104 are combined together using a weighted summing arrangement, in this case consisting of resistors 115, 116, 117 to produce the approximation to a sine wave on line 118. The approximation to a sine wave 105 shown in Figure 6 has the same frequency as the PWM signals 102, 103, 104 which each have fixed duty cycles (percentage time on to percentage time off).

In this example each cycle of the synthesised approximation to a sine wave 105 corresponds to sixteen cycles of the clock signal 101, but could be eight or thirty two or any other suitable amount. The rising 121 and falling 122 edges of PWM signal 102 are triggered by the completion of the sixth and tenth cycles of the clock signal 101 respectively. The rising 131 and falling 132 edges of PWM signal 103 are triggered by the completion of the fourth and twelfth cycles of the clock signal 101 respectively. The rising 141 and falling 142 edges of PWM signal 104 are

* Trade-mark

triggered by the completion of the second and fourteenth cycles of the clock signal 101 respectively.

Each of PWM signals 102,103 and 104 is then passed through a weighting resistor 115,116,117 respectively. The ratio of the values of resistors 115,116,117 is chosen to give the best overall sine wave approximation which in this case is resistor 115 being 51 k Ω , resistor 116 being 36 K Ω and resistor 117 being 51 k Ω .

To produce an approximation to a sine wave from PWM square waves it is desirable to maintain the first harmonic whilst suppressing the third, fifth, seventh etc harmonics. Using the above method as illustrated in Figure 6 the third and fifth harmonics are essentially removed apart from some residual effects due to resistor tolerances. In the present example it is envisaged that the sine wave generating apparatus will be used to generate sine waves in the range of 7.5kHz-11.8kHz to drive the loudspeaker 2 and the transmitted signal from the loudspeaker detected by the microphone 4. When used in this manner the seventh and subsequent harmonics are reduced to levels such that no further filtering or conditioning should be needed to remove the effect of these harmonics since the transmitted signal due to these harmonics should lie outside the band-pass limits of the microphone. If the apparatus is used to generate sine waves at lower frequencies, the effect of the seventh and subsequent harmonics could be removed or diminished by low pass filtering or using more pulse width modulated signals to produce a better

approximation to a sine wave.

The output from each resistor 115,116,117 is combined at common line 118 to produce the approximation to a sine wave 105 shown in Figure 6. The signal 105 is low pass filtered by capacitor 119 connected between common line 118 and earth and is detected at connection point 120.

Figure 8 shows a voltage controlled oscillator 160 which produces an oscillating output at 161, the frequency of which is dependent upon the voltage of a driving signal applied at input 162. However any device the output frequency of which is dependent upon the analogue value of an input is suitable.

The present example of the invention uses an Analog Devices AD654 voltage to frequency converter. The AD654's block diagram appears in Figure 8. A versatile operational amplifier 163 serves as the input stage; its purpose is to convert and scale the input voltage signal 162 to a drive current. A drive current is delivered to current to frequency converter 165 (an astable multivibrator). The output of converter 165 controls transistor 164.

In the connection scheme of Figure 8, the input amplifier 163 presents a very high (250 M Ω) impedance to the input voltage at 162, which is converted into the appropriate drive current by the scaling resistor 167 at Pin 3. In this example

resistors 167 and 168 are 1.2 k Ω .

The frequency of the approximation to a sine wave produced at the output connection point 120 shown in Figure 7 cannot always be accurately assumed from the voltage of the driving signal applied at input 162 shown in Figure 8 due to variations in temperature and the performance of electrical components for example. Consequently the microprocessor 110 may also be connected to any of lines 112,113 or 114 carrying PWM signals 102,103 and 104 respectively which are at the same frequency as the output approximation to a sine wave as described later. The microprocessor counts the number of cycles of the selected PWM signal over a given period of time such as one second. The actual output frequency of the sine wave can then be accurately determined. The microprocessor 110 counts the number of cycles of a PWM signal 102,103,104 rather than the cycles of the approximation to a sine wave 105 over a given period of time as the PWM signals have more precisely defined, clear on/off states which are easier to count providing better results.

Alternatively the microprocessor 110 could count the number of cycles of the clock signal 101 over a given period of time and from this determine the sine wave frequency by dividing by the number of clock signal cycles required to produce each PWM signal cycle.

Alternatively or additionally the microprocessor may measure the time taken to produce a predetermined number of clock cycles or PWM cycles and from this calculate the frequency of the approximation to a sine wave.

As the oscillator 160 produces an oscillating signal with a continuous range of frequencies, sine waves may be generated with a continuous range of frequencies.

Use of a variable frequency square wave generating oscillator which is a readily available, small, (9.91mm x 7.87mm x 4.57mm in 8-pin plastic DIP form or 4.90mm x 3.91mm x 2.39mm in 8-Pin SOIC form for the AD 654), cheap device in conjunction with a microprocessor to produce approximations to a sine wave enables the production of a device which is able to generate approximations to sine waves over a continuous range of frequencies and which is compact and so may be mounted on a compact probe for example or in a compact housing. Since a microprocessor is generally employed in many probes or electronic systems for other purposes, the only additional space that is required to produce approximations to sine waves over a continuous range of frequencies is that for the compact variable frequency square wave generating oscillator.

The oscillator need not be a voltage controlled oscillator but may be any device arranged to supply a signal with a continuous range of frequencies.

The approximation to a sine wave need not be generated from three PWM signals but could be generated from any suitable number depending upon the required level of the approximation to a sine wave. Furthermore each cycle of the sine wave need not correspond to sixteen clock cycles but could be eight, thirty two or any suitable number.

To quickly and accurately determine the resonant frequency (the frequency at which the amplitude of the signal produced by the microphone is a maximum) an initial fast, coarse frequency sweep is made (in this case 10-15 Hz steps) over the frequency range in which the resonance may occur as shown by S1 in Figure 9. A control means such as a microprocessor identifies a narrower frequency range within the initial coarse frequency sweep in which a maximum occurs. A further frequency sweep S2 is made with smaller frequency steps (in this case 1Hz) within this identified narrower frequency range to accurately determine the frequency at which the maximum occurs, identifying the frequency of resonance.

Using the above combination of coarse then fine frequency sweeps over a narrower frequency range, an accurate value of the resonant frequency may be quickly determined for example in a fraction of a second. A control means such as a microprocessor may average subsequent detected frequency values S3 to reduce errors due to noise. The frequency of the PWM signal may then be determined S4 to indicate the frequency of the generated sine wave driving the loudspeaker 2 at

resonance.

The determination of the resonant frequency will now be explained in detail.

A microprocessor, which in this case is the microprocessor 110 described earlier which also generates the PWM signals, is used to perform an algorithm to determine the resonant frequency of the gas within the resonator. Instead of the microprocessor 110 a PC could be used with an appropriate plug-in data acquisition card.

To determine the resonant frequency, as shown in Figure 10, the microprocessor 110 has an analogue output 201, a digital input 202 and an analogue input 203.

The analogue output 201 is connected to input 162 of voltage to frequency convertor 160 shown in Figure 8, to control the frequency applied to loudspeaker 2. In this case the analogue output 201 consists of two outputs (not shown), both of which are connected to input 162 of voltage to frequency converter 160. One output controls the coarse frequency sweep and the other controls the fine frequency sweep. Each of the two outputs is passed through a digital to analogue converter, which in this case is provided in the microprocessor 110 itself, and an appropriate resistor to provide the required level of resolution. In this case the

resistor for the coarse frequency control is $36\text{k}\Omega$ and the resistor for the fine frequency control is $2.2\text{M}\Omega$.

As explained earlier, the frequency of the approximation to a sine wave signal which drives the loudspeaker cannot always be accurately assumed from the voltage of the driving signal from analogue output 201 due to temperature variations and the performance of electrical components for example. Thus one of the PWM signals 102,103,104 which are each at the same frequency as the approximation to a sine wave driving the loudspeaker 2 or the clock signal 101, is applied at digital input 202 for the microprocessor 110 to calculate the frequency of the approximation to a sine wave 105 as described earlier.

The analogue input 203 represents the amplitude of the signal being received by the microphone and is connected to microprocessor 110 via an external analogue to digital converter. The process of locating the resonant frequency is one of identifying the frequency at which the analogue input 203 is a maximum.

The process of locating the resonant frequency can be broken down into four stages. The first three stages S1, S2, S3 each involve changing the loudspeaker frequency to search for the resonance. When the resonance has been located, the final stage S4 measures the resonant frequency.

The first stage S1 is a fast scan through the permissible range of frequencies taking about one reading of the analogue input 203 for each step of the analogue output voltage 201. The permissible range of frequencies is selected to restrict the scan to those frequencies at which the non-radial resonance should occur for the expected combination of gas composition, temperature and pressure. The limits of the permissible range are imposed to reduce the time taken to locate the resonant frequency and also to reduce the risk of locating an unwanted resonant peak. Although the exact relationship between the control voltage from the analogue output 201 and the microphone frequency is not known, it can be approximated sufficiently well to be used to set the frequency limits of the permissible range within which to search for the resonance. In the present example the frequency range is 7.5kHz to 11.8Khz (4.3 kHz) with a frequency scan rate of 86 kHz/second and a microphone sampling rate of 100,000 samples/second producing a total of 5100 microphone samples in each direction.

To locate the resonance frequency the processor is arranged to look for a peak in the amplitude of a signal from the microphone at input 203 and then ascertain the frequency control voltage that was being used at the time.

To allow for the finite time the hardware takes to produce a change in the amplitude of the signal from the microphone at input 203 as a result of a change in the frequency control voltage at output 201, the fast scan of the first stage S1 involves a

first scan up through the range of analogue output voltages 201 and a second scan down through the same range of analogue output voltages. Clearly the first scan could alternatively be down through the range of analogue output voltages and the second scan could be up through the range. When scanning up, the frequency control voltage 201 being applied when the peak is detected will be, due to the response time, slightly higher than the voltage that caused the peak to occur. When scanning down, the frequency control voltage 201 will be slightly lower than the peak voltage. Assuming that the response time is the same for both scan directions, the average of the two voltages will give the true voltage at the resonance.

A second method of allowing for the finite response time of the hardware is shown in Fig.11 in conjunction with the above method of first and second scans in opposite directions. The second method uses an estimated value for the response time T to match the peak 301 of the received microphone data values M to the frequency control voltage V which, according to the estimated response time T and the characteristic of the frequency control voltage with time 302, produced that microphone data value as shown by the broken lines 303 in Figure 11. Consequently the microphone continues to collect data for a time after the frequency control voltage V has finished scanning at time t_1 . This second method enables peaks that lie near to the end of the scan limits such as peak 301 in the upward scan of frequency control voltage 302 in Figure 11 to be found which if the collection of microphone data M had been synchronised to the scanning of the

frequency control voltage 302 would have been missed. If the estimated response time was accurate, the values X,Y found for the voltages producing the resonant peak in each of the up and down scans would be exactly the same. However, as shown in Figure 11, the estimated value may be slightly inaccurate in which case the up and down values of the frequency control voltage will be slightly different and will then be averaged.

The second stage S2 uses the scanning method of the first stage except over a smaller frequency range, identified in the first stage as containing the resonant peak.

The second stage uses the value for the frequency control voltage at resonance obtained by the first stage as its centerpoint for its smaller frequency scan range. In this example the frequency scan range of the second stage is 150.5Hz.

However the result of the first scan may be too close to one of the end limits of the frequency control voltage range for the second stage to be able to use it as a centerpoint. In this case the scan of the second stage will be anchored at the appropriate end limit of the frequency control voltage range.

The frequency control voltage step size is also different for the second stage. For speed, the first stage does not use the full frequency control voltage resolution whereas the second stage does to produce a more precise resonance frequency value.

The second stage also uses a slower rate of change of loudspeaker frequency with time. In this case 2.15kHz/second rather than 86.0kHz/second used in the first stage. In this example the microphone sampling rate of the second stage is also lower at 25,000 samples/second producing a total of 1800 microphone samples.

The final value is obtained using the third stage S3 which uses a further scan which averages the microphone data and hence produces a dependable result. Like the second stage, this stage uses the result obtained by the preceding scan as its centerpoint. If the result of the second scan is too close to an end limit of the frequency control voltage range for the third stage S3 to be able to use it as a centerpoint, the third scan could be anchored at an appropriate end limit of its frequency control voltage range. However, the scan of this third stage is slower and more methodical than the scans of previous stages. Hence, it covers a range of fewer frequency control voltage values, generally 24 or less, and in this case 21. For each value the analogue output 201 is set and then the circuit is left to settle for a few milliseconds, in this case 5 milliseconds. When the settling time has elapsed, a given number of samples of the microphone voltage are taken, in this case 20, and summed. This process is repeated for each frequency control voltage value and the peak value ascertained. This is the resonant frequency control voltage value.

The final fourth stage S4 comprises holding the frequency at the resonant value and

WO 99/67629**PCT/GB99/01931**

measuring the frequency of the signal driving the loudspeaker 2 using a PWM signal 102,103,104 or clock signal 101 supplied to the digital input 202.

What is claimed is:

1. An apparatus for determining the speed of sound of a gas comprising:
 - a substantially spherical resonator for containing gas to be tested;
 - an acoustic transmitter for applying an acoustic signal to the interior of the resonator;
 - an acoustic receiver for detecting the amplitude of the acoustic signal in the interior of the resonator; and
 - control means for determining the speed of sound of a gas within the resonator from the frequency of a detected resonant mode;
 wherein the detected resonant mode is a non-radial resonant mode and the internal radius of the resonator is substantially 5 cm or less.
2. An apparatus according to claim 1, wherein the resonator has an internal radius of substantially 4 cm or less.
3. An apparatus according to claim 2, wherein the resonator has an internal radius of substantially 3 cm or less.
4. An apparatus according to claim 3, wherein the resonator has an internal radius of substantially 2 cm or less.
5. An apparatus according to claim 4, wherein the resonator has an internal radius of substantially 1.5 cm or less.
6. An apparatus according to claim 1, wherein the acoustic transmitter and receiver are arranged to be positioned outside the resonator cavity.
7. An apparatus according to claim 1, wherein the relative separation of the acoustic transmitter and receiver is variable.
8. An apparatus according to claim 7, wherein one of the acoustic transmitter and receiver is arranged to be mounted at a fixed distance from the centre of the resonator and the other is arranged to be mounted at a variable distance from the centre of the resonator.
9. An apparatus according to claim 1, wherein the acoustic transmitter is arranged to operate with a supply voltage of substantially 5 volts or less.
10. An apparatus according to claim 1, wherein the acoustic transmitter and receiver are arranged to be mounted to the resonator substantially 180° apart.
11. An apparatus according to claim 1, wherein the resonator has two or more passages through the wall of said resonator to enable gas to diffuse in and out during use.
12. An apparatus according to claim 1, wherein at least a portion of the resonator is made from a porous material.
13. An apparatus according to claim 1, wherein the control means is arranged to determine the speed of sound a gas within the resonator from the frequency of a detected non-radial resonant mode using the relation:

$$c=f \times K$$

where c is the speed of sound of a gas;

f is the measured resonant frequency; and

K is a constant for a resonator determined by calibration.

14. A method of determining the speed of sound of a gas comprising:

applying an acoustic signal by way of an acoustic transmitter to the interior of a substantially spherical resonator containing a gas the speed of the sound of which is to be determined;

detecting the amplitude by way of an acoustic receiver of the acoustic signal in the interior of the resonator; and

determining the speed of sound of a gas within the resonator from the frequency of a detected resonant mode;

wherein the detected resonant mode is a non-radial resonant mode and the internal radius of the resonator is substantially 5 cm or less.

15. A method according to claim 14, wherein the resonator has an internal radius of substantially 4 cm or less.

16. A method according to claim 15, wherein the resonator has an internal radius of substantially 3 cm or less.

17. A method according to claim 16, wherein the resonator has an internal radius of substantially 2 cm or less.

18. A method according to claim 17, wherein the resonator has an internal radius of substantially 1.5 cm or less.

19. A method according to claim 14, wherein the acoustic transmitter and receiver are arranged to be positioned outside the resonator cavity.

20. A method according to claim 14, wherein the relative separation of the acoustic transmitter and receiver is variable.

21. A method according to claim 20, wherein one of the acoustic transmitter and receiver is arranged to be mounted at a fixed distance from the centre of the resonator and the other is arranged to be mounted at a variable distance from the centre of the resonator.

22. A method according to claim 14, wherein the acoustic transmitter is arranged to operate with a supply voltage of substantially 5 volts or less.

23. A method according to claim 14, wherein the acoustic transmitter and receiver are arranged to be mounted to the resonator substantially 180° apart.

24. A method according to claim 14, wherein the resonator has two or more passages through the wall of said resonator to enable gas to diffuse in and out during use.

25. A method according to claim 14, wherein the resonator is made from porous material.

26. A method according to claim 14, wherein the speed of sound of a gas within the resonator is determined from the frequency of a detected non-radial resonant mode using the relation:

$$c=f \times K$$

where c is the speed of sound of a gas;

f is the measured resonant mode; and

K is a constant for a resonator determined by calibration.

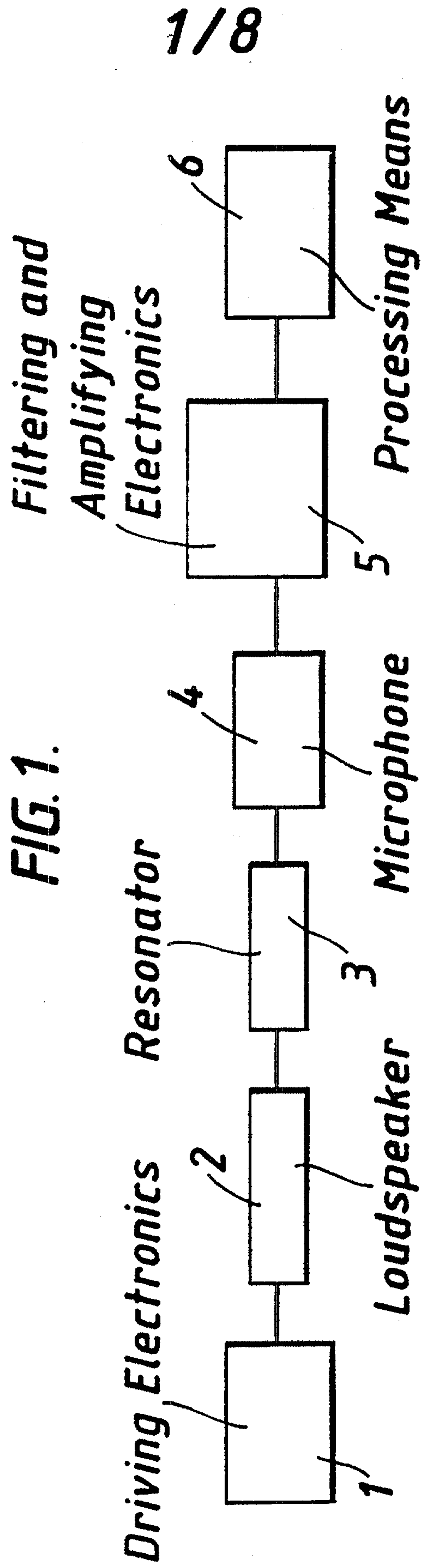

2/8

FIG. 2.

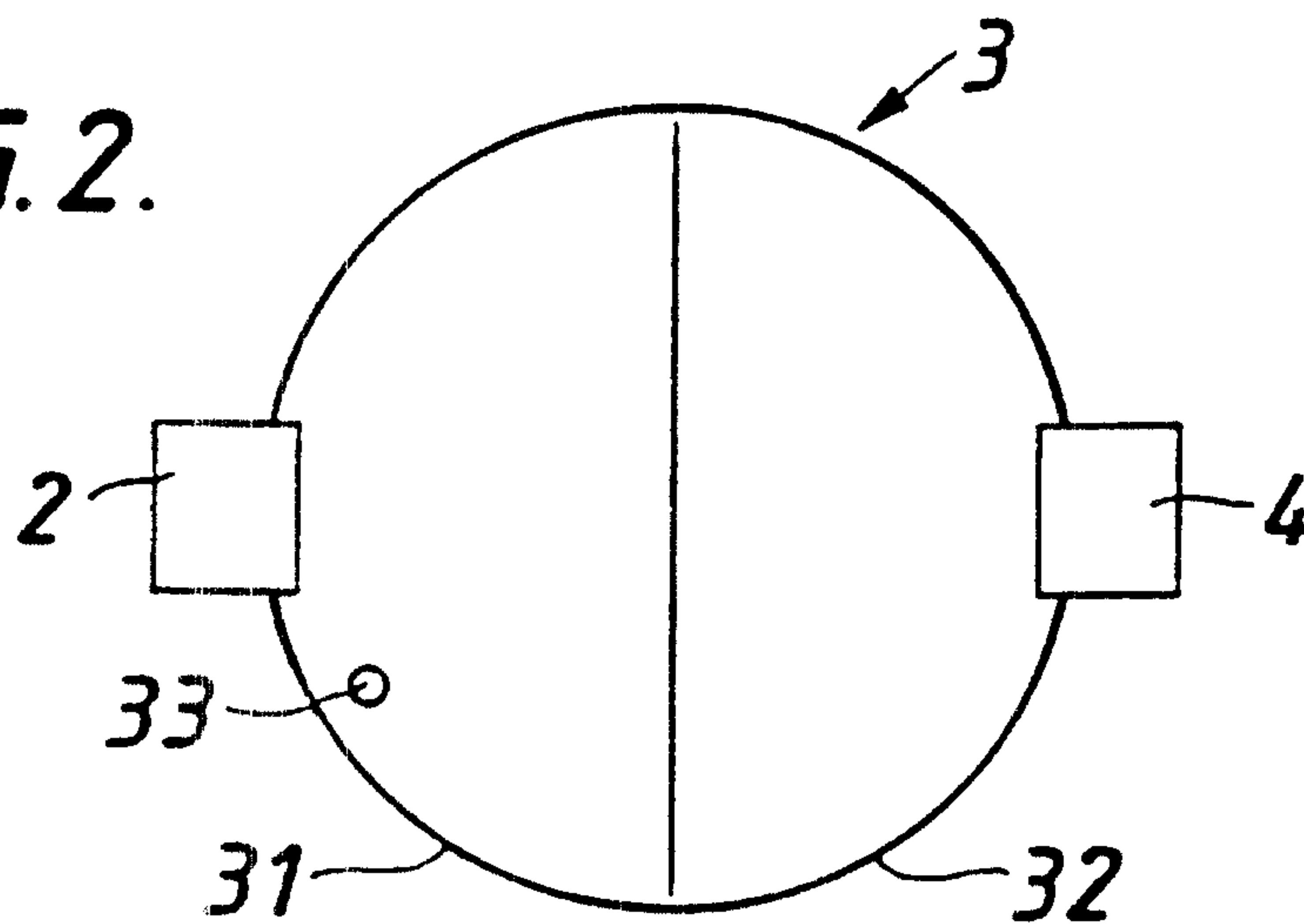

FIG. 3.

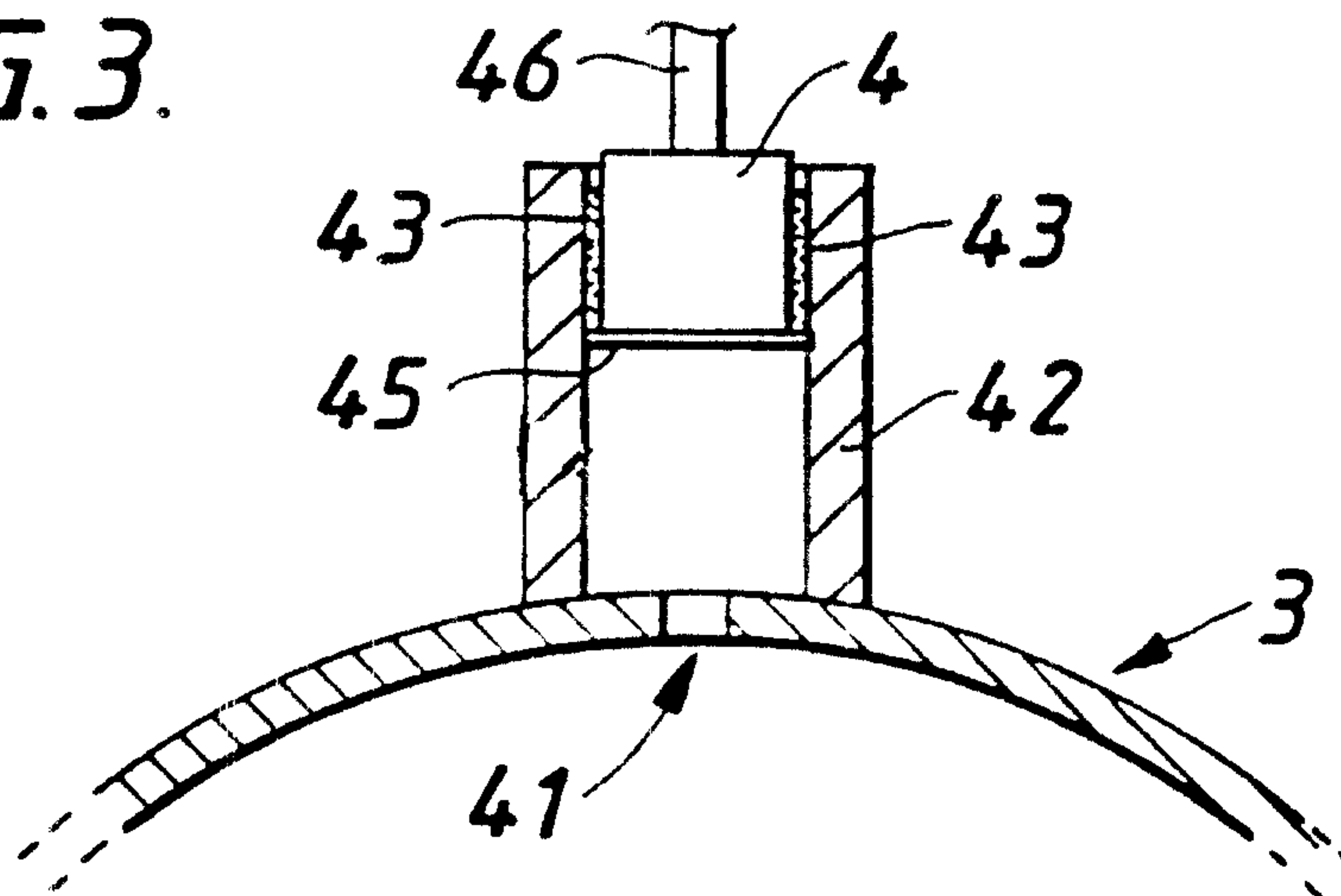
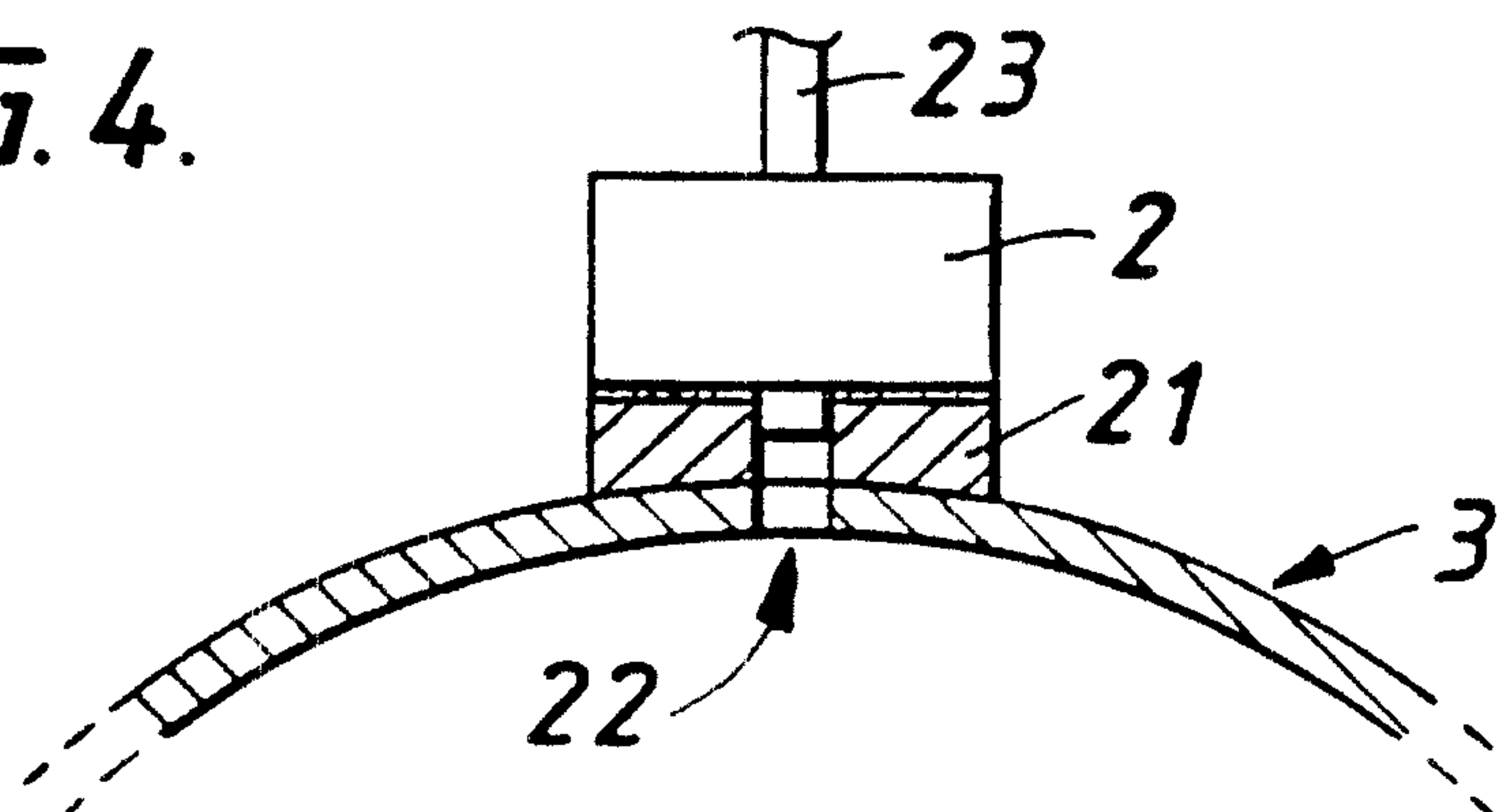
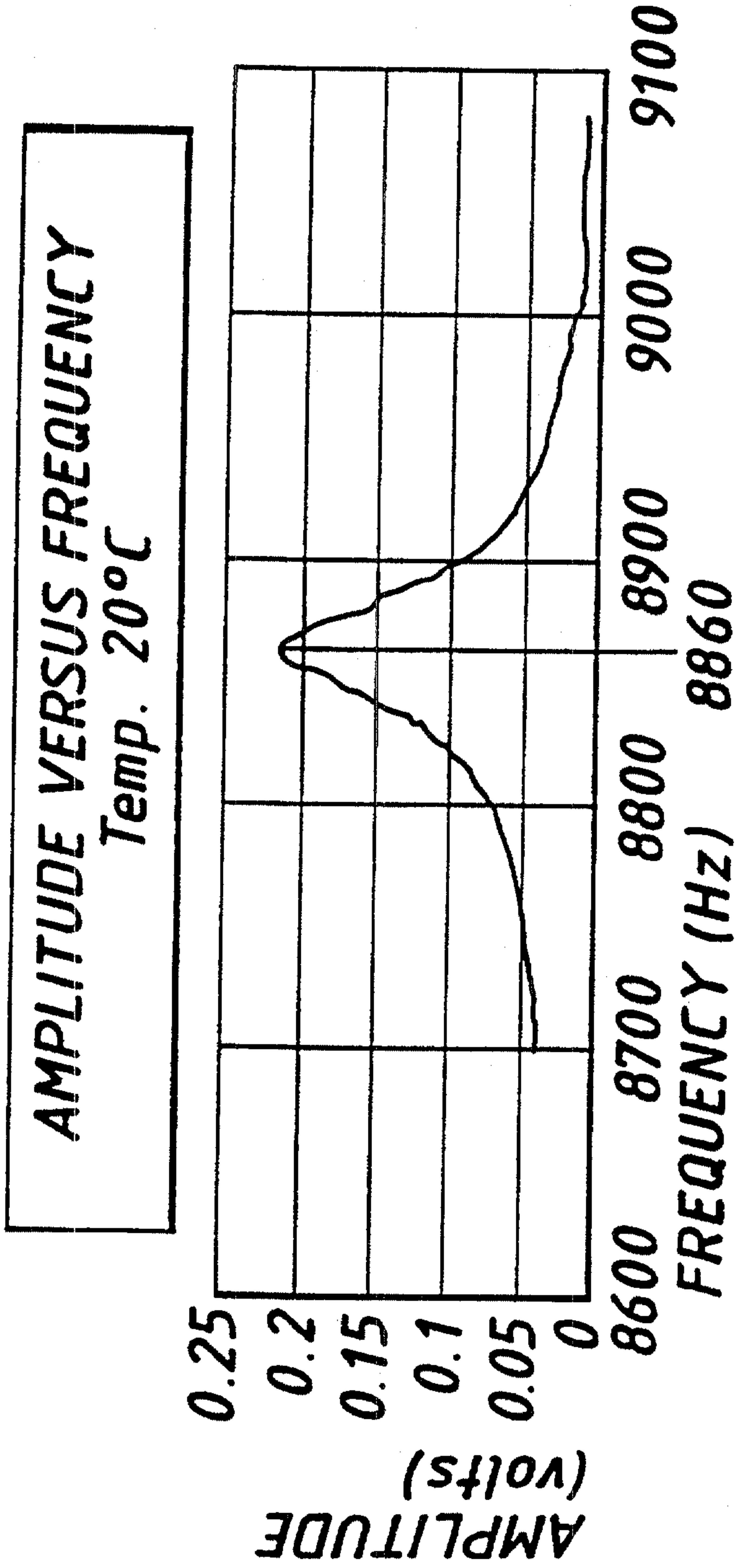

FIG. 4.



3/8

FIG. 5.



4/8

FIG. 6.

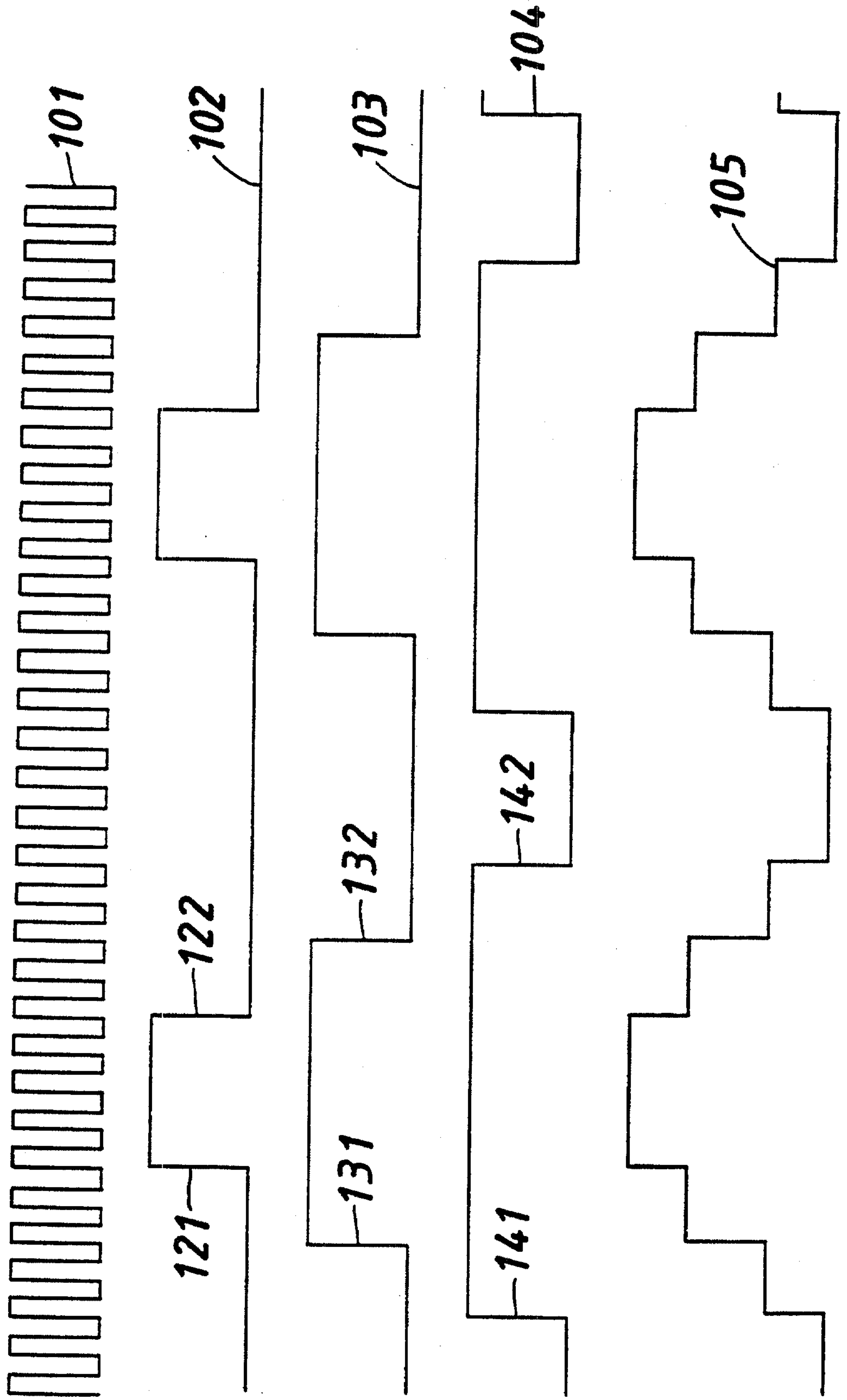

5/8

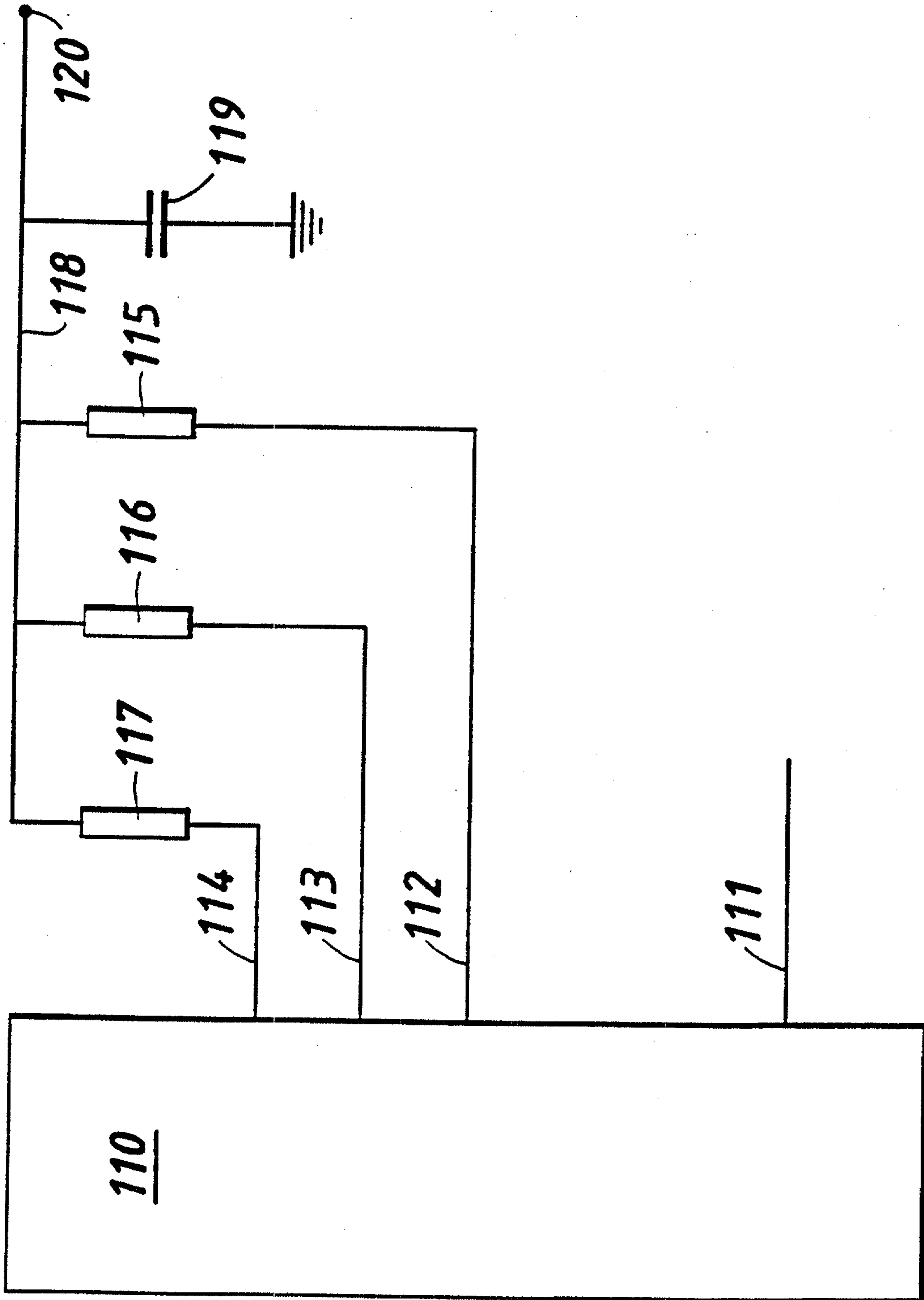
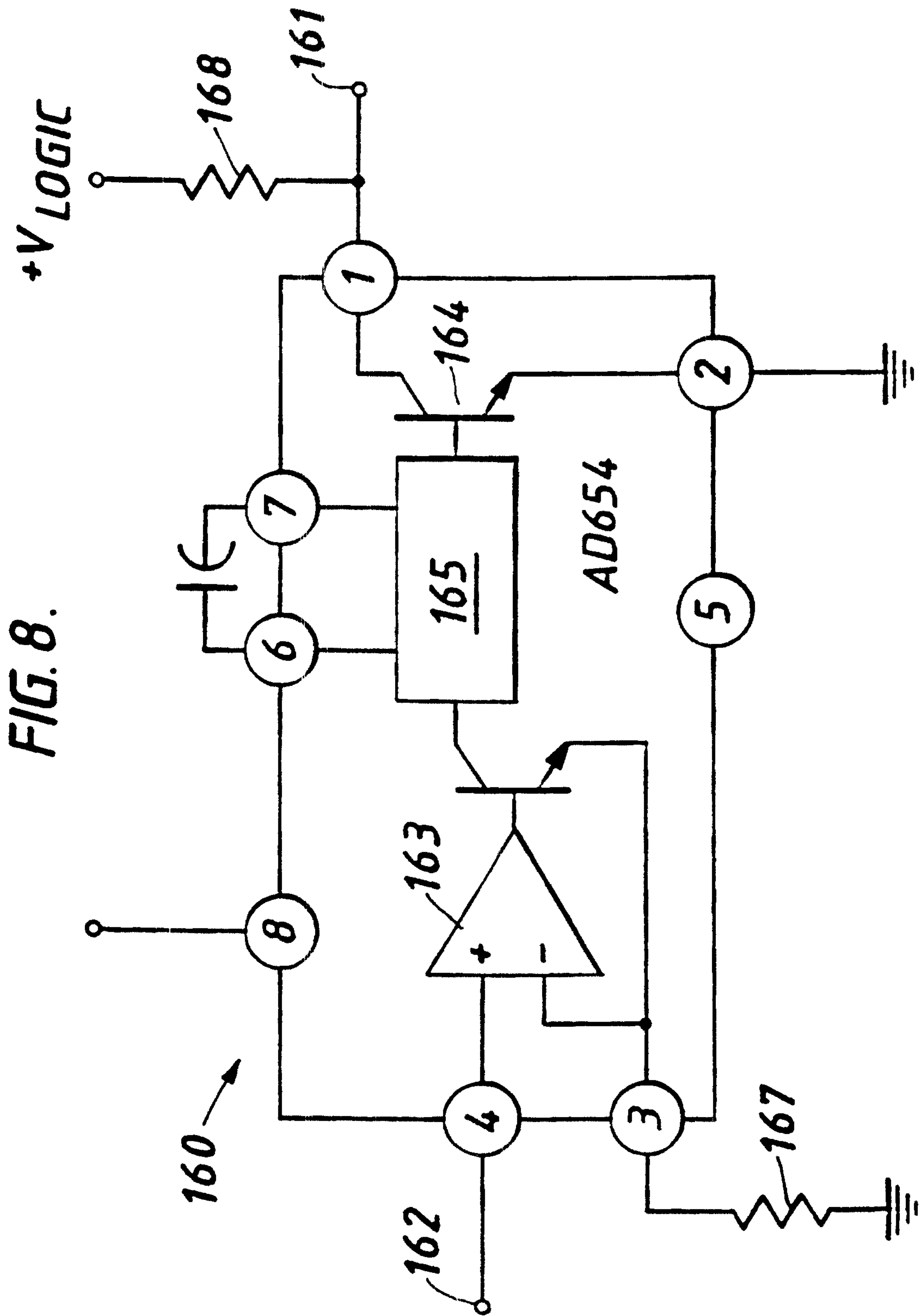

FIG. 7.

6/8



7/8

FIG. 9.

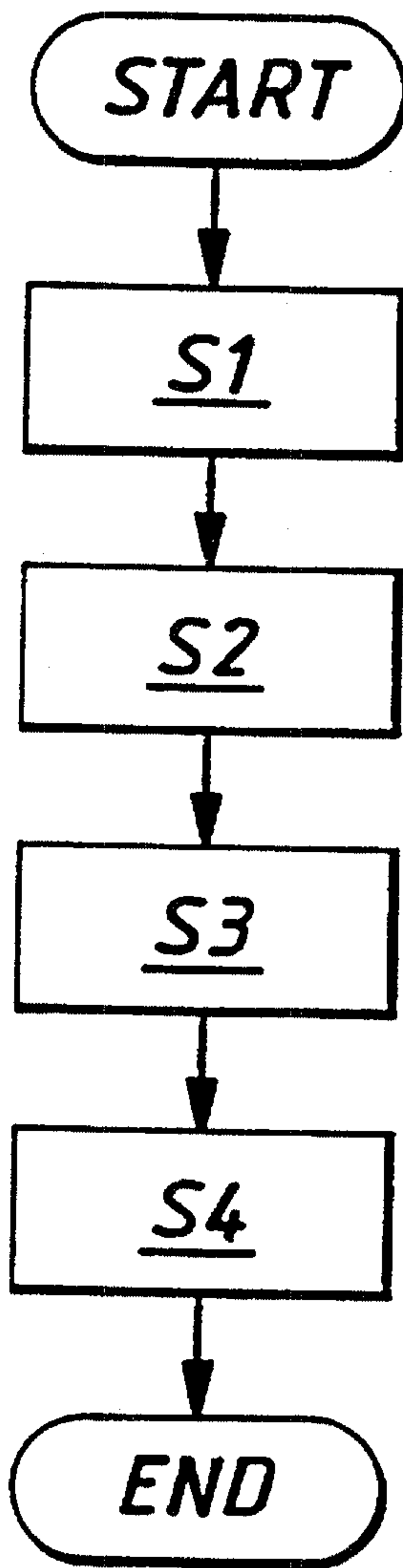
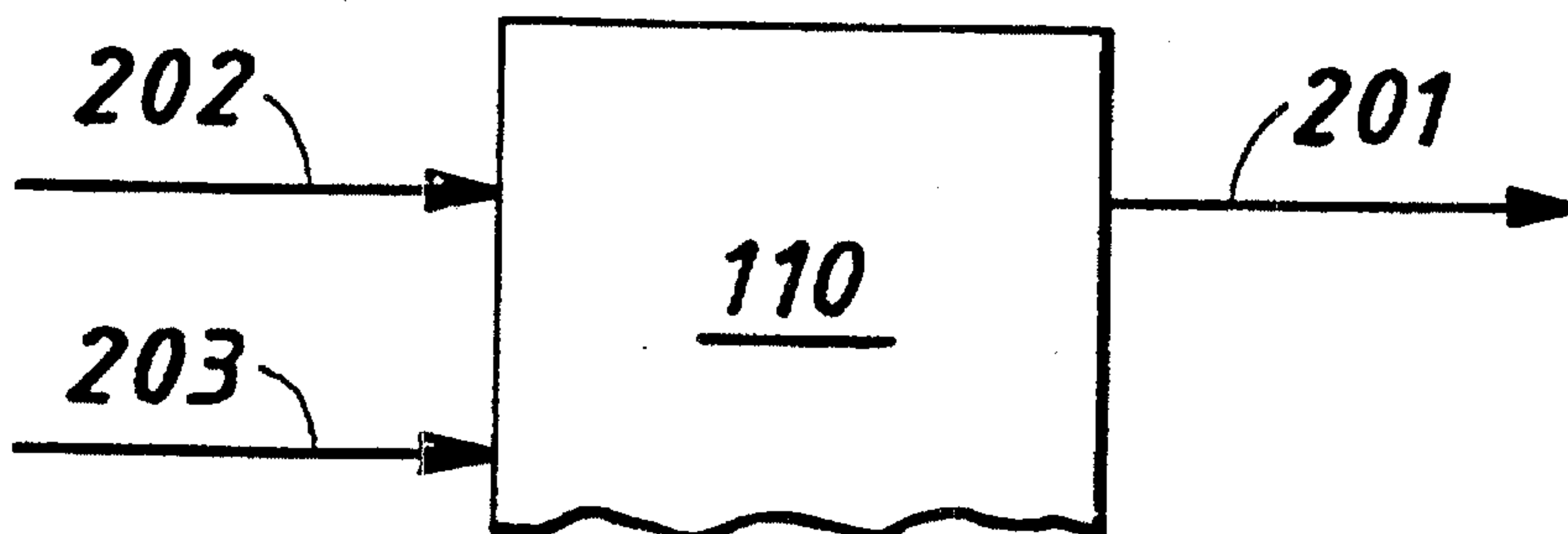

FIG. 10.



8/8
FIG. 11.

