

(No Model.)

2 Sheets—Sheet 1.

C. M. LETZ.

MACHINE FOR MAKING WAX FORMS FOR ELECTROTYPING.

No. 524,765.

Patented Aug. 21, 1894.

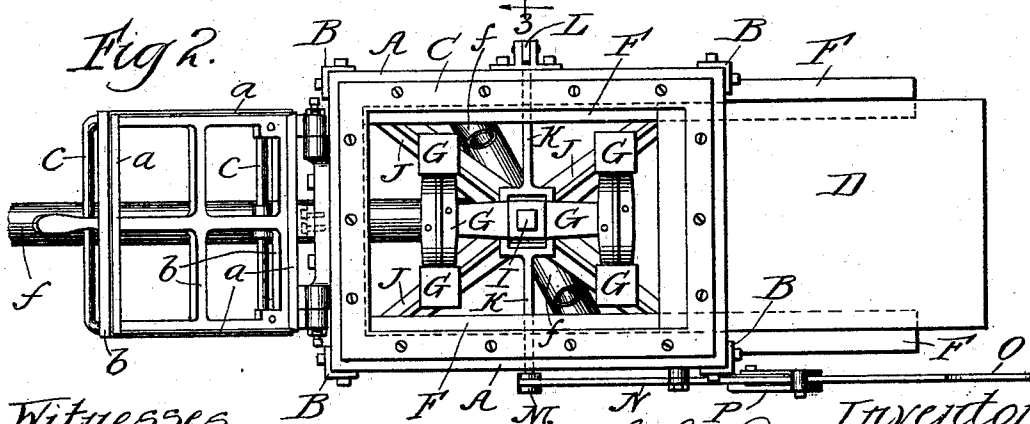
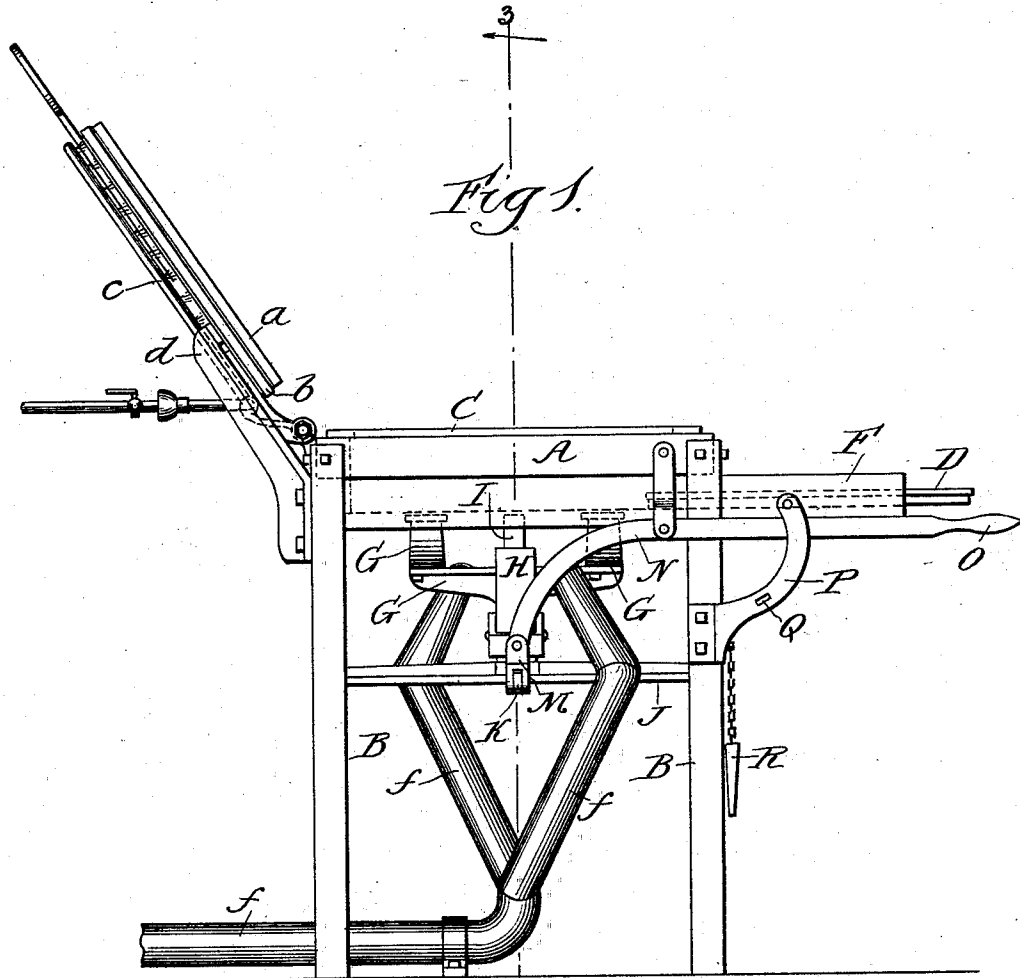

Witnesses
 Wm. J. Fleming
 M. E. Shields

Inventor
 Chas. M. Letz
 by Raymond & Oushinsky
 Attys.

C. M. LETZ.

MACHINE FOR MAKING WAX FORMS FOR ELECTROTYPING.

No. 524,765.

Patented Aug. 21, 1894.

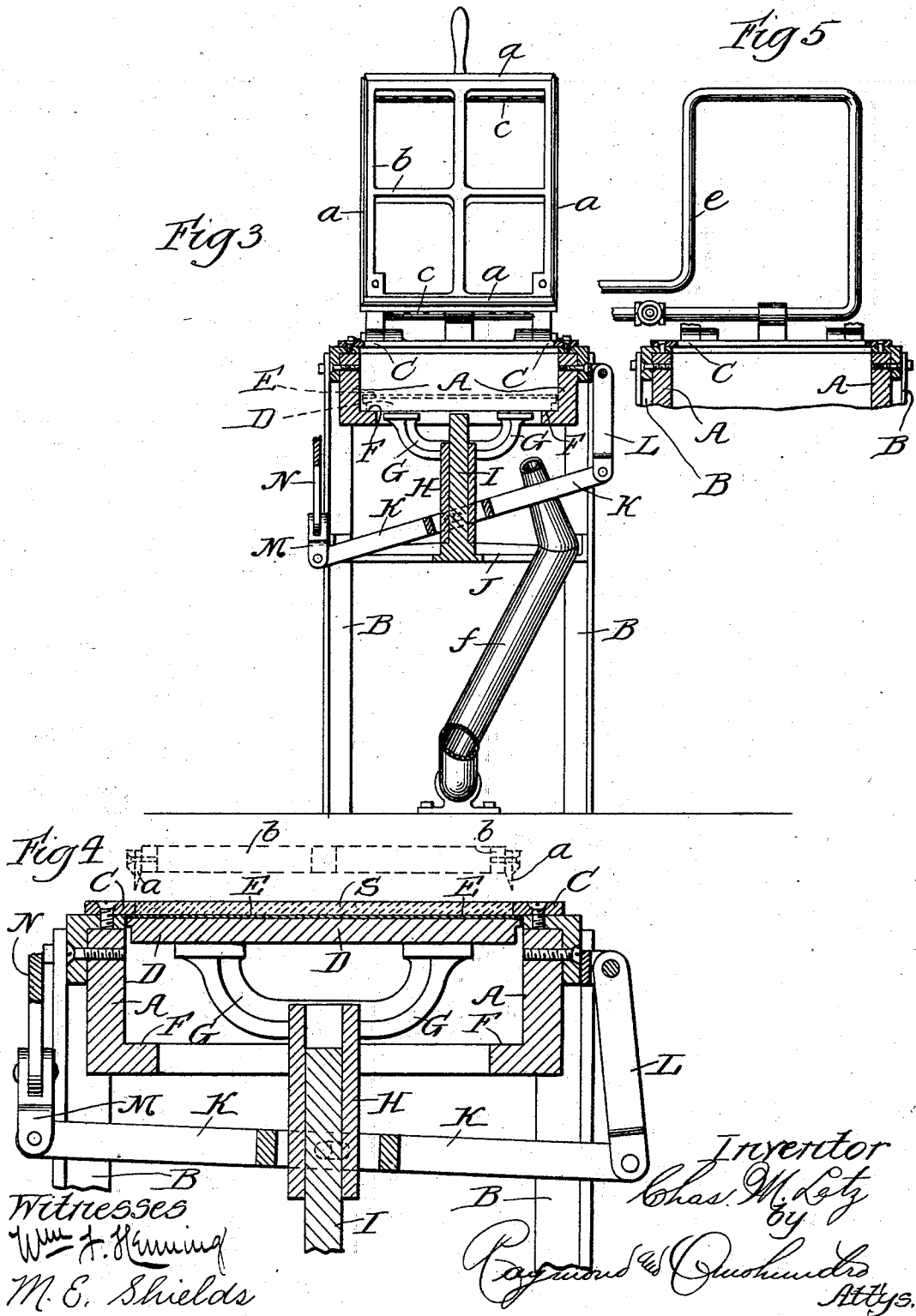

Witnesses
 Wm. F. Hummel
 M. E. Shields

Inventor
 Chas. M. Letz
 by
 Raymond & Quinlan
 Attys.

UNITED STATES PATENT OFFICE.

CHARLES M. LETZ, OF CHICAGO, ILLINOIS, ASSIGNOR TO THE FRANKLIN ENGRAVING AND ELECTROTYPING COMPANY, OF SAME PLACE.

MACHINE FOR MAKING WAX FORMS FOR ELECTROTYPING.

SPECIFICATION forming part of Letters Patent No. 524,765, dated August 21, 1894.

Application filed April 30, 1894. Serial No. 509,499. (No model.)

To all whom it may concern:

Be it known that I, CHARLES M. LETZ, a citizen of the United States, residing in Chicago, county of Cook, and State of Illinois, have invented certain new and useful Improvements in Machines for Making Wax Forms for Electrotyping, of which the following is a full, clear, and exact description, reference being had to the accompanying drawings, forming a part of this specification.

In the art of electrotyping it has been, for many years, the common practice to use what is technically called a form, consisting of a base-plate of comparatively thin sheet copper, or electrotyper's or other metal, about one-eighth of an inch thick, with a coating of wax about one-quarter of an inch thick on one side thereof, in which wax is made, by a power-press, the impression of a wood or photo-mechanical engraving or electrotype, of which it is desired to make an electrotype, the impression in the wax being used to receive the electro-deposition of copper forming the face or printing surface of the electrotype to be produced therefrom.

Prior to this invention, so far as I am aware, it has been the almost universal practice to make these forms by first placing the base-plate upon a stone or metallic bed-plate, then laying upon the base-plate or bed-plate a metallic frame corresponding in shape and dimensions with the base-plate, and rising above the edges thereof a sufficient distance to retain a coating of melted wax when poured upon the base-plate to the desired depth or thickness of coating required upon the plate. The practice of this portion of the art is necessarily slow, and more or less inaccurate, besides being objectionable in many respects. For instance, the comparatively thin base-plates become bent and warped in use and handling, and must necessarily be first straightened or flattened by hammering, next it is absolutely necessary that the outer edges of the frames, resting upon the base or bed-plate, must be banked on all sides with cold or stiff wax in order to hold the melted wax within the frame, as such frames become bent and warped in use, and do not make sufficiently close contact with the base-plate or bed-plate to prevent the melted wax from

running out underneath the frame. These objections greatly increase the cost of making the forms, many of which are spoiled in trimming off the banking wax and overflow portions, and must therefore be scraped off and remelted, besides producing plates of varying degrees of perfection, frequently involving loss of time and material in other portions of the electrotyping process and annoying delays where rapid work is required.

The prime object of this invention is to avoid all of these objectionable features, and particularly the hammering out of bent plates, the banking of the frames and hand trimming of the banking and overflow wax, whereby the manufacture of the forms is greatly cheapened and facilitated, and a more perfect and uniform product is produced.

Other objects are to promote the rapid cooling of the wax in the making of the form and to dispense with the employment of detachable or portable frames, and thereby avoid the leakage and banking resulting from their use.

These and other objects, which will appear farther on, are obtained by the devices illustrated in the accompanying drawings, in which—

Figure 1 represents a side elevation of a machine embodying my invention. Fig. 2 represents a plan view thereof; Fig. 3, a transverse vertical section on the line 3—3 of Fig. 1, looking in the direction indicated by the arrow; Fig. 4, an enlarged detail section on the line 3—3 of Fig. 1, looking in the opposite direction from that in which Fig. 3 is taken; and Fig. 5 represents a modified form of the heating device for the cutter.

Similar letters of reference indicate the same parts in the several figures of the drawings.

Referring by letter to the accompanying drawings, A indicates a hollow, metallic, rectangular frame supported upon suitable legs, and provided at the top thereof with an overhanging flange, C, which projects inwardly beyond the inner edge of the frame, a sufficient distance to offer a firm resistance to a vertically movable bed-plate, D, between which and the said overhanging flange is clamped the edges of the base-plate, E, of

the wax form, as more clearly illustrated in Figs. 3 and 4.

Along the lower side edges of the frame, A, is provided a pair of ledges or guides, F, which project a suitable distance beyond the front of the frame, A, and upon which the bed-plate, D, normally rests, said guide ledges affording a convenient means for supporting the bed-plate, which is composed of metal and is of considerable weight, while the latter is being moved into and out of operative position, in inserting the base-plates, E, in position in the form, and removing the completed form from the machine.

It will be noted that the position of the bed-plate upon this ledge is somewhat below the overhanging flange, C, at the top of the frame, such difference in position being necessary in inserting the base-plate in position and removing the completed form from the machine. To this end I propose to have the bed-plate, D, after it is moved horizontally to a central position in the frame, A, moved vertically by some suitable mechanism until the base-plate, resting thereon, is firmly clamped at its side edges between the bed-plate, D, and the overhanging flange, C, at the top of the frame. Simple and effective mechanism for accomplishing this result is illustrated in the drawings, consisting of the arms, G, secured in any suitable manner to the sleeve or hub, H, which latter is guided upon a rigid stem, I, supported by a frame, J, of any suitable kind attached to the legs of the machine, the sleeve and stem preferably being square to prevent rotation of the sleeve and the arms carried thereby.

Attached at its center to the sleeve, H, by a pin and slot connection is a lever, K, one end of which is pivotally connected with one end of a link, L, pivotally hung at its opposite end from the frame, A, while the other end of the lever, K, is pivotally connected by a link, M, with an operating lever, N, pivoted to the side of the frame, A, and terminating in a handle-end, O, for convenience of manipulation. The handle-end of the lever, N, works in a suitable guide, P, which is provided with transverse holes or perforations, Q, for the reception of a lock-pin, R, which is inserted after the lever is depressed to the limit of its downward stroke so as to lock the lever in such position. Thus it will be observed that with the parts in the position shown in Fig. 1, with the bed-plate, D, drawn out to the front of the machine, a base-plate, E, is laid thereon and the bed-plate is then shoved into a central position within the frame, A, above the ends of the arms, G, which terminate in flattened portions to better support said plate. The handle-end of the lever, N, is then depressed, causing a corresponding elevation of the arm, G, carrying with them the bed-plate, D, and base-plate, E, until the latter is firmly clamped between the bed-plate and the overhanging flanges, C, when the lever, N, is locked in position by the pin,

R, as before described. The base-plate is now in position to receive the coating of wax, the overhanging flanges, C, serving as rails, the equivalent of the rectangular frames of the old art, to measure the depth or thickness of the coating of wax and retain the same in place while cooling, the coating of wax being shown at S in Fig. 4.

As soon as the wax is sufficiently cooled and set, the lever, N, is released and the arms, G, carrying the bed-plate fall back to their normal position, but the adhesion of the wax to the surrounding metal is such that the base-plate remains suspended and the wax must be severed from the surrounding metal, either by a knife run around the inner edge of the flange, C, or in some other manner, before the complete form can be removed from the machine. A convenient and important device for accomplishing this result is the rectangular cutter shown in the drawings, and particularly in dotted lines in Fig. 4, consisting of a series of knives, *a*, secured to a rectangular frame, *b*, which latter is hinged at its lower edge to the rear edge of the frame, A, so that it may be thrown up and back out of the way, as illustrated in Figs. 1, 2 and 3, or may be swung down into operative position, so as to sever the wax from the flange, C, on all sides at a single stroke, the cutting knives, *a*, extending all around the frame and being arranged to exactly fit within the said flanges.

The force of the contact, when the cutter is permitted to drop, severs the wax from the flanges and knocks the bed-plate with its coating of wax free, permitting it to drop down on to the bed-plate, D, with which it is drawn out of the front side of the machine and removed for use. With a cutter of this kind, in order to prevent adhesion between the cutter and the wax, it is desirable to keep the cutter in a constantly warm condition and this may be accomplished in any suitable manner, such, for instance, as by the gas-burner, *c*, consisting of a piece of gas-pipe perforated and arranged in a rectangular form, corresponding in dimensions with the frame of the cutter and arranged so that when the cutter is thrown up and resting on the stop, *d*, on the frame of the machine, the jets of flame from the burner will strike against the frame of the cutter and thus keep the frame warm.

Another form of heater is that shown in Fig. 5 consisting of the steam-pipe, *e*, bent to rectangular form and corresponding in dimensions and location with the gas-burner.

Still other means of heating the frame will readily suggest themselves to one skilled in the art, and need not be illustrated or described herein.

I also propose to facilitate or promote the cooling of the wax upon the base-plate by directing thereon a gentle blast of air by means of the pipes, *f*, directed against the bottom of the bed-plate, D, and which conduct air from any suitable source of supply, and in

such quantities and at such temperature as practice may prove necessary to promote the most desirable results, without danger of too sudden or unequal cooling of the wax.

5 The broad idea of my invention is a stationary frame, meaning to include in such term the overhanging flanges, C, and the movable bed-plate, regardless of the particular mechanism by which the bed-plate is operated or the manner in which it is moved to and fro, and in a more limited sense my invention consists in the combination with the stationary frame and movable bed-plate of a movable cutter, whether heated or not, and regardless of how heated or in what manner it moves to perform its function, and therefore I do not desire to limit myself to the particular devices or combination of devices herein shown and described.

20 Having described my invention, what I claim and desire to secure by Letters Patent, is—

1. In a machine for making wax forms for electrotyping, the combination with an open frame of a movable bed-plate of greater dimensions than the opening in the frame and means for causing said bed-plate to approach and recede from the opening in said frame, substantially as and for the purpose described.

30 2. In a machine for making wax forms for electrotyping, the combination with an open rectangular frame of an overhanging flange around the upper part thereof, a bed-plate adapted and arranged to work within said frame and to oppose the outer side of said flange, guide-ledges on said frame in a plane below said flange, and upon which the bed-plate rests, and means for lifting said bed-plate from the guide-ledges, substantially as and for the purpose described.

40 3. In a machine for making wax forms for electrotyping, the combination with an open rectangular frame of an overhanging flange around the upper edge thereof, of a bed-plate adapted and arranged to move horizontally and vertically within said frame, guide-ledges on said frame upon which the bed-plate normally rests, arms adapted and arranged to move said bed-plate vertically, a separable connection between said arms and plate, and means for operating the arms substantially as described.

55 4. In a machine for making wax forms for electrotyping, the combination with an open rectangular frame and an overhanging flange at the upper edge thereof, of a bed-plate adapted and arranged to move horizontally and vertically within said frame, guide-ledges for supporting said frame in a plane below the overhanging flange, arms for moving said bed-plate vertically, a separable connection

between said arms and bed-plate and a system of levers for actuating said arms, substantially as and for the purpose described.

65 5. In a machine for making wax forms for electrotyping, the combination with an open rectangular frame and an overhanging flange around the upper edge thereof, of a bed-plate adapted and arranged to move horizontally and vertically within said frame, means for moving said plate vertically and means for directing a blast of air against the under side of said plate, substantially as and for the purpose described.

75 6. In a machine for making wax forms for electrotyping, the combination with an open rectangular frame of a movable bed-plate of greater dimensions than the opening in the frame and a movable cutter adapted and arranged to work through the opening in said frame, substantially as and for the purpose described.

85 7. In a machine for making wax forms for electrotyping, the combination with an open rectangular frame of a bed-plate of greater dimensions than the opening in said frame, a movable cutter adapted and arranged to move through the opening in said frame, and means for heating said cutter, substantially as and for the purpose described.

90 8. In a machine for making wax forms for electrotyping, the combination with an open rectangular frame, an overhanging flange around the upper edge thereof, a bed-plate adapted and arranged to move horizontally and vertically within said frame, and means for moving said plate vertically, of a rectangular frame having knives adapted and arranged to work within the flange of said frame, said cutter frame being hinged to the first-mentioned frame at the edge thereof, a stop for said cutter-frame, and means for heating said frame while resting against said stop, substantially as and for the purpose described.

105 9. In a machine for making wax forms for electrotyping, the combination with an open rectangular frame an overhanging flange around the upper edge thereof, a bed-plate adapted and arranged to move horizontally and vertically within said frame, and means for moving said plate vertically, of a movable cutter having knives arranged to work within said flanges, means for heating said cutter when out of operative position and means for directing a blast of air upon the bottom of said base-plate, substantially as and for the purpose described.

CHARLES M. LETZ.

Witnesses:

M. E. SHIELDS,
CHAS. B. BOWEN.