

Baker & Harbster,
Rotary Measuring Faucets,
No. 68,546, *Patented Sept. 3, 1867.*

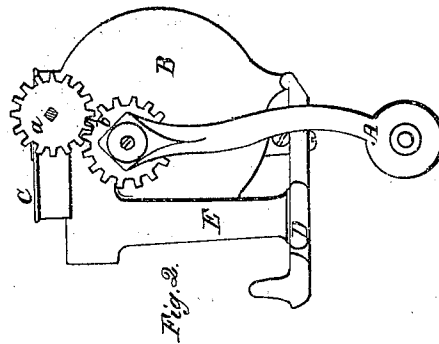
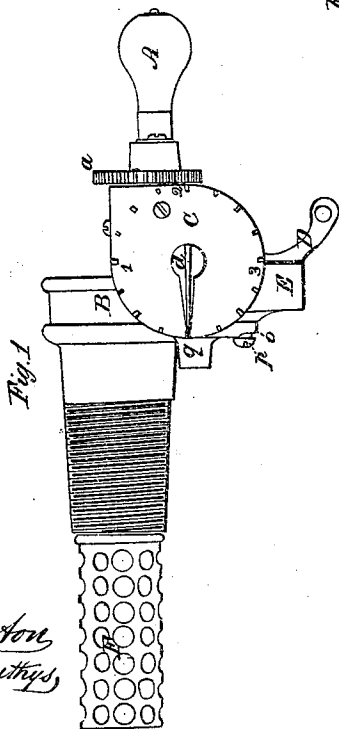
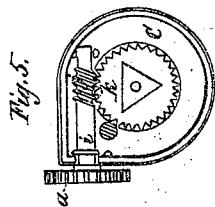
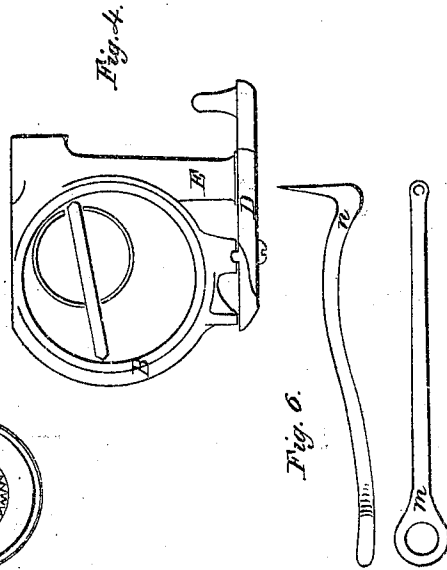
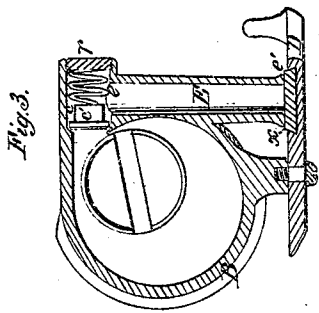

Witnesses.
V. Clayton,
John Matthews,

Inventors.
John G. Baker &
Wm. Harbster,
by atty, J. Clayton

United States Patent Office.

JOHN G. BAKER, OF PHILADELPHIA, AND WILLIAM HARBSTER, OF READING, PENNSYLVANIA, ASSIGNORS TO THE "ENTERPRISE MANUFACTURING COMPANY," OF PENNSYLVANIA.

Letters Patent No. 68,546, dated September 3, 1867.

IMPROVEMENT IN ROTARY MEASURING-FAUCETS.

The Schedule referred to in these Letters Patent and making part of the same.

TO ALL WHOM IT MAY CONCERN:

Be it known that we, JOHN G. BAKER, of Philadelphia, in the county of Philadelphia, and WILLIAM HARBSTER, of Reading, in the county of Berks, all in the State of Pennsylvania, have invented certain new and useful "Improvements in Measuring-Faucets;" and we do hereby declare that the following is a full, clear, and exact description thereof, reference being had to the accompanying drawings, forming a part of this specification.

Our invention consists in certain improvements upon the "rotatory measuring-faucets" for which patents were granted to Ira Kinman, May 13, 1859, and to John G. Baker, July 10, 1866. Careful experiments showed that faucets constructed according to those patents varied the quantities measured by them in proportion to the varying density of the fluid measured; that one of those faucets, so gauged as to measure an exact gallon of thick sirup by a given number of turns of the crank, would measure a much larger quantity of a thinner sirup with the same number of turns. This invention is intended more particularly to obviate this defect, which is accomplished by the valve device hereinafter described. Our invention also consists in the addition to the inlet pipe of a sheet-metal strainer, to prevent the entrance of obstructions into the faucet. In the drawings—

Figure 1 is a plan view.

Figure 2 is a front elevation.

Figure 3 is a vertical section through the gate, valve-chamber, revolving cylinder, and eccentric-chamber.

Figure 4 is a section through the eccentric-chamber, revolving cylinder, and rotating slide.

Figure 5 is a section through the dial-box, with dial removed.

Figure 6 shows the front and side of the hook for steadying the faucet in the barrel.

To enable others skilled in the art to make and use our invention, we will proceed to describe its construction and operation.

In fig. 1, A represents the operating crank; A', the inlet pipe, which is screwed into the barrel or other vessel; B, the eccentric-chamber; C, dial-plate; d, dial-hand; D, gate; E, the discharge pipe; F, the strainer; a, gearing by which the dial-hand is revolved. In fig. 2 the same letters represent like parts as in fig. 1; b, the gear-wheel on the crank-shaft; E is the discharge pipe. In fig. 3 is the device for pumping, which is like the one used in the patented rotatory measuring-faucets referred to above; e is the valve opening; e', the valve; e is the spring; r is the screw for holding the valve and spring in their proper places; e' is the packing of gate D. In fig. 4, like letters designate like parts as in fig. 3. a, fig. 5, is the gear-wheel for turning shaft i; j, worm-screw on shaft i; k, bevel gear-wheel for turning the dial-hand d; C is the chamber of the dial gearing and dial-plate. In fig. 6, the hook is shown in a plan view at m, and a side elevation at n.

In the operation of my invention, the general operation of it is the same, as regards the pump and dial, as the patents hereinbefore mentioned; but, in addition thereto, the strainer F is inserted in the end of the inlet pipe, and serves as a guard to the faucet, and, being made of thin sheet metal, readily admits thicker fluids through it than if made otherwise, as its area is larger. The liquid passing through this strainer is, by a revolution of the rotatory slide, forced up to the valve e', and presses against and opens a passage, through which the liquid runs into outlet pipe E, out at the gate D, (which had previous to this been opened,) into the vessel placed to receive it. As soon as the rotatory slide passes the valve, the spring throws the valve back to its seat and cuts off the flow of the liquid, so that the liquid cannot run out from the faucet, even if by inadvertence the gate D should be left open. In fig. 1, the lug o, attached to the body of the faucet, and set-screw P, are to prevent the turning of the screw, and to keep the parts of the faucet firmly together in removing it from the vessel. The lug q, to which is attached the hook m, is to keep the faucet from turning round while in the vessel in the act of drawing the fluid. This hook is attached, after the faucet is inserted into the vessel, by placing the end with the mortise over the lug q, and driving the hook into the vessel containing the liquid to be drawn. The gate D is cast with a dove-tailed opening, x, of suitable diameter and depth, to receive and retain a piece of rubber packing, (e', fig. 3,) which is hammered down into the aforesaid opening.

Having thus fully described our invention, what we claim as new, and desire to secure by Letters Patent, is—

The valve e', constructed and operating substantially as described, in combination with the rotatory measuring-faucet.

In testimony that we claim the above-described "improvements in rotatory measuring-faucets," we have hereunto signed our hands this 4th day of December, 1866.

JOHN G. BAKER,
WILLIAM HARBSTER.

Witnesses:

PETER CLEAVER,
JERE. H. BOONE.