

Feb. 6, 1962

M. O. ROSS  
DISPENSING DEVICE

3,019,629

Filed May 4, 1959

4 Sheets-Sheet 1

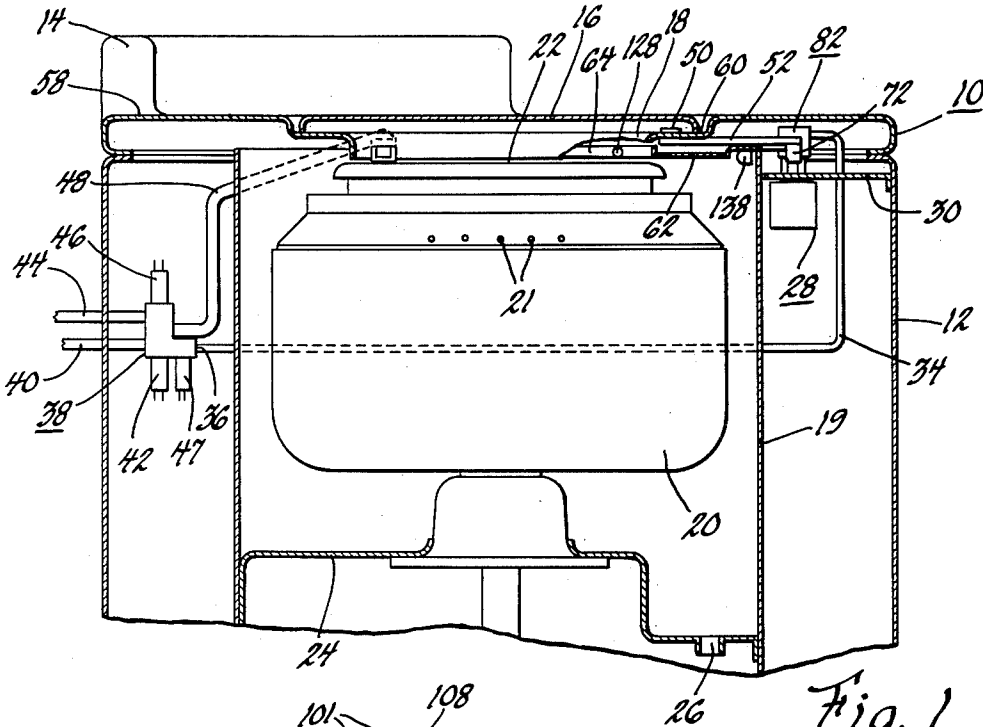

Fig. 1

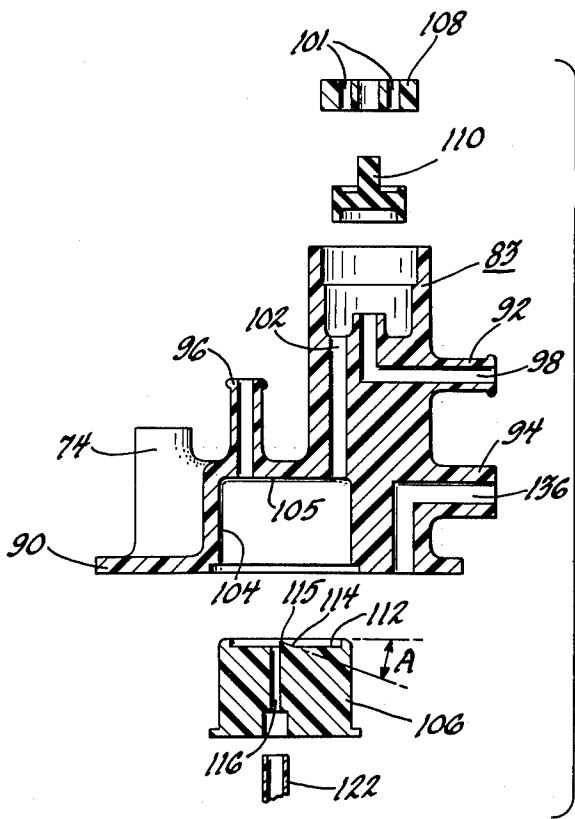

Fig. 5

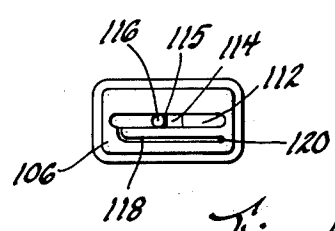

Fig. 4

INVENTOR.  
Marvin O. Ross  
BY Frederick M. Ritchie  
HIS ATTORNEY

Feb. 6, 1962

M. O. ROSS  
DISPENSING DEVICE

3,019,629

Filed May 4, 1959

4 Sheets-Sheet 2

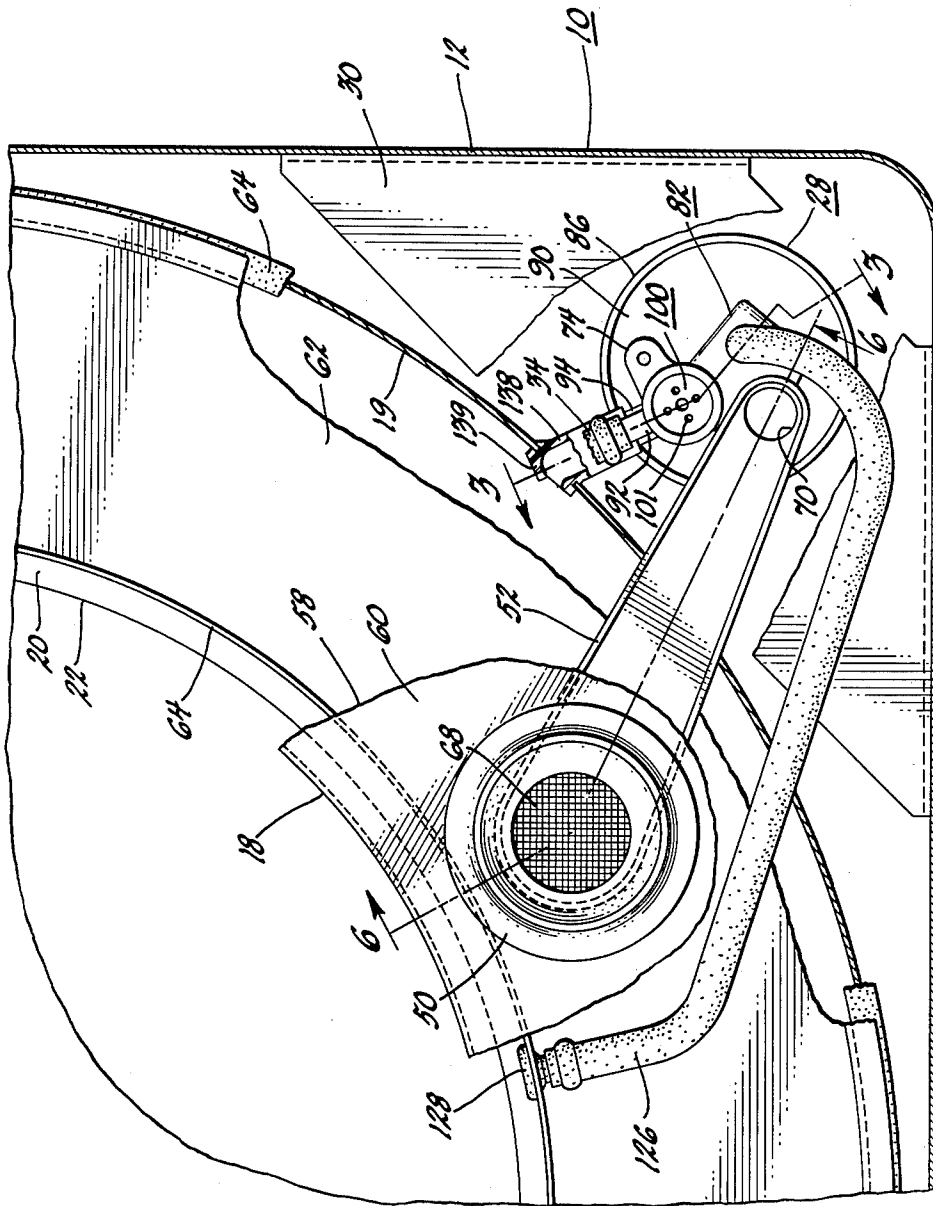

Fig. 2

INVENTOR.  
Marvin O. Ross  
BY  
Frederick M. Ritchie  
HIS ATTORNEY

Feb. 6, 1962

M. O. ROSS

3,019,629

DISPENSING DEVICE

Filed May 4, 1959

4 Sheets-Sheet 3

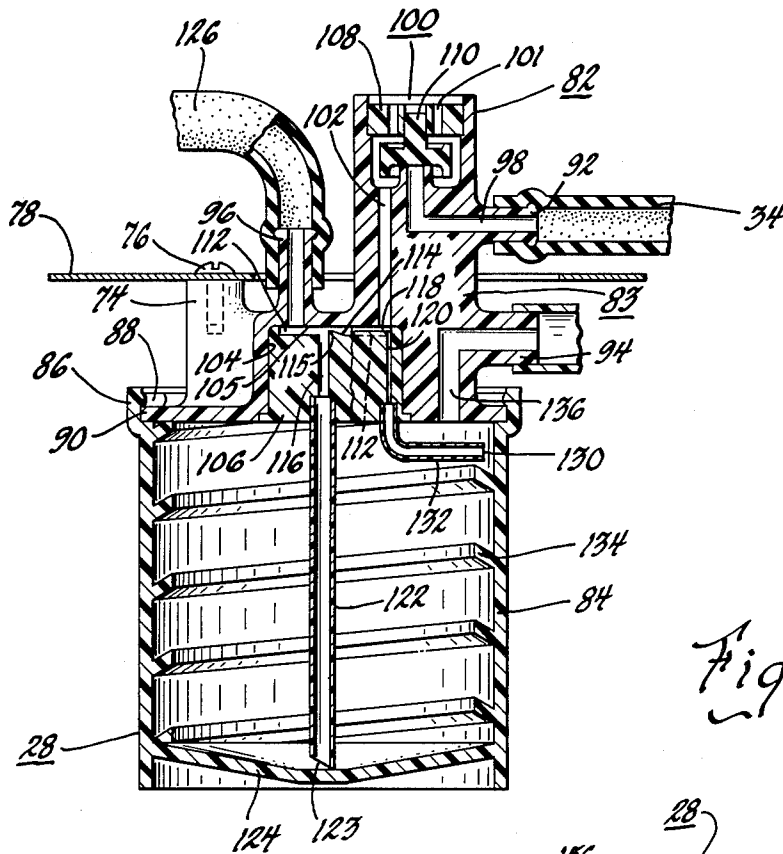

Fig. 3

Fig. 7

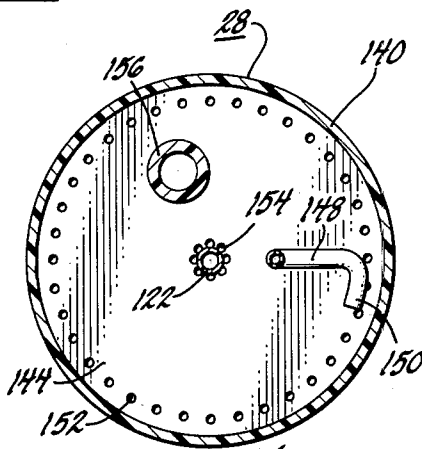
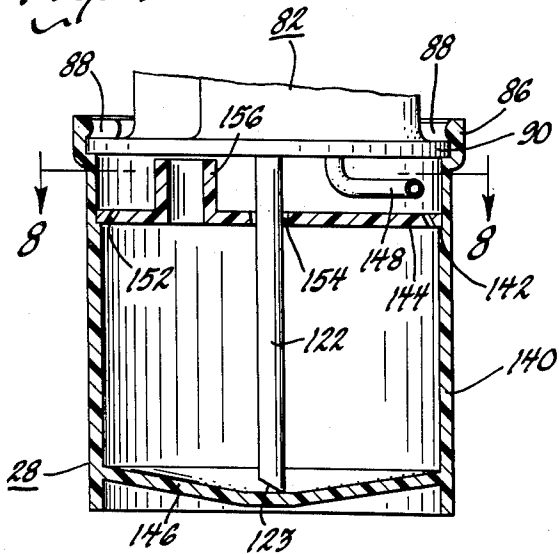

Fig. 8

INVENTOR.

Marvin O. Ross

BY

Frederick M. Ritchie

HIS ATTORNEY

Feb. 6, 1962

M. O. ROSS  
DISPENSING DEVICE

3,019,629

Filed May 4, 1959

4 Sheets-Sheet 4

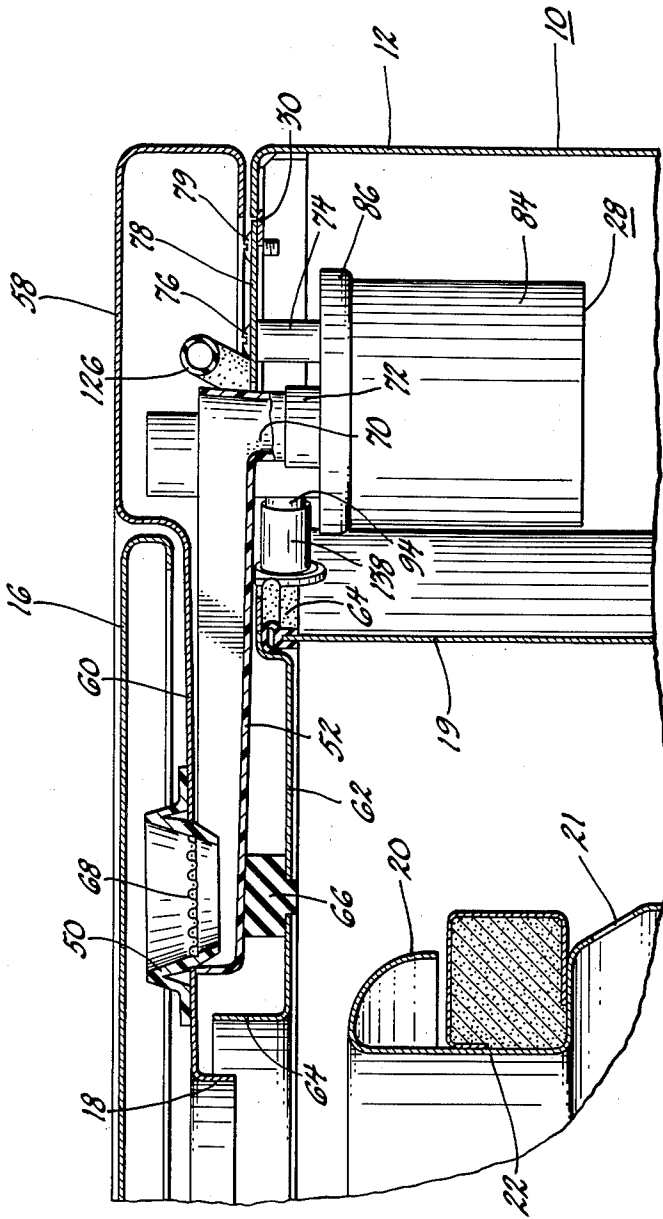

Fig. 6

INVENTOR.  
Marvin O. Ross  
BY  
*Fredrick M. Ritchie*  
HIS ATTORNEY

1

3,019,629

## DISPENSING DEVICE

Marvin O. Ross, Dayton, Ohio, assignor to General Motors Corporation, Detroit, Mich., a corporation of Delaware

Filed May 4, 1959, Ser. No. 310,851  
11 Claims. (Cl. 68-17)

This invention relates to a domestic appliance and more particularly to an improved self-cleaning dispensing device for a washing machine.

The development of the dispensing art as regards the dispensing of wash agents such as detergent and water conditioner has been impeded by the tendency of such materials to corrode and crystallize on the components of the dispenser. Such corrosion or crystallization adversely affects the operation of the dispenser and shortens the life thereof by impairing the consistency of the dispensing operation. In particular the dispensing of bleach has been found troublesome. The evaporation of small amounts of bleach remaining in the bottom of the dispenser causes the bleach concentrate to crystallize and clog the small orifices of the dispenser. Another long standing aim in the washing art has been the development of a dispenser which will selectively dispense either a liquid or a solid washing agent from the same structure.

Accordingly, it is an object of this invention to provide a dispenser having a self-cleaning feature.

It is also an object of this invention to provide a dispenser with a self-cleaning feature which is initiated by the same means utilized to actuate the dispensing operation.

Another object of this invention is an improved dispensing device for a washing machine which utilizes an education principle initiated by the water supply to the washing machine.

A still further object of this invention is to provide a simplified dispenser having an insert portion which is interchangeably designed to accommodate the dispensing of different washing agents.

Another object of this invention is embodied in a dispenser for a washing machine which may be supported in a portion of said washing machine remote from the spin basket and which has means for refilling said dispenser from a position adjacent said spin basket.

A further object of this invention is embodied in an education operated dispenser having a storage container and means for metering a cleaning fluid to the side walls of the container for self-cleaning purposes.

It is also an object of this invention to provide a dispenser which is effective to dispense either a solid or a liquid washing agent.

Further objects and advantages of the present invention will be apparent from the following description, reference being had to the accompanying drawing wherein preferred embodiments of the invention are clearly shown.

In the drawings:

FIGURE 1 is a fragmentary diagonal side sectional view of a washing machine provided with the dispensing arrangement of this invention;

FIGURE 2 is a fragmentary sectional view with parts broken away at the front corner of a washing machine provided with the dispenser of this invention;

FIGURE 3 is a side sectional view taken along line 3-3 of FIGURE 2 of the dispenser and storage bowl or container;

FIGURE 4 is a top elevational view of the dispenser insert portion of this invention;

FIGURE 5 is an exploded sectional view of the dispenser body assembly;

FIGURE 6 is a fragmentary side sectional view taken along line 6-6 of FIGURE 2;

2

FIGURE 7 is a fragmentary side sectional view of a modified form of a dispenser container portion; and

FIGURE 8 is a sectional view taken along line 8-8 of FIGURE 7 to show the water distribution plate for this modified container portion.

In accordance with this invention and with reference to FIGURE 1 a washing machine 10 is provided with an outer cabinet or casing 12 having an upstanding control housing or console 14 and a top access lid 16 overlying an opening 18 in the top panel 58 of said cabinet 12. Enclosed within the cabinet 12 is a water container 19 and a spin basket 20 having an access opening 22 beneath the opening 18 in the cabinet 12. A bulkhead 24 seals the lower end of the generally cylindrical water container 19 and has an outlet 26 leading therefrom for draining the washing machine 10 in accordance with conventional practice. Water is forced into the water container 19 through tub outlet ports 21 when the tub is spun by an agitator and spinning mechanism more fully taught in the patent to Sisson 2,758,685 which issued August 14, 1956. Within one corner of the washing machine 10 is a dispensing apparatus shown generally at 28. The dispensing apparatus 28 may be mounted on a gusset 30 in a corner of the cabinet 12.

The dispenser 28 is adapted to be operated by an education principle wherein actuating water enters a dispenser body assembly 32 through a water supply inlet line 34. So that the dispensing may be selectively energized at any given point in the washing cycle, the water supply line 34 is connected to an auxiliary outlet 36 in a water control valve 38. Entering the valve 38 is a cold water inlet 40 controlled by a solenoid 42, a hot water inlet 44 controlled by a hot water solenoid 46 and the auxiliary outlet 36 controlled by the solenoid 47. With the valve 38 a conventional timer control cycle may call for a hot water fill through the supply line 48 to the tub 20, a cold water fill or a mixed temperature fill simply by selectively energizing the solenoids 42 and 46. In addition to this conventional supply arrangement to the tub 20 the valve 38 is provided with the auxiliary port 36 which may be selectively opened by solenoid 47 at desired points in the washing cycle to admit hot water to the dispenser water supply line 34 for initiating the operation of the dispenser 28. Experience has determined that hot water or fluid makes the best actuating medium for the dispenser of this invention. The heat of the fluid aids in dissolving or commingling the substances to be dispensed. Still it should be recognized that the utilization of cold water for these purposes falls within the purview of this invention.

A liquid washing agent such as bleach may be placed in the dispenser 28 through a fill grommet 50 overlying a chute fill channel or trough 52 extending between the grommet 50 and the dispenser 28.

The mounting arrangement of the dispenser 28 is believed best seen in FIGURE 6 wherein the cabinet 12 is shown with a top portion 58 having a recessed ledge 60 extending beneath the access lid 16. The ledge 60 terminates in the cabinet opening 18 and serves to support the fill grommet 50 through which washing substances may be placed into the dispensing apparatus. FIGURES 2 and 6 are effective to show the water container 19 in its relationship to the spin tub 20 and the dispenser 28. In this relationship a sub-top member or plate 62 is supported upon a seal 64 at the top of the generally cylindrical water container 19. The sub-top 62 extends about the water container 19 and serves to prevent clothes from being spun from the tub 20 into the space between the tub 20 and the water container 19. The sub-top 62 includes an upstanding flange 64 which is utilized to support the discharge hose 126 of the dispenser as will be explained more fully hereinafter. A spacer block 66 is placed in fixed relationship to the sub-top 62 and

3

serves to retain the fill channel 52 in correct relationship to the fill grommet 50. Within the grommet 50 a screen 68 may be positioned to strain undesirable foreign particles from the washing agent being supplied to the dispenser 28. As the fill channel 52 extends beneath the ledge 60 to the corner of the cabinet 12 it is formed with an outlet opening 70 which connects to a washing agent supply inlet boss 72 and thus serves to carry any washing agents from the supply grommet 50 to the inlet 72 of the dispenser remotely positioned beneath the top panel 53 of the washing cabinet 12. In FIGURE 6 the mounting arrangement for the dispenser 28 illustrates a boss 74 on the dispenser 28 as fastened by a bolt 76 to a metal plate 78 which is in turn screwed at 79 to the corner gusset 30. With this arrangement the washing machine may be assembled in its entirety with the dispenser 28 being placed into its relationship with the gusset 30 just prior to installing the top 53 of the cabinet.

In many of the prior art devices the dispensing arrangements depend on electrically actuated devices to pump fluids or washing agents to the washing tub at desired points in the washing cycle. However, this requires pumping structures which are too expensive for a competitive market and which add to the servicing problems of the washing apparatus. In the dispensing arrangement of this invention, the solenoid operated water valve of the aforementioned Sisson patent may be modified to provide an auxiliary port which may be utilized to direct to the dispenser 28 a washing agent carrier stream of wash water or any other cleansing fluid or liquid which is being selectively admitted to the tub 20. Thus, the dispenser 28 is essentially trouble-free and is dependent merely on the operation of a modified solenoid water inlet valve 38.

The operation of the dispensing device of this invention will be most clearly understood with reference to FIGURE 3. In this view, the dispenser 28 is shown comprised of a dispenser body assembly 82 and a receptacle, container or bowl portion 84. The major component of the assembly 82 is the body portion 83. Both the dispenser body 83 and the bowl 84 may be made from a suitable plastic material such as Styrene. For connecting the dispenser body portion 83 and the bowl 84, the bowl 84 is provided with a cylindrical open end flange 86 which has a plurality of spaced tabs or protuberances 88 about the inside wall of flange 86. A radially extending flange or ledge 90 on the dispenser body 83 interlocks with the tabs 88 by snapping thereover and may be cemented in place to form a secure structure.

The dispenser body 83 is formed with a water supply fill inlet 92 at the upstream side of the dispenser and an overflow outlet 94. Also leading from the dispenser body 82 is a discharge outlet 96 at the downstream side which serves to pass the mixture of dispensed washing agent from the container 84 and water which has been supplied through inlet 92. Within the dispenser body an inlet passage 98 leads to a vacuum breaker shown generally at 100. On the downstream side of the vacuum breaker 100 a passage 102 is formed which leads to an eduction or dispenser actuating chamber 104 in the dispenser body 83. Thus the flow of water which initiates the dispensing operation follows a course from the inlet 92 by means of the passageway 98 to the vacuum breaker 100, and by means of passageway 102 to the eduction chamber 104 from which point it is discharged through outlet 96 along with the washing agent entrained therewith. In the device as explained so far the dispenser body 82 is merely provided with passageways there-through. No means has yet been set forth for setting up a restriction, whereby an eduction or suction is created to operate the dispenser. For this purpose and in accordance with a major aspect of this invention the chamber 104 may be fitted with a dispenser insert 106 formed in accordance with the characteristics of any washing agent to be dispensed.

4

The components of the dispenser body assembly 82 are more clearly seen in the exploded view of FIGURE 5 wherein the assembly is comprised of a dispenser cap 108, a check valve plug 110 of synthetic rubber or the like, the dispenser body portion 83 and the dispenser insert 106. These components may be molded in accordance with practices well known in the molding art and are simply and expeditiously assembled. Cementing may be used to join these parts which do not move relatively.

The dispenser insert portion 106 is formed with an eduction or throttling channel 112 and a transverse protuberance or weir 114 approximately at the longitudinal middle of the channel. Immediately downstream of the protuberance 114 is a suction passageway 116. Leading from the downstream end of channel 112 (FIGURE 4) is a cleansing bleed channel or dissolution bypass 118 which terminates in a downwardly extending port 120 in the insert 106. Where the dispensing apparatus 28 is to be utilized for a liquid bleach or the like the insert 106 may be designed as follows. The protuberance 114 may form an angle A (FIGURE 5) of 15°. For satisfactory withdrawal of a liquid bleach into a channel 112 which is .080 inch wide by .051 inch deep, the suction port 116 should be approximately .080 inch in diameter and the bleed orifice 120 .032 inch in diameter. Proper dispensing requires close control over the formation of the protuberance 114. Thus, a flat 115 is formed which permits a constant dimension to exist between the flat 115 and top wall 105 of the eduction chamber 104. More particularly, the dimension between flat 115 and wall 105, as it pertains to the design just set forth for the liquid bleach function, is .031 inch. It should be obvious that the dispenser insert 106 may be redesigned in accordance with any washing agent to be dispensed simply by varying these dimensions or the configurations of the protuberance 114. For instance, the bleed rate through the bypass channel 118 and bleed orifice 120 must be greater during the dispensing of granular solids. Whereas approximately a 3 ounces per minute bleed provides the self-cleaning feature of this invention during liquid dispensing, it has been found that about a 7 or 8 ounce per minute bleed is necessary for dispensing solids. This amount is effective to dissolve the solid and to clean the chamber as the solid is dispensed. Thus, in a solid agent dispensing apparatus utilizing the teachings of this invention the bleed line should be made larger—large enough to dissolve the solid and cleanse the container 84 during the time interval that the solenoid 47 is energized. It should be equally obvious that the insert 106 may be readily moldable in an inexpensive process and may be mass produced in a design which will accommodate any desired dispensing function.

Again with reference to FIGURE 3 wherein the dispensing apparatus 28 is shown in assembled fashion the insert 106 is shown cemented securely within the chamber 104 of the body portion 83. As water or other cleansing liquid being dispensed through the valve 38 traverses the passageways 98, 102 to the discharge outlet 96 the restriction or protuberance 114 will create a turbulence in the channel 112 to set up a suction in the suction port 116. Connected to the suction port 116 is a suction tube 122 having a bias cut terminal portion 123 which opens onto a generally conically formed bottom 124 in the storage bowl 84. The suction created by the passage of water from the inlet 92 to the outlet 96 will effect a withdrawal of the washing agent within the bowl 84 to entrain and mix the agent with the supply water itself. As the water supply continues to flow into inlet 92 from supply 34 the mixture of supply water and washing agent will discharge through the outlet 96 and be carried by means of a discharge tube 126 (FIGURE 2) to an outlet hose grommet 128 held securely in the upstanding flange 64 of the sub-top 62. This mixture of water and washing agent will be projected into the tub

5

20 through the opening 22 thereof to perform its function at any selected point in the washing cycle that the solenoid 47 is energized to open the auxiliary port 36. With this dispensing arrangement means are generally necessary which will prevent contamination of the domestic water supply. A vacuum breaker such as 100 will serve this purpose. As water is supplied to the dispenser inlet 92, the check valve plug will lift to close the vent openings 101 and open the supply passage 98 to the passage 102. On the other hand, if a vacuum is pulled on the dispenser at its inlet 92, the plug 110 will seat. Any leakage around the plug will not contaminate the water supply for such leakage would consist solely of air drawn into the system through vent openings 101.

Another major aspect of this invention is directed to the means whereby the bowl 84 is made self-cleaning to prevent the crystallization of washing agents about the opening of the suction tube 122 and on the walls of the bowl or container 84. For this purpose a bowl cleaner tube 130 is connected to the bleed line port or orifice 120 and is further formed with a laterally extending portion 132 which directs water bled through the orifice 120 to a position adjacent the side walls of the bowl 84. As a further aid in cleaning the side walls of the bowl 84 a spiral thread 134 is formed within the cup 84 and serves to direct the water sprayed from the bowl cleaner tube 130 in a spiral path about the cylindrical wall of the bowl 84 to a position at the bottom 124 of the bowl. To better guide the cleaning water a slight upward slant is given to the thread 134. The cleansing path thus formed serves to carry the water from bleed tube 130 along the wall of the bowl 84. The walls will be cleaned of any excess washing agent and the bowl 84 will be maintained in a clean condition free from the accumulation of crystals about the suction tube 122.

As set forth hereinbefore, the dispenser is equally effective to dispense solids as well as liquids. Where the dispensing apparatus 28 is utilized to dispense a solid or granular washing agent, the spiral thread arrangement 134 serves to carry the approximately 8 ounces per minute bleed line supply of water about the periphery of the bowl 84, thereby dissolving gradually the granular substance along the outer surfaces thereof. As the granular substance dissolves, the liquid concentrate gravitates and accumulates along the conical bottom 124 of the bowl 84 and is withdrawn up the suction tube 122 to the channel 112 and the discharge line 126. For liquid dispensing flow rates of approximately 14 ounces per minute withdrawn from the bowl 84 through the suction tube 122 and approximately 3 ounces per minute bled into the bowl 84 through the bowl cleaner tube 130 have been found particularly effective in providing the self-cleaning feature of this invention as well as the dispensing of liquids. Should the liquid dispensed be bleach it is necessary that a minimum dilution of five parts water to one part liquid bleach be maintained to prevent "bleach burn" on the fabrics. This dilution and the last mentioned flow rates (14 ounces and 3 ounces per minute) may be achieved in a dispenser using the aforementioned dimensions for the restrictive protuberance 114.

The dispensing apparatus 28 is provided with an overflow outlet 94 to which a passageway 136 leads from the bowl 84. Thus if water or fluid washing agent is admitted to the container or bowl 84 faster than it is removed, the excess will overflow through the passageway 136 and be carried off by means of an overflow nozzle 138 which is secured in the wall of the water container 19. After the overflow is carried into the water container it will be discharged from the washing machine to drain through the outlet 26 without adulterating the contents of the tub 20. Note the lip 139 which partially overlies the opening of nozzle 138. This prevents water from being thrown into the overflow nozzle when the spin tub 20 is in a spinning operation.

Another embodiment of this invention is best seen in

6

FIGURES 7 and 8 and provides another arrangement whereby laundry substances may be dispensed by a wash water initiated eduction process and whereby the storage container for the laundry substance is left in a clean condition at the termination of each dispensing operation. In the embodiment of FIGURE 7, a storage bowl or receptacle 140 is provided with a shoulder 142 for supporting a circular water distribution plate 144. As with the earlier embodiment a suction tube 122 extends downwardly to a conical bottom wall or sump portion 146 in the bowl 140. Thus as the dispensing assembly 82 is actuated by the admission of water supply thereto, the liquefied wash agent is withdrawn from the cup 140, entrained with the water initiating the withdrawal and transmitted in mixed fashion to the wash tub 20. In this dispensing arrangement, the bowl cleaner tube 148 is formed with a terminal portion 150 which is tangentially arranged in relation to the side wall of the bowl 140. As a quantity of water is bled from the downstream side of the channel 112 the water will be forced from the terminal end 150 of the tub 148 and will set up a swirling action about the inside of the bowl 140. For distributing or metering the swirling water to the bowl below, the distributing plate 144 is formed with a plurality of ports 152 about the outer edge thereof. The ports 152 are sloped in a direction toward the side wall of the bowl 140 as best seen in FIGURE 7. Similarly a plurality of ports 154 are arranged about the center of the plate 144 and are sloped in a direction facing the outer cylindrical wall of the suction tube 122. Thus, as water is emitted from the tube portion 150, a swirl will be set up and the water will be metered through the outlets or ports 154 and 152 to clean the surfaces of the suction tube 122 and the bowl 140 respectively during the dispensing operation. Further, if the modified dispensing apparatus of FIGURES 7 and 8 is being utilized to dispense a granular washing agent, the metering of fluid or wash water through the ports 152 and 154 will serve to gradually liquefy the granular substance to a form whereby it may be withdrawn by the suction of tube 122. To further accommodate the dispensing of a granular or solid material, the plate 144 is formed with a supply collar 156 which communicates with the inlet opening 72 in the dispenser body 83. As set forth hereinbefore, if a granular substance is to be dispensed, the top panel 58 of the washing machine will be provided with an access panel aligned with opening 72 and through which the granular material may be poured into the dispenser. Also in alignment with opening 72 is the collar 156 in the plate 144 which serves to direct the material being supplied to the storage bowl 140.

It should now be seen that an improved dispensing apparatus has been provided which is self-cleaning and which will dispense both granular and liquid washing agents. Further the dispenser is designed to provide the optimum in flexibility and interchangeability. For this purpose, an insert of variable design may be utilized in a common dispenser body to accommodate the characteristics of any washing agent to be dispensed. It should also be recognized that a plurality of solenoid controlled dispensers such as 28 may be grouped to dispense various washing agents at different points in a timed washing cycle. The teachings of this invention are particularly valuable to such multiple dispensing operations. Complete flexibility is obtained by providing the separate dispensers with different inserts 106 properly designed for each substance to be dispensed. All other components of the dispensers remain identical. Still further it should be obvious that the water valve for initiating a dispensing operation of this type may be incorporated into the housing 83 rather than into the main wash water supply valve such as 38.

While the embodiments of the invention as herein disclosed constitute preferred forms, it is to be understood that other forms might be adopted.

What is claimed is as follows:

1. In combination, a washing machine comprising a cabinet having an access opening, a water container, a washing basket in said water container, a recessed ledge on said cabinet circumscribing said access opening, a lid covering said ledge and said access opening, a fill grommet in said ledge, a flow channel extending from said grommet to a corner of said cabinet, a washing agent dispenser in said corner of said cabinet, said dispenser having a fill opening connected to said flow channel, a storage portion and a dispensing portion, said dispensing portion having a water inlet, a water and washing agent outlet into said basket and an overflow into said water container, means for selectively directing water to said water inlet, interchangeable flow restrictive means between said inlet and said outlet for creating a suction, a suction tube connected to said suction creating means and leading to the bottom of said storage portion, a water bleed line connected downstream from said suction creating means, a descending spiral portion on said storage portion having one end adjacent said bleed line, whereby when said selectively directing means is actuated said washing agent will be drawn from said storage portion and carried to said washing basket and said bleed line water will clean said storage portion.

2. A dispenser comprising, means forming a fluid flow passage having an inlet end and an outlet end, obstructing means in said passage between said ends for restricting said fluid flow to create a suction adjacent said obstructing means, a receptacle member having a top opening defined by a wall, a suction tube extending into said receptacle member from the area of said suction, means downstream from said area of said suction for bleeding a portion of said fluid to said receptacle member, a plate in said receptacle member closing said top opening and having a first plurality of peripherally arranged apertures adjacent said wall for directing said fluid portion to the wall of said receptacle member for cleaning thereof and a second plurality of circumferentially arranged apertures adjacent said suction tube for directing said fluid portion to the exterior surface of said suction tube for cleaning thereof.

3. A dispenser comprising, means forming a fluid flow channel having an inlet end and an outlet end, means in said channel between said ends for restricting said fluid flow to create a suction adjacent said restricting means, a receptacle member having a wall, a suction duct connecting said receptacle member and said channel in the area of said suction, means in said channel for bleeding at least a portion of said fluid to said receptacle, a plate in said receptacle member for receiving said fluid portion and having an outer edge adjacent said wall and an inner edge adjacent said duct, a first aperture in said outer edge for directing said fluid portion to the wall of said receptacle member for cleaning said wall and a second aperture in said inner edge for directing said fluid portion to said suction duct for cleaning said duct.

4. A solid washing agent dispenser comprising, means forming a fluid flow channel having an inlet end and an outlet end, means in said channel between said ends for restricting said fluid flow to create a suction adjacent said restricting means, a container, a suction tube connecting said container and said channel adjacent said restricting means, means in said channel for bypassing a portion of said fluid to said container, means in said container associated with said bypass means for directing said fluid portion into said container for dissolving said solid washing agent and for cleaning said receptacle.

5. A dispensing device comprising, a dispenser body portion and a receptacle portion, said body portion having a fluid inlet, a mixture outlet, an overflow and passage means connecting said inlet and said mixture outlet and including a chamber, vacuum breaker means in said passage means, a dispenser insert for said chamber, said dispenser insert having an eduction channel connected to

said passage means, a bleed channel connected to said eduction channel, a protuberance in said eduction channel, and a suction duct adjacent said protuberance, a suction tube connected to said duct and extending into said receptacle portion, and a cleaning tube connected to said bleed channel and having a terminal portion extending toward a wall of said receptacle, whereby said receptacle wall may be cleaned when said fluid is moving through said passage means.

6. A dispensing device for liquid or solid washing agents comprising, an eduction portion having a closed carrier fluid flow channel and carrier fluid flow restrictive means interchangeably positioned in said channel for selectively restricting said flow to create a suction in accordance with the washing agent to be dispensed for dispensing said washing agent, a container portion below said eduction portion for receiving said washing agents, a suction tube extending from said channel in the area of said suction substantially to the bottom of said container portion to dispense said washing agents, said carrier fluid flow restrictive means including means for releasing above said washing agents a portion of said carrier fluid to said container portion, said last named means having means for distributing said carrier fluid portion along a wall of said container.

7. A dispensing device comprising, a dispenser portion having a closed carrier fluid flow channel and carrier fluid flow restrictive means interchangeably positioned in said channel for selectively restricting said flow to create a suction for dispensing a washing agent, and a receptacle portion connected to said channel in the area of said suction, said carrier fluid flow restrictive means including means for releasing a portion of said carrier fluid to said receptacle portion as a cleansing means therefor.

8. A dispensing device comprising, a dispenser portion having a closed carrier fluid flow channel and unitary means having a protuberance in said channel for restricting said flow to create a suction for dispensing a washing agent, and a receptacle portion connected to said channel in the area of said suction, said unitary means including orifice means for releasing a portion of said carrier fluid to said receptacle portion as a cleansing means therefor.

9. A liquid or solid washing agent dispensing device comprising, an eduction portion having a closed carrier fluid flow channel and carrier fluid flow restrictor means interchangeably positioned in said channel for selectively restricting said flow to create a suction in accordance with the washing agent to be dispensed for dispensing said washing agent, and a receptacle portion below said eduction portion for receiving said washing agent, a suction tube extending from said channel in the area of said suction substantially to the bottom of said container portion to dispense said washing agent, and means connected to said channel for releasing a portion of said carrier fluid to said receptacle portion as a cleansing means for said receptacle portion and a solvent for said solid washing agent, said releasing means having means for distributing said fluid portion over selected surfaces of said receptacle portion.

10. An eduction type dispensing device for different substances comprising a dispenser body portion and a substance container portion, said body portion having a fluid inlet, a mixture outlet, and passage means including a chamber connecting said inlet and outlet, and an interchangeable dispenser fluid flow restrictive insert in said chamber, said insert having a protuberance spaced from a wall of said chamber to form a restriction in said passage means between said inlet and outlet, a first conduit adjacently downstream from said protuberance and connected to said container portion for drawing said substance from said container portion, and a second conduit downstream from said first conduit and connected to said container portion for bleeding fluid to said container

portion for cleaning said container portion, both said protuberance and said second conduit being preformed in accordance with the substance to be dispensed.

11. In combination, a washing machine comprising a cabinet, a washing basket in said cabinet, a fill grommet in said cabinet, a flow channel extending from said grommet, a washing agent dispenser in said cabinet, said dispenser having a fill opening connected to said flow channel, a storage portion and a dispensing portion, said dispensing portion having a water inlet, a water and washing agent outlet and an overflow, means for selectively directing water to said water inlet, means between said inlet and said outlet for creating a suction, a suction tube connected to said suction creating means and leading to the bottom of said storage portion, a water bleed line connected downstream from said suction creating portion, a water distributing means connected to said storage portion adjacent said bleed line, whereby when said

selectively directing means is actuated said washing agent will be drawn from said storage portion and carried to said washing basket and said bleed line water will clean said storage portion.

References Cited in the file of this patent

UNITED STATES PATENTS

769,818	Cunneen -----	Sept. 13, 1904
1,155,946	Miller -----	Oct. 5, 1915
1,469,625	Dodge -----	Oct. 2, 1923
1,865,289	Trowbridge -----	June 28, 1932
2,228,914	Pierce -----	Jan. 14, 1941
2,501,047	Gustafsson -----	Mar. 21, 1950
2,523,799	Woodson -----	Sept. 26, 1950
2,523,801	Woodson -----	Sept. 26, 1950
2,619,825	Rosenkrans -----	Dec. 2, 1952
2,785,833	Bauerlein -----	Mar. 19, 1957