



(22) Date de dépôt/Filing Date: 2001/11/26

(41) Mise à la disp. pub./Open to Public Insp.: 2003/05/26

(51) Cl.Int.⁷/Int.Cl.⁷ B65D 81/34

(71) Demandeurs/Applicants:
SARIC, JERKO, CA;
SESTAK, IVAN, CA

(72) Inventeurs/Inventors:
SARIC, JERKO, CA;
SESTAK, IVAN, CA

(74) Agent: BLAKE, CASSELS & GRAYDON LLP

(54) Titre : MECANISME DE DECLENCHEMENT DE REACTION AMELIORE POUR EMBALLAGES OU CONTENANTS
AUTO-CHAUFFANTS OU AUTO-REFROIDISSEURS RIGIDES ET NON RIGIDES

(54) Title: IMPROVED TRIGGER MECHANISM FOR SELF-HEATING/COOLING PACKAGES OR CONTAINERS
UNIVERSALLY APPLIED TO BOTH RIGID AND NON-RIGID PACKAGES AND CONTAINERS

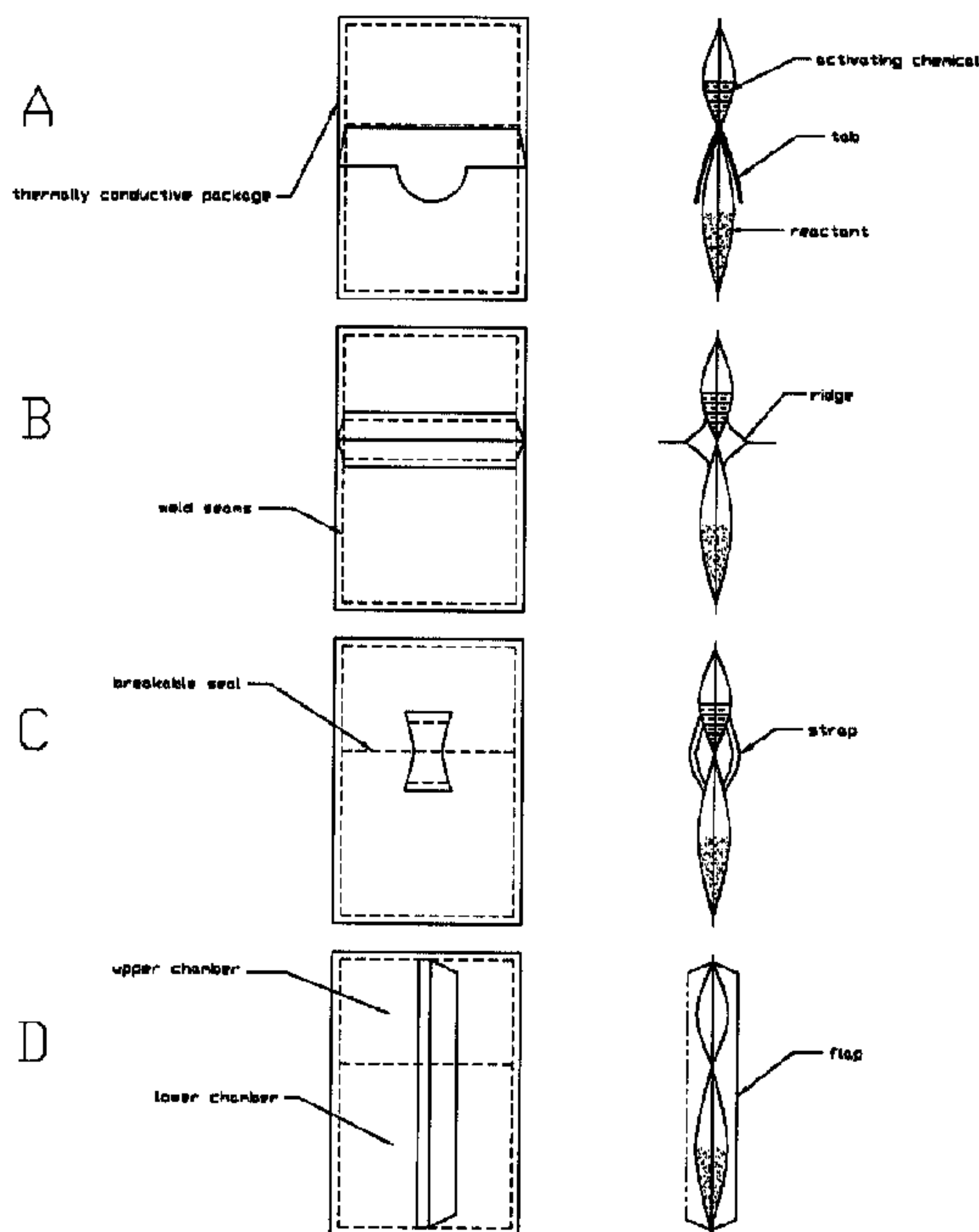

(57) Abrégé/Abstract:

A trigger mechanism applied to rigid and non-rigid packages and containers to either heat or cool said containers. Said trigger mechanism including a non-porous flexible chamber containing an activating solution connected to another non-porous or porous, flexible chamber containing a reagent wherein previous said chamber is separated from latter said chamber by a breakable seal thus forming the heater/cooler. Said trigger mechanism including at least one appendage, tab, string, tape, strap or ridge, attached (or otherwise integrally formed as part of the packaging) to the outer package of the heater/cooler so that when stress is applied (i.e. pulling action such as opening of a potato chip bag), there is a uniform break along the breakable seal dividing the solution chamber from the reagent chamber causing the chemicals to mix thus initiating the exothermic/endothemic reaction.

ABSTRACT

A trigger mechanism applied to rigid and non-rigid packages and containers to either heat or cool said containers. Said trigger mechanism including a non-porous flexible chamber containing an activating solution connected to another non-porous or porous, flexible chamber containing a reagent wherein previous said chamber is separated from latter said chamber by a breakable seal thus forming the heater/cooler. Said trigger mechanism including at least one appendage, tab, string, tape, strap or ridge, attached (or otherwise integrally formed as part of the packaging) to the outer package of the heater/cooler so that when stress is applied (i.e. pulling action such as opening of a potato chip bag), there is a uniform break along the breakable seal dividing the solution chamber from the reagent chamber causing the chemicals to mix thus initiating the exothermic/endothemic reaction.

DESCRIPTION OF THE INVENTION

Said heating/cooling mechanism may include one or more flexible, rigid, porous/non-porous product container(s). Wherein the surface or part of the surface of the heater/cooler may form at least a portion of the product container/package.

In one specific embodiment, a rigid box-like container (containing the substance to be heated/cooled) may be wrapped in an outer, preferably thermally insulated sheet-like material. On at least one of the sides of the box-like container, weld-seams are formed along the perimeter of the plane. This creates an envelope space between the inner box-like container and the outer package on at least that one-side of the container. A weaker, breakable seal is formed across the side of the box-like container dividing the envelope space into two. One chamber may contain the solvent/activating solution and the other contains the corresponding reagent. At least one appendage, tab, string, tape, strap or ridge, attached to or forming part of the outer packaging (referred to as trigger mechanism) is incorporated so that when pulled by hand (while the other hand holds the container) the stress breaks the weaker seal pulling the outer package away from the inner, box-like container causing the chemicals to mix initiating the reaction.

Another specific embodiment of said invention contains all of the elements described above with the exception that instead of an inner box-like product container, there is a flexible pouch-like product container/package. There are at least 2 trigger mechanisms. One located on the same side as the heating/cooling elements, the other trigger mechanism on the opposing side of the container, such that when both or pulled, the entire package flexes to its maximum at which point, the stress breaks the seal dividing the heating/cooling elements thus triggering the reaction.

As previously stated, the triggering mechanism may be in the form of an appendage, tab, string, tape, strap or ridge, or any similar form as long as it is attached to or integrated as part of the outside of the exterior packaging and enable the user to grasp on so as to provide pulling resistance. Said trigger mechanism may be rigid or flexible. Said trigger mechanism may be incorporated into any portion(s) of the exterior packaging, but preferably close to or traversing breakable seal in order to apply maximum stress to the breakable seal vicinity.

One embodiment includes a package having one or more products/product containers/product pouches with one or more heating/cooling elements wherein said product containers/packages may be rigid or flexible. Each heating/cooling element may have its own triggering mechanism or trigger mechanisms. Heating/Cooling chambers may be formed at least in part from a flexible or rigid packaging material. Said chambers may be independent or at least in part be formed from the product packaging/container which in turn may be at least in part from either or both flexible or rigid material.

This type of packaging and triggering mechanism will prove highly useful when one is transporting volatile, hazardous, unstable, reactive or explosive compounds of chemicals, or chemicals with a pre-determined life or length of use. Said chemicals or

compounds can be separated into the two chambers in non-reactive, non-volatile, non-hazardous, non-explosive states. When the chemical is needed, the chemicals can be mixed by triggering the triggering mechanism and causing the chemicals to mix, react and produce the final product chemical needed for the particular application.

For rigid packages an adhesive tape can be wound around flexible outer package thereby pinching part of outer package against inner rigid packaging creating two envelope spaces between outer flexible package and inner rigid package to form another type of trigger mechanism. One envelope above, the other below the adhesive tape such that when tape is unwound, the two envelopes join allowing chemicals to mix, thereby initiating the reaction.

DESCRIPTION OF DIAGRAMS

Fig. 1 schematic and cross-section of the basic heating/cooling element with trigger mechanisms.

Fig. 2 schematic and cross-sectional view of heating/cooling element with trigger mechanism all of which is incorporated as part of packages, containers or pouches containing products to be heated/cooled.

Fig. 3 schematic and cross-sectional view of a self-heating/cooling package/pouch where product to be heated/cooled is positioned between heating elements.

Fig. 4 schematic and cross-sectional view of a self-heating/cooling package/pouch with the heating/cooling element in the middle.

Fig. 5 embodiment depicting multiple chambers.

Fig. 6 another embodiment depicting multiple chambers.

Fig. 7 embodiment with shortened breakable seal.

Fig. 1 depicts the preferred embodiments of said invention. In the basic design, two chambers are separated by a breakable seal with at least one trigger mechanism forming the heating/cooling element. Ideally, said invention should be flexible (at least partially) non-porous and thermally conductive. It may be opaque or transparent, made of a laminated or a non-laminated material. It may also be made of a composite material or multiple layer material. Said invention may be formed by folding said sheet layer, with the folded edge becoming the bottom of the heating/cooling element package. The sides are held together preferably with weld seams to form the complete element or unit. The chemical may be placed in the formed pouch/package. A breakable seal is then formed across the general middle area of the package completely enclosing said chemical. Another is added adjacent to the seal and the total package is sealed at the top. The trigger mechanism(s) is added at any point during the manufacturing of said package. Fig. 1A through 1D depict different trigger mechanisms used. Any individual skilled in the art can adapt said trigger mechanisms in an infinite multitude of ways without deviating from the general idea of said invention. In the diagrams depicted at least one trigger mechanism is applied. The heating/cooling element can be held down by one hand (or any other means) while the other hand triggers said mechanism. Ideally however, the pulling devices are used to trigger said invention by pulling in opposite directions for each heating/cooling element.

Fig. 2 shows diagrams embodying all of the elements described above with the exception that a product or product package is enclosed within an outer package (preferably thermally insulated) that also contains the heating/cooling element.

The inner product package may be rigid, flexible, or partially rigid. The outer package may be partially or fully flexible. In the embodiments depicted in Fig. 2, the

outer package is thermally insulated, flexible, and partially forms the chemical chambers. The inner product package completes the chambers. Several embodiments can be considered by anyone skilled in the art. In another similar embodiment to Fig. 2, the heating/cooling element may be a separate unit added or inserted into a product package. In this specific embodiment, the heating/cooling element should be attached to the inside of the outer package (e.g. weld seams), at least partially, such that pulling a trigger mechanism on the outside of the outer package will break the frangible seal of the heating/cooling element inside.

Fig. 3 depicts embodiments of a self-heating/cooling package/container with the product positioned between the heating/cooling elements. Fig. 4 depicts embodiments where the heating/cooling elements are positioned in the middle. An infinite number of variations are possible to anyone skilled in the art without departing from the main idea of the invention.

Fig. 5 -

- A - two chambers separated by a breakable seal with its own triggering device i.e. pull-tab forming a heating/cooling element.
- B - plurality of elements in A such that each element is independent of the other.
- C - used for example in a heating device to control the intensity of duration of temperature change (i.e. more elements triggered, more heat released).

Fig. 6 two or more adjacent chambers where each chamber is separated by the next chamber and by a breakable seal wherein each seal is broken by its own trigger mechanism (i.e. pull-tab) such that if there are N chambers, there are $N-1$ breakable seals and trigger mechanisms separating each adjacent chamber.

Fig. 7 possible variation with smaller breakable seal – may improve flow of liquid/powder from one chamber to the other when the seal is broken.

APPLICATIONS

- Heat or cool liquids, foodstuff, creams, lotions, personal care products, wet/dry wipes(s), medical products.
- Heating/cooling body parts (emergency) and medical (i.e. hot/cold compress)
- Mixing potentially volatile, hazardous or unstable chemicals

Advantages of said invention include easier, uniform, complete breakage of frangible seal as opposed to rupturable/squeezable counterpart. Reduced chance of accidental triggering. Said invention applies to rigid/flexible, works well in any size package (as opposed to counterpart) and cost effective.

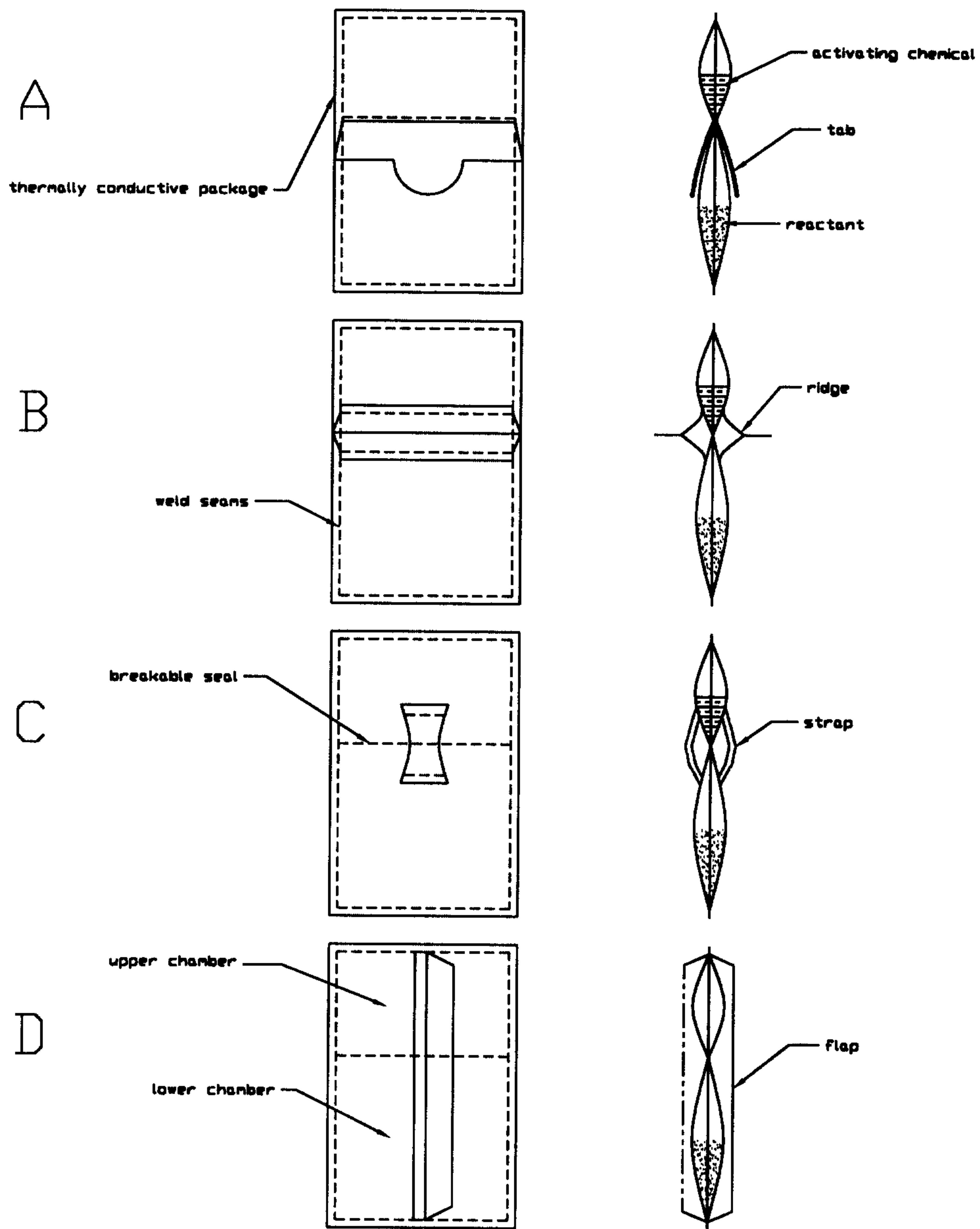

FIGURE 1

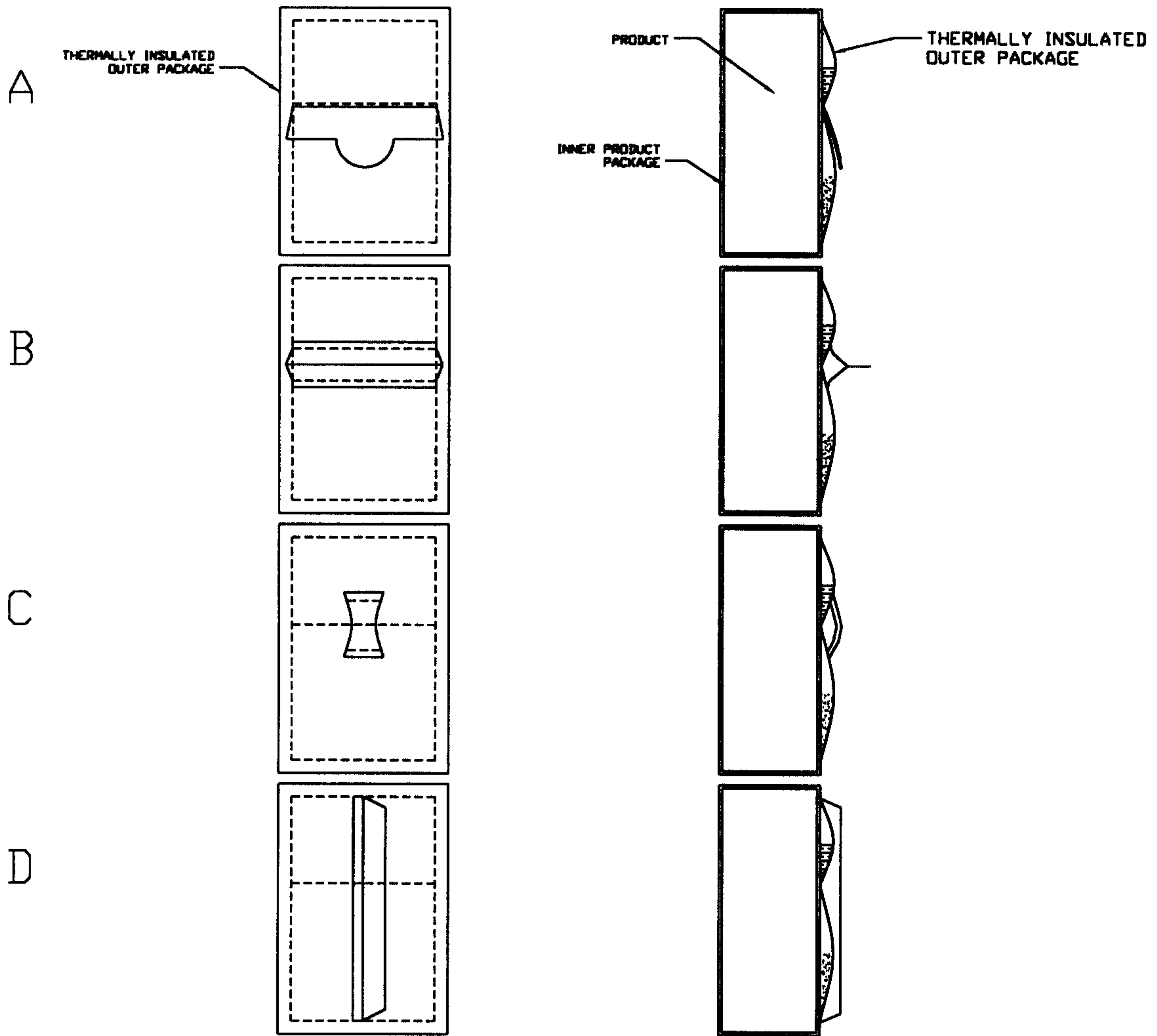

FIGURE 2

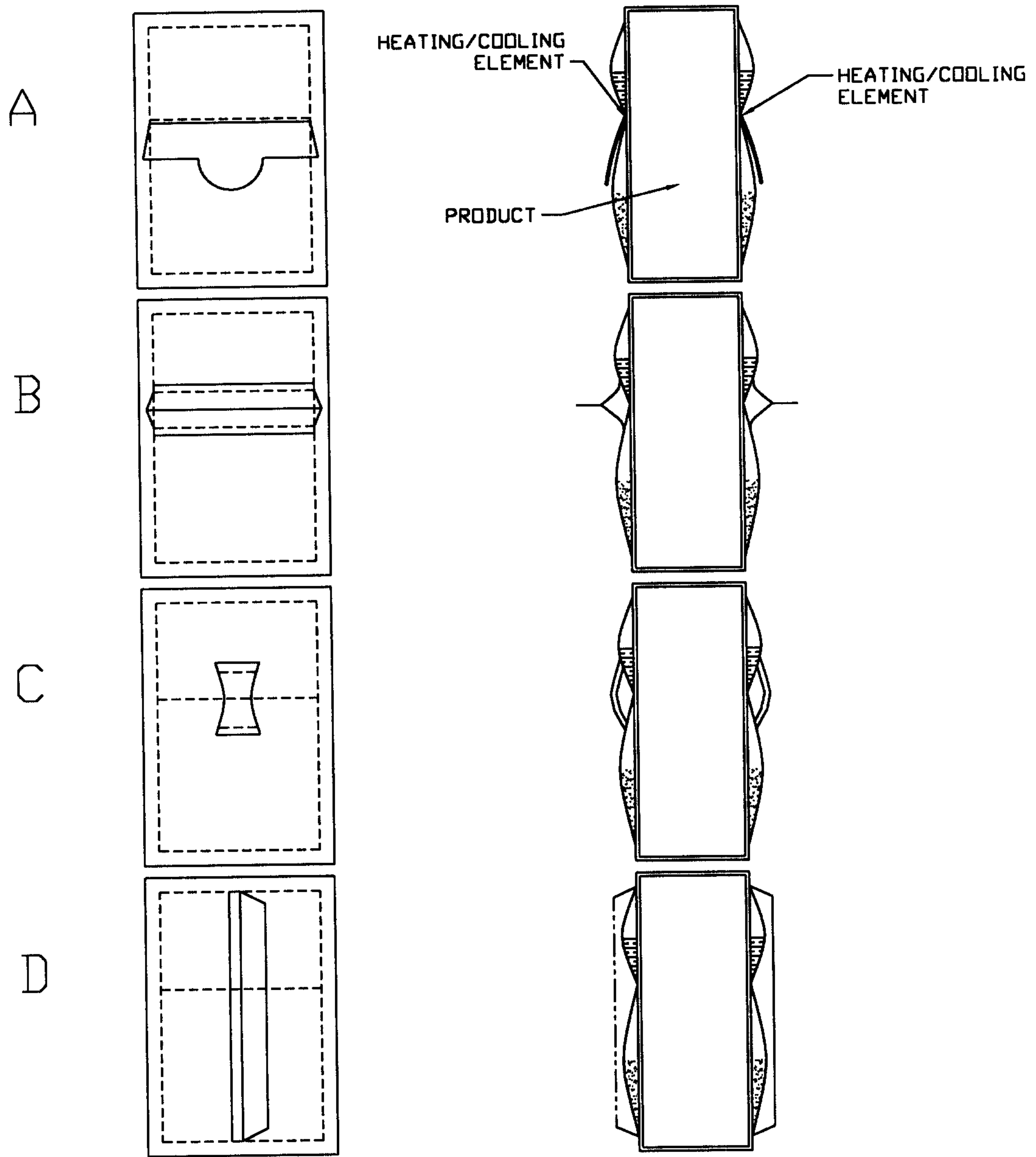

FIGURE 3

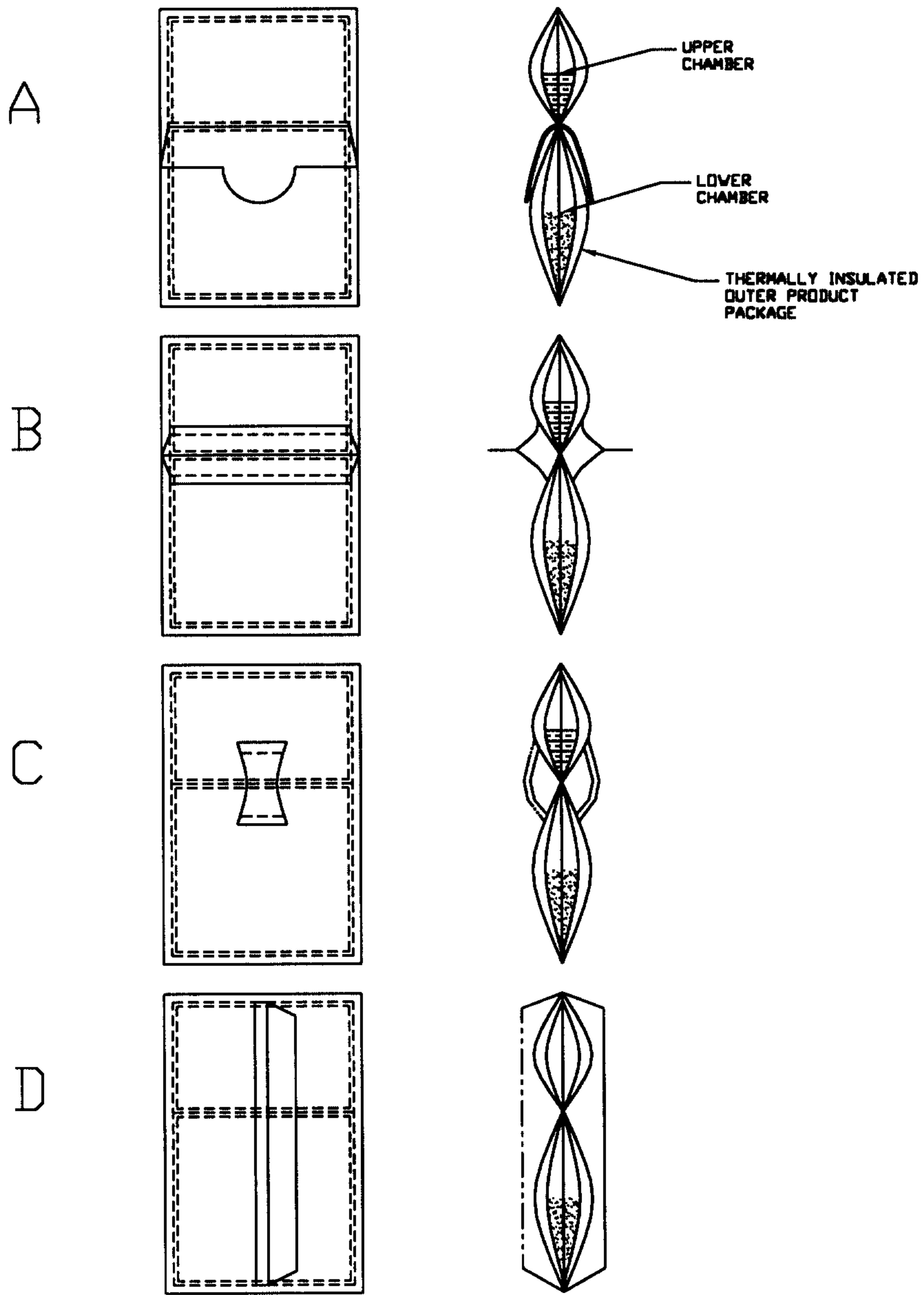

FIGURE 4

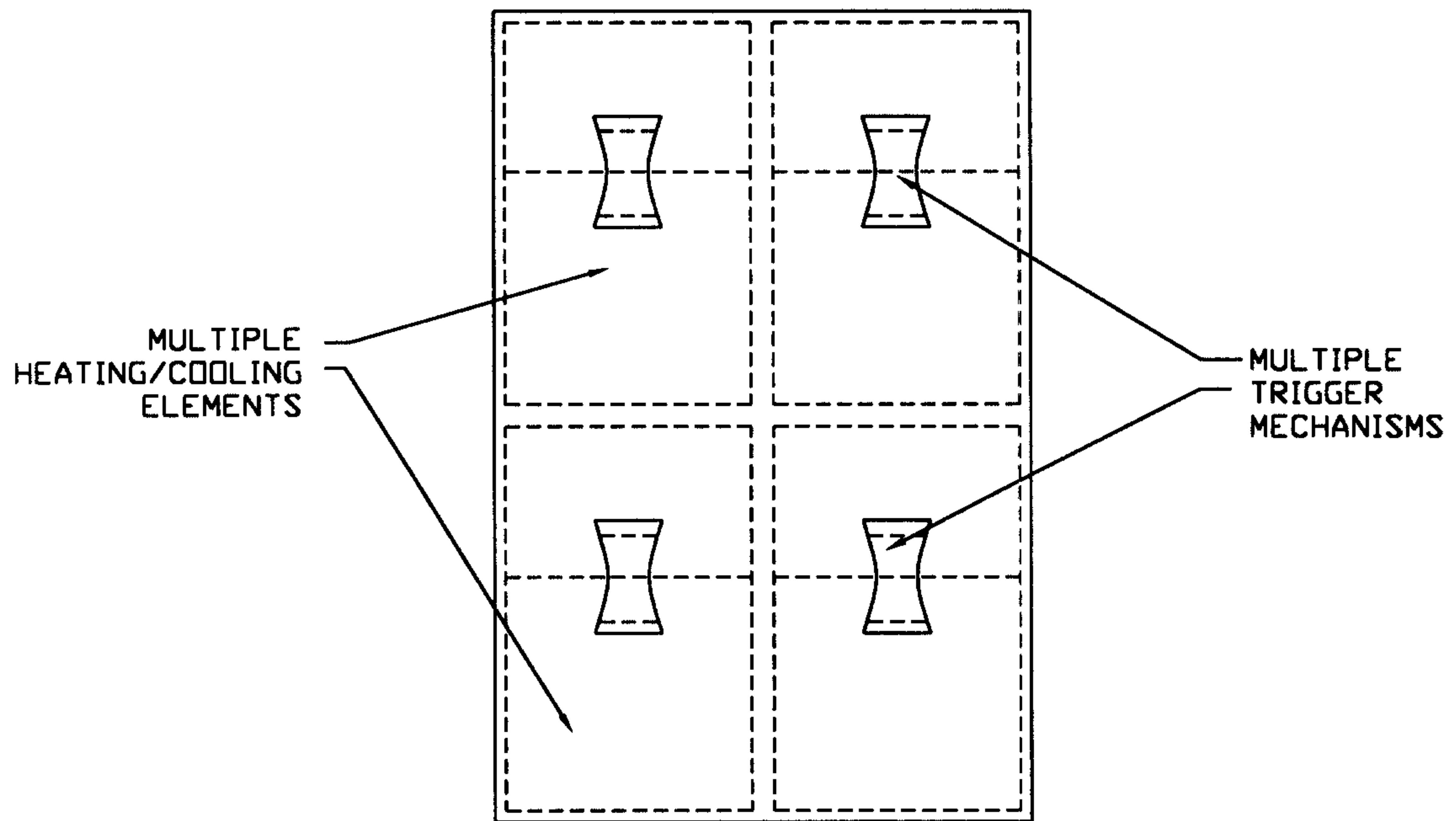

FIGURE 5

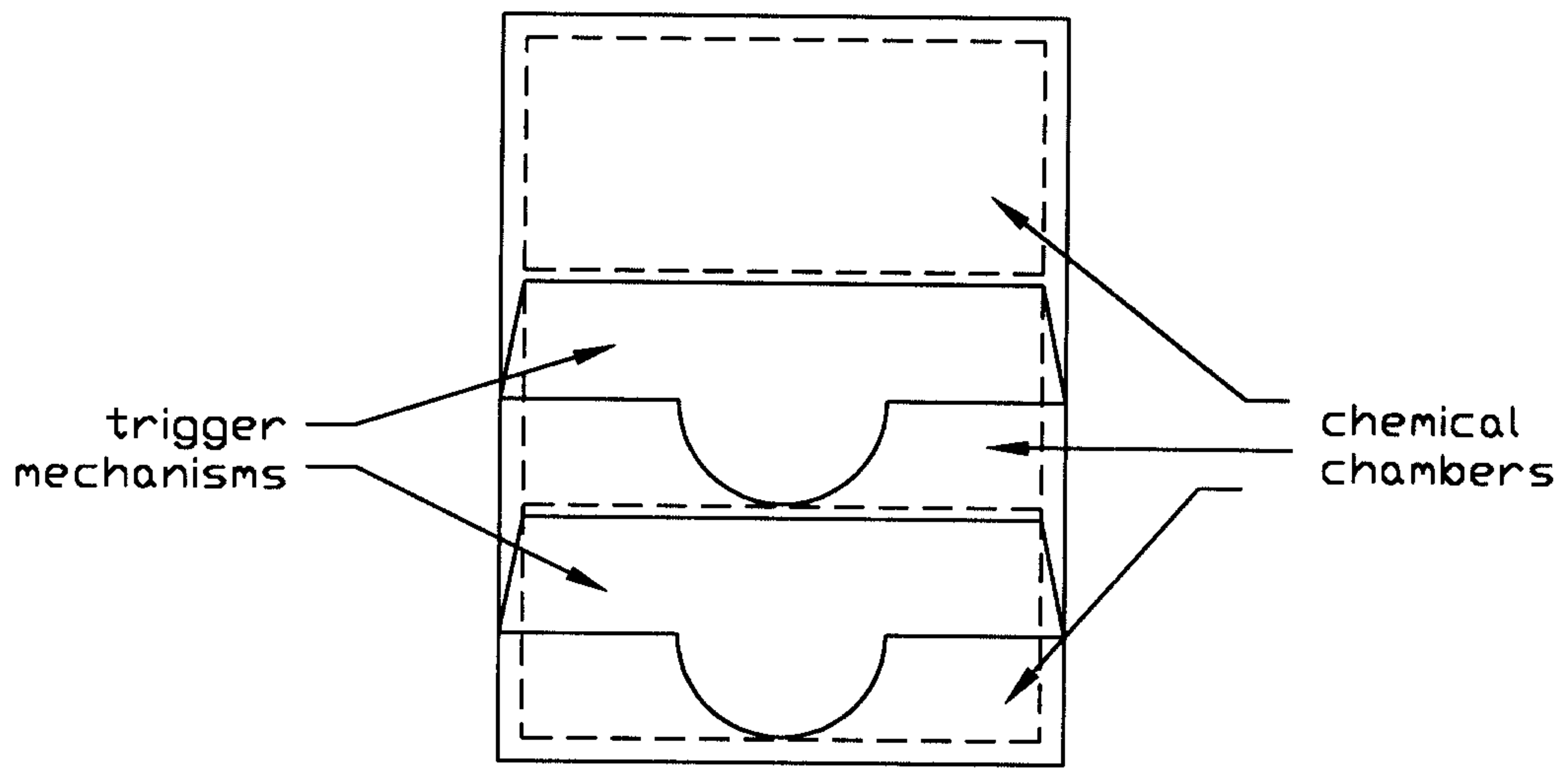

FIGURE 6

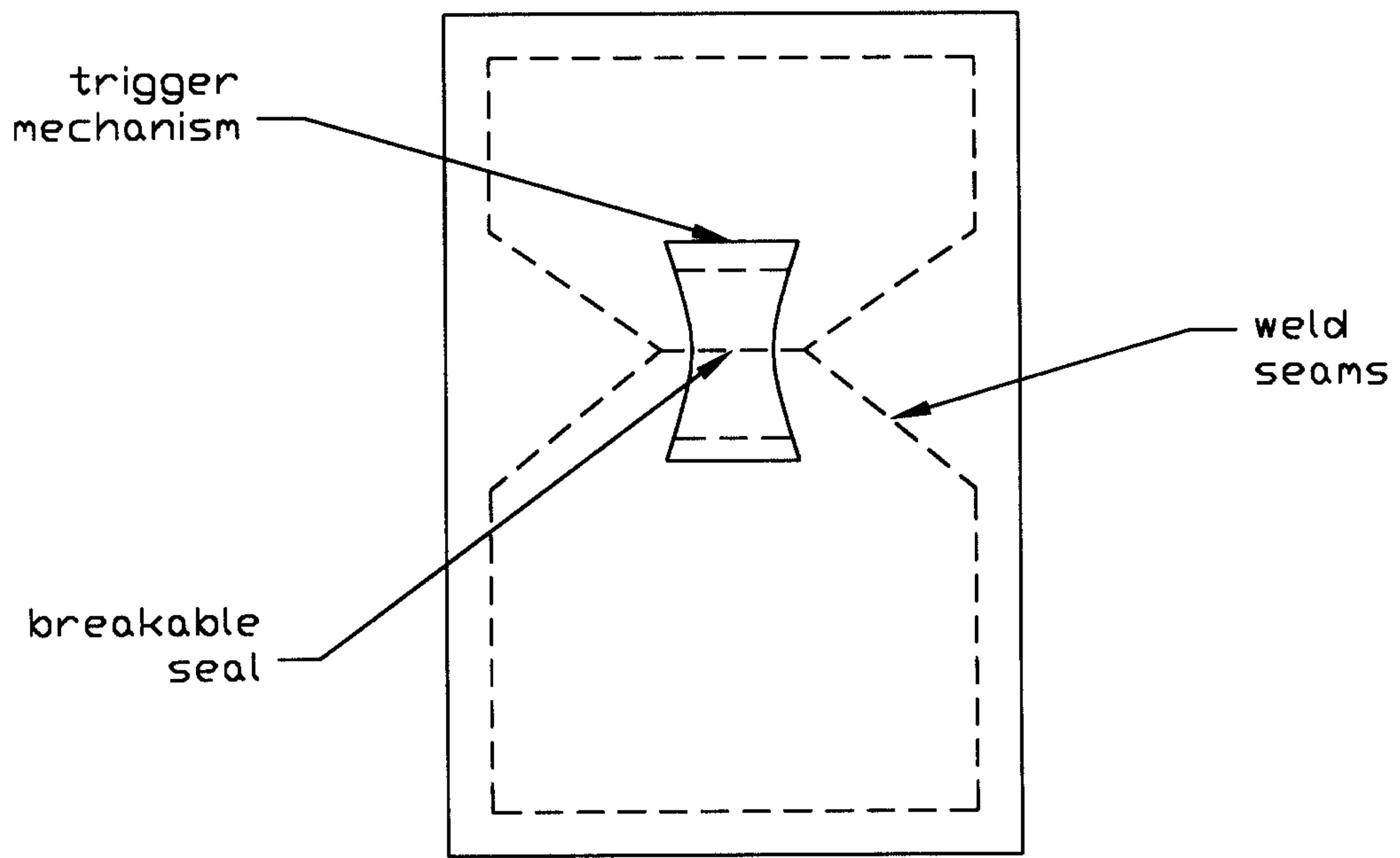

FIGURE 7

