

A U S T R A L I A
Patents Act 1990
COMPLETE SPECIFICATION
FOR A STANDARD PATENT
(ORIGINAL)

Name of Applicant: WINDOW SHUTTER SYSTEM AUSTRALIA PTY.LTD.

Actual Inventor(s): MESIANO, Frank

Address for Service: DAVIES COLLISON CAVE, Patent Attorneys,
1 Little Collins Street, Melbourne, 3000.

Invention Title: Window Units

Details of Associated Provisional Application(s): No(s):

PL9639/93 filed 25 June, 1993

The following statement is a full description of this invention, including the best method of performing it known to me/us:

AUSTRALIA
M
H

WINDOW UNITS

The present invention relates to window units and more particularly to a window unit incorporating a roller shutter.

5

It has been proposed to provide a roller shutter which can be extended in order to cover the exterior face of a window. Such a shutter can provide security protection for the window and may also act to minimise light and heat transmission through the window, although the primary function of such shutters is for security purposes. Normally roller shutters of this general type are installed after installation of the window itself.

10

It is an object of the invention to provide a window incorporating a built-in shutter whereby the window and shutter can be installed as a unit.

15

According to the present invention there is provided a combined window and shutter unit comprising a frame defining a window opening, said shutter being a roller shutter mounted to the frame above the window opening and said frame being defined at each side by vertically-extending stiles, each stile having an integral track for receiving an edge of the shutter, said track lying at an outer side of the frame, each stile also including an integral reveal portion extending perpendicularly to the plane of the frame and lying at the internal side of the frame, said roller shutter being mounted to the frame above the level of the window opening by attachment to the reveal portion of each stile which extends in the frame above the level of the window opening.

20

25

Further according to the invention, there is provided a combined window and security roller shutter unit comprising a window frame including movable and/or fixed window lights, wherein opposed stiles of the frame are extended upwardly beyond the window opening to define supports to which are attached mountings at opposite ends of a roller of a security roller shutter unit, the stiles carrying tracks for the shutter.

30

The term "window" as used herein is also intended to include windows which extend from the floor and are openable to provide access in the manner of a door.

5 Preferably, the reveal portion of each stile is laterally outwardly offset with respect to a part of the stile carrying the track and window guides.

In the preferred embodiment window panels mounted within the frame are sliding panels although it would be possible to design the frame to accommodate a hinged
10 window.

Preferably, the lateral outer edges of each stile lie on a planar surface extending perpendicularly to the plane of the frame to enable two such frames to be mounted in direct side-by-side abutting relationship. In such a configuration the abutting stiles
15 preferably cooperate to define a cavity which can receive a vertically-extending structural supporting column for supporting overlying structure of the building.

An embodiment of the invention will now be described, by way of example only, with reference to the accompanying drawings in which:-

20 Figure 1 is a perspective view from the outside of a window unit in accordance with the preferred embodiment of the invention in its installed condition and illustrating a roller shutter of the unit in a partially extending condition;

Figure 2 is a perspective view of the window unit from the inside;

25 Figure 3 is a section illustrating one of the stiles of the frame and a roller shutter attached thereto; and

Figure 4 is a section of an extrusion which forms each of the stiles of the frame;

In accordance with a preferred embodiment of the invention a combined window
30 and shutter unit comprises a window frame and a security roller shutter mounted to the frame. The shutter comprises substantially rigid interlinked slats, preferably of metal, and

which may contain insulation, the slats being movable from a contracted rolled configuration into an extended configuration in which the slats define a substantially planar surface which covers the window externally. More particularly, the frame comprises opposed vertically extending stiles 2 interconnected at their lower ends by means of a horizontal sill member 4. The stiles 2 are also interconnected by means of a horizontal head member 6 which defines the upper edge of the window opening of the frame. The head member 6 is located beneath the upper ends of the stiles 2, and above the head member 6 the stiles are interconnected by a horizontal member 8 which serves to support a pelmet structure 10 which defines together with the upper part of the stiles 2 above the head member 6 a housing 12 within which is mounted the roller shutter which is designated 14 in Figure 3, the slats of the shutter being designated 16; alternatively or in addition, the pelmet structure 10 can be supported by brackets on the stiles 2.

Each stile 2 is formed from a single member which is preferably in the form of an aluminium extrusion which is clearly shown in Figure 4. The members 4, 6 and 8 are also, preferably, in the form of aluminium extrusions. As shown in Figure 4 the extrusion forming the stile 2 comprises an outer vertical track 18 for receiving an edge of the slats 16 of the roller shutter and, rearwardly of the track 18, guides 20 for receiving window sashes or window lights which can be movable or fixed lights. Rearwardly of the guides 20, a reveal 22 extends at right angles to the plane of the frame to conceal the internal structure of the surrounding opening. The reveal 22 is offset laterally outwardly with respect to the tracks 18 for reasons which will be discussed hereinafter. It is to be noted that the outer lateral edge of the entire stile 2 lies on an imaginary vertical planar surface P (see Figure 4) perpendicularly to the plane of the frame.

As described above the upper edge of the window opening is defined by the head member 6 which extends between the two stiles 2. The two stiles 2 extend upwardly beyond the head member 6 to form a surface to which is attached a mounting member at each end of the roller shutter 14 which extends across the width of the frame. The tracks 18 and guides 20 on the stiles 2 at and above the position of the head member 6 are cut away to facilitate mounting of the roller shutter 14 and also to define an entrance for the

slats 16 into the tracks 18. The roller shutter 14 may be electrically driven by means of a suitable drive motor mounted to one of the stiles above the level of the head member 6. Alternatively the roller shutter 14 may be actuated manually by means of a strap or cord 24 mounted adjacent one end of the roller shutter 14 and passing downwardly through an aperture in the head member 6 to a manual actuating device 26 mounted on the adjacent reveal 22. The mounting members for the shutter are attached to the stiles 2 in the area of the reveals 22, the laterally outwards offset of the reveals 22 serving to accommodate the mounting members which lie outwardly of the roller shutter itself. The lateral outwards offset also facilitates the direct downwards extension of the actuating strap or cord when manual actuation is provided.

The top member 8 and head member 6 form on the internal side of the window frame horizontal tracks for sliding panels 28 which conceal the roller shutter assembly but which can be opened from the inside of the building to provide access for maintenance purposes. The roller shutter assembly is concealed from the outside by the pelmet structure 10 which is supported from the top member 8 and which is also attached to the stiles 2 by means of brackets.

The unit particularly described provides a combined window and shutter which can be installed as a single assembly into an opening. Accordingly the use of separate frames or other sub-assemblies for the roller shutter and window is avoided, thus leading to reduced cost both in manufacture and installation. The configuration of the stiles whereby their lateral outer edges lie on a planar surface enables the unit to be fitted into a simple rectangular opening without the need for any special shaping of the opening. It also enables a number of such window units to be mounted in direct side-by-side relationship. It will be noted that the part of the stile forwardly of the reveal 22 defines an enlarged chamber 30 which is open to the lateral side of the frame. When two such units are placed in side-by-side relationship the adjacent chambers 30 will be in facing relationship to define a relatively large enclosed cavity which extends vertically and is able to receive a steel supporting column which may be necessary for providing structural support in some situations where a wide window opening is provided.

The embodiment has been described by way of example only and modifications are possible within the scope of the invention.

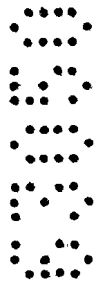

THE CLAIMS DEFINING THE INVENTION ARE AS FOLLOWS:-

1. A combined window and shutter unit comprising a frame defining a window opening, said shutter being a roller shutter mounted to the frame above the window opening and said frame being defined at each side by vertically-extending stiles, each stile having an integral track for receiving an edge of the shutter, said track lying at an outer side of the frame, each stile also including an integral reveal portion extending perpendicularly to the plane of the frame and lying at the internal side of the frame, said roller shutter being mounted to the frame above the level of the window opening by attachment to the reveal portion of each stile which extends in the frame above the level of the window opening.

2. A unit according to claim 1, wherein the reveal portion of each stile is laterally outwardly offset with respect to a part of the stile carrying the track, said laterally outwards offset being considered in relation to the plane of the frame.

3. A unit according to claim 1 or claim 2, wherein the stiles are connected by a horizontal sill member at their lower ends and by a horizontal head member which defines the upper side of the window opening, said head member being attached to the stiles at a position beneath the upper ends thereof whereby to provide above the head member a stile portion of a height to accommodate the roller shutter, and the stiles are connected adjacent their upper ends by an upper horizontal member.

4. A unit according to claim 3, further comprising a pelmet for concealing the roller shutter from the front of the window, said pelmet being supported by the stiles and/or the upper horizontal member and extending downwardly from the top of the stiles substantially to the level of the head member.

5. A unit according to claim 3 or claim 4 comprising at least one panel for concealing the roller shutter from the rear of the window, said panel extending downwardly from the top of the stiles substantially to the level of the head member, said panel being movable to provide access to the roller shutter.

6. A unit according to claim 5, wherein the panel is a sliding panel supported in upper and lower tracks formed, respectively, on the upper horizontal member and the head member.

7. A unit according to any one of claims 1 to 6, wherein each stile consists of an extruded section including guides for the window and the track, the track and guides being removed from the section in the upper part of each stile.

8. A unit according to claim 3 and claim 7, wherein the track extends for a limited distance above the level of the head member.

9. A unit according to any one of claims 1 to 8, wherein the lateral outer edges of each stile, as considered in relation to the plane of the frame, lie on a planar surface perpendicular to the plane of the frame whereby two such frames can be mounted in direct side-by-side abutting relation.

10. A unit according to claim 9, wherein the configuration of each stile is such that when two such frames are in direct side-by-side abutting relation the abutting stiles of the two frames co-operate to define a vertical cavity for receiving a vertical supporting column.

11. A combined window and security roller shutter unit comprising a window frame including movable and/or fixed window lights, wherein opposed stiles of the frame are extended upwardly beyond the window opening to define supports to which are attached mountings at opposite ends of a roller of a security roller shutter unit, the stiles carrying tracks for the shutter.

12. A combined window and shutter unit substantially as hereinbefore described with reference to the accompanying drawings.

DATED this 17th day of April, 1997.

WINDOW SHUTTER SYSTEM AUSTRALIA PTY.LTD.

By his Patent Attorneys:

DAVIES COLLISON CAVE

ABSTRACT

A combined window and security roller shutter unit comprises a window frame in which the stiles of the frame are extended above the level of the window opening to provide a mounting zone for the roller shutter.

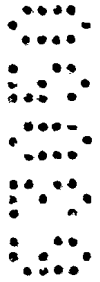

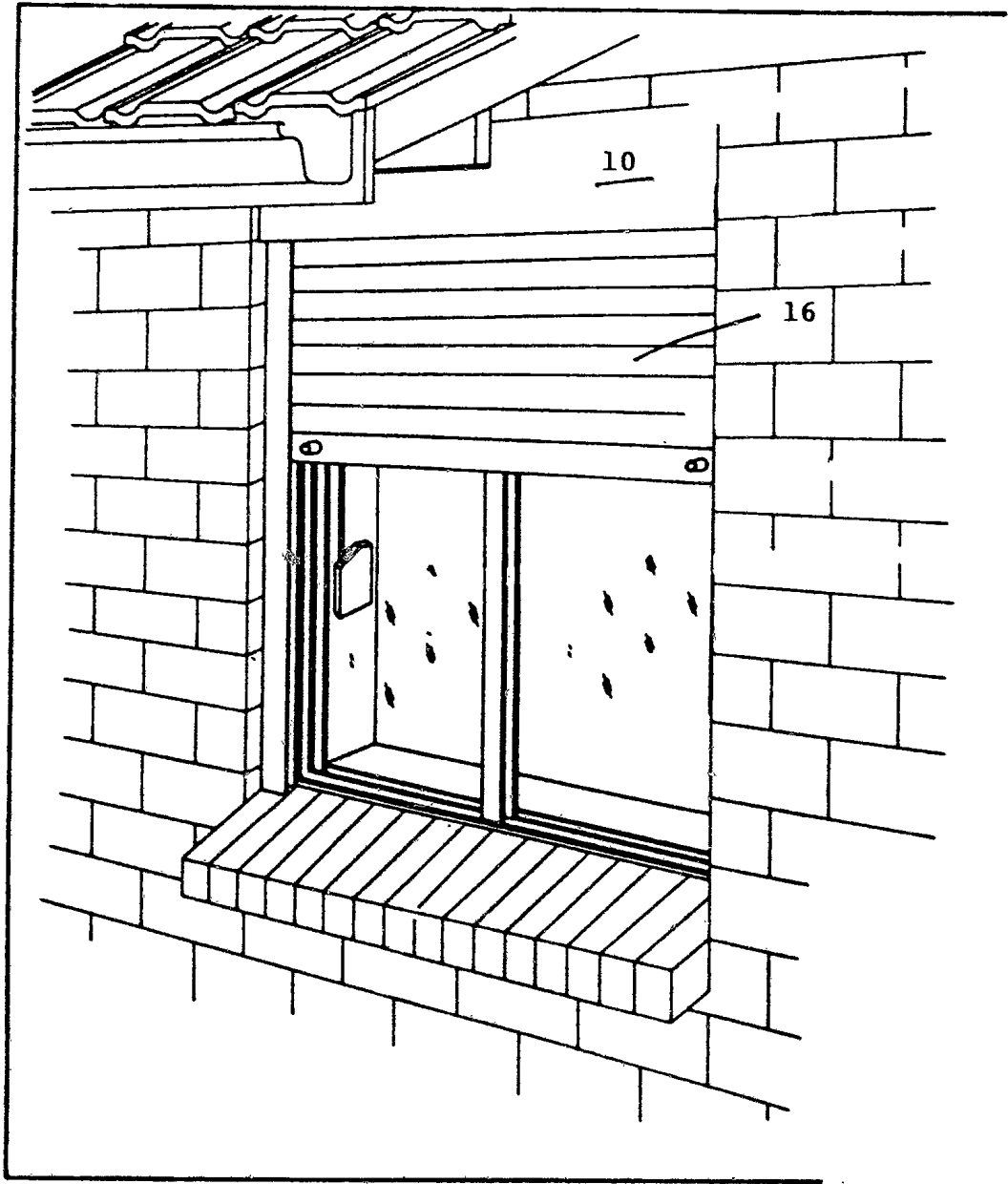

FIG. 1

03050/94

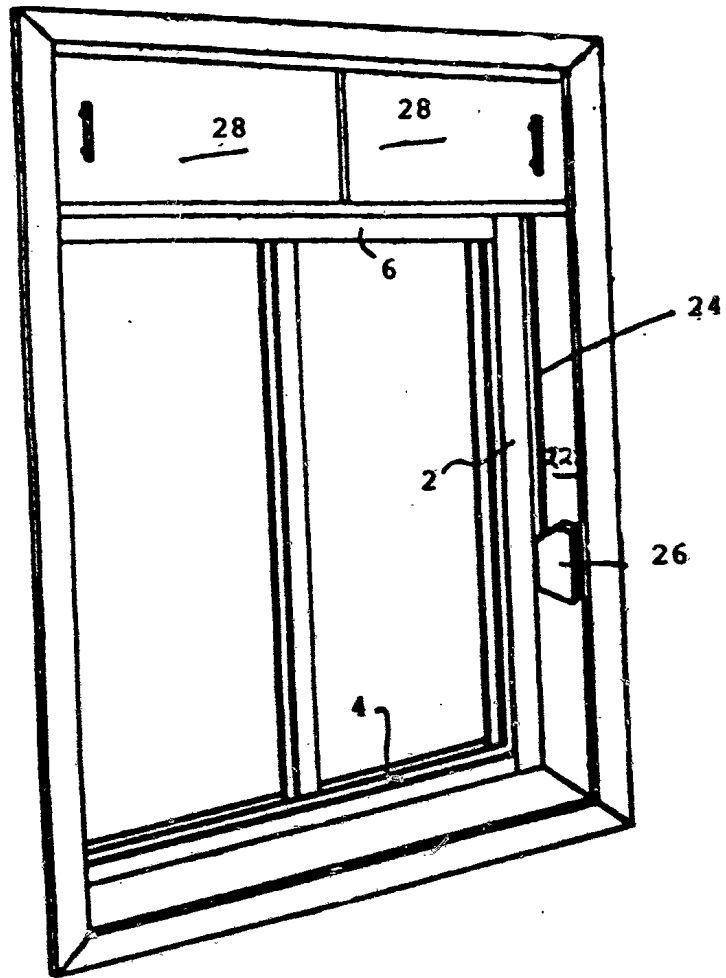
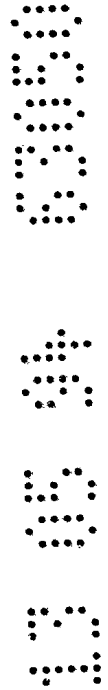

FIG. 2



3/4

63050/94

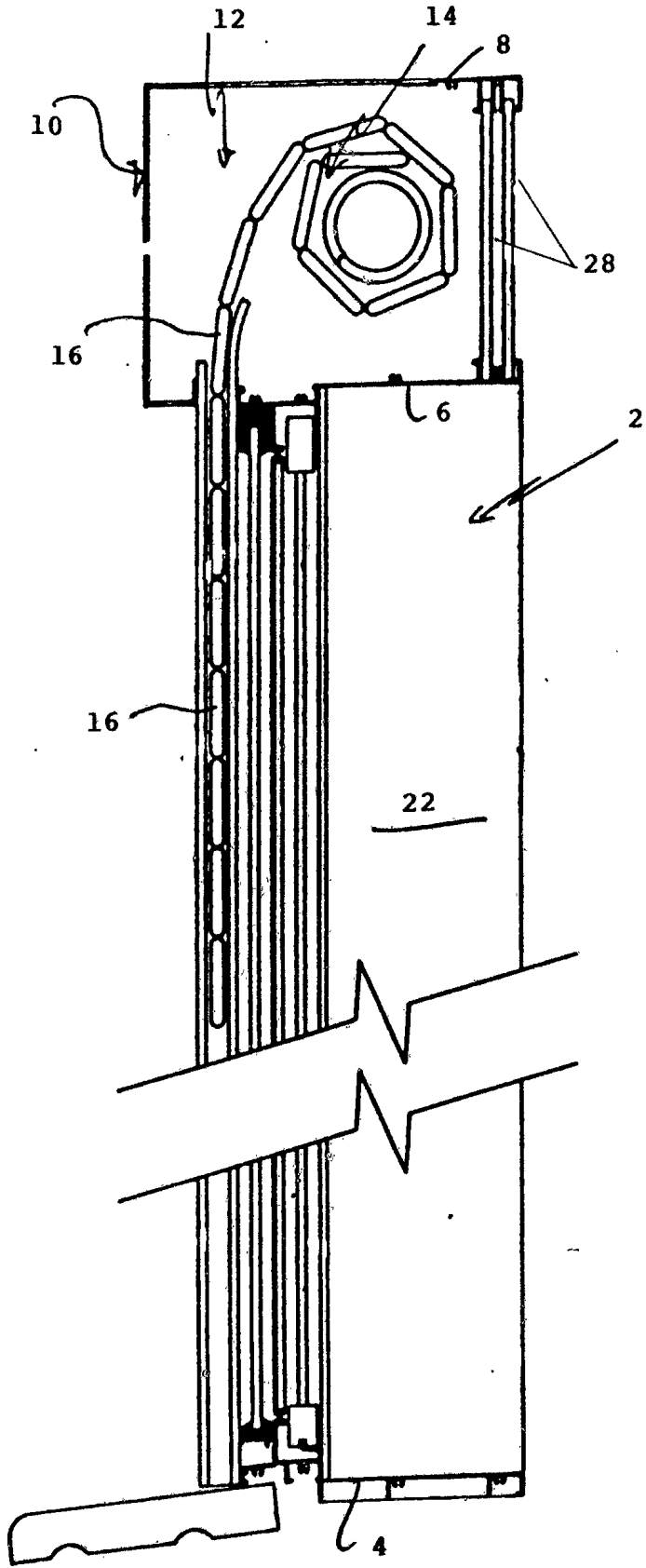

FIG. 3

63050/94

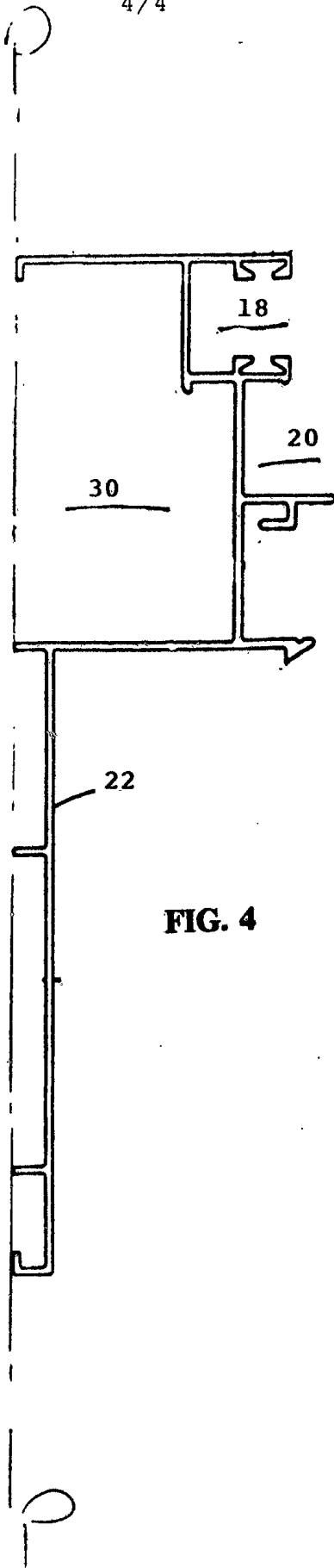

FIG. 4

