

No. 670,030.

Patented Mar. 19, 1901.

H. MEIHSNER & M. AUMANN.
COMB FINISHING MACHINE.

(No Model.)

(Application filed July 9, 1900.)

4 Sheets—Sheet 1.

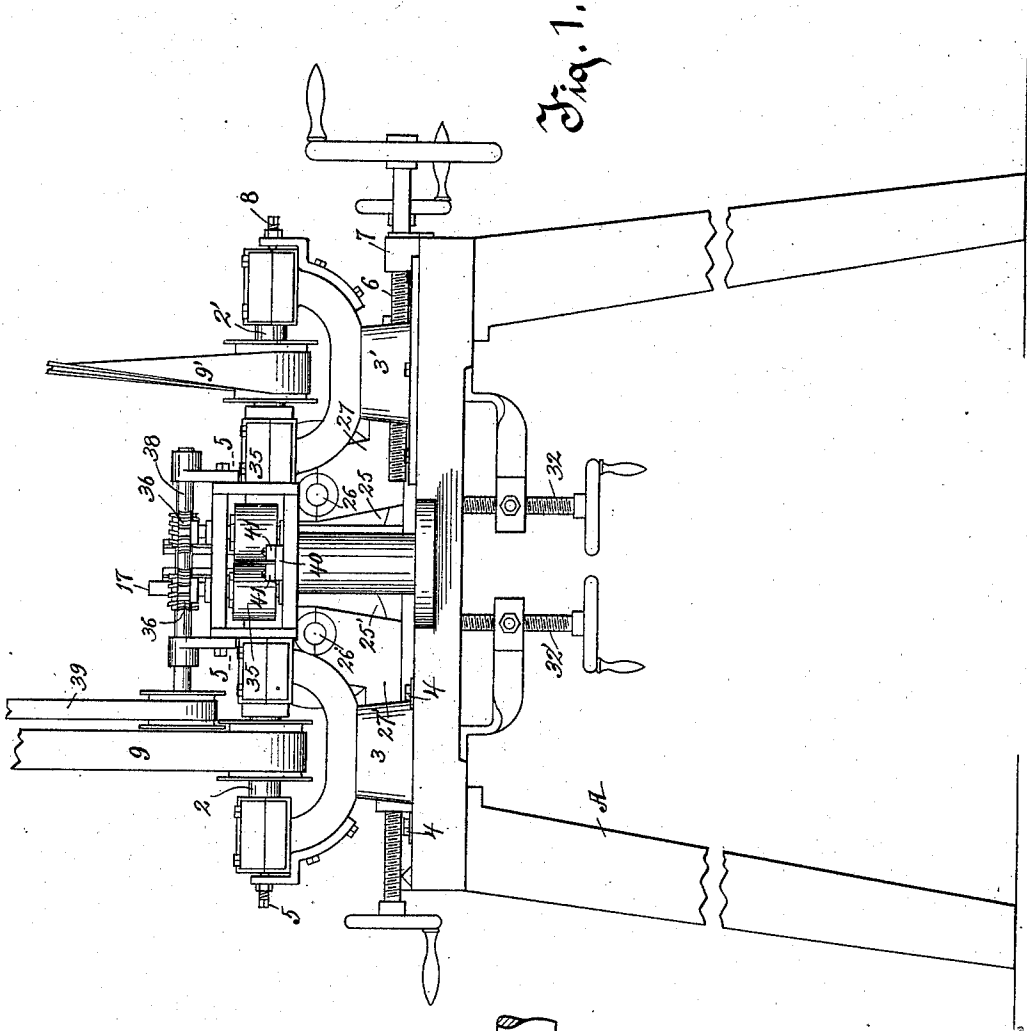

Fig. 1.

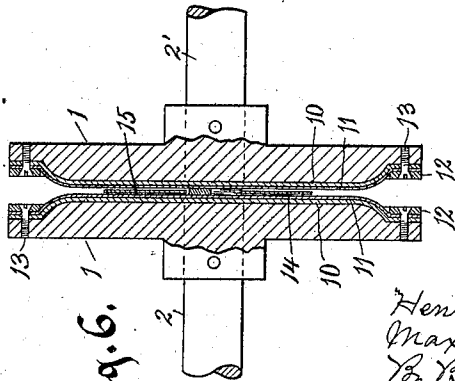

Fig. 6.

Witnesses:
C. H. Keeney
Amos V. Faust

Inventors:
 Henry Meihnsner
 Max Aumann
 By *Beudich & Morsell*
 Attorneys.

No. 670,030.

Patented Mar. 19, 1901.

H. MEIHSNER & M. AUMANN.
COMB FINISHING MACHINE.

(Application filed July 9, 1900.)

(No Model.)

4 Sheets—Sheet 2.

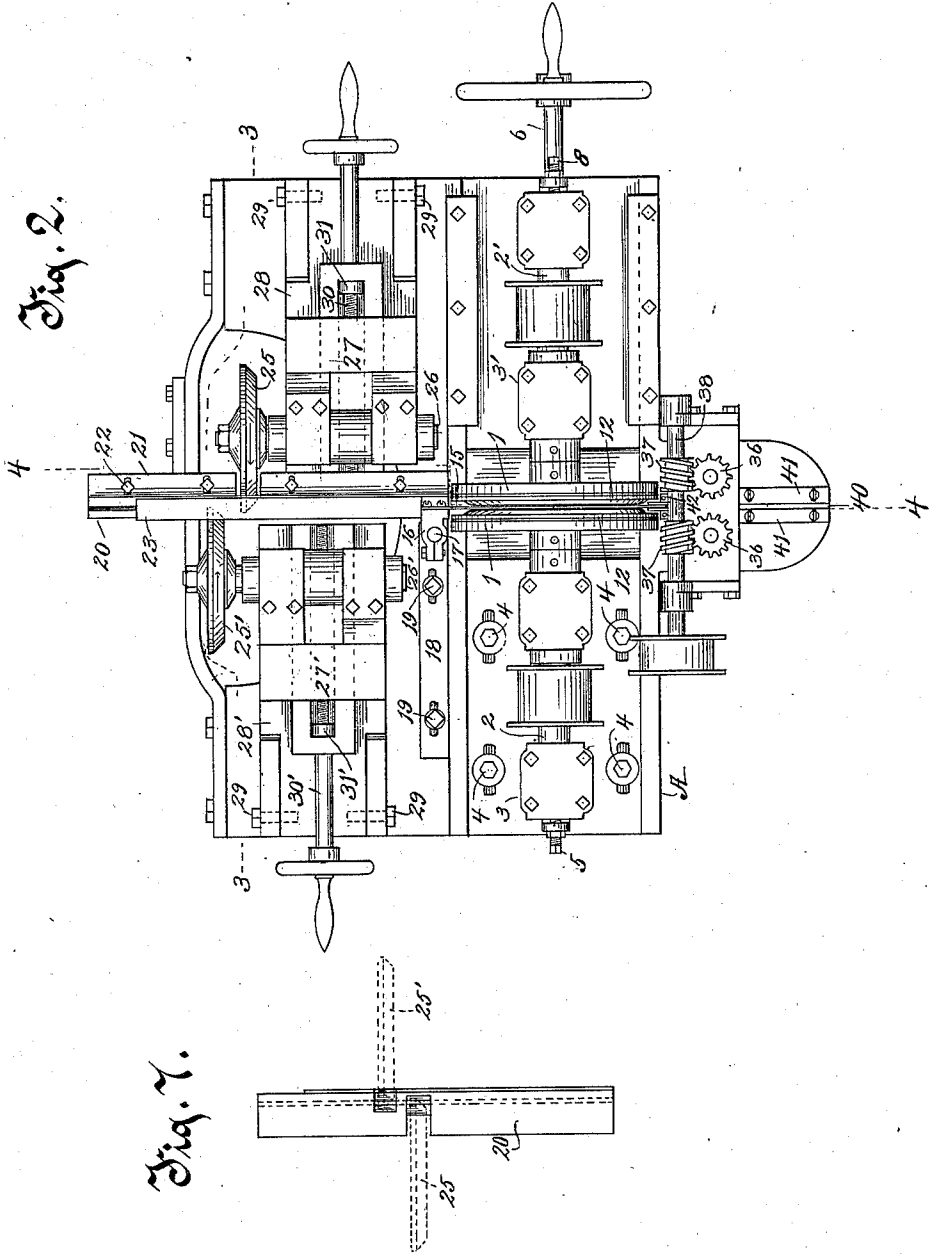

Witnesses:

W. H. Keeney
Anna V. Faust

Inventors:

Henry Meihner
Max Aumann
By *Benedict & Mossell*
Attorneys.

H. MEIHSNER & M. AUMANN.
COMB FINISHING MACHINE.

(Application filed July 9, 1900.)

(No Model.)

4 Sheets—Sheet 3.

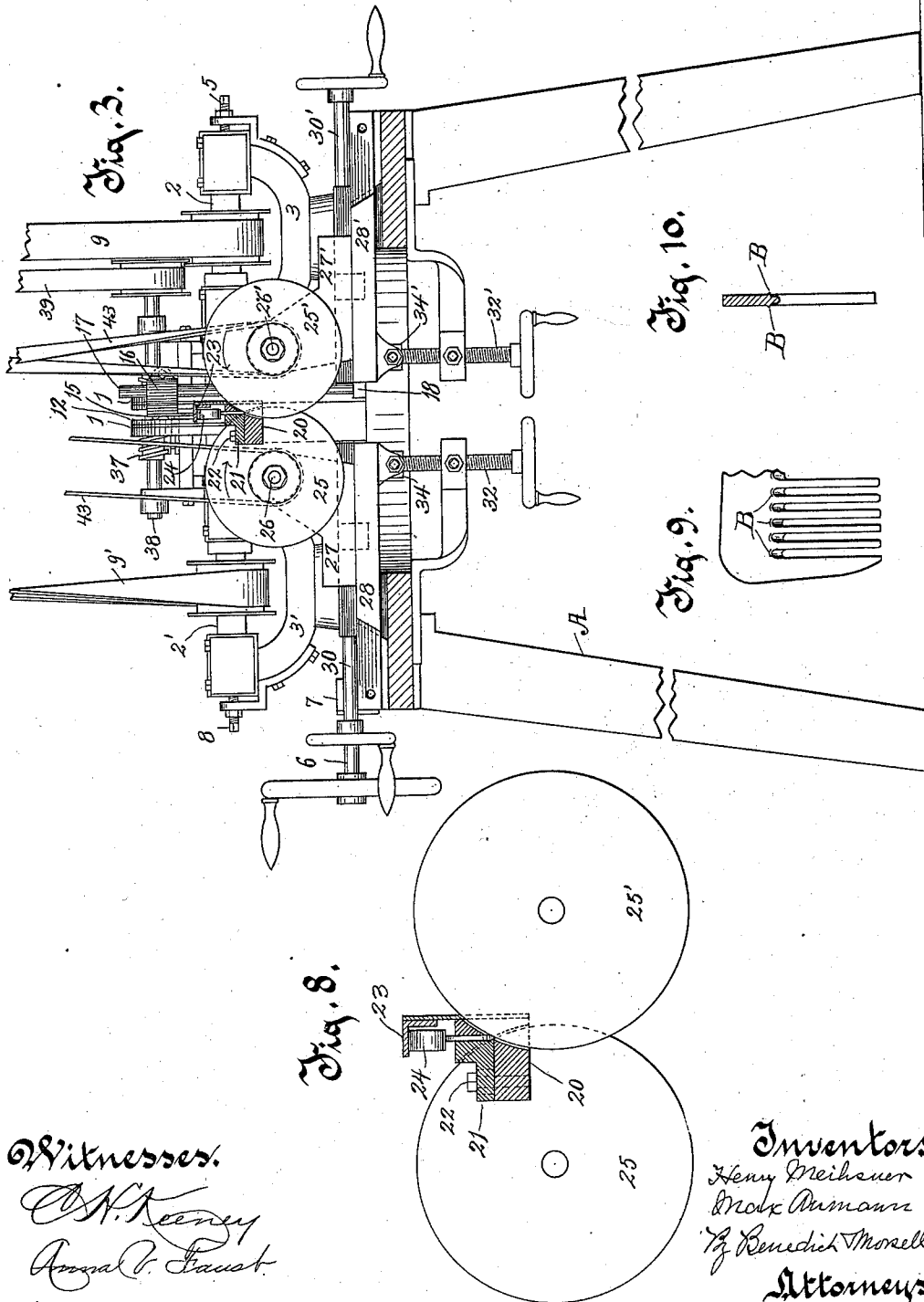

Witnesses:
C. H. Keeney
Amos P. Faust

Inventors:
Henry Meihner
Max Aumann
By Benedict Mosell
 Attorneys:

No. 670,030.

Patented Mar. 19, 1901.

H. MEHSNER & M. AUMANN.

COMB FINISHING MACHINE.

(Application filed July 9, 1900.)

(No Model.)

4 Sheets—Sheet 4.

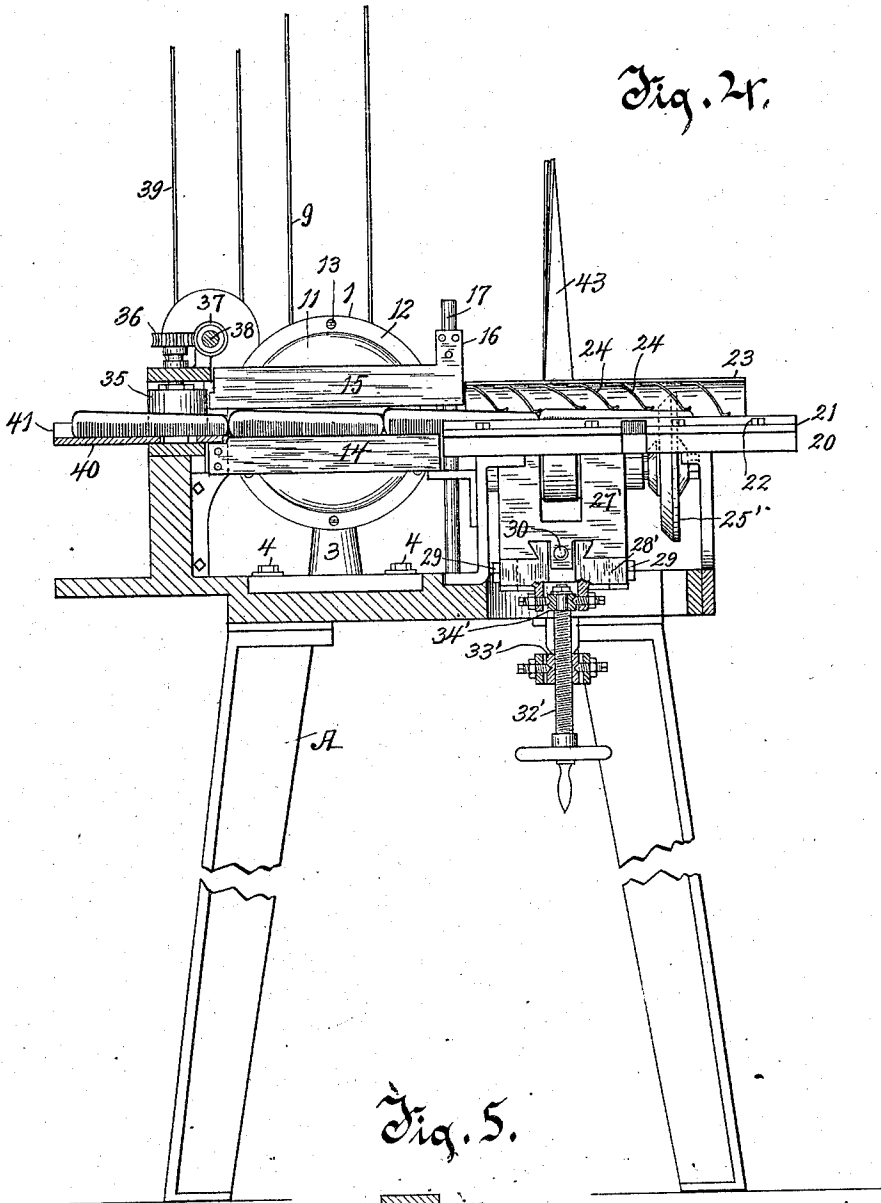

Fig. 2.

Fig. 5.

Witnesses:
C. H. Keene
Amal V. Faust

Inventors:
 Henry Mehsner
 Max Aumann
 By *Benedict & Morrell*
 Attorneys.

UNITED STATES PATENT OFFICE.

HENRY MEIHSNER AND MAX AUMANN, OF MANITOWOC, WISCONSIN,
ASSIGNORS TO MANITOWOC ALUMINUM NOVELTY COMPANY, OF
SAME PLACE.

COMB-FINISHING MACHINE.

SPECIFICATION forming part of Letters Patent No. 670,030, dated March 19, 1901.

Application filed July 9, 1900. Serial No. 22,968. (No model.)

To all whom it may concern:

Be it known that we, HENRY MEIHSNER and MAX AUMANN, residing at Manitowoc, in the county of Manitowoc and State of Wisconsin, have invented a new and useful Improvement in Comb-Finishing Machines, of which the following is a description, reference being had to the accompanying drawings, which are a part of this specification.

The object of our invention is to provide an improved machine adapted for removing burs from and smoothing the sides and pointing the teeth of metal combs. The burs on the combs that our machine is adapted to remove are those formed on the sides of the comb in the process of the manufacture of the combs at the inner ends of the saw-cuts between the teeth, and these in our machine are removed by the same means that are employed for smoothing the sides of the comb.

In the drawings, Figure 1 is an elevation of our improved machine at the front. Fig. 2 is a top plan view of the same machine. Fig. 3 is an elevation of the machine at the rear, the frame and the comb-runway being in section on line 3 3 of Fig. 2. Fig. 4 is a section of the machine on line 4 4 of Fig. 2, except that the runway adjacent to the tooth-pointing wheels is shown complete. The view also shows combs in place passing through the machine. Fig. 5 is a detail in section on line 5 5 of Fig. 1, showing the feed-rolls and related parts. Fig. 6 is a transverse section of the abrading and smoothing disks. Fig. 7 is an under side view of the main comb-runway, the pointing-wheels being indicated by dotted lines. Fig. 8 illustrates in enlarged form parts shown in the middle foreground in Fig. 3. Fig. 9 shows a fragment of an unfinished comb with burs thereon that are to be removed by our machine. Fig. 10 is a transverse section of the unfinished comb, a fragment of which is shown in Fig. 9.

Our improved machine embodies mechanism, first, for removing the burs hereinbefore mentioned from the sides of metal combs and for smoothing and to a certain extent polishing the sides of the combs, and, second, mechanism for pointing the teeth of the combs

in connection with means for automatically feeding the combs through the machine.

In the drawings, A is a frame of suitable size and form for supporting the operative mechanism.

For removing the burs before mentioned and for smoothing the sides of metal combs we provide two abrading-disks 1 1, which disks are mounted, respectively, terminally on shafts 2 2'. The shafts and disks are so constructed and mounted that the disks are opposite and complementary to each other, with only a space between them substantially equal to the thickness of a comb. The shafts are mounted, respectively, in standards 3 3', resting on the bed of the frame. The base of the standard 3 is secured adjustably on the bed of the frame by bolts 4 4 through elongated slots in the base of the standard and through the bed. A set-screw 5, turning through a part of the standard 3 against the outer end of the shaft 2, is adapted to take up wear and hold the disk thereon up to its work. The standard 3' is slidable in ways therefor on the bed of the frame and is shiftable in those ways by means of a screw 6, rotatable without movement end wise in a block 7, forming a part of the frame, which screw turns by its thread through the standard 3'. By this construction the disk mounted on the standard 3' can be withdrawn from the vicinity of its complementary disk for the purpose of renewing the abrading-surfaces on the disks. A set-screw 8, turning through a part of the standard 3' against the end of the shaft 2', is adapted to take up wear and hold the disk thereon up to its work. The disks are rotated in reverse directions by belts 9 9', one open and the other crossed, running on pulleys therefor on the shafts 2 2'. The disks 1 1 are preferably constructed with removable abrading-surfaces, and for this purpose the peripheral margins of the disks are removed or set back from the planes of the faces of the disks, and each disk is covered with a cushion 10, of felt or other suitable material, and with emery-paper 11 over the cushion, the emery-paper and the cushion being held securely but detachably in place on the

disk by means of a flat ring 12, placed thereon and held to the disk by screws 13.

For supporting the combs in position while being passed between the abrading-disks 1 1 a plate 14 of less thickness than the thickness of the combs is secured on the frame and extends in the space between the disks 1 1, from edge to edge thereof, one edge of the plate being exposed upwardly and forming the bottom of the runway on which the combs travel past the disks. At a distance above the plate 14 another thin plate 15 extends in the space between the disks, from edge to edge thereof, and this plate is provided with a clamp 16, adjustable vertically on a post 17, which post is fixed in a footpiece 18, that rests on the bed of the frame and is adjustable thereon in the direction of the length of the shaft 2 by means of bolts 19 through slots in the footpiece and through the bed of the frame. The plate 14, serving as a bottom, and the plate 15, serving as a top, form an intermediate runway for the combs, the combs while passing these plates being held in upright position by the disks 1 1 at the sides thereof.

After the burs have been removed from the combs and the sides of the combs have been smoothed and to some extent polished by the disks 1 1 the combs are pushed forward from between the disks into the main runway, in which by suitable means the teeth are pointed. The main runway is conveniently constructed of an elongated piece of angle iron or steel 20, forming the bottom and one side of the runway, and another angle-iron 21, of smaller dimensions in cross-section, forming the other wall of the runway. The member 21 is secured on the member 20 by screws 22 through laterally-elongated slots therefor in the member 21 and turning into the member 20. The two angle-irons 21 and 20 are so arranged with reference to each other that a channel or runway is formed between their vertical walls for the passage of the combs. At a little distance above the channel thus formed a plate 23 (in the drawings shown as an angle-iron) is supported on the frame, and this plate is provided with a number of elastic fingers or springs 24, the free ends of which are adapted to bear against the backs or top edges of the combs as they are pushed forward on the runway, holding the combs down to the floor of the runway. Medially of this runway there are located the teeth-pointing wheels 25 25'. These wheels are respectively mounted on the arbors 26 26' terminally, and the wheels are so disposed that they enter transverse recesses made therefor in the main runway, one wheel 25 being located in advance of the other wheel 25' along the path of the movement of the combs. These wheels are of any suitable abrading material, preferably of emery, and the perimeters are advisably so beveled as to present an oblique grinding-surface to the tooth-

formed edge of the comb as it comes thereto on the runway. The wheels are located one at each side of the runway and are so disposed with reference thereto as to be adapted properly to point the teeth, beveling them off at the two sides thereof by grinding as the combs pass them. The arbors are rotated by the belts 43 43' running thereon, one of which is open and the other is crossed. The arbors 26 26' for the purpose of adjusting the wheels to their work and for the purpose of withdrawing the wheels for repairs or replacing them by unworn wheels are mounted, respectively, in arbor-frames 27 27'. These arbor-frames are reciprocable toward and from each other on ways therefor on the auxiliary frames 28 28'. These auxiliary frames are pivoted on the main frame by pins 29 29 in such manner that the arbors, with the wheels 25 25' thereon, can be lifted from their normal positions without detaching them from the frames. The arbor-frames 27 27' are adjustable on the auxiliary frames 28 28 by means of screws 30 30', which pass revolubly through a part of the main frame and are provided with collars 31 31', that bear against the frame and prevent endwise movement of the screws, the screws turning by their threads into parts of the frames 27 27'. For raising or lowering the auxiliary frames 28 28', and thereby adjusting the wheels 25 25', we provide screws 32 32', which turn through nuts 33 33', pivoted in members of the frame, which screws are provided with blocks 34 34', journaled on the ends thereof and pivoted in ears on the under sides of the free ends of the frames 28 28'. The screws 32 32' are provided with cranks, whereby they are conveniently rotated.

For feeding combs into and through the machine a pair of feed-rolls 35 35, in upright position, are located in front of the disks 1 1. These rolls are journaled in the frame and are provided with worm-wheels 36 36, that mesh with reversely-disposed worms 37 37 on a shaft 38, journaled in the frame and provided with a belt-pulley, on which the belt 39 runs for driving the feed-rolls. The feed-rolls are advisably made of leather or are covered with leather to furnish a suitable surface for contact with the combs as they pass between the rolls. An initial runway in front of and past the feed-rolls consists of a bottom plate 40, secured to the frame, and side strips 41 41, placed on and secured to the bottom member 40, the side strips being at such distance apart as permits of the passage of combs endwise between them. These strips are advisably secured adjustably on the bottom 40 by means of screws through the side strips in slots slightly elongated laterally therefor. The elongations of these slots are so slight that they are not apparent in the drawings on the scale at which the drawings are made. At the rear of the feed-rolls there are other devices that form a part of the initial runway, which devices consist of blocks 42 42, secured

to the frame, these blocks being provided with oppositely - disposed guides, between which combs may pass, the guides being in effect the sides of the runway, serving at the rear of the feed-rolls, as the members 41 do in front of the feed-rolls, as the sides of the initial comb-runway.

In Figs. 9 and 10 an unfinished comb is illustrated on which burs B B are shown of the character that are removed by the disks 11 of this machine.

What we claim as our invention is—

1. In combination, a pair of oppositely-disposed adjacent rotatable disks, a runway-bottom 14 between the disks from edge to edge thereof, and a top to the runway between and across the disks at a distance above the runway-bottom.

2. In combination, a pair of oppositely-disposed adjacent rotatable disks, a runway-bottom 14 between the disks from edge to edge thereof, and a plate 15 adjustable vertically between and across the disks at a distance above the bottom of the runway adapted to serve as an adjustable top to the comb-runway.

3. In combination, a pair of oppositely-disposed adjacent rotatable disks adapted to smooth the sides of combs, a comb-runway between and past said disks and continuing beyond the disks, and a set of comb-pointing wheels respectively at opposite sides of and intersecting the runway in recesses therefor in transverse planes one being in advance of the other in the path of the travel of combs along the runway.

4. In combination, a comb-runway including a bottom and side walls and elastic fingers or springs adapted to bear yieldingly against the back edge of combs passing along said runway, and abrading - wheels respectively on the two sides of the runway and projecting in different transverse planes into the comb-runway and adapted to point the teeth of combs passing along the runway.

5. A comb-runway, comprising an angle-iron forming the bottom and one side of the

runway, a second angle-iron fitting in the bottom angle-iron, means securing the second angle-iron adjustably to the bottom angle-iron, and flat strap-springs adapted to bear against the back edge of combs in the angle-iron runway.

6. In combination, a main frame, duplicate auxiliary frames substantially opposite each other and severally pivoted on the main frame near their outer ends, arbor-frames adjustable on the auxiliary frames, arbors severally journaled in the arbor-frames, and abrading-wheels mounted in transverse planes on said arbors and so as to be swung away from each other upwardly by the uptilting of the auxiliary frames.

7. In combination, a main frame, an auxiliary frame pivoted on the main frame, a screw turning in a block trunnioned in the main frame, said screw having a thereto-swiveled block trunnioned in said auxiliary frame, an arbor-frame adjustable on the auxiliary frame, and a wheel-carrying arbor mounted in the arbor-frame.

8. In combination, an initial comb-runway, comb-feeding devices, oppositely-disposed abrading-disks adapted to smooth the sides of combs passing between them, a main comb-runway, and comb-pointing abrading-wheels in planes transverse to and entering said main runway.

9. In combination, a pair of oppositely-disposed upright feed-rolls, means for rotating the rolls in reverse directions, and an initial comb-runway comprising a bottom and side pieces in front and at the rear of the feed-rolls forming a channel or runway adapted to support combs in front and at the rear of the feed-rolls while being fed between the rolls.

In testimony whereof we affix our signatures in presence of two witnesses.

HENRY MEIHSNER.

MAX AUMANN.

Witnesses:

L. A. SCHMITZ,

HUGO VITS.