

R. S. CATHCART.
Shaft-Couplings.

No. 143,879.

Patented Oct. 21, 1873.

Fig. 1.

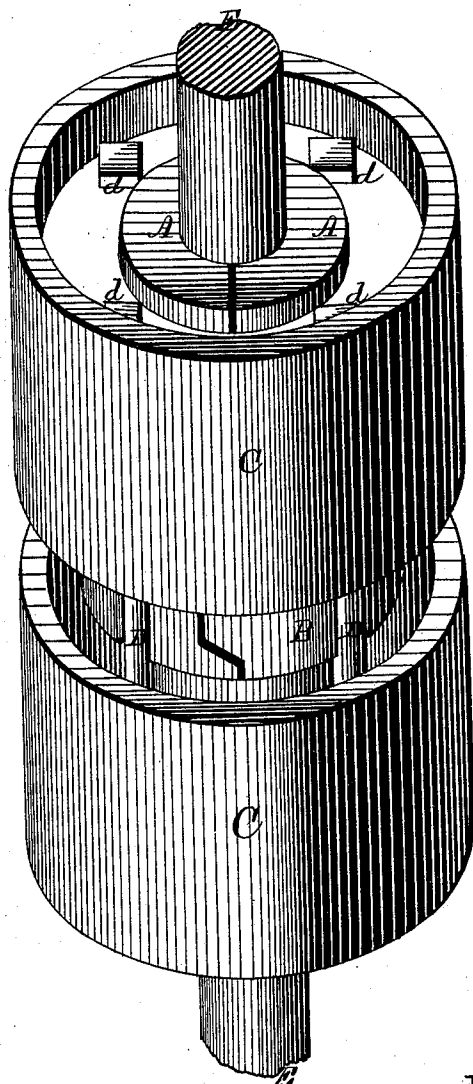

WITNESSES:

*Jas. C. Hutchinson
 John R. Young*

INVENTOR.

*R. S. Cathcart, by
 Prindle and Co., his Attys.*

R. S. CATHCART.
Shaft-Couplings.

No. 143,879.

Patented Oct. 21, 1873.

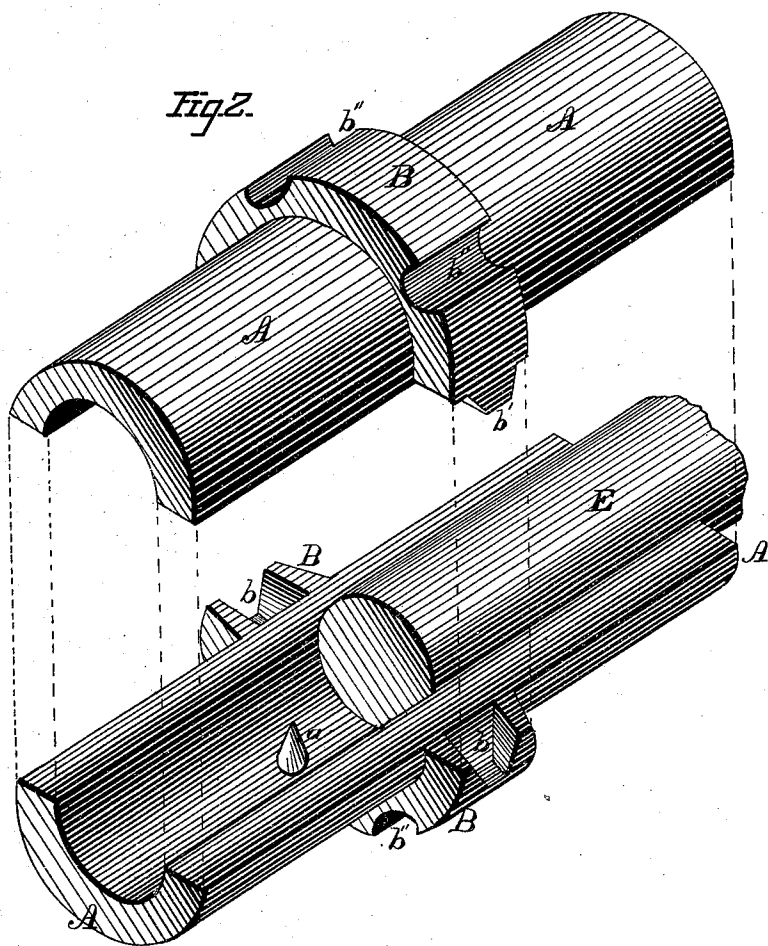

Fig. 2.

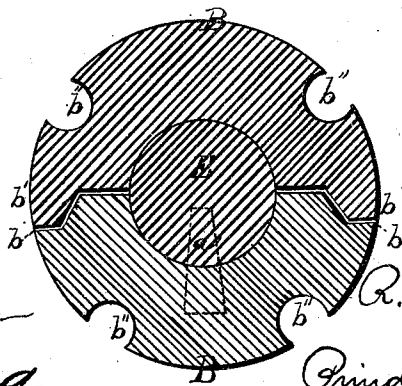

Fig. 3.

WITNESSES:

*Jas. C. Hutchinson
 John R. Young*

INVENTOR.

*R. S. Cathcart, by
 Prindle and Co., his Attys*

R. S. CATHCART.
Shaft-Couplings.

No. 143,879.

Patented Oct. 21, 1873.

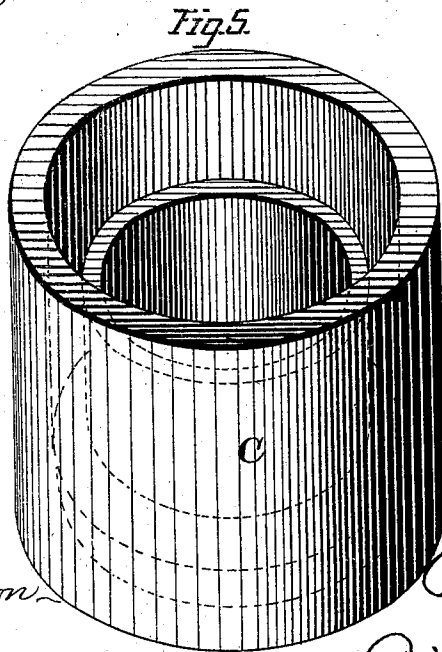
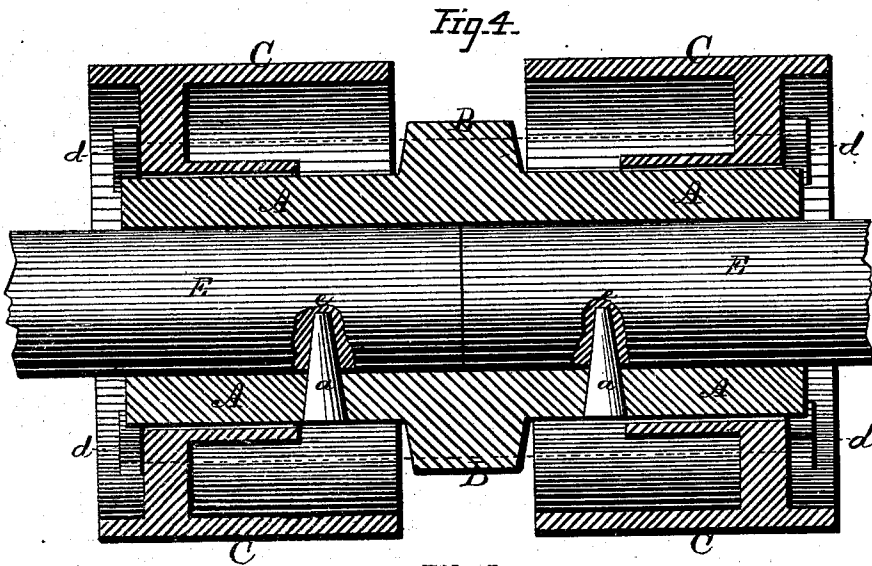

WITNESSES:

James E. Hutchinson
John R. Young

INVENTOR.

R. S. Cathcart, by
Orindle and Co., his Attys

UNITED STATES PATENT OFFICE.

RODNEY S. CATHCART, OF CINCINNATI, OHIO.

IMPROVEMENT IN SHAFT-COUPPLINGS.

Specification forming part of Letters Patent No. 143,879, dated October 21, 1873; application filed August 11, 1873.

To all whom it may concern:

Be it known that I, RODNEY S. CATHCART, of Cincinnati, in the county of Hamilton and in the State of Ohio, have invented certain new and useful Improvements in Shaft-Couplings; and do hereby declare that the following is a full, clear, and exact description thereof, reference being had to the accompanying drawings making a part of this specification, in which—

Figure 1 is a perspective view of my device, as applied to the abutting ends of two pieces of shafting. Fig. 2 is a like view of the divided clamping-sleeve, showing the sections separated. Fig. 3 is a cross-section of said parts upon a central line. Fig. 4 is a central longitudinal section of the complete coupling, and Fig. 5 is a perspective view of one of the locking-collars.

Letters of like name and kind refer to like parts in each of the figures.

The object of my invention is to enable pieces of shafting to be easily and securely connected, and as readily disconnected, when desired, to which end, it consists, principally, in the peculiar construction of the sections of the clamping-sleeve, and their combination with each other, and with the contiguous ends of the shafts, substantially as and for the purpose hereinafter specified. It consists, finally, in the coupling as a whole, when its several parts are constructed as described, and combined with each other and with the shaft ends in the manner and for the purpose substantially as set forth.

In the annexed drawings, A and A' represent two semi-cylindrical pieces of metal which have corresponding dimensions and are provided with half-round grooves within their inner or plane faces, so that when placed together they form a sleeve that has an interior opening which corresponds in size and shape to the like features of the shafts to be coupled. Exteriously the sleeve has a slight and regular increase from its ends inward toward its longitudinal center, at which latter point is provided a collar, B, that has, preferably, a radial diameter equal to the thickness of one wall of said sleeve, and a breadth of about one-half inch. Within the plane faces

of one portion of the collar B are provided two conical recesses, *b*, while upon the opposite portions of the other section of said collar are two spurs, *b'*, that correspond to and fit into said recesses and hold the sections of the sleeve in relative position. Fitting over each end of the sleeve A is a collar, C, which interiorly has the same taper as is given to the exterior of said sleeve, and has such dimensions that, when pressed inward until its inner edge nearly reaches the longitudinal center of the latter, said collar shall firmly press together the sections forming the same. Two or more bolts, D, passing horizontally through the collars C, and provided upon their ends with nuts *d*, enable said collars to be drawn toward each other, so as to compress the divided sleeve A. Suitable half-round grooves *b''*, formed within the collar B, enable said bolts to be placed in position, and, at the same time, insure the relative circumferential positions of said parts. The shafts E are each provided, near their ends, with a round opening, *e*, which receives a correspondingly-shaped stud, *a*, that projects radially inward from the inner side of one of the sections, the relative positions of said studs and openings being such as to cause the end of each shaft to be held at the longitudinal center of said sleeve.

The device is now complete, and is used as follows: The ends of the shafts are brought together and turned until their openings *e* are in a line so as to receive the studs *b''* of the sleeve; said sleeve is then placed in position, and the collars, which have previously been slipped over the shafts, pressed over said sleeve and secured by the binding-bolts, the whole operation occupying but a few minutes of time, and being easily accomplished.

In construction the coupling is so simple, and its parts are so few, as to render its cost comparatively small, while for strength and durability the device will compare favorably with any in use.

Having thus fully set forth the nature and merits of my invention, what I claim as new is—

1. The sections A and A', provided with studs *a*, the collar B, the recesses *b*, and the spurs *b'*, in combination with each other and

with the shaft ends E, provided with the openings e, substantially as and for the purpose specified.

2. The sleeve A, constructed in interlocking sections, as shown, and provided with the studs a, the collars C and C, fitted upon or over said sleeve, and the bolts D passing through said collars, combined with each other, and with the shafts E provided with the open-

ings e, substantially as and for the purpose set forth.

In testimony that I claim the foregoing I have hereunto set my hand this 8th day of August, 1823.

RODNEY S. CATHCART.

Witnesses:

GEO. E. GAULT,
W. E. WATSON.