

April 11, 1939.

J. D. KARLE

2,154,403

ROTARY HOOK SEWING MACHINE THREAD CASE

Filed April 14, 1938

2 Sheets-Sheet 1

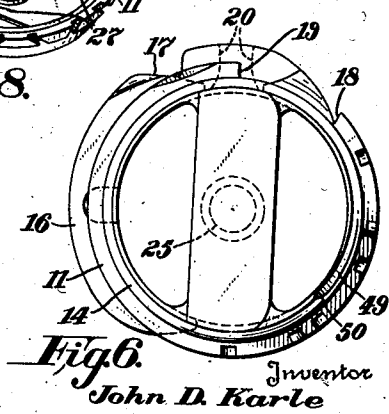
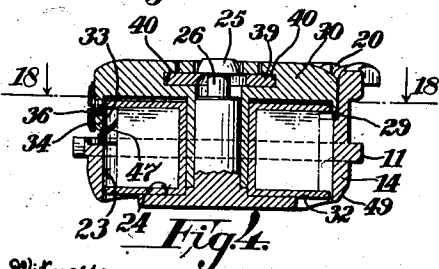
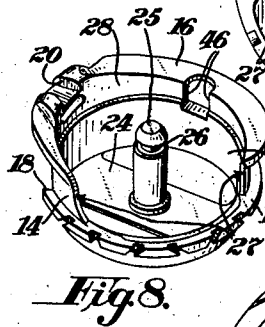
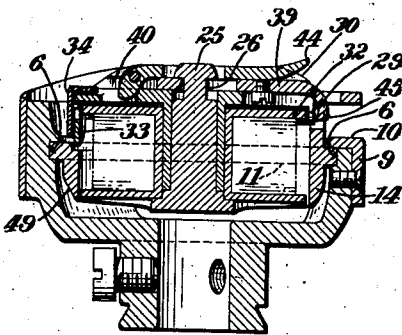
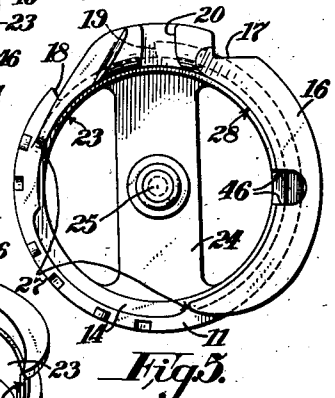
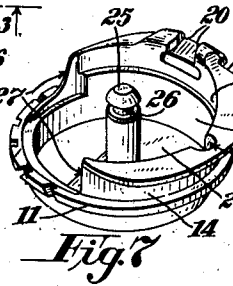
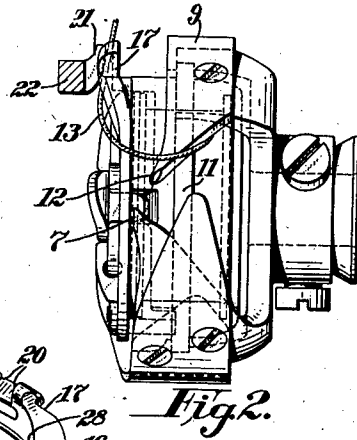
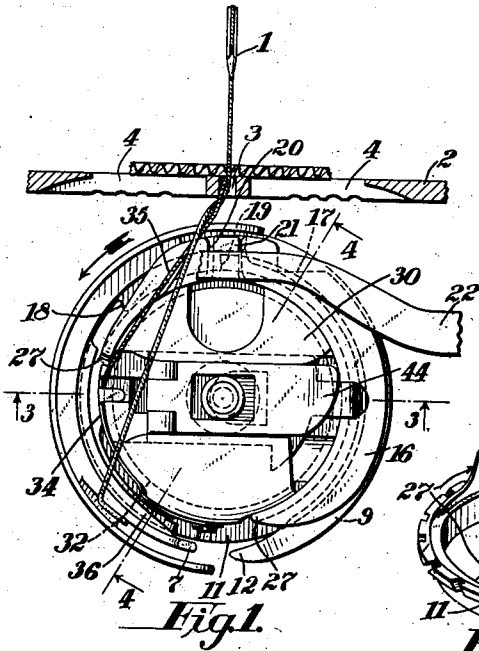

Witness:

John H. Cave

By Henry J. Miller

Attorney

April 11, 1939.

J. D. KARLE

2,154,403

ROTARY HOOK SEWING MACHINE THREAD CASE

Filed April 14, 1938

2 Sheets-Sheet 2

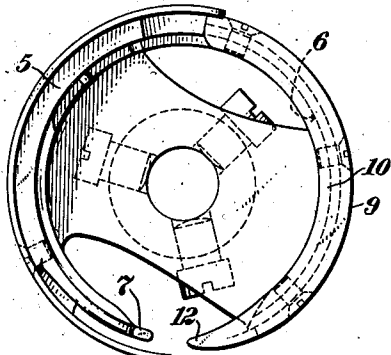

Fig. 9.

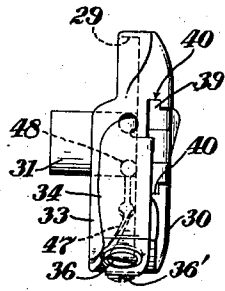

Fig. 12.

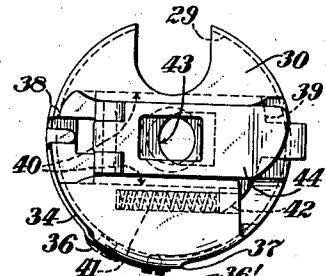

Fig. 11.

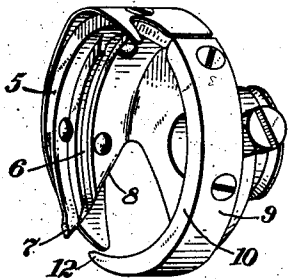

Fig. 10.

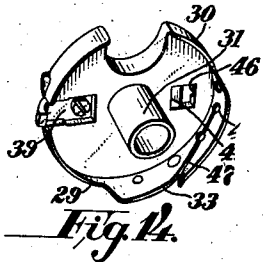

Fig. 14.

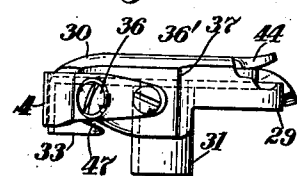

Fig. 13.

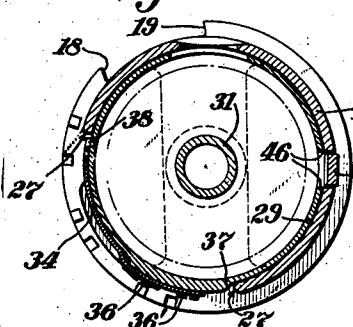

Fig. 18.

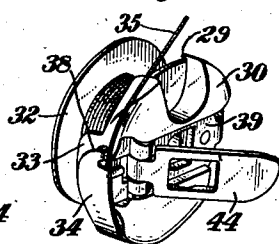

Fig. 15.

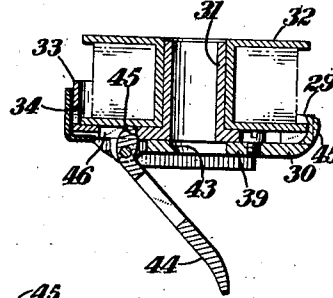

Fig. 16.

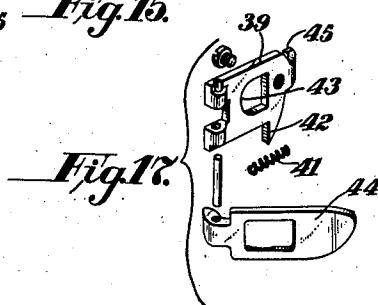

Fig. 17.

Witness:

John N. Cave

Inventor
John D. Karle

By Henry J. Miller

Attorney

UNITED STATES PATENT OFFICE

2,154,403

ROTARY HOOK SEWING MACHINE THREAD CASE

John D. Karle, Roselle Park, N. J., assignor to
The Singer Manufacturing Company, Elizabeth, N. J., a corporation of New Jersey

Application April 14, 1938, Serial No. 291,893

7 Claims. (Cl. 112-231)

This invention relates to sewing machine thread-case devices such as are commonly used with needle-thread loop-takers of the rotary hook type disclosed, for example, in U. S. Patents No. 1,125,669, dated Jan. 19, 1915, No. 1,995,278, dated Mar. 19, 1935, and No. 2,085,699, dated June 29, 1937.

Thread-cases of the type disclosed in the above cited patents comprise a cup-shaped carrier section having a center post or arbor and a peripheral bearing rib which is journaled in a raceway in a cup-shaped rotary hook member, such carrier-section having a rim flange formed with a rotation-restraining notch which is loosely entered by a tongue on a stationary rotation-restraining member mounted on the bed of the machine. The bobbin is housed in a cylindrical bobbin-case which removably fits in the carrier-section and carries a bobbin-thread tension-spring and a manually releasable latch engaging the center-post of the carrier-section. Rotary hook and thread-case devices of the general type discussed above have long been known and used and, in the many years of their prominence in the sewing machine art, they have engaged the talented efforts of the best sewing machine inventors and improvers, which efforts have been lavishly expended in bringing these devices up to the high state of development and perfection of performance known at the present time. This process of development has been painfully slow, as the paths of approach to the perfect hook and thread-case were beset with serious difficulties too numerous to mention for, as often happens, the elimination of one difficulty usually introduced other difficulties to be contended with, so that forward steps in the art were often a matter of compromise or the balancing of one consideration against another, so as to get a superior all around performance with a minimum of disadvantageous conditions.

A rotary hook and thread-case device at this high state of perfection is exemplified in the Kessler Patent No. 2,085,699, of June 29, 1937. It is the cumulative result of the efforts of sewing machine inventors over a period of upwards of seventy-five years.

It has all this time been recognized that the chief drawback of the lock-stitch sewing machine is the necessity of providing a wound bobbin of under thread over which each loop of needle-thread, projected through the work by the needle, must be spread and passed by the loop-taker. The bobbin of under thread requires frequent replenishment, which necessitates the periodical

stoppage of the machine. It goes without saying that the larger the bobbin is, the less frequently it will require replenishment, so that it has been constantly before the experts in this art to make the bobbin as large as possible. Unfortunately, however, the enlargement of the bobbin has heretofore necessitated a consequent enlargement of the thread-case which carried it and this, in turn, necessitated enlargement of the rotary hook and its raceway in which the thread-case is journaled. Enlargement of the raceway diameter is found to greatly increase heating difficulties at the high operative speeds demanded of the modern lock-stitch machine. Moreover, enlargement of the thread-case results in enlargement of the size to which each needle-loop must be drawn out or expanded by the rotary hook in order to pass it about the thread-case. As the take-up device must pull up each expanded needle-loop after it is interlocked with the bobbin-thread to set the stitch, it follows that in the making of each stitch, a length of needle-thread approximately equal to the length of thread in the expanded needle-loop must reeve through the eye of the needle. This repeated reeving of the needle-thread through the eye of the needle is highly destructive as it tends to fray and weaken the thread. Hence, the larger the bobbin-case, the greater the destructive reeving action at any given point in the thread-supply to the needle.

The present invention, therefore, has for an object to improve the thread-case of the modern rotary hook lock-stitch sewing machine, exemplified in the Kessler Patent No. 2,085,699, by materially increasing its bobbin-thread capacity, without detracting in any manner from its many points of superiority over its predecessors or sacrificing any of its superior operative characteristics, so painstakingly arrived at by prior inventors in the sewing machine art.

With the above and other objects in view, as will hereinafter appear, the invention comprises the devices, combinations and arrangements of parts hereinafter set forth and illustrated in the accompanying drawings of a preferred embodiment of the invention, from which the several features of the invention and the advantages attained thereby will be readily understood by those skilled in the art.

Of the accompanying drawings, Fig. 1 is a front face elevation of a sewing machine rotary hook and thread-case embodying the invention. Fig. 2 is a right side elevation of the parts shown in Fig. 1 with the rotary hook beak turned to a point 270° past loop-taking position. Fig. 3 is a

section on the line 3—3, Fig. 1. Fig. 4 is a section of the thread-case only, on the line 4—4, Fig. 1. Fig. 5 is a front face view of the main cup-shaped section of the thread-case. Fig. 6 is a rear face view of the same. Figs. 7 and 8 are perspective views of the same. Fig. 9 is a face view of the rotary hook member in which the thread-case is journaled. Fig. 10 is a perspective view of the rotary hook member. Figs. 11 and 12 are respectively, front face and left edge views of the cap-section of the thread-case. Fig. 13 is a bottom edge view of the cap-section shown in Fig. 11. Fig. 14 is a perspective view of the cap-section of the thread-case. Fig. 15 is a perspective view of the cap-section of the thread-case together with a bobbin of thread. Fig. 16 is a horizontal diametrical section of the parts shown in Fig. 15. Fig. 17 is a disassembled perspective view of the latch-elements carried by the thread-case cap and Fig. 18 is a section through the thread-case substantially in the plane of the inner face of the thread-case cap or on the line 18—18, Fig. 4.

1 represents the reciprocatory needle of a sewing machine having the usual throat-plate 2 which is formed with the needle-hole 3 and feed-dog slots 4. Disposed below the throat-plate 2 is the conventional cup-shaped rotary hook body 5 having a bearing raceway 6 and cut away on one side to provide a loop-seizing beak 7 having an inclined loop-spreading edge 8. Fig. 10, crossing the plane of the raceway 6. The hook-body also includes the removable gib 9 the inwardly extending flange 10 of which constitutes the outer wall of a section of the raceway 6 in which the peripheral bearing rib 11 of the stationary thread-case is journaled. The gib 9 is pointed at one end to constitute a loop-controlling tail 12 onto which the cast needle thread-loop 13, Fig. 2, is drawn from the hook-beak 7 by the usual take-up device, not shown, to prevent the loop 13 from twisting and kinking and to hold it off of the thread-case bearing rib 11 as explained in the said Kessler Patent No. 2,085,699.

The stationary thread-case, Fig. 4, in which the present invention is embodied comprises the main section 14, Figs. 5, 6, 7 and 8, and the cap section 30, Figs. 11 to 16, inclusive. The main section 14 of the thread-case is of cylindrical cup shape and has at its rim the usual outwardly extending needle-loop guard-flange 16 which is preferably notched at 17 in accordance with the disclosure of the said Kessler Patent No. 2,085,699. The main section 14 of the thread-case carries the peripheral bearing rim 11 which has a gap in its upper portion to provide the usual needle-loop detaining shoulder 18 and needle-loop confining shoulder 19 the functions of which are well understood by those skilled in the art and need not be here dwelt upon. The flange 16 is also formed with the usual rotation-restraining notch 20 which is loosely entered by the tongue 21 on the usual rotation-restraining bar 22 common to rotary hook lock-stitch sewing machines.

The main section 14 of the thread-case has an inner cylindrical side wall 23 and an inner flat end wall 24 which supports the axial center post 25 grooved at 26 for a latch member to be referred to. The rim of the cup-shaped main section 14 of the thread-case is cut away at one side as far as the peripheral bearing rib 11 to form a gap 27 which has a special purpose in the present arrangement. The inner cylindrical wall 23 of the thread-case section 14 is counterbored or enlarged in diameter at 28 to receive the short thin

skirt portion 29 of the cap-section 30 which removably closes the outer end of the main section 14 of the thread-case and has a tubular arbor 31 which slidably fits the post 25 and freely receives the bobbin member 32. The counterbore 28 excludes a non-counterbored wall portion underlapping the bearing rib 11 which non-counterbored underlapping wall portion is of normal and adequate strength to carry the peripheral bearing rib and withstand, without distortion, the usual case-hardening operation to which thread-cases are customarily subjected.

The skirt of the cap-section 30 is lengthened at one side at 33 to fill the gap 27 in the main section 14 of the thread-case. Mounted on the lengthened skirt portion 33 is the tension leaf spring 34 the pressure of which upon the bobbin-thread 35 may be regulated by manipulation of the tension-regulating screw 36 in the usual manner. The shoulder 37 near the base end of the tension-spring 34 together with the shoulder formed by the free end 38 of the tension-spring 34 extend into the gap 27 in the cylindrical wall of the main thread-case section 14 and rotatively position the cap-section relative to the main section, as shown in Fig. 18. In other words, the cap-section can only be applied to the main section with the shoulders 37 and 38 juxtaposed with the shoulders at the ends of the gap 27. An important feature gained by the present improvement is this, that the radius of curvature of the inner wall of the cap skirt 33 is as great as that of the inner cylindrical wall 23 of the main section. Hence a bobbin can be accommodated which has flanges substantially as large in radius as the radius of curvature of the inner wall 23 of the main section of the thread-case; the skirt of the cap-section being no longer a limiting factor as to bobbin flange diameter. By these means I have increased the capacity of the bobbin of the thread-case of the Kessler Patent No. 2,085,699 at least 20% without increasing the overall size of the thread-case or increasing the diameter of the thread-case bearing rib and without sacrifice of any of the improved operative characteristics of the hook and bobbin-case device, as disclosed in said Kessler Patent No. 2,085,699.

The cap-section 30 is fitted with the usual manually operated latch-bar 39 which slides in a diametrical slideway 40 in the face of the cap-section 30 and is biased to latching position by the spring 41 which engages the lateral extension 42 of the latch-bar. The latch-bar has a hole 43 in it to admit the grooved end of the center post 25 of the main thread-case section, after which the bar is slid endwise by the spring 41 to carry the curved edge-portion of the bar at the hole 43 into the groove 26 of the center post 25. The latch-bar 39 pivotally carries the finger-piece or lever 44 which at its inner end may be caused to impinge upon the shoulder 45 at one side of a square hole 46 in the cap-section 30, which shoulder affords a fulcrum for the lever 44 to withdraw the latch-bar 39 from locking engagement with the grooved center post 25 for removal of the cap-section to gain access to the bobbin 32. The latch-bar has at one end the usual curved bobbin-flange-gripping extension 45 which enters the notch 46 in the flange 16 of the main thread-case section, after the cap-section has been applied to the main section and locks the cap-section against rotation relative to the main section independently of the initial positioning shoulders 37 and 38 previously described.

The longer skirt portion 33 of the cap-section, 75

which carries the thread-tension spring 34 is formed with the threading slot 47 leading to the thread exit hole 48, Fig. 14, under the free end of the tension-spring 34.

The bobbin 32 may be applied, as usual, to the tubular arbor 31 of the cap-section 30 and the two applied to the main thread-case section, as readily as heretofore.

The thread-case body is preferably chamfered adjacent its inner edge at 49, Figs. 4 and 6, to provide the needle-loop cast-on corner 50, as disclosed in the Kessler U. S. Patent No. 1,995,278, dated Mar. 19, 1935, to facilitate an early casting of the needle-loop onto the back face of the thread-case, as explained in said last mentioned Kessler patent.

The short skirt portion 29 of the thread-case cap-section guards one of the bobbin-flanges, as shown in Fig. 15, so that the cap-section with the bobbin may be held at its rim in the fingers of one hand while the operator draws the bobbin-thread 35 into the threading slot 47 and to final position in the hole 48 and out under the free end of the tension-spring 34, the bobbin 32 being free to turn on the arbor 31 during the manual threading operation. In other words, because of the protecting skirt 29, the parts shown in Fig. 15 may be readily held for the threading operation without interfering with the free rotation of the bobbin 32 on the arbor 31.

Having thus set forth the nature of the invention, what I claim herein is:

1. A thread-case for rotary hook lock-stitch sewing machines comprising a cup-shaped main section and a substantially circular cap-section, said cup-shaped main section having a peripheral bearing rib and a cylindrical inner side wall which is counterbored in the rim portion thereof, the counterbore portion of said main section excluding a non-counterbored portion underlapping said peripheral bearing rib, said cap-section having a circular disk-like head received in the counterbore in said main section, and manually operable means for releasably latching said sections together.

2. A thread-case for rotary hook lock-stitch sewing machines comprising a cup-shaped main section and a substantially circular cap-section, said cup-shaped main section having a peripheral bearing rib and a cylindrical inner side wall which is counterbored in the rim portion thereof, the counterbored portion of said main section excluding a non-counterbore portion underlapping said peripheral bearing rib, said cap section having a short skirt portion received in the counterbore in said main section, and manually releasable means for latching said sections together.

3. The combination with a cup-shaped rotary hook-body having a circular thread-case bearing and cut away at one side to form a loop-taking beak, of a cylindrical cup-shaped thread-case body having at its rim an outwardly extending needle-loop guard-flange, said thread-case body having an inner end wall, a cylindrical inner side wall and an axial post supported by said inner end wall, said thread-case body also having a peripheral bearing between said guard-flange and the inner end-face of such body, which bearing is complementary to the bearing in said hook-body, the rim of said thread-case being cut away at one side as far as said peripheral bearing, a thread-case-cap removably closing the outer end of said thread-case and having a tubular arbor slidably fitting said post, a releasable latch carried by said cap and engaging said post, said cap

having a segmental cylindrical skirt portion at one side bridging the cut-away portion of the rim of the thread-case body, and a tension leaf-spring mounted on the skirt portion of said cap, the internal radius of curvature of said cap-skirt portion being as large as that of the cylindrical thread-case to house a bobbin-thread mass of maximum size commensurate with a given diameter of hook-raceway bearing.

4. The combination with a cup-shaped rotary hook-body having a circular raceway and cut away at one side to form a loop-taking beak, of a cylindrical cup-shaped thread-case body having at its rim an outwardly extending needle-loop guard-flange, said thread-case body having an inner end wall, a cylindrical inner side wall and an axial post supported by said inner end wall, said thread-case body also having a peripheral bearing rib between said flange and the inner end-face of such body, which bearing rib is journaled in said hook raceway, the rim of said thread-case body being cut away at one side substantially as far as said bearing rib and being counterbored in the remaining rim portion which carries the needle-loop guard-flange, a thread-case-cap removably closing the outer end of said thread-case and having a tubular arbor slidably fitting said post, a releasable latch carried by said cap and engaging said post, said cap having a short skirt-portion received in the counterbore in the rim of said thread-case body, said skirt-portion being lengthened at one side to bridge the cut-away portion of the rim of the thread-case body, and a tension-spring mounted on the longer skirt-portion of said thread-case cap.

5. The combination with a rotary hook-body having a loop-taking beak, of a stationary thread-case journaled in said rotary hook-body and comprising a cup-shaped main section having an axial center post and a cylindrical inner side wall coaxial with said center post, a disklike cap-section closing the open end of the main section, a bobbin-thread tension-spring and a manually operable latch each carried by the cap-section, said latch engaging said center post, said cap-section having a tubular arbor slidably fitting said center post and a segmental cylindrical skirt-portion on which said tension-spring is mounted, said skirt-portion having an inner radius of curvature as great as that of the inner cylindrical wall of the main section of the thread-case, the rim of said main section being cut away at one side to receive said segmental skirt-portion and tension-spring which serve to rotatively locate the cap-section upon the main section of the thread-case.

6. A thread-case, for use in the cup-shaped rotary hook of a sewing machine, comprising a main cup-shaped section having at its rim an outwardly extending needle-loop guard-flange, said main section also having an inner end wall, an inner cylindrical side wall and an axial post supported by said inner end wall, said main section also having a peripheral bearing between said flange and end wall, which bearing is complementary to the thread-case bearing in the rotary hook with which it is to be used, the rim of said main section being cut away at one side substantially as far as said bearing and being counterbored in the remaining rim portion which carries said guard-flange, a thread-case cap-section removably closing the open outer end of said main section and having a tubular arbor slidably

fitting said post, a releasable latch carried by said cap-section and engaging said post, said cap-section having a short skirt-portion received in the counterbore in said main section, said skirt-portion being lengthened at one side to bridge the cut-away portion in the rim of the main section, and a tension-spring mounted on the longer skirt portion of said thread-case cap.

7. A stationary thread-case for rotary hook sewing machines comprising separable main and cap-sections, said main section being cup-shaped and having at its rim an outwardly extending needle-loop guard-flange which is formed at its upper portion with rotation-restraining means, said main section also having a cylindrical inner side wall and a flat inner end wall, a center post carried by said end wall and having a latching groove at its free end, said main section also having a peripheral bearing rib disposed between the plane of said end wall and said needle-loop

guard-flange, a rim-portion of the side wall of said main section being cut away as far as said peripheral bearing rib and the remaining rim-portion being counterbored to an axial depth not exceeding the spacing of the peripheral bearing rib from the needle-loop guard-flange, said cap-section having a substantially circular head received in the counterbore in said main section, said cap-section head having a cylindrical skirt-portion at its edge which substantially closes the gap in the rim of said main section, a tension leaf-spring mounted on the outer side wall of said skirt-portion in said gap with the free end of said tension-spring terminating in said gap in non-underlapping relation with the rim of said main section, and a manually operable latch mounted on said cap-section and engageable with the latching groove in said center post.

JOHN D. KARLE. 20