

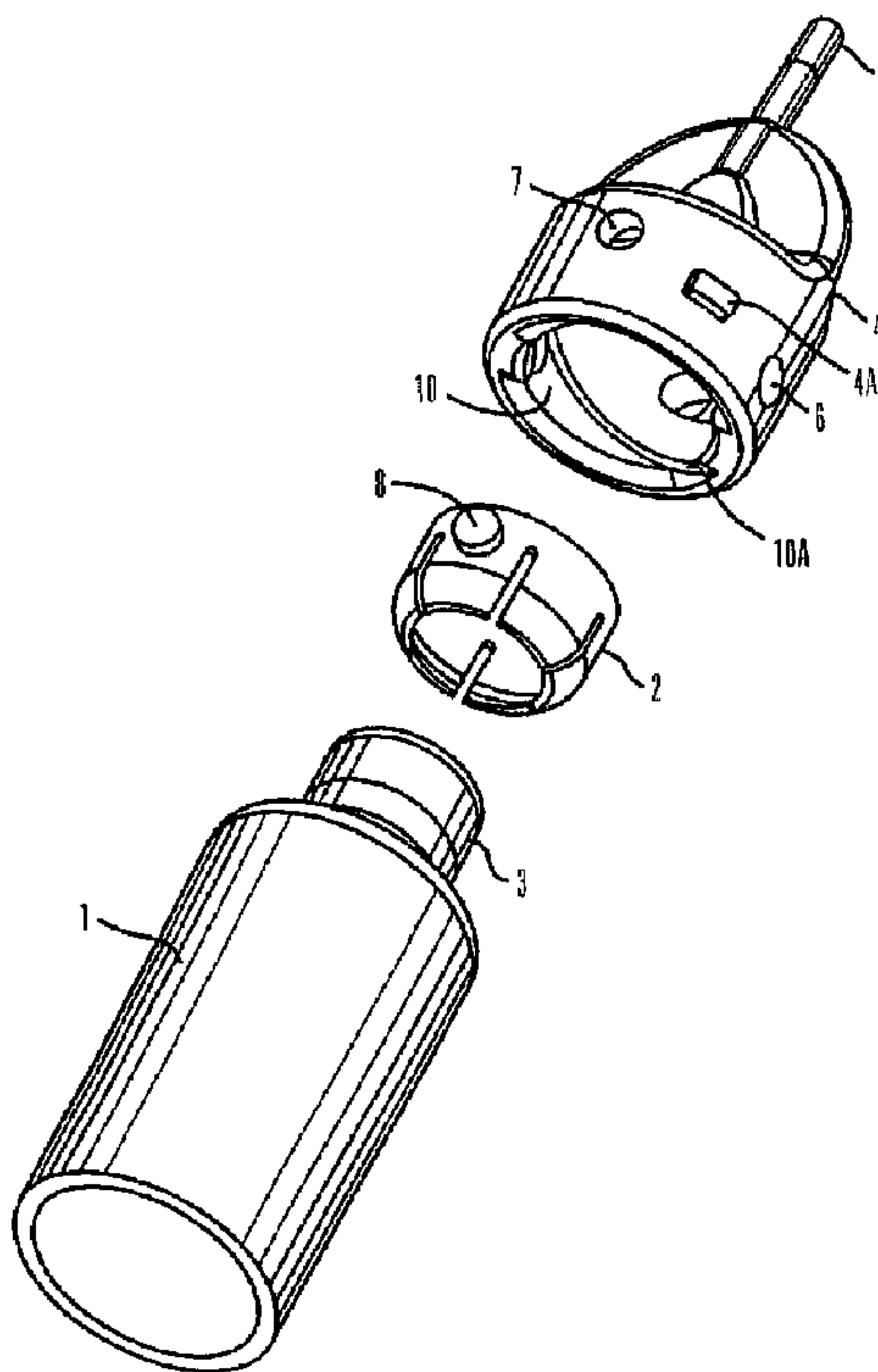

(22) Date de dépôt/Filing Date: 1999/10/28  
 (41) Mise à la disp. pub./Open to Public Insp.: 2000/05/11  
 (45) Date de délivrance/Issue Date: 2014/01/28  
 (62) Demande originale/Original Application: 2 533 850  
 (30) Priorité/Priority: 1998/10/29 (US60/106,237)

(51) Cl.Int./Int.Cl. *A61M 5/145* (2006.01),  
*A61J 1/20* (2006.01), *A61M 5/162* (2006.01)  
 (72) Inventeurs/Inventors:  
ADAIR, RANDY W., US;  
MOBERG, SHELDON, US;  
SRISATHAPAT, CHALIRMKIERT, US  
 (73) Propriétaire/Owner:  
MEDTRONIC MINIMED, INC., US  
 (74) Agent: OYEN WIGGS GREEN & MUTALA LLP

(54) Titre : RACCORD POUR RESERVOIR  
 (54) Title: RESERVOIR CONNECTOR



(57) **Abrégé/Abstract:**

A method and apparatus for a connection interface between a reservoir or syringe, infusion set tubing, and an infusion pump is provided. A base is provided which is adapted to receive a reservoir. The base has a base engagement member, such as a detent, projecting therefrom. A cap is provided which is adapted to receive the base. The cap includes a first cap engagement member, such as a detent opening, which is adapted to removably engage the base detent. The cap further includes a second cap detent opening which is adapted to removably engage the base detent. A piercing member, such as a needle, is disposed in the interior of the cap in such a manner that the needle is separated from the reservoir septum when the base detent is in the first cap detent opening, and the needle pierces the reservoir septum when the base detent is in the second cap detent opening. When the reservoir, the base and the cap are connected to form an integrated unit, this unit is then capable of being inserted and secured in the infusion pump housing.



5

ABSTRACT

A method and apparatus for a connection interface between a reservoir or syringe, infusion set tubing, and an infusion pump is provided. A base is provided which is adapted to receive a reservoir. The base has a base engagement member, such as a detent, projecting therefrom. A cap is provided which is adapted to receive the base. The cap includes a first cap engagement member, such as a detent opening, which is adapted to removably engage the base detent. The cap further includes a second cap detent opening which is adapted to removably engage the base detent. A piercing member, such as a needle, is disposed in the interior of the cap in such a manner that the needle is separated from the reservoir septum when the base detent is in the first cap detent opening, and the needle pierces the reservoir septum when the base detent is in the second cap detent opening. When the reservoir, the base and the cap are connected to form an integrated unit, this unit is then capable of being inserted and secured in the infusion pump housing.

5

## RESERVOIR CONNECTOR

10

BACKGROUND OF THE INVENTION1. Field of the Invention

15 This invention relates generally to improvements in syringe and reservoir interfaces for use in infusion pumps such as those used for controlled delivery of medication to a patient. More specifically, this invention relates to an improved connection interface between a reservoir or syringe, infusion set tubing, and an infusion pump.

2. Description of the Related Art

20 Infusion pump devices and systems are relatively well-known in the medical arts, for use in delivering or dispensing a prescribed medication such as insulin to a patient. In one form, such devices comprise a relatively compact pump housing adapted to receive a syringe or reservoir carrying a prescribed medication for administration to the patient through infusion tubing and an associated catheter.

25 The infusion pump includes a small drive motor connected via a lead screw assembly for motor-driven advancement of a reservoir piston to administer the medication to the user. Programmable controls are normally provided for operating the drive motor continuously or at periodic intervals to obtain a closely controlled and accurate delivery of the medication over an extended period of time. Such infusion pumps are utilized to  
30 administer insulin and other medications, with exemplary pump constructions being shown and described in U.S. Patent Nos. 4,562,751; 4,678,408; 4,685,903; 5,080,653 and 5,097,122.

35 Infusion pumps of the general type described above have provided significant advantages and benefits with respect to accurate delivery of medication or other fluids over an extended period of time. The infusion pump can be designed to be relatively compact as well as water resistant, and may thus be adapted to be carried by the user, for example, by means of a belt clip. As a result, important medication can be delivered to the user with

5 precision and in an automated manner, without significant restriction on the user's mobility or life-style, including the ability to participate in water sports.

10 Infusion sets refer to the tubing and connection apparatus which provide a path for the medication to flow from the reservoir or syringe located in the pump to the user. The connectors for attaching the infusion set tubing to the reservoirs can take various forms. A luer connection is a commonly used connection method. Nevertheless, it remains desirable to develop improved designs of connection methods to facilitate infusion procedures and to provide suitable interface connections which are water resistant so as to permit a user to participate in water sports.

15 SUMMARY OF THE PREFERRED EMBODIMENTS

20 An apparatus for connecting a reservoir having a septum and a base to a conduit, such as infusion set tubing, is provided. In certain aspects of the present invention, the apparatus comprises a cap and a releasable coupler which is adapted to releasably couple the base to the cap in one of two positions. A piercing member, such as a needle, is coupled to the conduit. The needle is disposed in the cap in a position other than the interior of the reservoir when the base is in the first position. The needle is further disposed to pierce the reservoir septum when the base is in the second position.

25 In another embodiment, the apparatus is used for connecting a reservoir having a septum and a base to a housing as well as to a conduit. The housing has a housing engagement member, such as a thread. The apparatus comprises a cap and a releasable coupler which is adapted to releasably couple the base to the cap in one of two positions. A piercing member, such as a needle, is releasably coupled to the conduit. The needle is disposed in the cap in a position other than the interior of the reservoir when the base is in  
30 the first position. The needle is further disposed to pierce the reservoir septum when the base is in the second position. The cap further includes an engagement member, such as a thread, which is adapted to engage with the housing engagement member.

35 In another embodiment, the cap further includes a vent port which is covered with hydrophobic material. This permits air to pass through the cap while preventing water from doing so.

5

BRIEF DESCRIPTION OF THE DRAWINGS

FIG. 1 is an exploded, perspective view of a medication reservoir connection interface apparatus.

FIG. 2 is a perspective view of a cap used as a medication reservoir connection interface apparatus.

10

FIG. 3 is an exploded, perspective view of an alternative embodiment of a medication reservoir connection interface apparatus.

FIG. 4 is a side, cut-away view of a cap used as a medication reservoir connection interface apparatus.

15

FIG. 5 is a side, plan cut-away view of a medication reservoir connection interface apparatus with a needle inserted into a reservoir.

FIG. 6 is a side, plan cut-away view of a medication reservoir connection interface apparatus which is inserted into a pump housing.

FIG. 7 is a perspective view of an alternative embodiment of a medication reservoir connection interface apparatus.

20

FIG. 8 is a perspective top view of an alternative embodiment of a medication reservoir connection interface apparatus which is secured into a pump housing.

FIG. 9 is a perspective view of an alternative embodiment of a medication reservoir connection interface apparatus.

25

FIG. 10 is an exploded, perspective view of a cap used as a medication reservoir connection interface apparatus.

FIG. 11 is a perspective view of a medication reservoir connection interface adapter.

FIG. 12 is a cross-sectional view of a medication reservoir connection interface adapter.

30

FIG. 13 is a perspective view of an alternative embodiment of a cap used as a medication reservoir connection interface apparatus.

FIGs. 14a - 14c are cross-sectional views of various embodiments of venting ports for use with a reservoir connection interface apparatus or adapter.

5                    DETAILED DESCRIPTION OF THE PREFERRED EMBODIMENTS

In the following description, reference is made to the accompanying drawings which form a part hereof and which illustrate several embodiments of the present invention. It is understood that other embodiments may be utilized and structural and operational changes may be made without departing from the scope of the present invention.

As shown in the drawings for purposes of illustration, the invention is embodied in an interface for connecting a syringe or a medication reservoir to a conduit, such as infusion set tubing or an external needle, as well as to an infusion pump. In a one embodiment, a base is provided which is adapted to receive a reservoir. A cap is provided which is adapted to be releasably coupled to the base in one of two positions. The releasable coupler comprises a pair of detents projecting from the base and two pairs of detent openings in the cap which are adapted to removably engage the base detents.

A piercing member, such as a needle, is disposed in the interior of the cap in such a manner that the needle is separated from the reservoir septum when the base detents are in the first pair of cap detent openings, and the needle pierces the reservoir septum when the base detents are in the second pair of cap detent openings. When the reservoir, the base and the cap are connected, an integrated unit is formed which is then capable of being inserted in the infusion pump housing. Engagement members, such as threads, for the cap and the pump housing are used to secure the integrated unit in the housing.

FIGS. 1 and 2 show an infusion set connector interface for attachment to a medication reservoir. The connector interface is comprised of a base 2 and a cap 4. The cap 4 includes a needle 9 located internal to the cap housing. FIG. 1 is an exploded view, and therefore, the base 2 would normally be fixedly attached to a reservoir 1 by securing it around the swage 3. However, alternative embodiments of the present invention include a removable base so that the connector interface could be used with standard reservoirs, cartridges or syringes which were not initially manufactured with the base attached.

The cap 4 portion of the connector interface is removably attached to the base 2 with a releasable coupler. In one embodiment, the releasable coupler is comprised of detents formed on the base 2 and detent openings disposed in the cap 4. Two detents 8 are disposed on the sides of the base 2 and are spaced 180° radially apart. Only one detent 8 is shown in FIG. 1. The detents 8 are sized to fit in the two lower detent openings 6, or

5 alternatively, in the two upper detent openings 7 which are formed in the cap 4. As with the pair of detents 8, each of the lower detent openings 6 and each of the upper detent openings 7, respectively, are radially spaced apart by 180 °.

In operation, the base 2 and the reservoir 1 form an integrated unit which in turn is to be connected to the cap 4. In connecting this integrated base/reservoir unit to the cap 4,  
10 the base 2 is inserted into the lower end of the cap 4 until the detents 8 snap into the lower detent openings 6. This is accomplished by moving the detents 8 over internal cam surfaces 10 toward the lower detent openings 6. The cam surfaces act as ramps which compress the detents 8 sufficiently to permit them to snap into the lower detent openings 6. Internal threads 10a guide the detents 8 into position.

15 When the base/reservoir unit is in this first, lower position, the needle 9 is positioned apart from the septum (not shown) of the reservoir 1. Thus the needle does not pierce the septum while the base/reservoir unit is in this first position. When the base/reservoir unit is connected to the cap in this fashion, an integrated cap/base/reservoir unit is thereby formed. Such an integrated cap/base/reservoir unit can be sold or stored for  
20 long periods of time in this fashion. Alternatively the end user could assemble this unit shortly prior to placing it in the pump for use.

When the user desires to insert the cap/base/reservoir unit in the pump housing and commence dispensing the medication through a conduit, such as insertion set tubing 5, the base 2 is moved to the second position within the cap 4. This is accomplished by twisting  
25 the base /reservoir unit while pushing it further into the cap 4. The detents 8 disengage from the lower detent openings 6 and engage into the upper detent openings 7. Additional internal threads 10a of the cap 4 serve to guide the detents 8 over additional cam surfaces 10 from their first position in the lower detent openings 6 to the second position in the upper detent openings 7.

30 In one embodiment, the threads and the spacing between the lower detents 6 and the upper detents 7 is such that a one quarter (1/4) turn of the base will cause the base/reservoir unit to travel from the first to the second position. The needle 9 is disposed so that when the base/reservoir unit is in the second position, the needle pierces the septum of the reservoir 1. Thus the movement of the base/reservoir unit from the first to the  
35 second position within the cap serves to cause the needle to pierce the reservoir's septum, thus permitting the fluid in the reservoir to flow into the needle 9 and the insertion set tubing 5.

5 After this connection is made, the reservoir, base and cap form a unit which can be  
releasably secured in the housing of a medication infusion pump. (not shown) Detents 4a  
extend radially from the exterior of the cap and are adapted to engage into detent openings  
(not shown) in the pump housing. In an alternative embodiment, the cap 4 can include  
external threads (not shown) which are used to engage the threads of the pump housing in  
10 order to secure the reservoir/base/cap unit into the housing.

FIGs. 3 and 4 show an alternative embodiment of the infusion set connector  
interface. The connector interface is comprised of a base 11 and a cap 12. The cap 12  
includes a needle 18 located internal to the cap housing (FIG. 4). The base 11 would  
normally be fixedly attached to the reservoir 1 by securing it around the swage 3.  
15 However, alternative embodiments of the present invention include a removable base so  
that the connector interface could be used with standard reservoirs, cartridges or syringes  
which were not initially manufactured with the base attached.

The cap 12 portion of the connector interface is removably attached to the base 11  
with a releasable coupler. In this embodiment, the releasable coupler is comprised of  
20 detents formed on the base 11 and detent openings disposed in the cap 12. Two detents 13  
are disposed on the sides of the base 11 and are spaced 180 ° radially apart. Only one  
detent 13 is shown in FIG. 3. The detents 13 are sized to fit in two detent openings 14  
which are formed in the cap 12. As with the pair of detents 13, each of the detent openings  
14 are radially spaced apart by 180 °.

25 In operation, the base 11 and the reservoir 1 form an integrated unit which in turn  
is to be connected to the cap 12. In connecting this integrated base/reservoir unit to the  
cap 12, the base 11 is inserted into the lower end of the cap 12. The detents 13 slide into  
matingly shaped and longitudinally open entry slots 15 formed within the interior walls of  
the cap 12. When the base 11 is fully inserted in the cap 12, the leading edges of the  
30 detents 13 abut an annular stop shoulder 16 formed within the cap 12. After the detents 13  
are in this position, the base 11 is rotated within the cap 12 toward a locked position.  
Referring to FIG. 4, this rotation displaces the detents 13 in a rotational direction for  
engagement with cam surfaces 17 formed within the cap 12. The rotational force on the  
detents 13 over the cam surfaces 17 provides a compression force on the detents 13.  
35 Continued rotation of the base 11 displaces the detents 13 past the cam surfaces 17 and  
into alignment with the detent openings 14. The detents 13 enter the detent openings 14  
with a snap-action. Thus, the detents 13 are effectively locked within the detent openings



5 14 to prevent longitudinal separation of the base 11 from the cap 12.

In the preferred embodiment, the internal needle 18 of the cap 12 is disposed so that when the base/reservoir unit is fully inserted in the cap 12, the needle pierces the septum (not shown) of the reservoir 1. Thus the insertion force of the base/reservoir unit to the point where the detents 13 abut the annular stop shoulder 16 causes the needle 18 to  
10 pierce the septum, thus permitting the fluid in the reservoir to flow into the needle 18 and the insertion set tubing (not shown).

After this connection is made, the reservoir, base and cap form a unit which can be releasably secured in the housing of a medication infusion pump. (not shown) The cap 12 includes external threads 19 which are used to engage the threads of the pump housing in  
15 order to secure the reservoir/base/cap unit into the housing. In the preferred embodiment, the threads 19 have an eight threads per inch ("TPI"), 2 start profile. Moreover, they have a square shaped cross section which maximizes their holding strength. Other thread profiles and cross-sections may be used however.

When disconnection of the base 11 from the cap 12 is desired, the base 11 must be  
20 reverse-rotated within the cap 12, to move the detents 13 past the cam surfaces 17 into re-alignment with the entry slots 15. Such reverse-rotation of the coupler can be performed relatively easily, but essentially requires an affirmative intent by the user to disconnect the coupling. When the detents 13 are re-aligned with the entry slots 15, the cap 12 and base 11 can be separated easily with minimal longitudinal force.

25 FIG. 5 shows a cross sectional view of the reservoir/base/cap integrated unit in accordance with the embodiment of FIGs. 3 and 4. The reservoir 1 includes a crimp seal swage 3 which encloses the outer periphery of the rubber septum 20 in order to secure the septum 20 to the reservoir 1 and form a water tight seal. With the base 11 in the locked position as shown, the detents 13 of the base 11 are locked into the detent openings 14 to  
30 securely attach the base/reservoir unit into the cap 12. The needle 18 pierces the rubber septum 20, thus permitting the flow of liquid through the needle 18 and into the infusion set tubing cavity 22. Infusion set tubing (not shown) is secured into the cavity 22 to allow the liquid to continue its flow to the user.

In the preferred embodiment, the conduit from the cap 12 is infusion set tubing.  
35 However in an alternative embodiment, the conduit comprises a second needle (not shown). This is secured into the cavity 22 with the point of the second needle extending outward. With this arrangement, the connector serves as an apparatus for permitting the

5 refilling of the reservoir 1. The second, external needle would pierce the septum of a supply vial of fluid. The fluid could then be drawn into the cap in a reverse flow and into the reservoir 1 via the internal needle 18.

In the embodiment shown in FIG. 5, infusion set tubing is secured to the cavity 22 to allow liquid to flow to the user. The cavity 22 is disposed in the raised portion of the cap 12. In an alternative embodiment, however, the raised portion of the cap 12 can be in  
10 the shape of a standard luer fitting 47 shown in FIG. 13.

Referring to FIG. 5, in one embodiment the base 11 is formed around and fixedly attached to the crimp seal swage 3 portion of the reservoir 1. In an alternative embodiment, however, the base 11 is not fixedly attached to the reservoir. Rather, the  
15 base 11 is a separate unit which is adapted to be releasably secured to the reservoir via a friction fit. This arrangement permits the connector apparatus to be used with standard reservoirs.

Still referring to FIG. 5, the cap 12 includes threads 19 for securing the assembly into the pump housing (not shown). A shoulder 23 is formed as part of the cap 12 and is  
20 adapted to seat against the pump housing to form a water tight seal. This prevents any water which is exterior to the housing from entering, thus permitting the user to engage in water sports.

The construction of these pumps to be water resistant can give rise to operational problems. As the user engages in activities which expose the pump to varying  
25 atmospheric pressures, such as for example, swimming or traveling in an air plane, differential pressures can arise between the interior of the air tight/water-resistant housing and the atmosphere. Should the pressure in the housing exceed external atmospheric pressure, the resulting forces could cause the reservoir piston to be driven inward thus delivering unwanted medication. Alternatively, should the pressure in the housing be less  
30 than the external pressure, the resulting forces could cause the infusion pump motor to work harder to advance the reservoir piston.

To address this problem, a preferred embodiment of the invention includes a vent which permits water resistant housing construction. The cap 12 includes a plurality of vent ports 24, only one of which is shown in FIG. 5. The vent ports 24 permit  
35 equalization of pump housing pressure to atmospheric pressure. Hydrophobic material (not shown) covers the interior openings of the vent ports 24. Hydrophobic material permits air to pass through the material while preventing water or other liquids from doing

5 so, thus permitting water resistant venting. The preferred embodiment uses a hydrophobic material such as Gore-Tex® , PTFE, HDPE, or UHMW polymers from sources such as W.I. Gore & Associates, Flagstaff, AZ, Porex Technologies, Fairburn, GA, DeWAL Industries, Saunderstown, RI, or Pall Specialty Materials, Port Washington, N.Y.

10 These materials are available in sheet form or molded (press and sintered) in a geometry of choice. Referring to FIGs 14a - 14c, preferred methods to attach this material to the cap 12 include molding the hydrophobic material into a sphere 50 (FIG. 14a) or a cylinder 51 (FIG. 14b) and pressing it into a cavity in the pre-molded plastic housing. Alternatively, a label 52 (FIG. 14c) of this material could be made with either a transfer adhesive or heat bond material 53 so that the label could be applied over the vent port 24.

15 Alternatively, the label could be sonically welded to the housing. In either method, air will be able to pass freely, but water will not.

In an alternative embodiment which is not shown, the venting is accomplished through a vent port located in the pump housing.

20

Alternatively, vent ports can be placed both in the cap 12 as well as the pump housing.

An advantage of placing the vent port and hydrophobic material in the cap 12, as opposed to in the pump housing only, is that the infusion set and its related connectors are disposable and are replaced frequently with each new reservoir or vial of medication.

25 Thus, new hydrophobic material is frequently placed into service. This provides enhanced ventilation as compared with the placement of hydrophobic material in only the pump housing. Material in this location will not be replaced as often and thus is subject to dirt or oil build up which will retard ventilation.

As an alternative to the use of hydrophobic material, water can be prevented from

30 flowing through the vent port by other apparatuses, such as the use of relief valves.

FIG. 6 shows a cross-sectional view of the reservoir/base/cap unit in accordance with the embodiment of FIGs. 3 and 4 which is secured into a pump housing 30. The threads 19 of the cap 12 engage the pump housing threads. Rather than the use of threads, an alternative embodiment (not shown) of the cap 12 could include detents extending

35 radially from the exterior of the cap 12 which are adapted to engage detent openings in the pump housing.

The shoulder 23 portion of the cap 12 seats against the pump housing 30 to permit

5 water tight construction. Further aiding in the water tight construction is an O-ring seal 31 which is disposed in the pump housing 30 and located just above the shoulder 23. In the preferred embodiment, the vent material 32 is comprised of hydrophobic material and is sonic welded to the upper interior surface of the cap 12. Alternatively, the vent material 32 could be attached to the cap 12 with an adhesive. The vent ports are not shown in FIG.  
10 6.

Although the foregoing description of the venting was in connection with the embodiment of FIGs 3 - 6, this feature is also applicable to the embodiment of FIGs 1 - 2.

FIGs. 7 and 8 show an alternative embodiment of the cap 12. Referring to FIG. 7, a cap engagement member consists of a detent arm 34 which is formed in the upper  
15 portion of the cap 12. The purpose of the detent arm 34 is to securely engage the cap 12 into the pump housing. FIG. 8 shows a top view of the cap 12 positioned in the pump housing 30. The pump housing 30 has two case lock recesses 35 disposed in the circular rim of the housing. The detent arm 34 snaps into either of the case lock recesses 35. This engagement results in a "click" when the cap 12 is appropriately seated, thus providing  
20 both tactile and audible feedback to the user that the cap is securely engaged in the pump housing. Moreover, the detent arm 34 aligning with the recess 35 also serves as a visual indicator that the cap 12 is appropriately seated.

FIG. 9 shows an alternative embodiment of the cap 12 which contains a child safety feature. The cap 12 includes a locking member which consists of a safety tab 36  
25 disposed in a groove 37. The safety tab 36 is sized such that it is able to slide along the length of the groove 37. When the safety tab 36 is in the position shown in FIG. 9, the detent arm 34 is unable to retract from its engaged position. Thus when the cap 12 is seated into the pump housing 30 (not shown) and the detent arm is seated into the case lock recess 35 (not shown), the safety tab 36 will prevent the detent arm 34 from  
30 disengaging from the case lock recess 35 thus more securely locking the cap 12 in the pump housing.

Thus for example, a parent could slide the safety tab 36 from the unlocked location in the groove 37 to the locked location shown in FIG. 9 so that it would be more difficult for a young child or infant to inadvertently remove the cap/base/reservoir unit from the  
35 pump housing. On the other hand, when the safety tab 36 is moved to the opposite end of the groove 37, the detent arm 34 is able to retract thus permitting removal of the cap 12 from the pump housing.

5           Although the foregoing description of the cap engagement member and child safety tab was in connection with the embodiment of FIGs 3 - 9, this feature is also applicable to the embodiment of FIGs 1 - 2.

10           FIG. 10 shows an exploded view of the cap 12 and the vent material 32. In the preferred embodiment, the vent material is made of hydrophobic material and is formed in a circular shape with a circular hole in the center. The vent material 32 is attached to the upper interior surface 38 of the cap 12 via sonic welding or an adhesive. When it is so attached, the needle 18 protrudes through the center hole of the vent material 32 but the interior openings of the vent ports 24 (not shown) are covered.

15           FIGs. 11 and 12 show an embodiment of the present invention where an adapter 40 is provided to allow a standard style syringe 41 with an integrated luer fitting 42 to be mounted and sealed in the pump housing. The syringe 41 is inserted through the center of the adapter 40 and held into place by a friction fit. The O-ring seal 43 in the adapter 40 seats against the syringe wall in order to prevent water and dirt from entering the pump housing.

20           A shoulder 45 is formed as part of the adapter 40 and is adapted to seat against the interior of the pump housing to form a water tight seal. Two tabs 44 are formed on the top surface of the adapter 40 and provide a surface for the user to grip the adapter 40 and twist it so that the adapter threads 19 engage the threads (not shown) of the pump housing. A detent arm 34 is formed in the upper portion of the adapter 40. Its purpose is to securely lock the adapter 40 into the pump housing (not shown) in the same manner as is shown in FIG. 8. Although not shown in FIGs. 11 and 12, the adapter 40 can further contain vent ports covered with hydrophobic material or a relief valve in order to permit water resistant venting of the pump housing in the same manner as previously described with other embodiments.

30           FIG. 13 shows another embodiment of the present invention where an interface is provided to connect a reservoir to a conduit, such as tubing, via a standard luer fitting connection. This allows a luer style disposable infusion set to connect to the pump housing (not shown). A cap 46 is formed with a luer fitting 47 portion as an integral part thereof. Except for the shape of the luer fitting 47 portion, the cap 46 has all of the other features of the cap 12 shown in FIG. 5. Thus referring to FIG. 13, the cap 46 is comprised of, among other things, threads 19, detent openings 14, a shoulder 23, vent ports 24, a detent arm 34, and a needle (not shown) disposed in the interior of the cap 46.

35

5           While the description above refers to particular embodiments of the present  
invention, it will be understood that many modifications may be made without departing  
from the spirit thereof. The accompanying claims are intended to cover such  
modifications as would fall within the true scope and spirit of the present invention. The  
presently disclosed embodiments are therefore to be considered in all respects as  
10 illustrative and not restrictive, the scope of the invention being indicated by the appended  
claims rather than the foregoing description, and all changes which come within the  
meaning and range of equivalency of the claims are therefore intended to be embraced  
therein.

## WHAT IS CLAIMED IS:

1. An apparatus for connecting a removable fluid medication reservoir to a fluid conduit and venting an infusion device; the apparatus comprising:
  - 5 a cap for coupling a fluid medication reservoir to a fluid conduit;
  - a housing engagement member comprising a detent or a thread projecting outward from a cylindrical external surface of the cap and adapted to engage an engagement member disposed in a housing recess within the infusion device, wherein the cap connects with the fluid medication reservoir and both the cap and the fluid medication reservoir at least partially fit inside the housing recess of the infusion device and are insertable and removable from the housing recess within the infusion device upon rotation of the cap;
  - 10 a conduit cavity disposed in the cap and adapted to secure the fluid conduit to the cap;
  - 15 a first tab disposed on the cap so as to provide a first surface for a user to grip and twist the cap to engage the cap with the infusion device upon rotation of the cap, wherein the first tab projects outward from the cap such that the first surface of the first tab is disposed in an orientation perpendicular to a plane defined by the circumference of the cap; and
  - 20 a vent disposed in the cap that permits the passage of air and simultaneously inhibits the passage of fluids so as to permit fluid resistant venting of air through the vent and equalization of pressure inside the infusion device to atmospheric pressure outside the infusion device.
- 25 2. The apparatus of claim 1, further comprising a piercing member disposed in the cap.
- 30 3. The apparatus of claim 2, wherein the piercing member creates a hole in a septum coupled to the reservoir when the reservoir is coupled and operatively engaged with the cap.
- 35 4. The apparatus of claim 1, wherein the cap further comprises a cap engagement member adapted to engage a housing engagement member of a housing and a shoulder to form a seal with the housing when the cap is engaged with the housing.

5. An infusion device for connecting a removable fluid medication reservoir to a fluid conduit, the infusion device comprising:
- a cap that is coupleable to the fluid conduit and having a vent disposed therein that permits the passage of air and simultaneously inhibits the passage of fluids so as to permit fluid resistant venting of air through the vent and equalization of pressure inside the infusion device to atmospheric pressure outside the infusion device;
  - a housing engagement member comprising a detent or a thread projecting outward from a cylindrical external surface of the cap and adapted to engage an engagement member disposed in a housing recess within an infusion device, wherein the cap connects with the fluid medication reservoir and both the cap and the fluid medication reservoir at least partially fit inside the housing recess of the infusion device and are insertable and removable from the housing recess within the infusion device upon rotation of the cap;
  - a first tab disposed on the cap so as to provide a first surface for a user to grip and twist the cap to engage the cap with the infusion device upon rotation of the cap, wherein the first tab projects outward from the cap such that the first surface of the first tab is disposed in an orientation perpendicular to a plane defined by the circumference of the cap; and means for removably coupling the reservoir with the cap; wherein the fluid conduit can transport a fluid from the reservoir through the fluid conduit when the reservoir is releasably coupled and operatively engaged with the cap.
6. An apparatus for connecting a removable fluid medication reservoir to a fluid medication conduit of an infusion device comprising:
- a cap for coupling the fluid medication reservoir to the fluid medication conduit;
  - a vent disposed in the cap that permits the passage of air and simultaneously inhibits the passage of fluids so as to permit fluid resistant venting of air through the vent and equalization of pressure inside the infusion device to atmospheric pressure outside the infusion device; a coupling member disposed in the cap for coupling the fluid medication conduit with the cap;
  - a housing engagement member comprising a detent or a thread projecting outward from a cylindrical external surface of the cap and adapted to



- engage an engagement member disposed in a housing recess within the infusion device, wherein the cap connects with the fluid medication reservoir and both the cap and the fluid medication reservoir at least partially fit inside the housing recess of the infusion device and are insertable and removable from the housing recess within the infusion device upon rotation of the cap;
- 5 a first tab disposed on the cap so as to provide a first surface for a user to grip and twist the cap to engage the cap with the infusion device upon rotation of the cap, wherein the first tab projects outward from the cap such that the first surface of the first tab is disposed in an orientation perpendicular to a plane defined by the circumference of the cap; and
- 10 a shoulder to permit water tight construction when the cap is engaged with the infusion device.
- 15 7. The apparatus of claim 6, wherein the fluid conduit comprises a needle.
8. The apparatus of claim 6, further comprising an O-ring seal.
9. The apparatus of claim 1, wherein the vent comprises a hydrophobic material that permits the passage air and simultaneously inhibits the passage of fluids.
- 20 10. The apparatus of claim 1, further comprising a shoulder disposed on the cap to sealingly engage the infusion device.
- 25 11. The apparatus of claim 1, further comprising a second tab disposed on the cap so as to provide a second surface for the user to grip and twist the connector to engage the cap with the infusion device upon rotation of the cap, wherein the second tab projects outward from the cap such that the second surface of the second tab is disposed in an orientation perpendicular to the plane defined by the circumference of the cap.
- 30 12. The apparatus of claim 11, wherein the first and second tabs are disposed on the cap in a diametrically opposed orientation.
- 35 13. The apparatus of claim 2, wherein the piercing member is disposed in an axis around which the cap rotates to create a hole in a septum coupled to the fluid

medication reservoir when the fluid medication reservoir is coupled and operatively engaged with the cap.

1/14

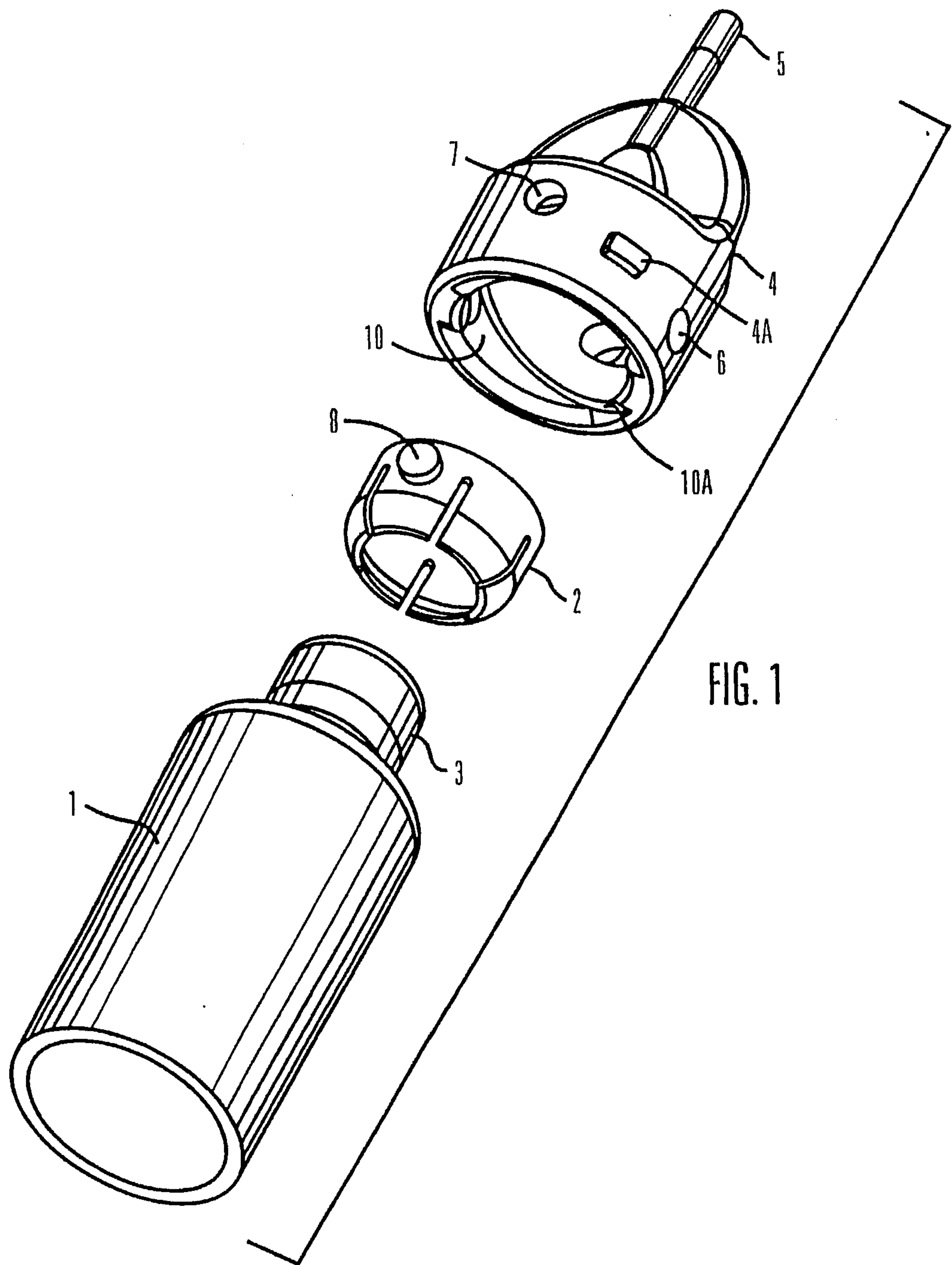

FIG. 1

2/14

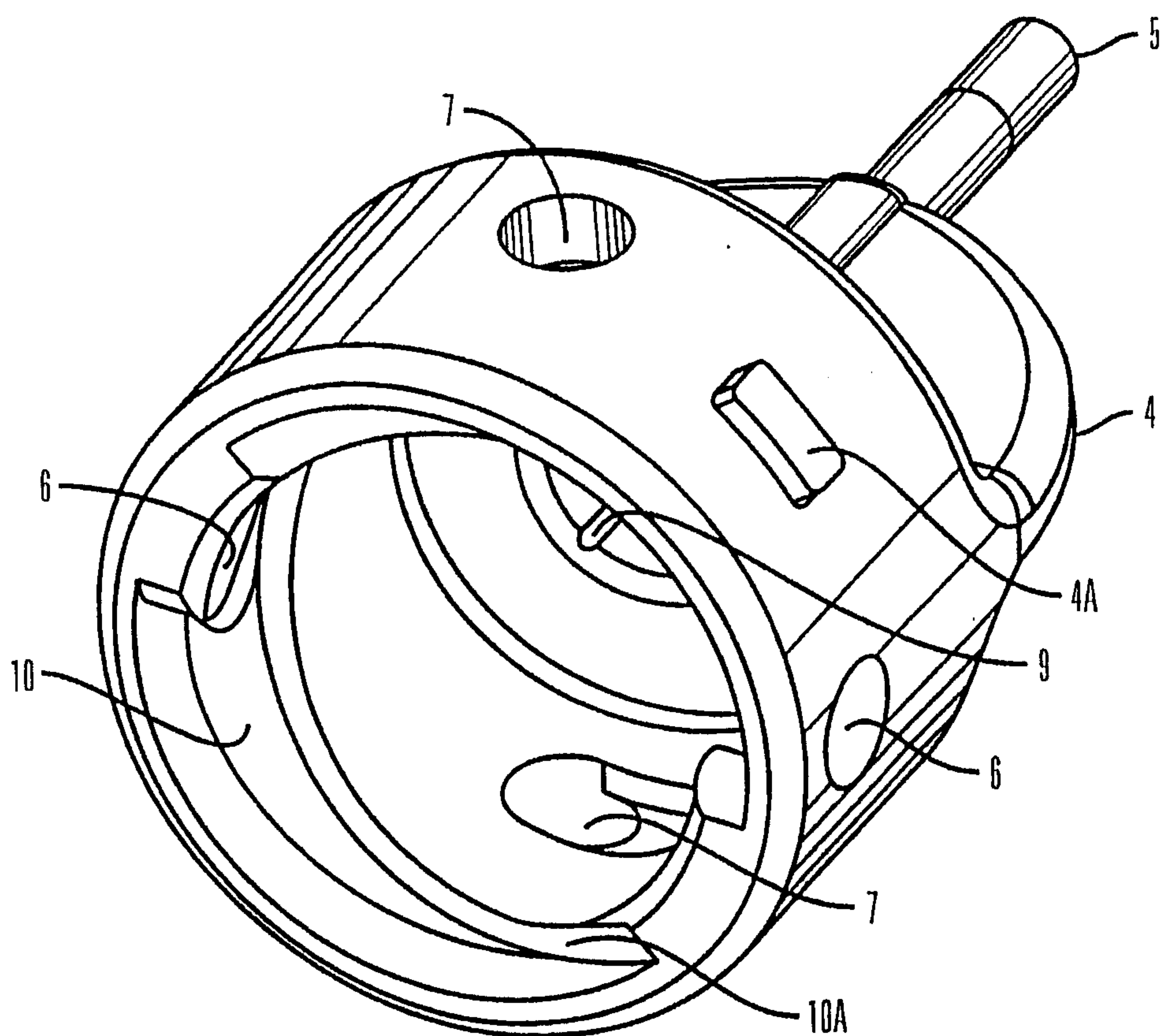

FIG. 2

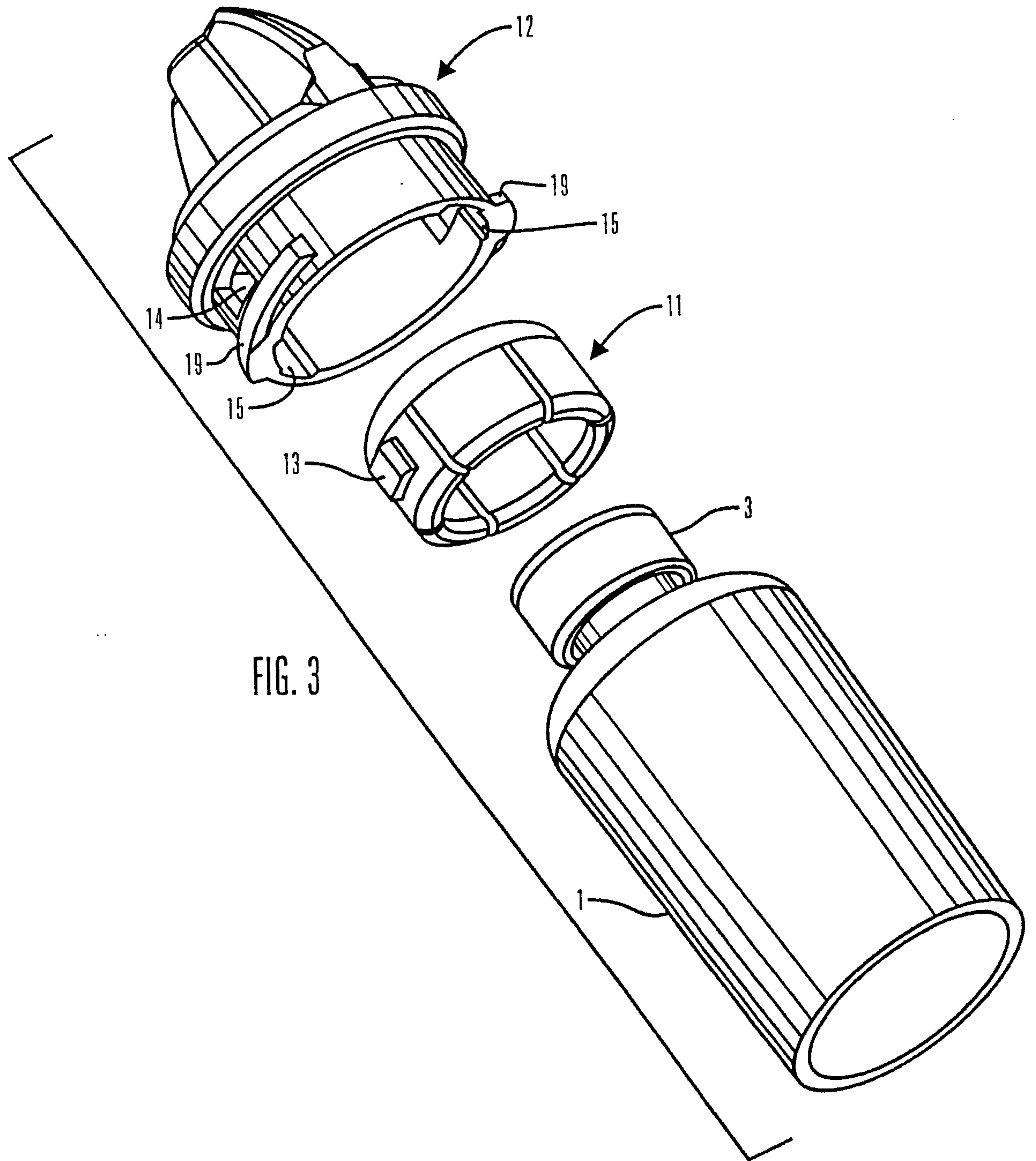

FIG. 3

4/14

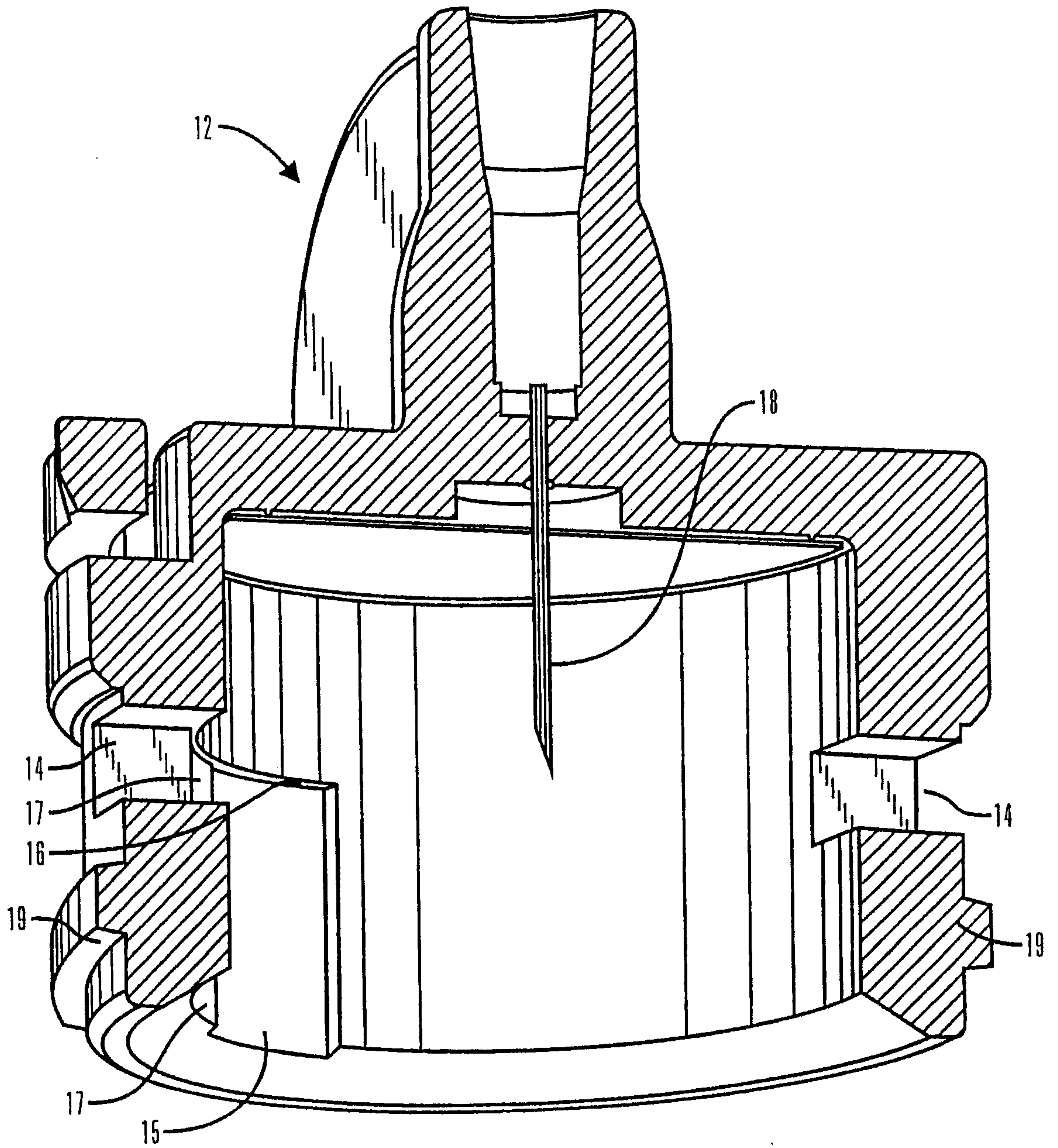

FIG. 4

5/14

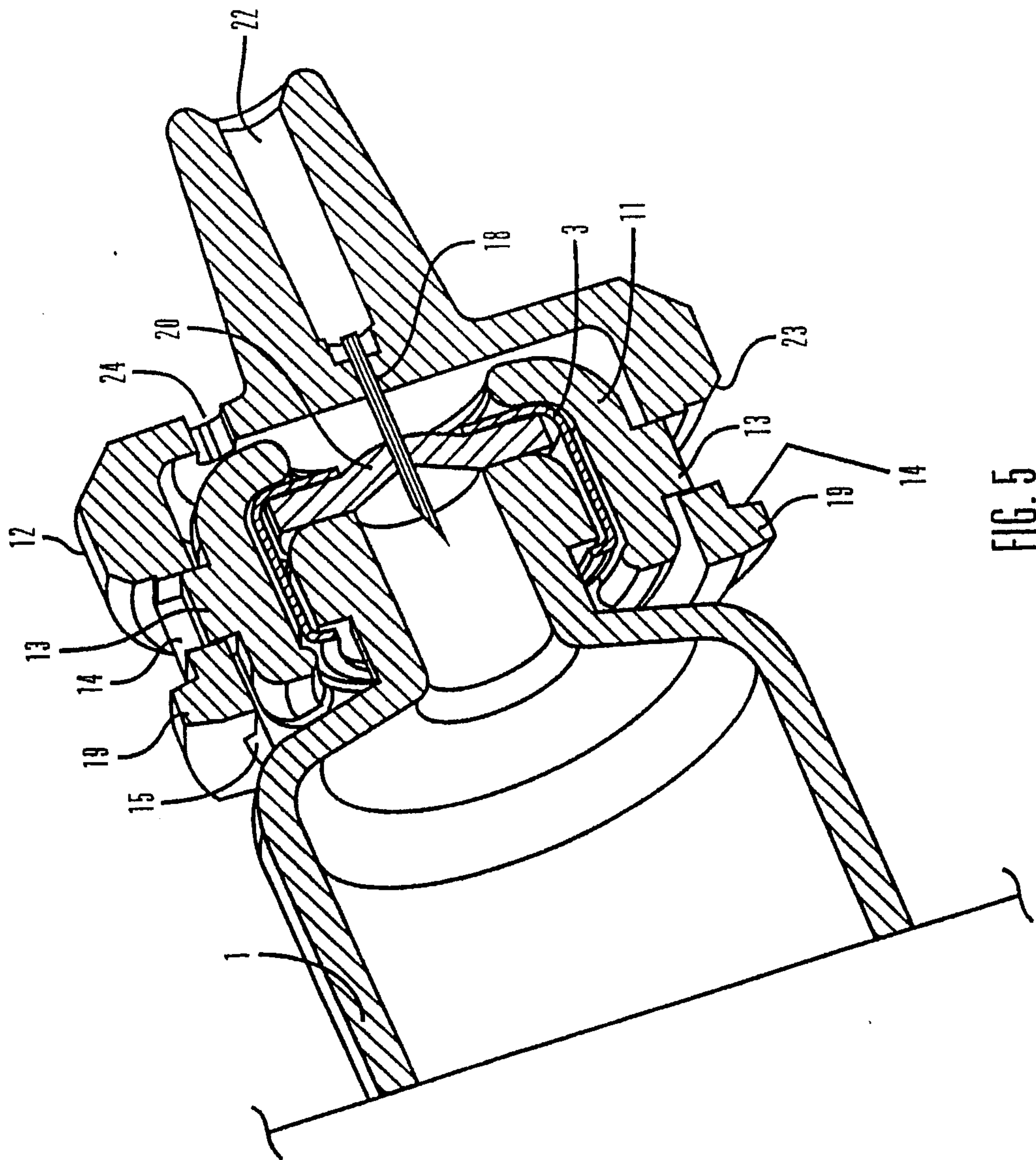
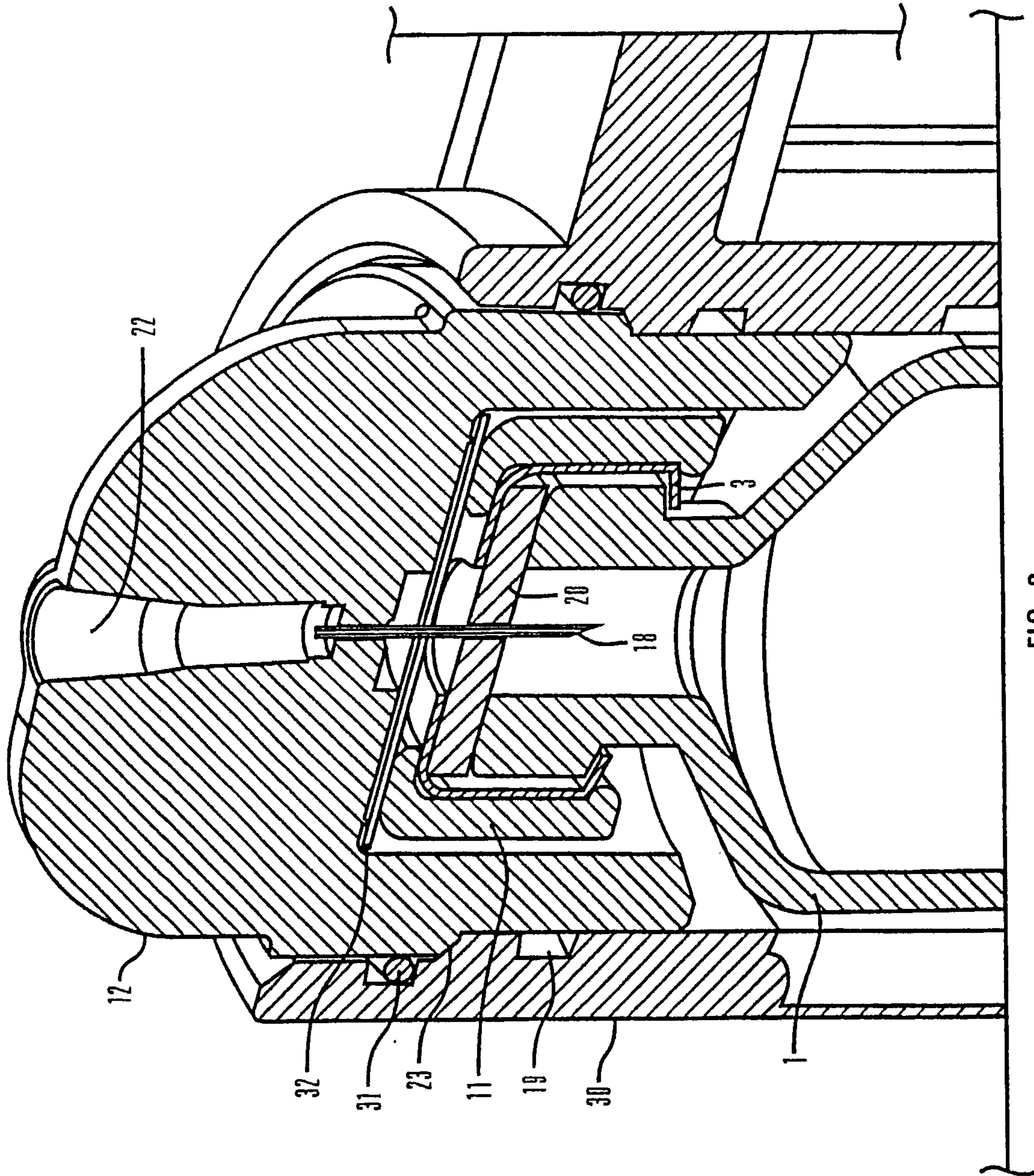

FIG. 5

6/14





7/14

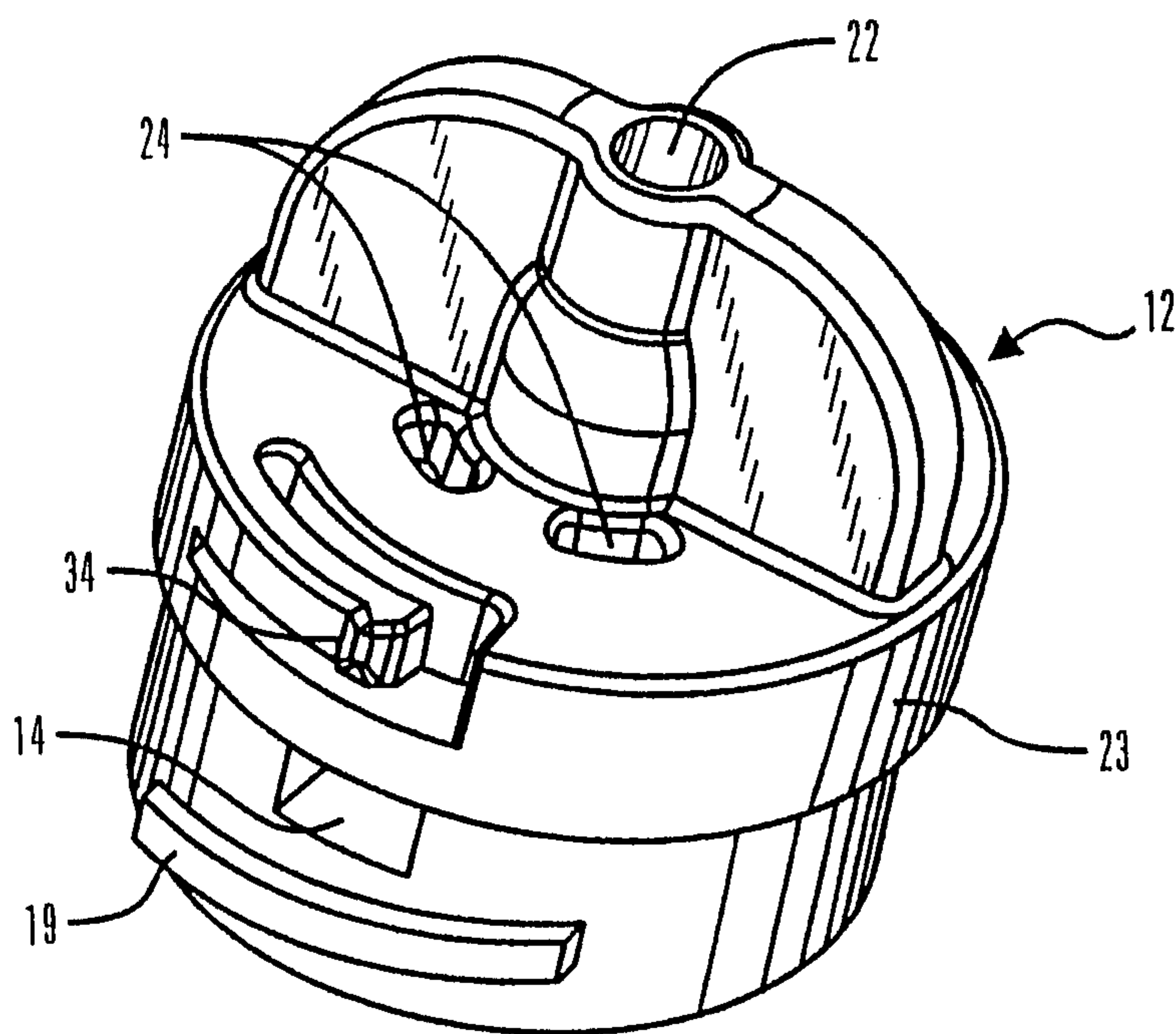

FIG. 7

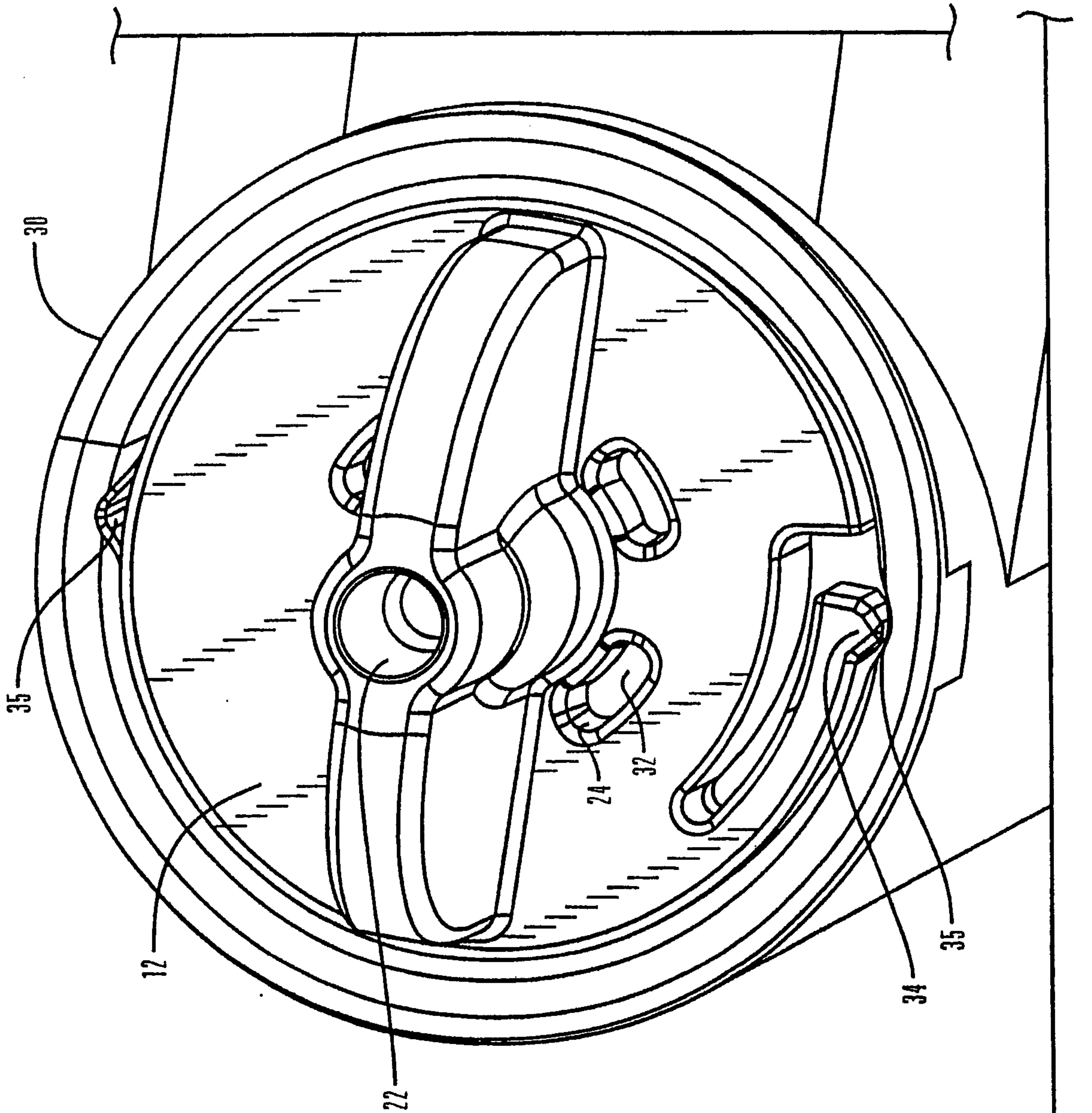

FIG. 8

9/14

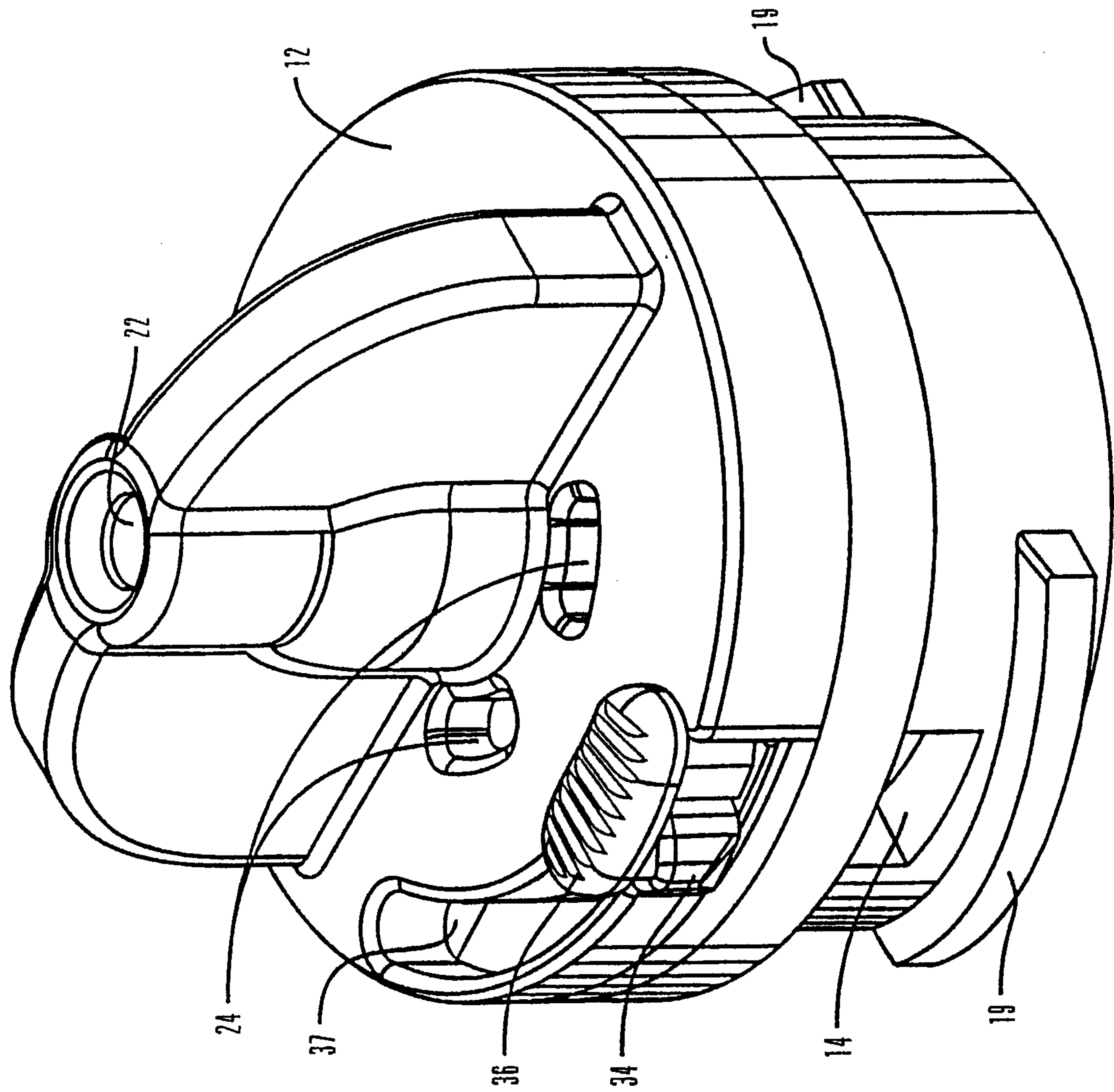

FIG. 9

10/14

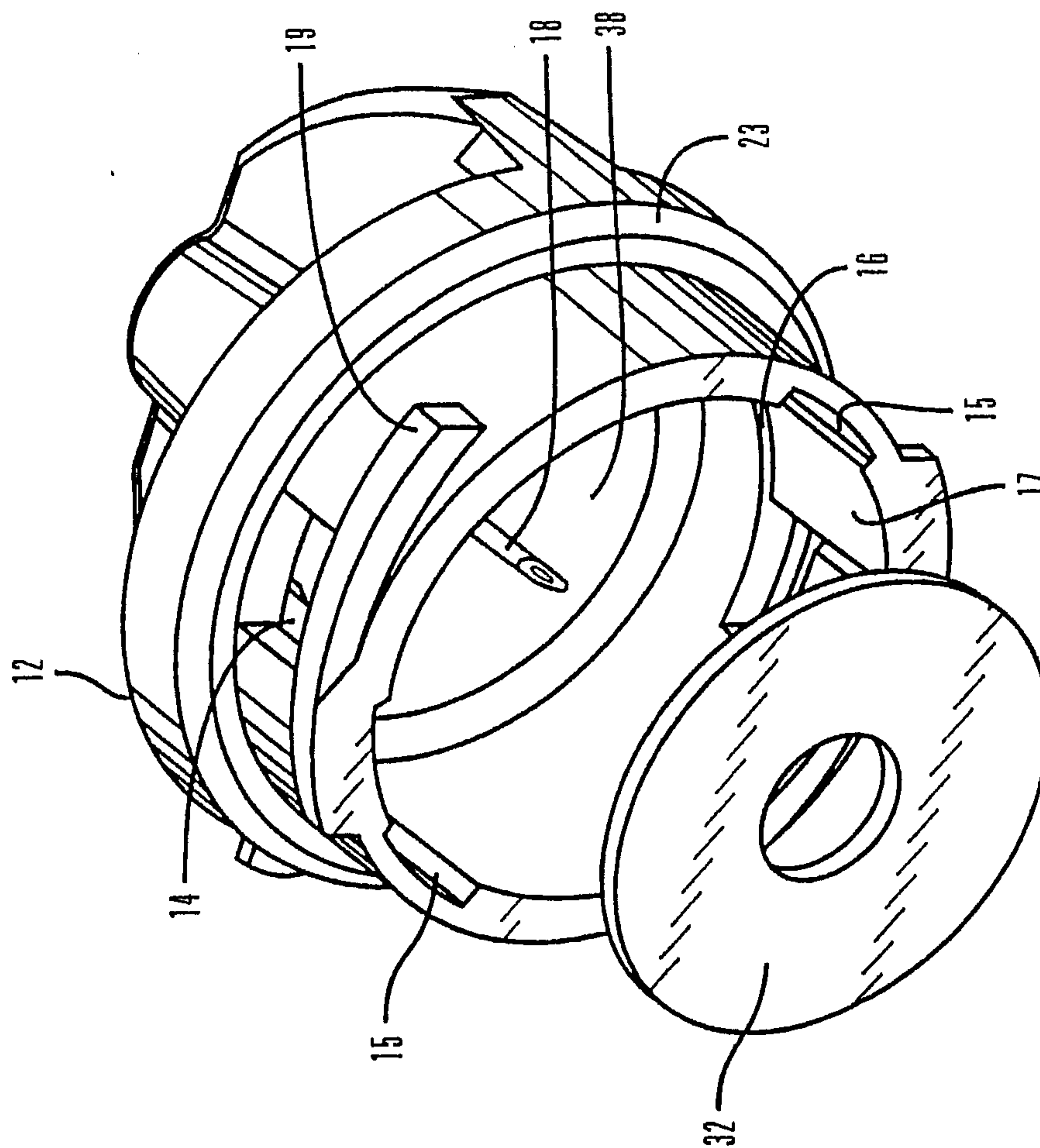

FIG. 10

11/14

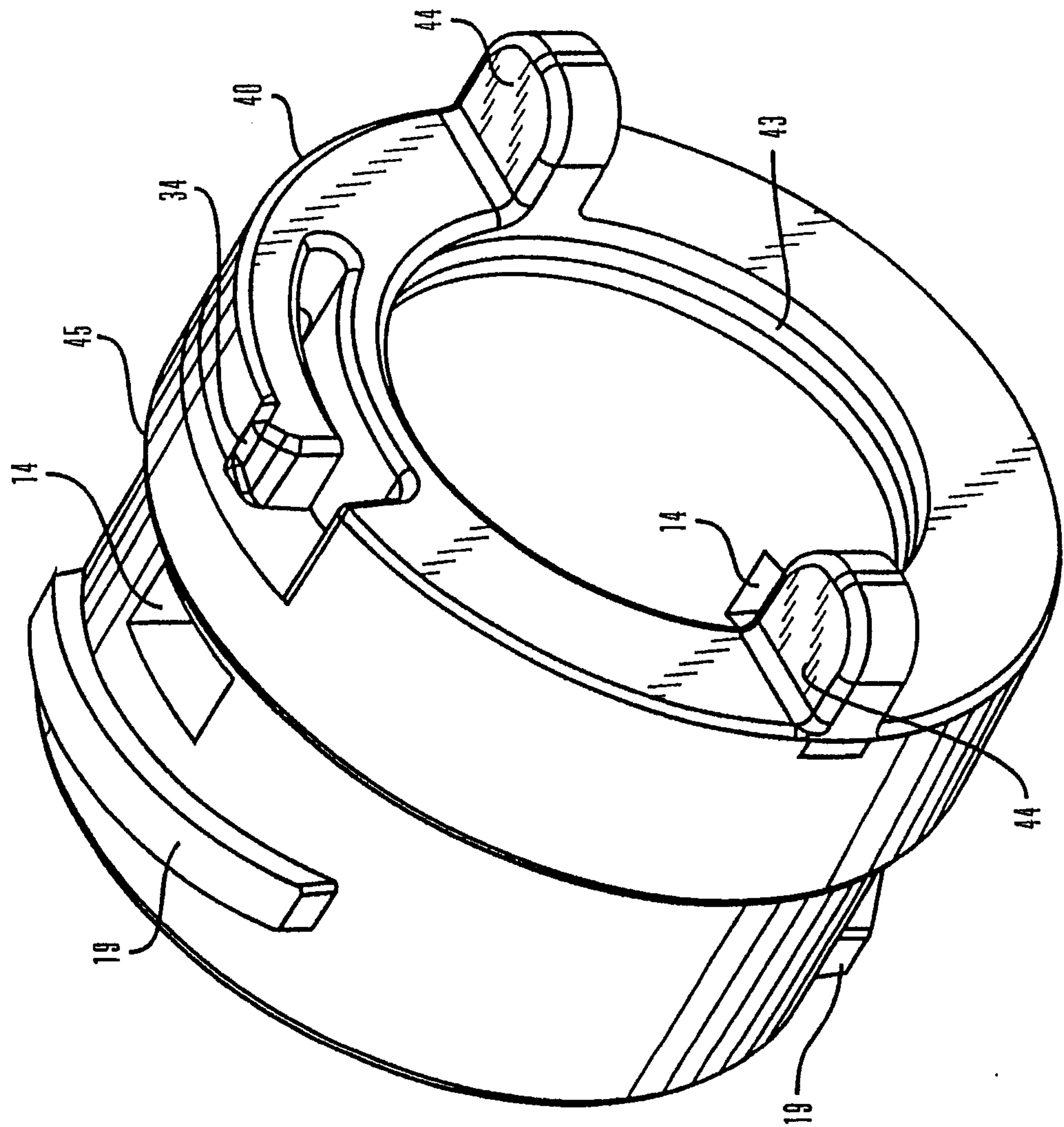
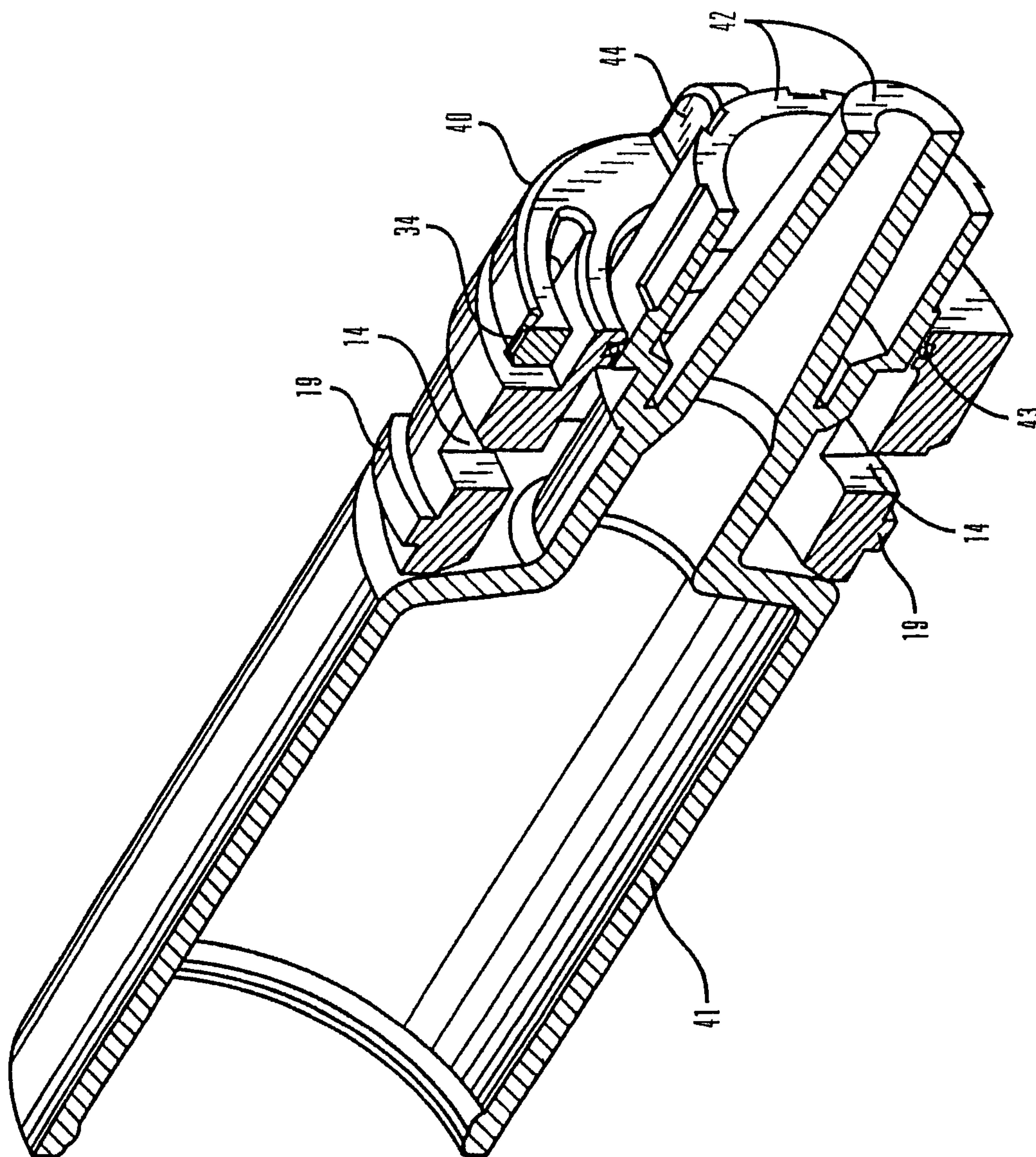

FIG. 11

12/14



13/14

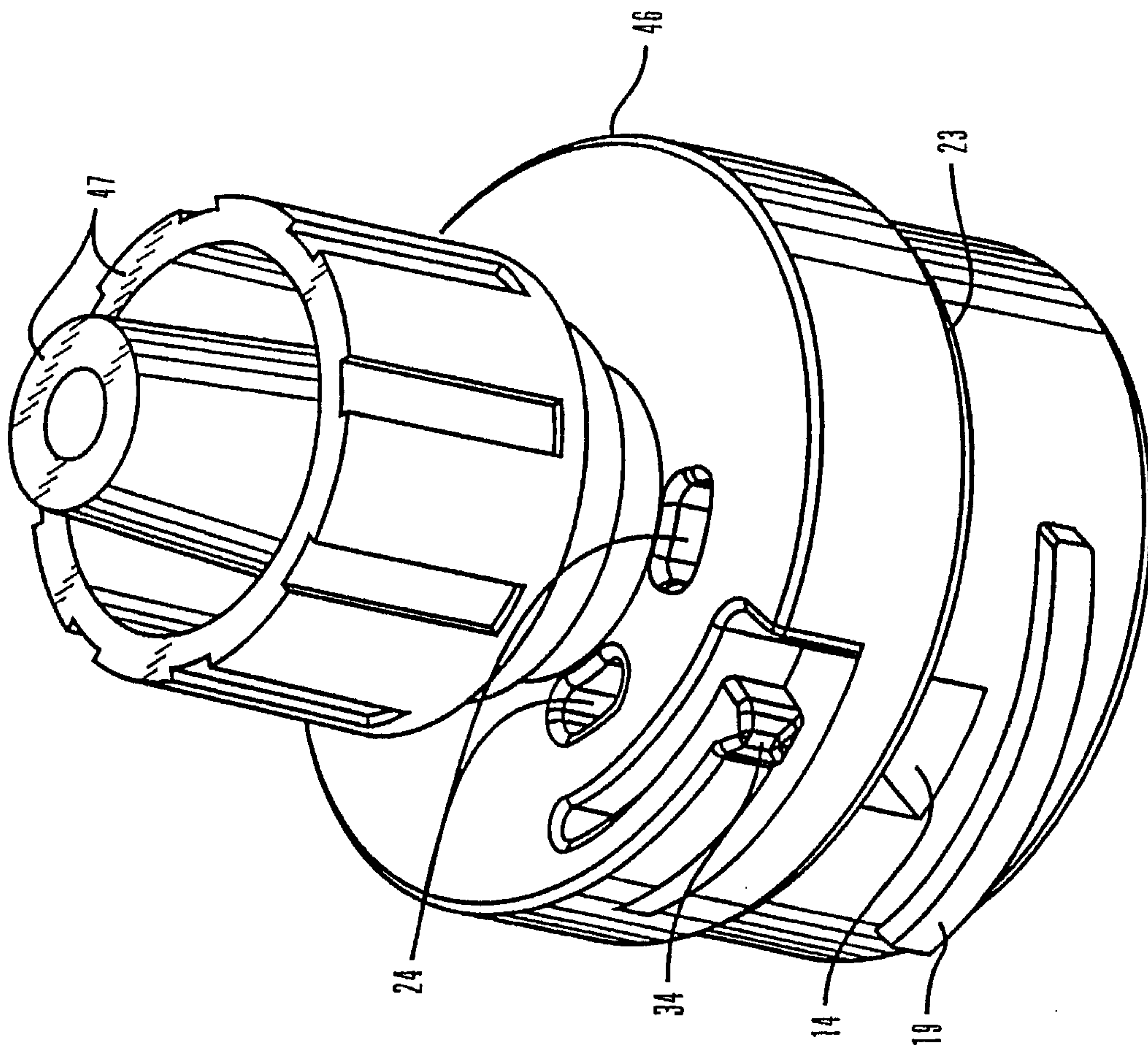

FIG. 13

14/14

