

No. 815,210.

PATENTED MAR. 13, 1906.

H. H. PATTEE.  
SPHERICAL AMUSEMENT VEHICLE.

APPLICATION FILED APR 11, 1905.

2 SHEETS—SHEET 1.

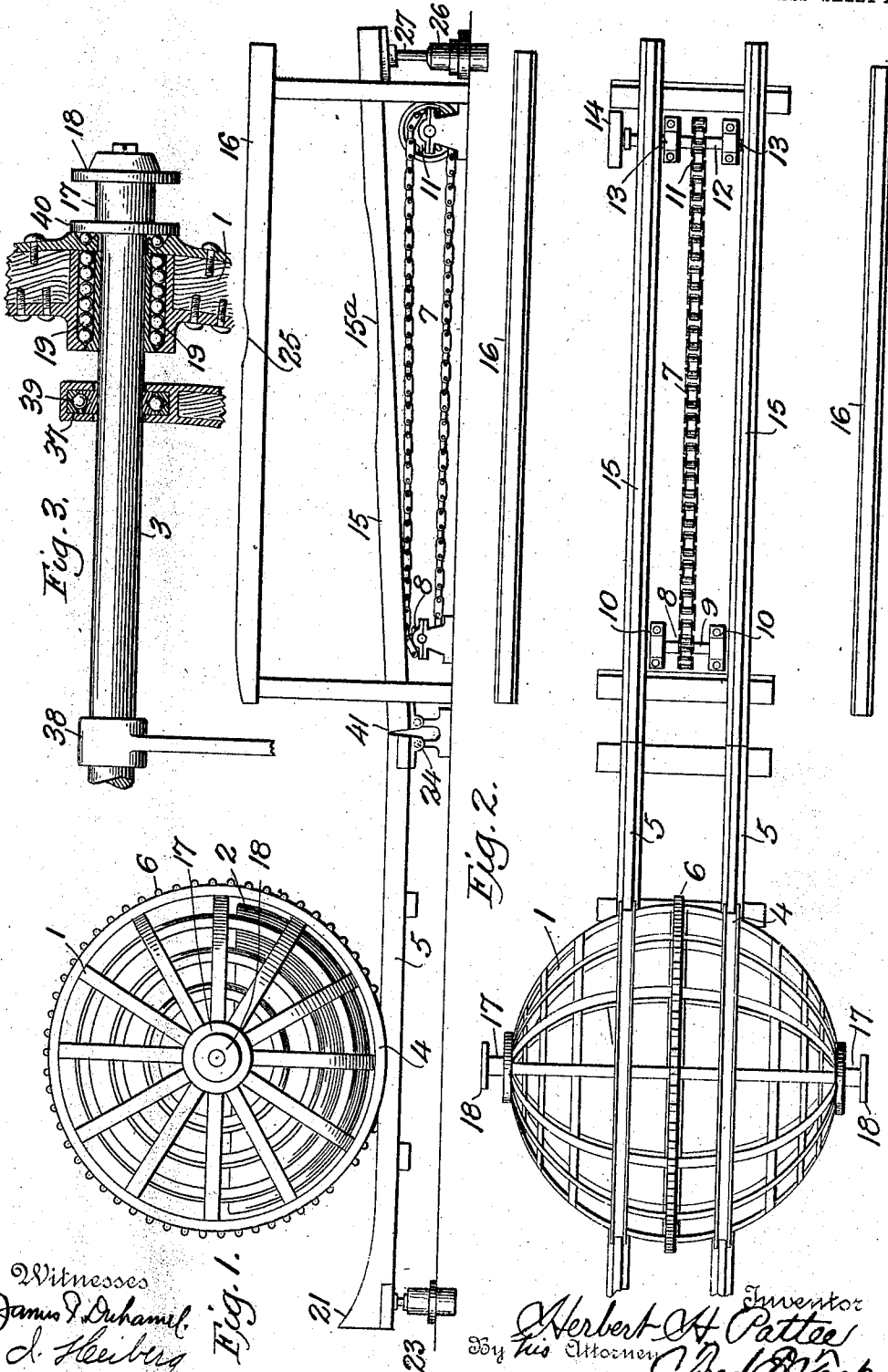

Witnesses  
James F. Duhamel.  
A. Heiberg

Fig. 1.

Inventor  
Herbert H. Pattee  
By his Attorney  
Fred Wacker.

No. 815,210.

PATENTED MAR. 13, 1906.

H. H. PATTEE.  
SPHERICAL AMUSEMENT VEHICLE.  
APPLICATION FILED APR 11, 1905.

2 SHEETS—SHEET 2.

Fig. 4.

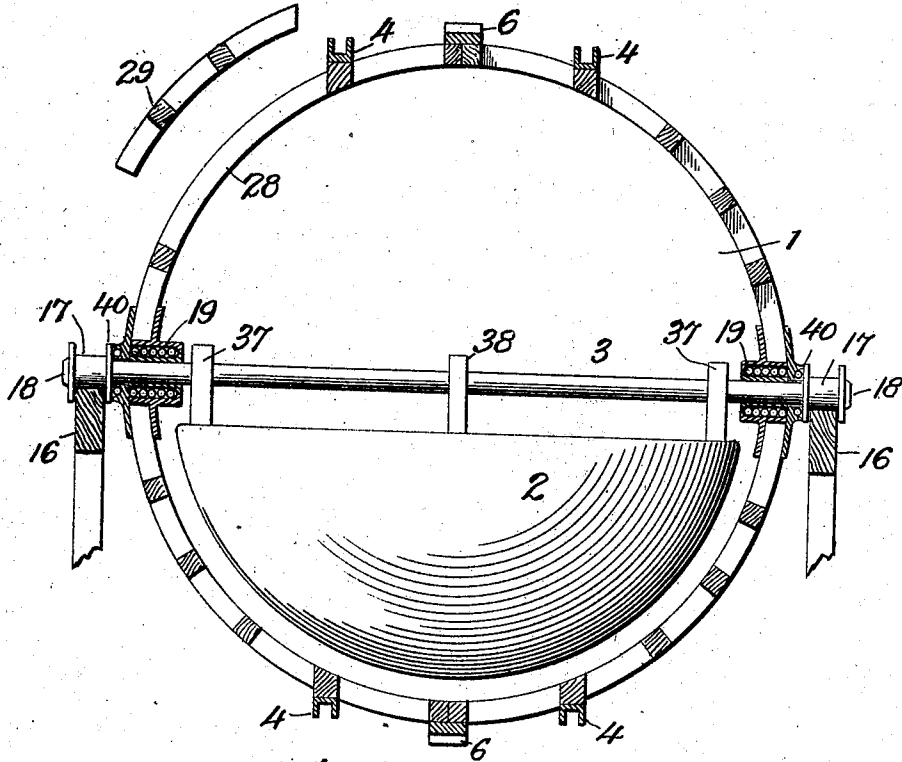
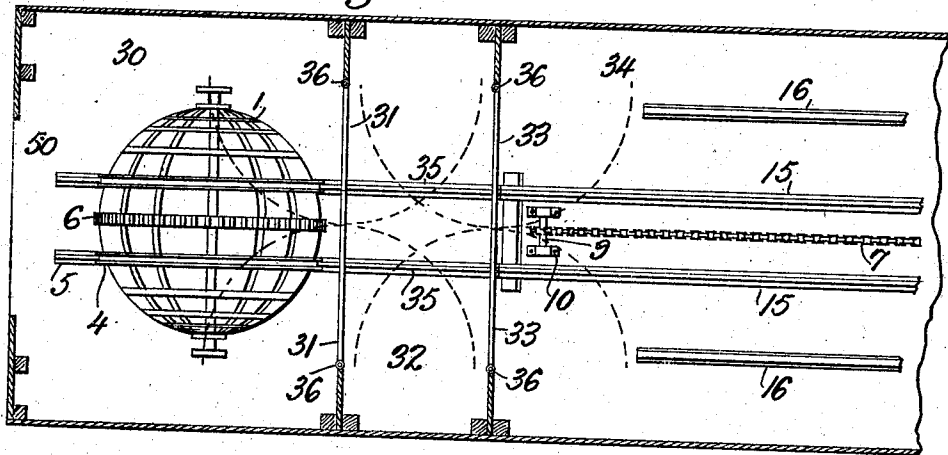

Fig. 5.



Witnesses  
James F. Duhamel,  
A. Fleisher

Inventor  
Herbert H. Pattee  
By his Attorney  
Fred W. Crocker.

# UNITED STATES PATENT OFFICE.

HERBERT H. PATTEE, OF NEW YORK, N. Y.

## SPHERICAL AMUSEMENT-VEHICLE:

No. 815,210.

Specification of Letters Patent.

Patented March 13, 1906.

Application filed April 11, 1905. Serial No. 254,961.

*To all whom it may concern:*

Be it known that I, HERBERT H. PATTEE, a citizen of the United States of America, and a resident of New York city, in the county of New York and State of New York, have invented certain new and useful Improvements in Spherical Amusement-Vehicles, of which the following is a specification.

My present invention has reference to certain novel and useful improvements in spherical whirling devices for use as amusement apparatus adapted to be employed in pleasure parks and at seaside resorts, exhibitions, fairs, and the like, the object of the invention being to provide a revolving ball or sphere carrying passengers therein and rolling both by gravity and the aid of mechanical means, as hereinafter described, so as to provide a sensational and startling but at the same time perfectly safe entertainment for those enjoying it.

The invention, therefore, consists, essentially, in the construction and combination of parts, and in numerous details and peculiarities thereof, substantially as will be hereinafter described and then more fully pointed out in the claims.

In the accompanying drawings, illustrating my invention, Figure 1 is a side elevation of my improved amusement apparatus. Fig. 2 is a top plan view of the same. Fig. 3 is a detail sectional view of the car-supporting shaft and one of the bearings of the latter in the wall of the ball. Fig. 4 is an enlarged cross-sectional view of the ball, showing the bowl or car supported on the axis. Fig. 5 is a sectional plan view of the entire apparatus, indicating the arrangement of tracks and the chambers or compartments, from one to the other of which the ball is transferred during the operation of the apparatus.

Like numerals of reference denote like parts throughout the different figures of the drawings.

In many respects the ball or sphere employed as a part of my present amusement device is similar to that shown and described in my former Letters Patent on ball-coaster, dated October 4, 1904, No. 771,322, though the present invention adds to said ball numerous features of value for the accomplishment of novel operations and the production of ingenious and sensational movements. The precise structure of the ball may vary within wide limits; but the example shown

in the drawings at 1 is a very convenient and preferable construction and consists, essentially, of a skeleton or foraminous shell through the interstices or openings in which persons riding within may readily gaze upon their surroundings. The shell consists of longitudinal ribs and latitudinal connections, there being openings between the latitudinal and longitudinal ribs to furnish an open-work construction, like a lattice-frame built in the shape of a sphere.

Inside of the ball 1 is a car 2 for carrying passengers, said car being preferably of a semispherical form (see Fig. 4) and the contour of the car conforming substantially to the general inner shape of the ball 1. The exact size and shape of the bowl-car 2 may vary within wide limits, and I do not wish to be restricted to what I have shown in the drawings.

3 denotes the axis of the ball 1, running centrally through the same and used to support the car 2. The wall of the ball 1 is provided with suitable ball-bearings 19 19 (see Figs. 3 and 4) for the shaft 3. Car 2 is hung upon shaft 3 inside the ball 1 by means of the end hangers 37 and one or more intermediate hangers 38, if such intermediate hangers should be found necessary. The end hangers 37, as also the intermediates, if preferred, are provided with ball-bearings, as shown at 39 in Fig. 3, so as to diminish the friction on the shaft 3. Car 2 may be weighted, if desired, in order to assist in keeping it level.

A car, like 2, hung as I have described will always remain level no matter how the external shell of the ball 1 may rotate, provided it rotates in such a way as to keep the axis 3 horizontal. Hence it may be said that the bowl or car 2 is always relatively stationary to the ball and always maintains a horizontal and level position however much the ball may revolve and rotate about it, and thus the passengers within the car 2 are never in danger of falling therefrom, for there is no possibility that car 2 should be overturned, so that by supporting the car in the manner I have described all danger of spilling the passengers and injuring them is avoided.

The ends of the axis 3 which project through the wall of the ball 1 outside the ball-bearings 19 are formed with trunnions 17, having next to the shell 1 rigid collars 40 and on the outer ends disks 18, which are parallel to the collars 40, so that in this way

the trunnions 17 are grooved and adapted to engage the rails 16 of an elevated stationary track on which the trunnions revolve at times and at other times remain stationary, while the ball 1 is being revolved on its axis, as will be presently explained.

Surrounding the external face of the shell 1 at points equidistant from a central plane are two grooved circular rims 4, designed to engage and roll upon a track, as the track 5, shown in Figs. 1 and 2. These grooved rims 4 when in engagement with the track cause the shaft or axis 3 to maintain a horizontal position, and hence the bowl 2, carrying the passengers, is not dislocated from its proper position of horizontality, which insures safety as an accompaniment to the pleasures entailed by the operation of the apparatus.

Referring to Figs. 1 and 2, it will be seen that the ball 1 rests upon a track composed of parallel rails 5 5, the grooved rims 4 of the ball being in engagement with the rails of the track. Obviously, the ball can easily roll along on said track when propelled by any agency. One end of the track is pivoted or hinged at 24. The other end is provided with a lifting device, as 23, whereby said end may be lifted higher than the pivoted end so as to cause the ball 1 to roll down the track toward the pivoted end by gravity. This device 23 may have a wide variety of forms, but one form which is to be preferred consists of a cylinder containing a piston operated by hydraulic pressure, which lifts the end of the track 50. A set of levers can be substituted therefor, if desired. The liftable end of the track is preferably provided with a stop 21, consisting of a curved riser, which will stop the motion of the ball on its return after it has been caused to roll back onto the track again by some returning agency. The track 5 may have any desired length; but in the contemplated operation of the ball as I am now describing it the length will be a moderate one, of only a few yards. Coinciding with the end of the track 5 is another track, consisting of parallel rails 15 15, said track being hinged or pivoted at 41 contiguous to the pivotal point 24. The other end of the track 15 is liftable by a device similar to that shown at 23, said device consisting, if desired, of a cylinder 26, containing a piston operating a rod 27, bearing against the under side of this end of the track and adapted to lift it from its horizontal position into an inclined one, where the ball can be influenced by gravity to roll back down the track 15 to the track 5, said track 15 being at times in a horizontal position and at other times in the inclined position indicated in Fig. 1. Between the rails 15 is an endless chain 7, passing around a sprocket-wheel 8, near one end of the track, and a sprocket-wheel 11 near the other end, said sprocket-wheel 11 being preferably somewhat larger than the sprocket-

wheel 8. The sprocket-wheel 8 is carried by shaft 9, supported in bearings 10 10, and the sprocket-wheel 11 is carried by shaft 12, supported in the bearings 13, the end of the shaft 12 being provided with a pulley 14, adapted to be belted to any suitable driving power. The smaller size of the sprocket-wheel 8 causes the chain 7 at the point where it passes around said wheel to be somewhat lower than at the place where it passes around the wheel 11, so that the ball is not engaged until after it has rolled a short distance over the chain. Surrounding the ball 1, and firmly secured thereto and made a part thereof on a vertical equatorial line is a circular rack, series of teeth or sprocket-wheel 6, adapted to mesh with the links of the chain 7, so that when the chain 7 is in engagement with the teeth 6 the ball 1 will be rotated in consequence. Therefore, assuming the track 15 to be horizontal, when the ball rolls there-onto and its teeth 6 catch the links of chain 7 the effect will be to rotate the ball, and such rotation will cause the ball to travel forward so long as the grooved rims 4 are in frictional contact with the rails 15; but when this contact ceases and the ball is supported by the trunnions 17 on the elevated rails 16 the action of the chain on the teeth 6 will be to rotate the ball at a high rate of speed proportionate to the operation of the motor driving the chain.

In the operation of the apparatus if the liftable end of track 5 be elevated sufficiently to cause the ball to gravitate along said track it will reach and roll onto the track 15, the latter then being horizontal, and when the grooved wheels 4 engage track 15 the grooved trunnions 17 will engage the elevated rails 16. The teeth 6 will engage the chain 7 as soon as the ball revolves the teeth to a point where the chain lies high enough to cause such engagement. The rails 15 are provided at a certain point with concave cuts 15<sup>a</sup>, and when the ball comes opposite said cuts the grooved wheels 4 will leave the tracks 15 for the time being, thereby throwing the entire weight of the ball and its contents upon the trunnions 17 which are in contact with the rails 16. Furthermore, it will be noted that rails 16 are provided with recesses 25, shallow in depth and intended merely to cause the trunnions 17 and the ball to come to a stop after or about the time the ball leaves the rails 15 and temporarily prevent the ball from rolling on beyond the concavities 15<sup>a</sup> and coming again into contact with the rails 15. While now the ball is suspended by the trunnions, the chain, being in engagement with the teeth 6, will rotate the ball upon its axis 3, the speed of rotation being regulated according to the action of the motor driving the chain. It will be understood that up to the point where the grooved wheels 4 meet the concavities 15<sup>a</sup> the ball

will have been rolling forward, and the occupants of the bowl 2 will have been appreciating the sensation of forward motion; but when the axis 3 comes to a stop on the rails 5 16 the ball 1 will pursue the same forward revolving motion, but this time on its axis and not moving rectilinearly, though the sensation produced upon the passengers will be exactly the same during this axial revolution 10 as during the forward rectilinear motion, the effect thus being illusory and the passengers seeming all the while to be riding forward in a rapidly revolving or rotating ball. When the revolution of the ball has continued as 15 long as may be desired, the chain-driving motor will be stopped, the mechanism for lifting the end of the rails 15 brought into play, and the rails lifted, which will cause the ball to gravitate back down the said rails 20 and again onto the track 5 up against the stop 21 and made to occupy the position shown in Fig. 1, where it is ready to receive other passengers. It may be remarked here that passengers will easily find ingress to the 25 bowl-car through the opening 28 in the side of the sphere 1, which opening is closed by the removable door 29.

In Fig. 5 I have indicated how the ball and the other parts of my amusement apparatus 30 may be practically arranged in connection with an inclosing structure for show purposes and for practical use with passengers. 30 designates a compartment into which the passengers first enter through the door 50. 35 In this compartment 30 is the track, consisting of rails 5, on which stands the ball 1, having the grooved rims 4 engaging rails 5. On the side of the compartment opposite the entrance-door 50 is a pair of light swinging doors 40 31. These doors lead to an intermediate compartment 32, which has on its opposite side a pair of similar swinging doors 33, which lead to another compartment 34. In the compartment 32 is a section of track consisting of rails 35 35 in line with the rails 5, 45 and in the compartment 34 a section of track consisting of rails 15 in line with rails 35, and this compartment also contains the elevated rails 16 for the ball-trunnions and the drive-chain 7 for rotating the ball. When 50 the end of the track 5 nearest the door 50 has been elevated, the car having previously been loaded with passengers, the ball will gravitate on the track 5 and striking against 55 the doors 31 will open the same, causing the ball to enter the compartment 32, through which it will be passed and will strike against the doors 33, opening them, and then enter the compartment 34. The doors 31 will 60 close before the doors 33 have been opened sufficiently to prevent passengers or bystanders in the compartment 30 from seeing what is going on in the dark compartment 34. The object of the double-door arrange- 65 ment is to so prevent an observance of the in-

terior of compartment 34. As soon as the ball reaches the rails 15 and the ball-trunnions, the elevated rails 16, the actuation of the ball will take place in the manner I have already described, being revolved as long as desired. 70 In the compartment 34 various effects, electrical and otherwise, may be utilized for the purpose of adding interest to the ride. Clouds of steam may come from the sides or 75 below, electrical lights may be lighted in the ball, deafening noises, like thunder, may be produced by mechanism not shown, and various illusions and stage effects created while the ball is continuing its ride. At the con- 80 clusion of the ride the ball will be caused to return to the chamber 30, passing the yielding doors 33 and 31 in a reverse manner to that in which it previously passed through them.

A wire-netting will usually be employed on 85 the side of the ball to cover the top of the bowl or car, so as to prevent passengers from putting their arms or heads into such a position as to be injured.

Very many changes in the precise construction and combination and arrangement of 90 parts may be made without departing from the invention, and I reserve the liberty of making such changes.

It must be noted particularly that the ball 95 revolves for a certain distance in a forward direction and that then it is received into a dark chamber, as 34, where the forward motion is stopped and the ball is supported on its axis and caused to be rotated rapidly on 100 said axis. As this axial rotation is performed in a dark chamber it is possible to deceive the occupants of the car into the belief that the forward motion of the ball, which it had outside in the light, is still continuing. Thus the 105 whole apparatus may be located and operated in a relatively small area of ground and yet apparently the passengers will be given a long ride. While the ball is moving in the open familiar objects are of course seen 110 through the foraminous wall; but as soon as it enters the dark compartment these objects disappear from view; but as the same revolving motion of the shell continues the passengers do not notice that the forward 115 motion of the axis or shaft has stopped and that the shell instead of rolling on its grooved rims is now rotating about said axis. This is a novel an ingenious result, which I achieve by my improved construction, and will be 120 found of great importance in an apparatus of this kind.

Having thus described my invention, what I claim as new, and desire to secure by Letters Patent, is— 125

1. A pleasure device, consisting of a ball carrying passengers, means for permitting the ball to gravitate for a certain distance, and means for revolving the ball on its axis.

2. An amusement apparatus comprising a 130

rolling ball carrying passengers, a track for the ball, and means for rotating the ball on its axis after it leaves the track.

3. An amusement apparatus comprising a rolling ball having a foraminous wall, in combination with internal means for carrying passengers, an axis for the ball on which the internal means is supported, and means for permitting the ball to gravitate without disturbing the horizontal position of the axis.

4. An amusement apparatus comprising a spherical rolling device having a foraminous wall, an axis, a car hung on the axis for carrying passengers, means for permitting the ball to roll while the axis remains horizontal, and means for rotating the ball on its axis.

5. An amusement apparatus comprising a spherical rolling device having a foraminous wall, a horizontal shaft in said device, a passenger-carrying car supported from the shaft, a track on which the ball rolls with its shaft in a horizontal position, and means consisting essentially of a chain engaging teeth on the ball for rotating the latter after it leaves the track.

6. An amusement apparatus comprising a ball carrying passengers, said ball pursuing a forward rolling motion at times and at other times having a revolution on its axis.

7. An amusement apparatus comprising a rolling ball, and a relatively stationary car within the ball, said ball rolling at times along a path and at other times being revolved on its own axis.

8. In an amusement apparatus, the combination with a track, of a rolling ball having a foraminous wall, and carrying passengers and provided with encircling rims that engage the track.

9. In an amusement apparatus, the combination with a track, of a rolling ball having a horizontal axis, a passenger-carrying car within the ball supported from said axis, and circular grooved pieces on the ball for engaging the track so that the axis of the ball may be kept horizontal.

10. The combination with a track, of a rolling ball having a horizontal axis, a relatively stationary car within the ball supported from the axis, and means for tilting one end of the track.

11. The combination with a hollow ball carrying passengers, the walls of which are constructed to permit passengers to see without, of means for revolving said ball on its axis.

12. An amusement apparatus comprising a rolling ball carrying passengers, the walls of which are constructed to permit the passengers to see without, and means for revolving the ball on its axis consisting essentially of a circular rack on the ball and means engaging said rack.

13. The combination with a rolling ball having a foraminous wall and having a hori-

zontal axis, of a relatively stationary car within the ball supported from the axis, a circular rack on the ball and a chain engaging said rack, and means for supporting the axis of the ball so that it may revolve on its axis.

14. An amusement apparatus comprising a rolling ball carrying passengers, a track for the ball, a horizontal shaft running through the ball and having trunnions on the end, means for supporting said trunnions at times, and means for revolving the ball when so supported consisting essentially of a circular series of teeth on the ball, and actuating means engaging the teeth.

15. The combination with a rolling ball having an axis, of a car within the ball for carrying passengers which car is hung on the axis to remain level while the ball rolls, a track engaged by grooves in the ball to permit the ball to roll forward at times, rails supporting the ends of the axis at other times, and means for rotating the ball on its axis when so supported.

16. In an amusement apparatus, the combination with a dark chamber, of a track leading thereinto, a ball carrying passengers and rolling on said track, said ball having an axis, means within the chamber for supporting the axis of the ball after it leaves the track, and means for rotating the ball on its axis so that the ball may appear to have a forward revolving motion both while rolling on the track and while rotating on its axis.

17. In an amusement apparatus, the combination with a spherical rolling device having a foraminous wall, of a horizontal axle the projecting ends of which serve as trunnions, a car hung on the axle for carrying passengers, a track engaged by encircling grooves on the rolling device, means for lifting the track so that the ball may gravitate thereon, and a second track for supporting the trunnions, and means for revolving the device on its axle when so supported.

18. In an amusement apparatus, a rolling ball carrying passengers, the walls of which are constructed to permit the passengers to see without, a track engageable by parallel encircling grooves on the ball equidistant from the center, a second track to which the ball passes from the first, an elevated track along said second track for supporting the axis of the ball when the grooves leave the second track, a circular rack on the ball, and endless chain engaging said rack so as to revolve the ball when supported by its trunnions.

19. In an amusement apparatus, the combination with a track, of a rolling ball, a relatively stationary car within the ball, and exterior flanges on the ball engaging the track.

20. In an amusement apparatus, the combination with a track or way, of a ball having encircling rims engaging the track or way, said ball being constructed to permit passen-

gers to see without, and a relatively stationary car within the ball, said car being hung on the axis of the ball.

21. In an amusement apparatus, the combination of an outer chamber, an inner chamber, an intermediate chamber, swinging doors between the outer chamber and the intermediate chamber, and swinging doors between the intermediate chamber and the inner chamber, a track running through the several chambers, a ball carrying passengers and rolling on said track, said ball having an axis, means within the inner chamber for supporting the ball after it leaves the track, and means for rotating the ball while off the track so that it may appear to have the same forward motion as when rolling on the track.

22. In an amusement apparatus, the combination with an inner chamber, of a track leading thereinto, doors to said chamber, a ball carrying passengers and rolling on said track and opening the doors by contact therewith automatically, said ball having an axis, means within the chamber for supporting the axis of the ball after it leaves the track, and means for revolving the ball when so supported so that it will appear to have the same forward motion as when rolling on the track.

23. In an amusement apparatus, the combination of an outer chamber having hinged doors, an inner chamber having hinged doors,

a chamber intermediate between the two aforesaid chambers, a track leading through the chambers, a ball carrying passengers and rolling on said track and automatically opening the doors by contact therewith, said ball having encircling rims that engage the track, and means for lifting the ball from the track in the inner chamber and rotating it when so lifted.

24. The combination with a hollow ball carrying passengers and having a foraminous wall, of means for revolving said ball on its axis, and encircling rims on the ball which engage a track or way.

25. The combination with a hollow ball carrying passengers, the walls of which are constructed to permit passengers to see without, a track, means for lifting the ball off the track, and means for rolling the ball on the track and likewise for revolving it when off the track.

26. The combination with a foraminous ball, of a relatively stationary car within the same carrying passengers, and means for rotating the ball about its axis.

Signed at New York this 8th day of April, 1905.

HERBERT H. PATTEE.

Witnesses:

JOHN H. HAZELTON,  
I. HEIBERG.