

(19) World Intellectual Property Organization
International Bureau



(43) International Publication Date
7 March 2002 (07.03.2002)

PCT

(10) International Publication Number
WO 02/19211 A1

(51) International Patent Classification⁷: G06F 17/60

(21) International Application Number: PCT/US01/26718

(22) International Filing Date: 27 August 2001 (27.08.2001)

(25) Filing Language: English

(26) Publication Language: English

(30) Priority Data:
09/648,877 28 August 2000 (28.08.2000) US

(71) Applicant: **MICROCREDITCARD.COM, INC.**
[US/US]; 1655 N. Ft. Meyer Drive, Suite 700, Arlington,
VA 22209 (US).

(72) Inventors: **WILLIAMS, Christopher, K.**; 1410 N. Scott
Street, Apt. 563, Arlington, VA (US). **KAYATIN, Justin,
M.**; 1000 Fell Street, Apt. 404, Baltimore, MD (US).

(74) Agents: **MILLER, Charles, L.** et al.; Banner & Witcoff,
Ltd., Ten South Wacker Drive, Suite 3000, Chicaco, IL
60606-7407 (US).

(81) Designated States (*national*): AE, AG, AL, AM, AT, AU, AZ, BA, BB, BG, BR, BY, BZ, CA, CH, CN, CO, CR, CU, CZ, DE, DK, DM, DZ, EC, EE, ES, FI, GB, GD, GE, GH, GM, HR, HU, ID, IL, IN, IS, JP, KE, KG, KP, KR, KZ, LC, LK, LR, LS, LT, LU, LV, MA, MD, MG, MK, MN, MW, MX, MZ, NO, NZ, PH, PL, PT, RO, RU, SD, SE, SG, SI, SK, SL, TJ, TM, TR, TT, TZ, UA, UG, UZ, VN, YU, ZA, ZW.

(84) Designated States (*regional*): ARIPO patent (GH, GM, KE, LS, MW, MZ, SD, SL, SZ, TZ, UG, ZW), Eurasian patent (AM, AZ, BY, KG, KZ, MD, RU, TJ, TM), European patent (AT, BE, CH, CY, DE, DK, ES, FI, FR, GB, GR, IE, IT, LU, MC, NL, PT, SE, TR), OAPI patent (BF, BJ, CF, CG, CI, CM, GA, GN, GQ, GW, ML, MR, NE, SN, TD, TG).

Declarations under Rule 4.17:

- as to applicant's entitlement to apply for and be granted a patent (Rule 4.17(ii)) for all designations
- as to the applicant's entitlement to claim the priority of the earlier application (Rule 4.17(iii)) for all designations

Published:

- with international search report

[Continued on next page]

(54) Title: THIRD-PARTY BILLING SYSTEM AND METHOD

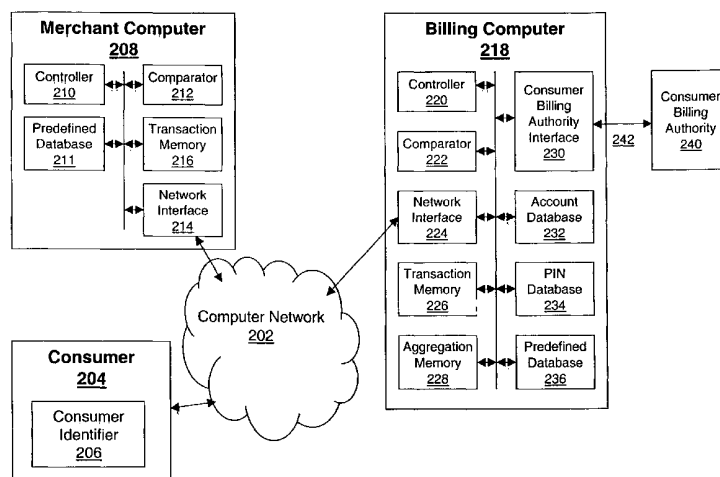

(57) **Abstract:** A third-party billing system and method permits consumers to conduct e-commerce transactions including micro-transactions securely and anonymously by providing billing and personal information to the third party billing system rather than to merchants. A consumer initiates a transaction by placing an order for a product. The consumer (204) then authorizes the transaction by transmitting an authorization code to a billing computer (218). The authorization code identifies the consumer billing account to which the transaction is to be charged. The authorization code can also authenticate the consumer through a PIN. Multiple consumers can charge transactions to one billing account in which case each consumer can be assigned a different PIN with restrictions that limit that consumer's use of the account. The billing computer (218) then verifies the authorization code and transmits an approval code to the merchant computer (208). Consumer (204) has an associated consumer identifier (206) that uniquely identifies the consumer while the consumer interacts with computer network (202) and is independent from the consumer's billing information that is provided to consumer billing authority (240).

WO 02/19211 A1



— *before the expiration of the time limit for amending the claims and to be republished in the event of receipt of amendments*

For two-letter codes and other abbreviations, refer to the "Guidance Notes on Codes and Abbreviations" appearing at the beginning of each regular issue of the PCT Gazette.

THIRD-PARTY BILLING SYSTEM AND METHOD

FIELD OF THE INVENTION

5 The present invention relates to electronic commerce systems and methods, and more specifically, to a third-party billing system and method that allows consumers to purchase products and services from online merchants by providing billing information to the third party billing system rather than to merchants.

BACKGROUND OF THE INVENTION

10 Consumers are ordering products and services over computer networks such as the Internet in increasing numbers. Figure 1 shows a typical electronic commerce (e-commerce) system used to conduct online transactions. Consumer 104 usually accesses a computer network such as the Internet through a browser program, and searches through product descriptions located at a merchant's world wide web site on merchant computer 108. After consumer 104 selects a product and places an order for it with merchant computer 108, consumer 104 typically sends
15 billing information (such as a credit card number), as well as additional personal information (such as a postal address, a telephone number, or an e-mail address), to merchant computer 108. Merchant computer 108 then requests authorization from consumer billing authority 140 (e.g., a credit card payment processor) to charge the transaction to a consumer billing account identified by the billing information provided by consumer 104. After receiving authorization from
20 consumer billing authority 140, merchant computer 108 notifies consumer 104 that the transaction has been authorized, and delivers the product to consumer 104.

25 There are numerous drawbacks associated with such prior art e-commerce systems. For example, consumers must provide their billing information to all the merchants from whom they wish to purchase products or services. This poses a security risk to consumers, since unscrupulous merchants can use that information to conduct unauthorized transactions. Moreover,
30 consumers must also provide their personal information to merchants, who can use that identifying information to flood consumers with unsolicited mail, telephone calls, and advertisements. Merchants can also sell consumers' personal information, as well as information about the products or services purchased by specific consumers, to advertising companies or to companies that can compile detailed histories of the spending and purchasing habits of

consumers. Many potential consumers are reluctant to engage in online transactions for fear that in doing so they can compromise not only the security of their billing accounts, but also their own privacy.

5 Merchants are also inconvenienced by prior art e-commerce systems because they must implement their own billing solution, which can be costly, time consuming, and technically difficult to integrate into their web site. In addition, merchants must also build extra security mechanisms into their web site in order to prevent hackers from breaking into their system and gaining access to databases with consumer account and billing information.

10 Another drawback of prior art e-commerce systems is that they are not set up to handle "microtransactions." Microtransactions are transactions that involve small amounts of money, such as two dollars or less. The relatively high fees associated with processing such transactions prohibit merchants from making microtransactions available to consumers. This is an especially significant shortcoming on the Internet because consumers are much more likely to buy small-value items (such as a \$0.50 news article, picture, or song) than large-value items (such as a \$20 newspaper subscription or album).

15 Accordingly, there exists a need for an electronic commerce system and method that allows consumers to conduct transactions securely, confidentially, and without the aforementioned problems and inconveniences.

SUMMARY OF THE INVENTION

20 The present invention is directed to a system and method for conducting transactions between a consumer, a merchant computer, and a billing computer that are connected together by a computer network. In a typical transaction, the consumer wishes to purchase a product or service from the merchant computer. The product or service can comprise digital content. Non-limiting examples of digital products include online publications, digital images, computer software, search results obtained from searching electronic databases, and any other information that merchants can provide to consumers for a fee. The consumer intends to pay for the product or service by charging the transaction to a consumer billing account, preferably one that has been pre-established (e.g., an existing credit card). Examples of billing accounts include credit card accounts, debit card accounts, smart card accounts, checking accounts, and any account that allows consumers to pay for a purchase by merely providing an identification of the account to a merchant or other party. The system and method of the present invention allow consumers to conduct such transactions without disclosing the identity of a billing account (or other

information related to the account) to merchants. Instead, consumers provide such billing information to a trusted third-party billing system.

The advantages of the present invention are provided by a method of conducting transactions that includes the steps of initiating a transaction, authorizing the transaction by having the consumer transmit an authorization code to the billing computer, and fulfilling the transaction.

The transaction can be initiated by transmitting an order for a product or service to a merchant computer. The merchant computer can transmit information relating to the order to a billing computer, which can respond by returning a transaction identification code. The merchant computer can transmit the transaction identification code to the consumer, and direct the consumer to contact the billing computer in order to authorize the transaction. In an alternative embodiment, the transaction can be predefined, and the merchant computer can return a transaction identification code to the consumer without first contacting the billing computer. In yet another embodiment, the consumer can initiate a predefined transaction by placing an order directly with the billing computer.

The transaction is then authorized by the consumer. The billing computer can transmit a description of the transaction to the consumer, so as to verify the details of the transaction. Assuming the consumer wishes to authorize the transaction, the consumer transmits an authorization code to the billing computer. The authorization code contains billing information that identifies the consumer billing account to which the consumer wishes to charge the transaction. The authorization code can also contain authentication information such as a password or a Personal Identification Number (PIN), which adds a layer of security to the consumer's billing account. In an alternative embodiment in which multiple consumers are permitted to charge transactions to the same billing account, each consumer is issued a separate PIN. Each PIN can be associated with restrictions that limit the corresponding consumer's use of the billing account.

After the consumer authorizes the transaction, the billing computer determines whether to approve the transaction. The billing computer makes such a determination by considering the authorization code provided by the consumer. The billing computer can also consider authentication information provided by the consumer, as well as other information about the transaction. The billing computer can also consider the result of an authorization request placed with a consumer billing authority before approving the transaction. After the billing computer makes its approval determination, it transmits an approval code to the merchant computer, indicating whether or not it has approved the transaction.

Assuming the transaction is approved by the billing computer, it is then fulfilled. Transaction fulfillment can be as simple as delivery of the product or service to the consumer. The merchant computer can additionally send an acknowledgment to the billing computer.

5 In an alternative embodiment, the consumer transmits a fulfillment request and a consumer identifier (sufficient to associate the consumer with the transaction but not necessarily to reveal the true identity of the consumer) to the merchant computer. The consumer also transmits the consumer identifier to the billing computer, possibly as part of the authorization code. The billing computer forwards its copy of the consumer identifier to the merchant computer. If the consumer identifier received from the consumer matches the consumer identifier received from
10 the billing computer, the merchant computer then delivers the product to the consumer at the destination specified by the consumer identifier.

In another embodiment, the consumer transmits a fulfillment request and a consumer identifier to the merchant computer. The merchant computer then transmits the consumer identifier to the billing computer, along with a fulfillment approval request. The consumer also
15 transmits a consumer identifier to the billing computer, possibly as part of the authorization code. If the consumer identifier received from the consumer matches the consumer identifier received from the merchant computer, the billing computer transmits a fulfillment approval response to the merchant computer indicating approval to fulfill the transaction. If the consumer identifiers do not match, the billing computer transmits a fulfillment approval response that
20 indicates denial to fulfill the transaction. Assuming the fulfillment approval response is positive, the merchant computer then delivers the product or service to the consumer.

The billing computer can charge the transaction to the consumer billing account by transmitting a charge submission to a consumer billing authority. Alternatively, the billing computer can aggregate two or more transactions, and charge the aggregated transactions to the
25 consumer billing account upon the occurrence of a specified event. Aggregation amortizes processing fees across multiple transactions, thereby making microtransactions profitable for merchants. The system and method of the present invention thus enable merchants to offer microtransactions to consumers. In another embodiment, the billing computer can use predetermined criteria to determine whether each transaction is to be charged directly to the
30 consumer billing account, or aggregated with other transactions and charged to the consumer billing account as an aggregate total.

In an alternative embodiment, the billing computer can obtain a pre-authorization from the consumer billing authority that permits the charging of a predetermined amount to the

consumer billing account. Pre-authorization further enables aggregation by ensuring that a consumer billing account can accommodate the charging of aggregated transactions.

In a preferred embodiment, a consumer pre-registers with a billing computer and identifies a credit card account and a personal identification number (PIN) that are to be used to charge transactions. Thereafter, the consumer initiates a transaction by accessing a merchant's web site and placing an order for a product. The merchant computer receives the order and sends information relating to the order to the billing computer, which acts as a third-party billing system. The billing computer creates a transaction corresponding to the order and sends a corresponding transaction identifier to the merchant computer. The merchant computer receives the transaction identifier and transmits a copy to the consumer. The merchant computer then redirects the consumer to the billing computer's web site to authorize the transaction.

The consumer authorizes the transaction by sending the transaction identifier and an authorization code comprising a pre-registered credit card number, a PIN, and a zip code to the billing computer. The consumer also sends an anonymous consumer identifier, such as an Internet Protocol (IP) address, to the billing computer. The billing computer verifies the authorization code and determines whether to approve the transaction. The billing computer then transmits an approval code to the merchant computer, indicating whether the transaction has been approved. The billing computer also redirects the consumer back to the merchant computer's web site. The consumer sends a fulfillment request to the merchant computer, along with a copy of the anonymous consumer identifier. The merchant computer checks to see whether the billing computer has approved the transaction, and whether the consumer identifier sent by the consumer matches the consumer identifier sent by the billing computer. If the transaction has been approved and the consumer identifiers match, the merchant computer electronically transmits the product to the IP address specified by the consumer identifier. The merchant computer then sends an acknowledgment to the billing computer that the product has been delivered. The billing computer either submits the transaction to a consumer billing authority, thereby directly charging the transaction to the credit card account specified in the consumer's authorization code, or aggregates the transaction for later billing to the credit card account as part of an aggregate total.

One advantage of the present invention is that it allows consumers to conduct transactions securely by providing billing information to a third-party billing system rather than to merchants.

Another advantage of the present invention is that it allows consumers to conduct transactions anonymously by providing personal information to a third-party billing system rather than to merchants.

5 Yet another advantage of the present invention is that it allows consumers to add security to their billing account by associating a PIN code with it.

Yet another advantage of the present invention is that it allows multiple consumers to charge transactions to a billing account, and to allow different restrictions to be set for each consumer on the transactions that can be charged by that consumer.

10 A further advantage of the present invention is that it allows consumers to conduct transactions without needing to create or remember a new account number.

Yet another advantage of the present invention is that it allows consumers and merchants to conduct microtransactions.

A further advantage of the present invention is that it allows transactions to be aggregated before being charged to a consumer billing account.

15 Another advantage of the present invention is that it allows a billing account to accommodate aggregated charges by obtaining pre-authorization to charge a predetermined amount to the consumer billing account.

20 The foregoing and other features, aspects, and advantages of the present invention will become apparent from the following detailed description, which should be read in conjunction with the accompanying drawings.

BRIEF DESCRIPTION OF THE DRAWINGS

The accompanying drawings, which are incorporated into and form a part of the specification, illustrate preferred embodiments of the present invention by way of example, and, together with the description, serve to explain the principles of the invention.

25 Figure 1 is a schematic diagram of a prior art e-commerce system.

Figure 2 is a schematic diagram of an e-commerce system in accordance with a preferred embodiment of the invention.

Figure 3 illustrates the communications that can occur as part of the step of initiating a transaction in a preferred embodiment of the method of the present invention.

30 Figure 4A illustrates the communications that can occur as part of the step of authorizing a transaction in a preferred embodiment of the method of the present invention.

Figures 4B and 4C depict web pages through which a consumer authorizes a transaction in a preferred implementation of the system and method of the present invention.

Figure 5 illustrates the communications that can occur as part of the step of approving a transaction in a preferred embodiment of the method of the present invention.

5 Figures 6A and 6B illustrate the communications that can occur as part of the step of fulfilling a transaction in a preferred embodiment of the method of the present invention.

DETAILED DESCRIPTION OF THE PREFERRED EMBODIMENTS

The present invention will now be described with reference to the accompanying drawings, which are provided as illustrative examples of preferred embodiments of the present invention. In describing the preferred embodiments illustrated in the drawings, specific terminology is used for the sake of clarity. However, the invention is not intended to be limited to the specific terms that are selected. Rather, each specific term is intended to include all equivalents that operate in a similar or substantially similar manner to accomplish a similar or substantially similar result. Notably, the present invention can be implemented using software, hardware, or any combination thereof, as would be apparent to those of skill in the art.

Figure 2 shows a preferred embodiment of a system that can be used to conduct e-commerce transactions according to the present invention. A consumer 204, a merchant computer 208, and a billing computer 218 are all connected to computer network 202, which provides means for bi-directional communication between any two parties. One example of a suitable network is the Internet, which relies on TCP/IP protocols to communicate among a plurality of computers. The consumer 204 can connect to the computer network 202 using one of many technologies, such as a personal computer, a network-enabled television, a personal digital assistant, a cellular telephone with built-in computer connectivity such as a micro-browser, or similar technology known to those of skill in the art. Consumer 204 has an associated consumer identifier 206 that uniquely identifies the consumer while the consumer interacts with computer network 202. Consumer identifier 206 should be unique within computer network 202, at least from the time that a transaction is initiated through the time that a transaction is fulfilled.

Additionally, in a preferred embodiment, consumer identifier 206 is independent from the consumer's billing information that is provided to consumer billing authority 240. Such an embodiment allows consumer 204 to engage in transactions in such a way that merchant computer 208 does not receive information that identifies the consumer billing account.

In another preferred embodiment, consumer identifier 206 is anonymous, meaning that it identifies consumer 204 in a way that does not disclose personal information about the consumer. An anonymous consumer identifier contains information that enables merchant computer 208 to deliver a product or service to consumer 204, but does not otherwise identify consumer 204. Such an embodiment allows consumer 204 to engage in transactions anonymously.

Examples of preferred consumer identifiers include computer names, Internet Protocol (IP) addresses, browser identifiers, login identifiers along with domain names, identifiers that identify only the consumer's connection to computer network 202, digital certificates, distinguished names, and smart cards. Other types of consumer identifiers are known to those of skill in the art. As is conventional, most Internet service or network providers assign an IP address to consumers when they log in to the network; consequently, the IP address used by a particular consumer typically changes at each log-in.

One or more merchant computers 208 are connected to computer network 202. Figure 2 shows a single merchant computer 208 for illustrative purposes only. In the embodiment shown in Figure 2, merchant computer 208 includes a network interface 214 for communicating with computer network 202, a controller 210 for managing the operation and interaction of the modules within the computer and for executing the methods of the invention for conducting transactions. As shown in the embodiment depicted in Figure 2, merchant computer 208 can also include the following components: a comparator 212 for comparing values related to the processing of transactions such as consumer identifiers; a transaction memory 216 for storing information about transactions that are in progress or completed; and a predefined database 211 containing descriptions of predefined transactions. One skilled in the art will appreciate that merchant computer 208 can also include numerous conventional hardware and software components for providing information and products to consumers and for conducting transactions over computer network 202. Moreover, some or all of the modules shown in Figure 2 can be implemented with software, hardware, or both.

A billing computer 218 is configured to communicate with merchant computer 208 and consumer 204 through the computer network 202. In the embodiment shown in Figure 2, billing computer 218 includes a network interface 224 for connecting to and communicating with computer network 202; a consumer billing authority interface 230 for connecting to and communicating with a consumer billing authority 240 over a connection 242; and a controller 220 for managing the operation and interaction of the modules within the computer and for

executing the methods of the invention for conducting transactions. Connection 242 can include an automated or semi-automated connection via a computer network or dedicated computer link, or it can include a manual connection whereby communication requests are handled manually through human intervention.

5 As shown in the embodiment depicted in Figure 2, billing computer 208 can also include the following components: a comparator 222 for comparing values related to the approval of transactions such as consumer identifiers; an account database 232 for storing account information such as consumer account numbers, consumer billing account identifiers, or authorization codes for consumers that have registered with billing computer 218; a PIN
10 database 234 for storing information related to approving transactions, a predefined database 236 containing descriptions of predefined transactions; a transaction memory 226 for storing information about transactions that are in progress or completed; and an aggregation memory 228 for storing transactions that are in the process of being aggregated together into one or more billing events for submission to the consumer billing authority. One skilled in the art will
15 appreciate that billing computer 218 can also include numerous conventional hardware and software components for providing information and conducting transactions over computer network 202. Moreover, some or all of the modules shown in Figure 2 can be implemented with software, hardware, or both.

 As shown in the embodiment depicted in Figure 2, consumer billing authority 240 is a
20 system (e.g., a credit card payment processor) that is external to billing computer 208 and that:

- authorizes the charging of transactions to consumer billing accounts, as referenced by consumer billing account numbers and optionally other associated information;
- charges transactions to consumer billing accounts; and
- settles transactions charged to consumer billing accounts.

25 One skilled in the art will appreciate that consumer billing authority 240 can also include numerous conventional hardware and software components for providing the above functionality. Moreover, some or all of the modules shown in Figure 2 can be implemented with hardware, software, or both.

 The operation of the embodiment of the e-commerce system shown in Figure 2 will now
30 be described with reference to Figures 3 through 6. The system is used to conduct transactions between consumer 204, merchant computer 208, and billing computer 218, wherein consumer 204 intends to purchase a product or service from merchant computer 208 by charging the value of the product or service to a consumer billing account. Billing computer 218 will ultimately

charge the transaction to the consumer billing account, but such a charge can occur after the transaction is complete. Billing computer 218 can also aggregate the transaction with other transactions and charge the aggregated transactions to the consumer billing account, as will be discussed below. Significantly, the transaction is conducted without disclosure of information that identifies the consumer billing account to merchant computer 208. That is, neither
5 consumer 204 nor billing computer 218 transmits to merchant computer 208, and merchant computer 208 does not receive, information identifying the consumer billing account.

The overall method of conducting a transaction of the present invention can be broken down into four main steps, which are illustrated in Figures 3 through 6. The four main steps are:

- 10
- initiating a transaction (Figure 3);
 - authorizing the transaction (Figures 4A, 4B, and 4C);
 - approving the transaction (Figure 5); and
 - fulfilling the transaction (Figures 6A and 6B).

Each of the four main steps can be further broken down into one or more sub-steps. Although
15 the preferred embodiments described herein list particular combinations of sub-steps for each of the four main steps, the invention is not limited to those particular combinations of sub-steps. Rather, the invention includes within its scope the four main steps, and all possible combinations of the sub-steps that are described herein.

The four main steps, and the corresponding sub-steps that can be (but need not be) used
20 to carry out each of the four main steps, will now be described.

Figure 3 illustrates alternatives for the step of initiating a transaction. In one embodiment of the invention, consumer 204 initiates a transaction by transmitting an order 302 for a product or service to merchant computer 208. Merchant computer 208 can look up the order 302 in a predefined database 211 to retrieve a description of a predefined transaction that can
25 contain additional information about the order 302 (e.g., price, product code, etc.). Merchant computer 208 then transmits an order description 206, which contains information relating to the order, to billing computer 218.

Billing computer 218 then creates a transaction in its transaction memory 226, and returns to merchant computer 208 a transaction ID 308, which is a transaction identification code that can be used to reference the transaction again at a later time. Billing computer 218 can also
30 look up the order in a predefined database 236, which contains descriptions of predefined transactions, in order to retrieve additional information about the order. Information retrieved from predefined database 236 can be used in creating the transaction that is stored in transaction

memory 226. The transaction information that is stored in transaction memory 226 can contain information regarding the merchant corresponding to merchant computer 208, the product or service to be sold, the price of the transaction, restrictions associated with the product or service, and other related information.

5 After receiving transaction ID 308, merchant computer 208 can store transaction ID 308, as well as additional information about the transaction, in transaction memory 216. Finally, merchant computer 208 transmits transaction ID 308 to consumer 204.

10 In an alternative embodiment, consumer 204 initiates a transaction by transmitting an order 302 for a product or service to merchant computer 208. Merchant computer 208 can look up the order in a predefined database 211 to retrieve a description of a predefined transaction that can contain additional information about the order 302, such as a transaction ID 308. Merchant computer 208 can then store transaction ID 308, as well as additional information about the transaction, in transaction memory 216. Finally, merchant computer 208 transmits transaction ID 308 to consumer 204.

15 In an alternative embodiment, consumer 204 initiates a transaction by transmitting an order 302 for a product or service directly to billing computer 218. Billing computer 218 then creates a transaction in its transaction memory 226. Billing computer 218 can also look up the order in a predefined database 236, retrieve additional information about the order, and store the additional information in transaction memory 226.

20 Figure 4A illustrates alternatives for the step of authorizing a transaction. In one embodiment of the invention, billing computer 218 transmits a transaction description 402 to consumer 204. This step is optional, as consumer 204 can authorize the transaction corresponding to the previously placed order without feedback from billing computer 218.

25 If consumer 204 wishes to authorize the transaction, consumer 204 transmits an authorization code 404 to billing computer 218, containing billing information related to consumer 204. Authorization code 404 can also comprise authentication information, such as a digital certificate, a password, or a PIN code. Additionally, authorization code 404 can comprise the transaction ID 308 that corresponds to the transaction to be authorized, in which case billing computer 218 can use transaction ID 308 to look up the referenced transaction in transaction memory 226.

30 The billing information contained within authorization code 404 should identify, either directly or indirectly, the consumer billing account to which consumer 204 wishes to charge the transaction, so that billing computer 218 can later charge the transaction to that consumer billing

account through consumer billing authority 240. Accordingly, authorization code 404 can comprise a consumer billing account identifier (such as a consumer billing account number), a consumer account number that billing computer 218 looks up in account database 232 to retrieve a consumer billing account identifier, a digital certificate that contains embedded within it a consumer billing account identifier or a consumer account number, or a digital certificate that contains a reference to an external directory that can be consulted by billing computer 218 to obtain, either directly or indirectly, a billing account identifier.

In a preferred embodiment, authorization code 404 comprises the same consumer billing account number (such as a credit card number or a debit card number) that is submitted to consumer billing authority 240 to charge the transaction to the corresponding consumer billing account. In this way, consumer 204 can use the e-commerce system of the present invention to conduct transactions without needing to create or remember a new account number or some other identification number. For example, a pre-existing credit card or debit card can be used.

In a preferred embodiment, billing computer 218 uses authentication information contained within authorization code 404 to ensure that the consumer submitting authorization code 404 is in fact the consumer authorized to access the identified consumer billing account. Authentication information can comprise data known only to consumer 204, such as a password or PIN. Authentication information can also comprise the capture of a personal signature, a digital signature, biometric data, a digital certificate, or other types of authentication information, as known to those of skill in the art. Billing computer 218 can validate authentication information provided within authorization code 404 by referencing account database 232, PIN database 234, or an external directory.

In a preferred embodiment, authorization code 404 comprises a consumer billing account number and a password. Such an embodiment achieves the effect of transparently “adding” security to the consumer’s billing account by permitting the consumer to associate a personal password with the billing account. As one example, consumer 204 can pre-register with billing computer 218 by providing a PIN and credit card number that are to be used for future transactions.

The authentication information in authorization code 404 need not have a one-to-one correspondence with the underlying consumer billing account. A preferred embodiment of the present invention permits multiple PINs, each of which is associated with a separate consumer, to be associated with a single consumer billing account. In this way, transactions can be charged to a single consumer billing account by multiple consumers. For example, multiple family

members can charge transactions to a single credit card. In such an embodiment, billing computer 218 can use the authentication information to provide separate restrictions for different users of the consumer billing account. Restrictions can be directed to spending limits, credit limits, product-type limits, service-type limits, merchant-type limits, or merchant limits. Other types of restrictions can be determined by those of skill in the art. As an example, a parent can authorize a child to charge transactions to the parent's consumer billing account by creating a separate PIN for the child. The parent can then specify restrictions on the child's transactions, such as a credit limit restriction of \$20/month, or a type restriction on the types of products or services the child is permitted to purchase. The use of multiple PINs or other authentication codes to control transactions that are authorized by multiple users of a billing account is a feature of the present invention that can be used with a variety of systems and methods, and is not limited to use within the disclosed e-commerce system and methods.

In another embodiment of the present invention, consumer 204 can initiate and authorize a transaction by transmitting an order and an authorization code 404 to billing computer 218 substantially simultaneously. In yet another embodiment, consumer 204 can combine transmission of the order and transmission of the authorization code 404 into one transmission.

In an embodiment in which consumer 204, merchant computer 208, and billing computer 218 interact via the Internet, an embodiment of the authorization step can include display of transaction description 402 on a web page 450, as illustrated in Figure 4B. Consumer 204 can then enter an authorization code comprised of an account number, a PIN, and a zip code corresponding to the billing address for the consumer billing account in input boxes 460, 462, and 464, respectively. Consumer 204 can then select the Next button 470 to transmit the authorization code to billing computer 218. Billing computer 218 then verifies the authorization code and approves the transaction. If billing computer 218 approves the transaction, it displays transaction description 402 on a web page 452, as shown in Figure 4C, and gives consumer 204 one more chance to either accept or decline the transaction. Consumer 204 can complete authorization of the transaction by selecting the Accept button 472. Alternatively, consumer 204 can decline or cancel the transaction by selecting the Cancel button 474.

Figure 5 illustrates alternatives for the step of approving a transaction. In determining whether to approve a transaction, billing computer 218 considers the authorization code 404 provided by consumer 204. In alternative embodiments, billing computer 218 can also consider other information, such as the value of the product or service that consumer 204 wishes to purchase, or the balance of the consumer billing account to which the transaction is to be

charged. In an embodiment in which authorization code 404 comprises authentication information such as a PIN, billing computer 218 can further consider a spending or credit limit, or a product or service limit that can be associated with the authentication information.

5 In an alternative embodiment, billing computer 218 can transmit an authorization request 502 to consumer billing authority 240, requesting authorization to charge the consumer billing account. Authorization request 502 can include a consumer billing account identifier corresponding to the consumer billing account consumer 204 to which the consumer wishes to charge the transaction; the price of the product or service to be purchased; the nature of the product or service to be purchased; consumer billing account security or authentication information; or
10 other billing information related to consumer 204. Upon consideration of the authorization request 502, consumer billing authority 240 transmits an authorization response 504 back to billing computer 218 that either approves or denies the authorization request. Billing computer 218 can consider authorization response 504 in determining whether to approve the transaction. Consumer billing authority 240 can comprise a conventional computer that authorizes credit
15 card transactions.

After determining whether to approve the transaction, billing computer 218 transmits an approval 506 to merchant computer 208, indicating whether billing computer 218 has approved the transaction. In one embodiment, approval 506 comprises the transaction ID 308 corresponding to the transaction being conducted, which allows merchant computer 208 to correlate the
20 transaction to the consumer ID (but not the true identity of the consumer). Finally, in a preferred embodiment, billing computer 218 updates the information regarding the transaction in transaction memory 226.

If billing computer 218 approves the transaction, the transaction is then fulfilled. Figures 6A and 6B illustrate alternatives for the step of fulfilling a transaction. In the simplest
25 embodiment, merchant computer 208 transmits delivery fulfillment 610 to consumer 204, which comprises delivery of the product or service to consumer 204. The product or service can be delivered to consumer 204 by electronic transmission.

In an alternative embodiment, consumer 204 transmits a fulfillment request 602 to merchant computer 208. Consumer 204 can also transmit consumer identifier 206 to merchant
30 computer 208; this consumer identifier can be transmitted separately, or it can be transmitted as part of fulfillment request 602. Consumer 204 can also transmit consumer identifier 206 to billing computer 218; this consumer identifier can be transmitted separately, or it can be transmitted as part of authorization code 404. Billing computer 218 can then transmit consumer

identifier 206 to merchant computer 208; this consumer identifier can be transmitted separately, or it can be transmitted as part of approval 506.

Merchant computer 208 then determines whether to fulfill the fulfillment request 602. In making that determination, merchant computer 208 can consider any of the information it has received regarding the transaction, as well as any information about the transaction it has stored in transaction memory 216. Merchant computer 208 can also use comparator 212 to compare the consumer identifier 206 transmitted by consumer 204 to merchant computer 208, and the consumer identifier 206 transmitted by consumer 204 to billing computer 218 and forwarded by billing computer 218 to merchant computer 208. If the two consumer identifiers match, and merchant computer 208 determines to fulfill the fulfillment request 602, merchant computer 208 then transmits delivery fulfillment 610 to consumer 204.

In an alternative embodiment, consumer 204 transmits a fulfillment request 602 to merchant computer 208. Consumer 204 can also transmit consumer identifier 206 to merchant computer 208; this consumer identifier can be transmitted separately, or it can be transmitted as part of fulfillment request 602. Consumer 204 can also transmit consumer identifier 206 to billing computer 218; this consumer identifier can be transmitted separately, or it can be transmitted as part of authorization code 404.

Merchant computer 208 then transmits a fulfillment approval request 606 to billing computer 218. Merchant computer 208 can also transmit consumer identifier 206 to billing computer 218; this consumer identifier can be transmitted separately, or it can be transmitted as part of fulfillment approval request 606.

Billing computer 218 then determines whether to approve the fulfillment approval request 606. In making that determination, billing computer 218 can consider any of the information it has received regarding the transaction, as well as any information about the transaction it has stored in transaction memory 226. Billing computer 218 can also use comparator 222 to compare the consumer identifier 206 transmitted by consumer 204 to billing computer 218, and the consumer identifier 206 transmitted by consumer 204 to merchant computer 208 and forwarded by merchant computer 208 to billing computer 218. If the two consumer identifiers match, and billing computer 218 determines to approve the fulfillment approval request 606, billing computer 218 transmits a fulfillment approval response 608 to merchant computer 208 that indicates approval to fulfill the transaction. Otherwise, billing computer 218 transmits a fulfillment approval response 608 to merchant computer 208 that indicates denial to fulfill the transaction. Finally, if fulfillment approval response 608 indicates

approval to fulfill the transaction, merchant computer 208 transmits delivery fulfillment 610 to consumer 204.

In yet another embodiment, consumer 204 transmits a fulfillment request 602 to merchant computer 208. Consumer 204 can also transmit consumer identifier 206 to merchant
5 computer 208; this consumer identifier can be transmitted separately, or it can be transmitted as part of fulfillment request 602. Consumer 204 can also transmit consumer identifier 206 to billing computer 218; this consumer identifier can be transmitted separately, or it can be transmitted as part of authorization code 404.

Merchant computer 208 then transmits a fulfillment approval request 606 to billing com-
10 puter 218. Merchant computer 208 can also transmit consumer identifier 206 to billing computer 218; this consumer identifier can be transmitted separately, or it can be transmitted as part of fulfillment approval request 606.

Billing computer 218 then determines whether to approve the fulfillment approval re-
quest 606. In making that determination, billing computer 218 can consider any of the
15 information it has received regarding the transaction, as well as any information about the transaction it has stored in transaction memory 226. If billing computer 218 determines to approve the fulfillment approval request 606, billing computer 218 transmits a fulfillment approval response 608 to merchant computer 208 that indicates approval to fulfill the transaction. Otherwise, billing computer 218 transmits a fulfillment approval response 608 to merchant
20 computer 208 that indicates denial to fulfill the transaction. Billing computer 218 can also transmit the consumer identifier 206 that it received from consumer 204 to merchant computer 208; this consumer identifier can be transmitted separately, or it can be transmitted as part of fulfillment approval response 608.

Merchant computer 208 then determines whether to fulfill the fulfillment request 602. In
25 making that determination, merchant computer 208 can consider any of the information it has received regarding the transaction, as well as any information about the transaction it has stored in transaction memory 216. Merchant computer 208 can also consider fulfillment approval response 608. Merchant computer 208 can also use comparator 212 to compare the consumer identifier 206 transmitted by consumer 204 to merchant computer 208, and the consumer
30 identifier 206 transmitted by consumer 204 to billing computer 218 and forwarded by billing computer 218 to merchant computer 208. If the two consumer identifiers match, and merchant computer 208 determines to fulfill the fulfillment request 602, merchant computer 208 then transmits delivery fulfillment 610 to consumer 204.

As part of fulfilling the transaction, billing computer 218 can charge the transaction to the consumer billing account. In one embodiment, billing computer 218 transmits charge submission 614 to consumer billing authority 240, as shown in Figure 6B. Consumer billing authority 240 then transmits charge response 616 to billing computer 218. Charge response 616 can indicate the status of the charge, including whether the charge succeeded or failed.

In another embodiment, charge submission 614 can be conducted in conjunction with authorization request 502, so as to ensure the success of the charge. In such an embodiment, billing computer 218 can store the information required to coordinate authorization request 502 and charge submission 614 in transaction memory 226.

In an alternative embodiment, merchant computer 208 transmits delivery acknowledgment 612 to billing computer 218. Delivery acknowledgment 612 indicates the status of the delivery of the product or service. Billing computer 218 then transmits charge submission 614 to consumer billing authority 240 only if delivery acknowledgment 612 indicates that fulfillment delivery 610 to consumer 204 has been completed. This embodiment has the advantage of ensuring that the product or service is delivered to consumer 204 successfully before the transaction is charged to the consumer billing authority 240.

In an alternative embodiment, the system and methods of the present invention are used to conduct multiple transactions between a consumer 204 and one or more merchant computers 208. In such an embodiment, billing computer 218 need not charge each individual transaction to the consumer billing account. Billing computer 218 can instead aggregate two or more transactions, and charge the aggregated transactions to the consumer billing account.

More specifically, billing computer 218 can store some completed transactions in an aggregation memory 228. Note that billing computer 218 can receive a delivery acknowledgment for all, some, or none of the completed transactions. Billing computer 218 can then aggregate the completed transactions into a single billing event for submission to consumer billing authority 240. In other words, billing computer 218 can aggregate the completed transactions and submit them to consumer billing authority 240 via one charge submission 614. In that way, the aggregated transactions are charged to the consumer billing account as one billing event. In an alternative embodiment, billing computer 218 can aggregate completed transactions into more than one billing event for submission to consumer billing authority 240.

Billing computer 218 can charge aggregated transactions to a consumer billing account upon the occurrence of a specified event. In one embodiment, billing computer 218 charges the aggregated transactions when the number of aggregated transactions exceeds a predetermined

number threshold. In another embodiment, billing computer 218 charges the aggregated transactions when a predetermined period of time expires. In yet another embodiment, billing computer 218 charges the aggregated transactions when the sum of the aggregated transactions (i.e., the sum total of the amounts of the aggregated transactions) exceeds a predetermined amount threshold. Other suitable triggering events for submitting aggregated transactions to consumer billing authority 240 can be determined by those of skill in the art. The triggering event is preferably chosen such that it is profitable for billing computer 218 to charge the aggregated transactions to the consumer billing account, in light of the processing fees that are charged by consumer billing authority 240 and other payment processing firms and financial institutions.

In an alternative embodiment, billing computer 218 can use predetermined criteria to determine whether each transaction is to be charged directly to the consumer billing account, or aggregated with other transactions and charged to the consumer billing account as an aggregate total. In one embodiment, the predetermined criteria comprises a pass-through threshold amount. In such an embodiment, transactions above the pass-through threshold amount are charged to the consumer billing account individually, whereas transactions below the pass-through threshold amount are aggregated and charged to the consumer billing account as an aggregate total. For example, in an embodiment in which the pass-through threshold amount is set to \$8, a \$20 charge incurred for downloading a software program would be charged to the consumer billing account directly, while a \$0.25 charge incurred for downloading a picture would be aggregated with other microtransactions and submitted as part of an aggregate charge at a later time. In another embodiment, the predetermined criteria for determining whether to aggregate a transaction comprises the type of the transaction. Other suitable criteria for determining whether to aggregate a transaction can be determined by those of skill in the art. Suitable triggering events for charging the aggregated transactions to the consumer billing account can also be determined by those of skill in the art.

In an alternative embodiment, billing computer 218 can obtain a pre-authorization from the consumer billing authority that permits charging a predetermined amount to the consumer billing account. Such a pre-authorization can be used to ensure that the consumer billing account can accommodate the charging of aggregated transactions. Billing computer 218 can obtain a pre-authorization by transmitting an authorization request 502 to consumer billing authority 240, and receiving an authorization response 504 in response.

In one embodiment, billing computer 218 obtains pre-authorization as part of the approval step of conducting a transaction. In alternative embodiments, billing computer 218 can obtain pre-authorization when the consumer registers with the billing computer, when a predetermined period of time passes after the previous pre-authorization, or when the sum of a number of aggregated transactions exceeds a predetermined amount. Other suitable triggering events for obtaining a pre-authorization can be determined by those of skill in the art.

Aggregation and pre-authorization, used either independently or in conjunction, are features of the present invention that can be used with a variety of systems and methods, and are not limited to use within the disclosed e-commerce system and methods.

Although the system and methods of the present invention have been described from an overall perspective, the invention is not directed solely to the overall system and the overall methods. Rather, the invention includes within its scope the independent merchant computer and billing computer portions of the system, as well as the corresponding portions of the methods that are executed at the merchant computer and at the billing computer.

Moreover, although the invention has been particularly described by reference to specific embodiments, it should be readily apparent to those of ordinary skill in the art that various changes and modifications can be made in form and details without departing from the spirit and scope of the invention. The appended claims are intended to cover such changes and modifications, so as to afford broad protection to the invention and its equivalents.

The steps of the method claims need not be practiced in the specific order listed, and such ordering should not be interpreted as limiting the scope of the invention.

CLAIMS

What is claimed is:

1. A method of conducting a transaction between a consumer, a merchant computer, and a billing computer connected together over a computer network, wherein the consumer purchases a product or service from the merchant computer by charging the value of the product or service to a consumer billing account, the method comprising the steps of:
 - (1) initiating the transaction for the product or service;
 - (2) the consumer authorizing the transaction by transmitting an authorization code to the billing computer;
 - (3) the billing computer determining whether to approve the transaction by considering the authorization code; and
 - (4) fulfilling the transaction if the billing computer approves the transaction;wherein the merchant computer does not receive information identifying the consumer billing account.
2. The method of claim 1, wherein step (1) comprises the steps of:
 - (a) transmitting from the consumer to the merchant computer an order for the product or service;
 - (b) transmitting from the merchant computer to the billing computer information relating to the order;
 - (c) transmitting from the billing computer to the merchant computer a transaction identification code; and
 - (d) transmitting from the merchant computer to the consumer the transaction identification code.
3. The method of claim 1, wherein step (1) comprises the steps of:
 - (a) transmitting from the consumer to the merchant an order for the product or service; and
 - (b) transmitting from the merchant computer to the consumer a transaction identification code.

4. The method of claim 1, wherein step (1) comprises the step of transmitting from the consumer to the billing computer an order for the product or service.
5. The method of claim 4, wherein steps (1) and (2) are combined into one transmission.
6. The method of claim 1, further comprising, prior to step (2), the step of transmitting from the billing computer to the consumer a description of the transaction.
7. The method of claim 1, wherein step (3) comprises the steps of:
 - 10 (a) transmitting an authorization request to a consumer billing authority; and
 - (b) receiving an authorization response from the consumer billing authority.
8. The method of claim 1, wherein the authorization code comprises a billing account identifier.
15. The method of claim 8, wherein the authorization code further comprises a PIN.
10. The method of claim 9, wherein:
 - 20 the PIN is associated with a predetermined restriction for the consumer; and
 - wherein step (3) includes the step of considering the predetermined restriction.
11. The method of claim 1, wherein step (4) comprises the step of delivering the product or service to the consumer.
25. The method of claim 11, wherein step (4) further comprises the step of transmitting from the merchant computer to the billing computer an acknowledgment of the delivery of the product or service indicating the status of the delivery.
30. The method of claim 12, further comprising the step of charging the transaction to the consumer billing account only if the delivery acknowledgment indicates that the delivery of the product or service was successful.

14. The method of claim 1, wherein step (4) comprises the steps of:
- (a) transmitting from the consumer to the billing computer a first consumer identifier;
 - (b) transmitting from the billing computer to the merchant computer the first consumer identifier;
 - 5 (c) transmitting from the consumer to the merchant computer an order fulfillment request and a second consumer identifier;
 - (d) comparing the first consumer identifier and the second consumer identifier; and
 - (e) delivering the product or service to the consumer if the first consumer identifier matches the second consumer identifier.
- 10
15. The method of claim 1, wherein step (4) comprises the steps of:
- (a) transmitting from the consumer to the billing computer a first consumer identifier;
 - (b) transmitting from the consumer to the merchant computer an order fulfillment request and a second consumer identifier;
 - 15 (c) transmitting from the merchant computer to the billing computer a fulfillment approval request and the second consumer identifier;
 - (d) comparing the first consumer identifier and the second consumer identifier;
 - (e) if the first consumer identifier matches the second consumer identifier, transmitting from the billing computer to the merchant computer a fulfillment approval response indicating approval to fulfill the transaction, and otherwise transmitting a fulfillment approval response indicating denial to fulfill the transaction; and
 - 20 (f) delivering the product or service to the consumer if the fulfillment approval response indicates approval to fulfill the transaction.
- 25
16. The method of claim 0 or 15, wherein the first consumer identifier and the second consumer identifier identify only the consumer's connection to the computer network.
17. The method of claim 0 or 15, wherein the first consumer identifier and the second consumer identifier comprise a digital certificate.
- 30
18. A method of conducting a transaction between a consumer, a merchant computer, and a billing computer connected together over a computer network, wherein the consumer pur-

chases a product or service from the merchant computer by charging the value of the product or service to a consumer billing account, the method comprising the steps of:

(1) transmitting from the consumer to the merchant computer an order for the product or service;

5 (2) transmitting from the merchant computer to the billing computer information relating to the order;

(3) transmitting from the billing computer to the merchant computer a transaction identification code;

10 (4) transmitting from the merchant computer to the consumer the transaction identification code;

(5) transmitting from the billing computer to the consumer a description of the transaction;

15 (6) transmitting from the consumer to the billing computer an authorization code for the transaction comprising a billing account identifier and a first consumer identifier;

(7) the billing computer determining whether to approve the transaction by considering the authorization code;

(8) transmitting from the billing computer to the merchant computer the first consumer identifier;

20 (9) transmitting from the consumer to the merchant computer an order fulfillment request and a second consumer identifier;

(10) comparing the first consumer identifier and the second consumer identifier; and

25 (11) delivering the product from the merchant computer to the consumer if the billing computer approves the transaction and the first consumer identifier matches the second consumer identifier; and

wherein the merchant computer does not receive information identifying the consumer billing account.

30 19. A method of conducting a transaction between a consumer, a merchant computer, and a billing computer connected together over a computer network, wherein the consumer purchases a product or service from the merchant computer by charging the value of the product or service to a consumer billing account, the method comprising the steps of:

- (1) transmitting from the consumer to the merchant computer an order for the product or service;
- (2) transmitting from the merchant computer to the billing computer information relating to the order;
- 5 (3) transmitting from the billing computer to the merchant computer a transaction identification code;
- (4) transmitting from the merchant computer to the consumer the transaction identification code;
- (5) transmitting from the billing computer to the consumer a description of the trans-
10 action;
- (6) transmitting from the consumer to the billing computer an authorization code for the transaction comprising a billing account identifier and a first consumer identifier;
- (7) the billing computer determining whether to approve the transaction by consider-
15 ing the authorization code;
- (8) transmitting from the consumer to the merchant computer an order fulfillment request and a second consumer identifier;
- (9) transmitting from the merchant computer to the billing computer a fulfillment approval request and the second consumer identifier;
- 20 (10) comparing the first consumer identifier and the second consumer identifier;
- (11) transmitting from the billing computer to the merchant computer a fulfillment approval response indicating approval to fulfill the transaction if the first consumer identifier matches the second consumer identifier, and denial to fulfill the transaction otherwise; and
- 25 (12) delivering the product or service to the consumer if the billing computer approves the transaction and the fulfillment approval response indicates approval to fulfill the transaction; and

wherein the merchant computer does not receive information identifying the consumer billing account.

- 30 20. A method of conducting a multiplicity of transactions between a consumer, at least one merchant computer, and a billing computer connected together over a computer network, wherein each transaction is for a product or service that the consumer purchases from one

of the at least one merchant computer, the method comprising the step of conducting each transaction according to the method of claims 1, 18, or 19.

21. The method of claim 20, further comprising the steps of:

5 aggregating the multiplicity of transactions; and
charging the aggregated multiplicity of transactions to the consumer billing account
upon the occurrence of a specified event.

22. The method of claim 20, further comprising the steps of:

10 charging those of the multiplicity of transactions that meet predetermined criteria to
the consumer billing account;
aggregating those of the multiplicity of transactions that do not meet the predeter-
mined criteria; and
charging the aggregated transactions to the consumer billing account only upon the
15 occurrence of a specified event.

23. The method of claim 20, further comprising the steps of:

obtaining from the consumer billing authority a pre-authorization that permits charg-
ing a predetermined amount to the consumer billing account;
20 aggregating the multiplicity of transactions; and
charging the aggregated transactions to the consumer billing account upon the occur-
rence of a specified event.

24. The method of claim 20, further comprising the steps of:

25 obtaining from the consumer billing authority a pre-authorization that permits charg-
ing a predetermined amount to the consumer billing account;
charging those of the multiplicity of transactions that meet predetermined criteria to
the consumer billing account;
aggregating those of the multiplicity of transactions that do not meet the predeter-
30 mined criteria; and
charging the aggregated transactions to the consumer billing account upon the occur-
rence of a specified event.

25. A method of conducting a transaction at a merchant computer connected by a computer network to a consumer and a billing computer, wherein the consumer purchases a product or service from the merchant computer by charging the value of the product or service to a consumer billing account, the method comprising the steps of:
- 5 (1) initiating the transaction for the product or service;
- (2) receiving an approval indication for the transaction from the billing computer;
- and
- (3) fulfilling the transaction if the billing computer approves the transaction; and
- wherein the merchant computer does not receive information identifying the consumer
- 10 billing account.
26. The method of claim 25, wherein step (1) comprises the steps of:
- (a) receiving an order for the product or service from the consumer;
- (b) transmitting information relating to the order to the billing computer;
- 15 (c) receiving a transaction identification code from the billing computer; and
- (d) transmitting the transaction identification code to the consumer.
27. The method of claim 25, wherein step (1) comprises the steps of:
- (a) receiving an order for the product or service from the consumer; and
- 20 (b) transmitting a transaction identification code to the consumer.
28. The method of claim 25, wherein step (3) comprises the step of delivering the product or service to the consumer.
- 25 29. The method of claim 28, wherein step (3) further comprises the step of transmitting to the billing computer an acknowledgment of the delivery of the product or service indicating the status of the delivery.
- 30 30. The method of claim 25, wherein step (3) comprises the steps of:
- (a) receiving a first consumer identifier from the billing computer;
- (b) receiving an order fulfillment request and a second consumer identifier from the consumer;
- (c) comparing the first consumer identifier and the second consumer identifier; and

(d) delivering the product or service to the consumer only if the first consumer identifier matches the second consumer identifier.

31. The method of claim 25, wherein step (3) comprises the steps of:

- 5 (a) receiving an order fulfillment request and a consumer identifier from the consumer;
- (b) transmitting to the billing computer a fulfillment approval request and the consumer identifier;
- (c) receiving a fulfillment approval response from the billing computer; and
- 10 (d) delivering the product or service to the consumer if the fulfillment approval response indicates approval to fulfill the transaction.

32. A method of conducting a transaction at a merchant computer connected by a computer network to a consumer and a billing computer, wherein the consumer purchases a product or service from the merchant computer by charging the value of the product or service to a consumer billing account, the method comprising the steps of:

- 15 (1) receiving an approval indication for the transaction from the billing computer;
- (2) fulfilling the transaction if the billing computer approves the transaction; and
- wherein the merchant computer does not receive information identifying the consumer billing account.
- 20

33. A method of conducting a transaction at a merchant computer connected by a computer network to a consumer and a billing computer, wherein the consumer purchases a product or service from the merchant computer by charging the value of the product or service to a consumer billing account, the method comprising the steps of:

- 25 (1) receiving an order for the product or service from the consumer;
- (2) transmitting information relating to the order to the billing computer;
- (3) receiving a transaction identification code from the billing computer;
- (4) transmitting the transaction identification code to the consumer;
- 30 (5) receiving an approval indication for the transaction and a first consumer identifier from the billing computer;
- (6) receiving an order fulfillment request and a second consumer identifier from the consumer;

- (7) comparing the first consumer identifier and the second consumer identifier; and
- (8) delivering the product to the consumer if the billing computer approves the transaction and the first consumer identifier matches the second consumer identifier; and

5 wherein the merchant computer does not receive information identifying the consumer billing account.

34. A method of conducting a transaction at a merchant computer connected by a computer network to a consumer and a billing computer, wherein the consumer wishes to purchase a product or service from the merchant computer by charging the value of the product or service to a consumer billing account, the method comprising the steps of:

- (1) receiving an order for the product or service from the consumer;
- (2) transmitting information relating to the order to the billing computer;
- (3) receiving a transaction identification code from the billing computer;
- 15 (4) transmitting the transaction identification code to the consumer;
- (5) receiving an approval indication for the transaction from the billing computer;
- (6) receiving an order fulfillment request and a consumer identifier from the consumer;
- (7) transmitting a fulfillment approval request and the consumer identifier to the billing computer;
- 20 (8) receiving a fulfillment approval response from the billing computer;
- (9) delivering the product or service to the consumer if the billing computer approves the transaction and the fulfillment approval response indicates approval to fulfill the transaction; and

25 wherein the merchant computer does not receive information identifying the consumer billing account.

35. A merchant computer connected by a computer network to a consumer and a billing computer, comprising:

- 30 a network interface for connecting to the computer network; and
- a controller for conducting a transaction with the consumer, wherein the controller conducts the transaction with the consumer upon receiving an approval code from the billing computer,

wherein the merchant computer does not receive information identifying the consumer billing account.

- 5 36. The merchant computer of claim 35, further comprising a transaction memory for storing transaction information from the billing computer.
- 10 37. The merchant computer of claim 35, further comprising a comparator for comparing consumer identifiers one received from the consumer and a second one received from the billing computer.
- 15 38. The merchant computer of claim 35, wherein the controller performs the steps of:
(1) initiating the transaction for the product or service;
(2) receiving an approval indication for the transaction from the billing computer;
and
(3) fulfilling the transaction if the billing computer approves the transaction.
- 20 39. The merchant computer of claim 36, wherein the controller performs the steps of:
(1) initiating the transaction for the product or service;
(2) storing information about the transaction in the transaction memory;
(3) receiving an approval indication for the transaction from the billing computer;
(4) storing the approval in the transaction memory; and
(5) fulfilling the transaction if the billing computer approves the transaction.
- 25 40. The merchant computer of claim 37, wherein the controller performs the steps of:
(1) initiating the transaction for the product or service;
(2) receiving an approval indication for the transaction from the billing computer;
(3) receiving a first consumer identifier from the billing computer;
(4) receiving an order fulfillment request and a second consumer identifier from the
consumer;
30 (5) comparing the first consumer identifier and the second consumer identifier using
the comparator; and

(6) delivering the product or service to the consumer if the billing computer approves the transaction and the first consumer identifier matches the second consumer identifier.

5 41. A method of conducting a transaction at a billing computer connected to a computer network, wherein a consumer purchases a product or service from a merchant computer by charging the value of the product or service to a consumer billing account, the method comprising the steps of:

- 10 (1) initiating the transaction for the product or service;
- (2) receiving an authorization code from the consumer indicating authorization to conduct the transaction;
- (3) determining whether to approve the transaction by considering the authorization code;
- 15 (4) transmitting approval to conduct the transaction to the merchant computer if the transaction is approved;
- (5) fulfilling the transaction if the transaction is approved; and
- wherein the billing computer does not transmit information identifying the consumer billing account to the merchant computer.

20 42. The method of claim 41, wherein step (1) comprises the steps of:

(a) receiving from the merchant computer information relating to an order for the product or service placed by the consumer; and

(b) transmitting to the merchant computer a transaction identification code.

25 43. The method of claim 41, wherein step (1) comprises the step of receiving an order for the product or service from the consumer.

44. The method of claim 43, wherein steps (1) and (2) occur substantially simultaneously.

30 45. The method of claim 41, further comprising, prior to step (2), the step of transmitting to the consumer a description of the transaction.

46. The method of claim 41, wherein step (3) comprises the steps of:
 (a) transmitting an authorization request to the consumer billing authority; and
 (b) receiving an authorization response from the consumer billing authority.
- 5 47. The method of claim 41, wherein the authorization code comprises a billing account identifier.
48. The method of claim 47, wherein the authorization code further comprises a PIN.
- 10 49. The method of claim 48, wherein:
 the PIN is associated with a predetermined restriction for the consumer; and
 the step of determining whether to approve the transaction further includes considering the predetermined restriction.
- 15 50. The method of claim 41, wherein step (5) comprises the step of receiving from the merchant computer an acknowledgment that the merchant computer delivered the product or service to the consumer and indicating the status of the delivery.
- 20 51. The method of claim 50, further comprising the step of charging the transaction to the consumer billing account only if the delivery acknowledgment indicates that the delivery of the product or service was successful.
- 25 52. The method of claim 41, wherein step (5) comprises the steps of:
 (a) receiving a consumer identifier from the consumer; and
 (b) transmitting the consumer identifier to the merchant computer.
- 30 53. The method of claim 41, wherein step (5) comprises the steps of:
 (a) receiving from the consumer a first consumer identifier;
 (b) receiving from the merchant computer a fulfillment approval request and a second consumer identifier;
 (c) comparing the first consumer identifier and the second consumer identifier; and
 (d) if the first consumer identifier matches the second consumer identifier, transmitting to the merchant computer a fulfillment approval response indicating ap-

proval to fulfill the transaction, and otherwise transmitting a fulfillment approval response indicating denial to fulfill the transaction.

54. A method of conducting a transaction at a billing computer connected to a computer network, wherein a consumer purchases a product or service from a merchant computer by charging the value of the product or service to a consumer billing account, the method comprising the steps of:

(1) receiving an authorization code from the consumer indicating authorization to conduct the transaction;

(2) determining whether to approve the transaction by considering the authorization code;

(3) transmitting approval to conduct the transaction to the merchant computer if the transaction is approved;

(4) fulfilling the transaction if the transaction is approved; and

wherein the billing computer does not transmit information identifying the consumer billing account to the merchant computer.

55. A method of conducting a transaction at a billing computer connected to a computer network, wherein a consumer purchases a product or service from a merchant computer by charging the value of the product or service to a consumer billing account, the method comprising the steps of:

(1) receiving from the merchant computer information relating to an order for the product or service placed by the consumer;

(2) transmitting to the merchant computer a transaction identification code;

(3) transmitting to the consumer a description of the transaction;

(4) receiving from the consumer an authorization code for the transaction comprising a billing account identifier and a consumer identifier;

(5) determining whether to approve the transaction by considering the authorization code;

(6) transmitting approval to conduct the transaction to the merchant computer if the transaction is approved;

(7) transmitting to the merchant computer the consumer identifier; and

wherein the billing computer does not transmit information identifying the consumer billing account to the merchant computer.

56. A method of conducting a transaction at a billing computer connected to a computer network, wherein a consumer purchases a product or service from a merchant computer by charging the value of the product or service to a consumer billing account, the method comprising the steps of:

(1) receiving from the merchant computer information relating to an order for the product or service placed by the consumer;

(2) transmitting to the merchant computer a transaction identification code;

(3) transmitting to the consumer a description of the transaction;

(4) receiving from the consumer an authorization code for the transaction comprising a billing account identifier and a first consumer identifier;

(5) determining whether to approve the transaction by considering the authorization code;

(6) transmitting approval to conduct the transaction to the merchant computer if the transaction is approved;

(7) receiving from the merchant computer a fulfillment approval request and a second consumer identifier;

(8) comparing the first consumer identifier and the second consumer identifier;

(9) transmitting to the merchant computer a fulfillment approval response indicating approval to fulfill the transaction if the first consumer identifier matches the second consumer identifier, and denial to fulfill the transaction otherwise; and

wherein the billing computer does not transmit information identifying the consumer billing account to the merchant computer.

57. A method of conducting a multiplicity of transactions between a consumer and at least one merchant computer at a billing computer, wherein:

the consumer, the at least one merchant computer, and the billing computer are connected together over a computer network;

each transaction is for a product or service that the consumer purchases from at least one merchant computer; and

the method comprises the step of conducting each of the multiplicity of transactions according to the method of claims 41, 55, or 56.

58. The method of claim 57, further comprising the steps of:

5 aggregating the multiplicity of transactions; and
charging the aggregated multiplicity of transactions to the consumer billing account upon the occurrence of a specified event.

59. The method of claim 57, further comprising the steps of:

10 charging those of the multiplicity of transactions that meet predetermined criteria to the consumer billing account;
aggregating those of the multiplicity of transactions that do not meet the predetermined criteria; and
15 charging the aggregated transactions to the consumer billing account upon the occurrence of a specified event.

60. The method of claim 57, further comprising the steps of:

obtaining from the consumer billing authority a pre-authorization that permits charging a predetermined amount to the consumer billing account;
20 aggregating the multiplicity of transactions;
charging the aggregated transactions to the consumer billing account upon the occurrence of a specified event.

61. The method of claim 57, further comprising the steps of:

25 obtaining from the consumer billing authority a pre-authorization that permits charging a predetermined amount to the consumer billing account;
charging those of the multiplicity of transactions that meet predetermined criteria to the consumer billing account;
aggregating those of the multiplicity of transactions that do not meet the predetermined criteria; and
30 charging the aggregated transactions to the consumer billing account upon the occurrence of a specified event.

62. A billing computer connected to a consumer and a merchant computer by a computer network, comprising:

a network interface for connecting to the computer network;

a consumer billing authority interface for connecting to a consumer billing authority;

5 a transaction memory for storing transaction information;

an account database for storing consumer account information;

a comparator for determining whether to approve transactions;

a controller for conducting a transaction including the purchased of a product or service by charging the value of the product or service to a consumer billing account; and

10

wherein the billing computer does not transmit information identifying the consumer billing account to the merchant computer and does not receive information identifying the consumer billing account from the merchant computer.

15 63. The billing computer of claim 62, further comprising a predefined database containing predefined transaction descriptions.

64. The billing computer of claim 62, further comprising an aggregation memory for storing previously completed transactions that are to be aggregated together into one or more billing events for submission to the consumer billing authority.

20

65. The billing computer of claim 62, wherein the controller performs the steps of:

(1) initiating the transaction for the product or service;

(2) storing information about the transaction in the transaction memory;

25 (3) receiving an authorization code from the consumer indicating authorization to conduct the transaction;

(4) determining whether to approve the transaction using the computer by considering the authorization code and the consumer account information in the account database; and

30 (5) if the transaction is approved, performing the further steps of:

(6) transmitting approval to conduct the transaction to the merchant computer;

(7) fulfilling the transaction; and

(8) communicating with the consumer billing authority to charge the transaction to the consumer billing account.

66. The billing computer of claim 63, wherein the controller performs the steps of:

- 5 (1) initiating the transaction for the product or service based upon a predefined transaction description in the predefined database;
- (2) storing information about the transaction in the transaction memory;
- (3) receiving an authorization code from the consumer indicating authorization to conduct the transaction;
- 10 (4) determining whether to approve the transaction by considering the authorization code and the consumer account information in the account database; and
- (5) if the transaction is approved, performing the further steps of:
- (6) transmitting approval to conduct the transaction to the merchant computer;
- (7) fulfilling the transaction; and
- 15 (8) communicating with the consumer billing authority to charge the transaction to the consumer billing account.

67. The billing computer of claim 64, wherein the controller performs the steps of:

- (1) initiating the transaction for the product or service;
- 20 (2) storing information about the transaction in the transaction memory;
- (3) receiving an authorization code from the consumer indicating authorization to conduct the transaction;
- (4) determining whether to approve the transaction by considering the authorization code and the consumer account information in the account database;
- 25 (5) if the transaction is approved, performing the steps of:
- (a) transmitting approval to conduct the transaction to the merchant computer;
- and
- (b) fulfilling the transaction; and

wherein the controller performs the further steps of:

- (6) storing the transaction in the aggregation memory;
- (7) aggregating into an aggregate total the transaction with one or more previously
5 completed transactions stored in the aggregation memory; and
- (8) communicating with the consumer billing authority to charge the aggregate total
to the consumer billing account as one or more billing events.

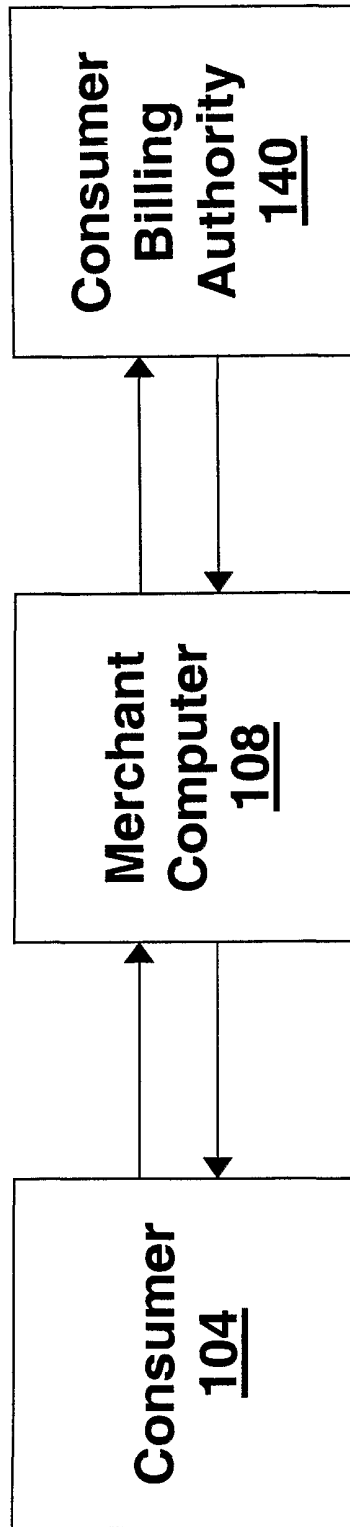

FIGURE 1
(PRIOR ART)

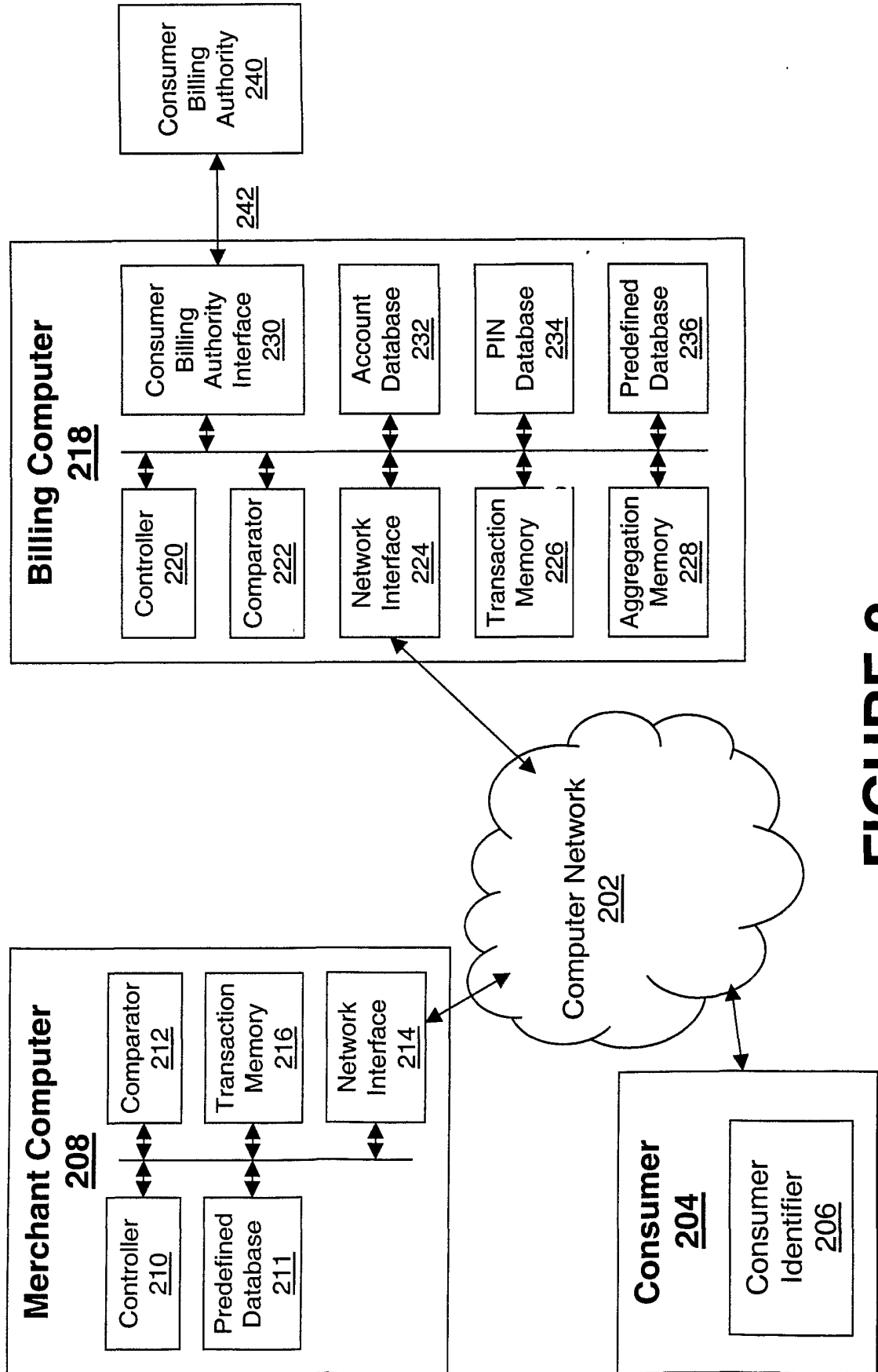

FIGURE 2

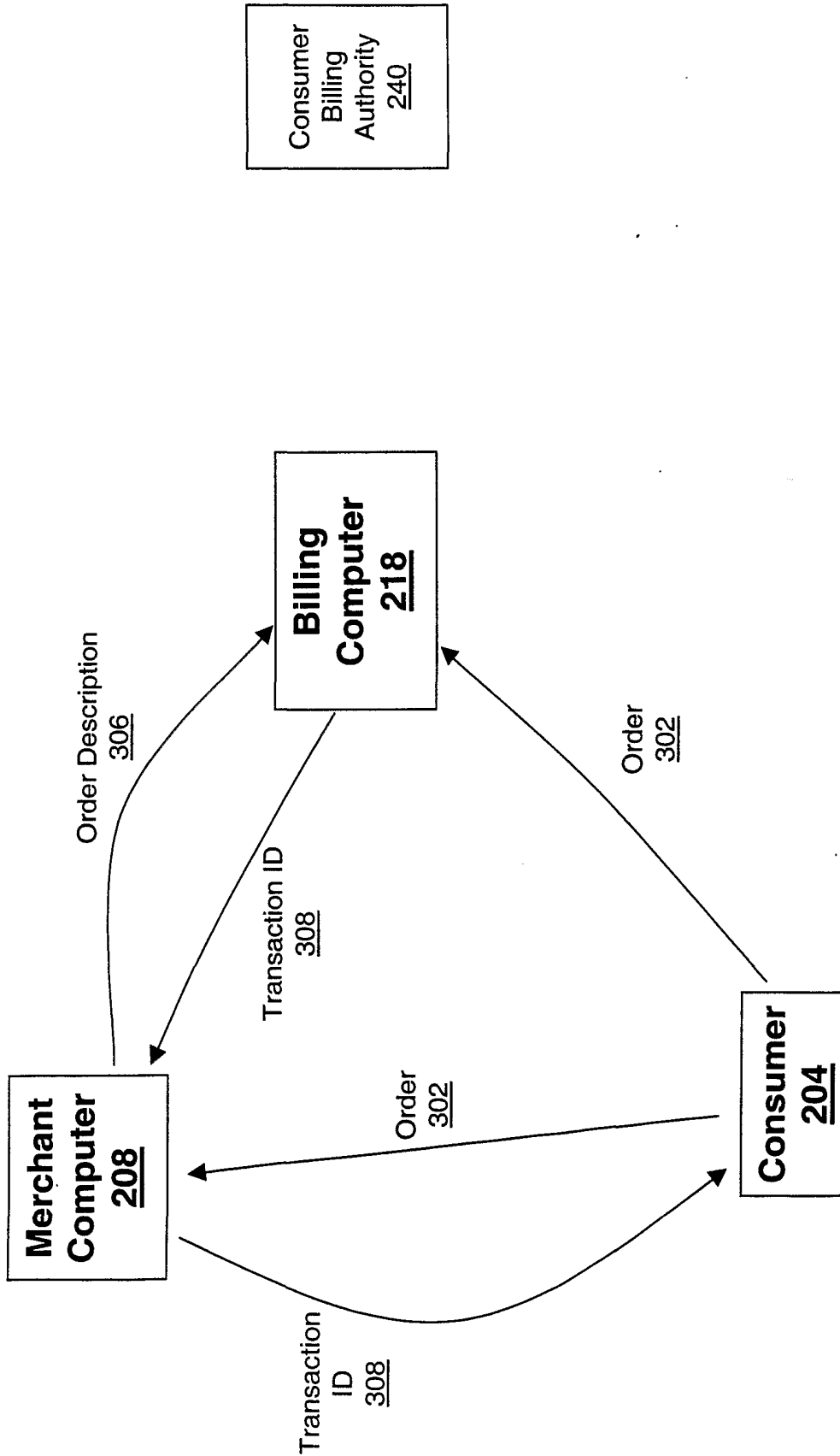

FIGURE 3

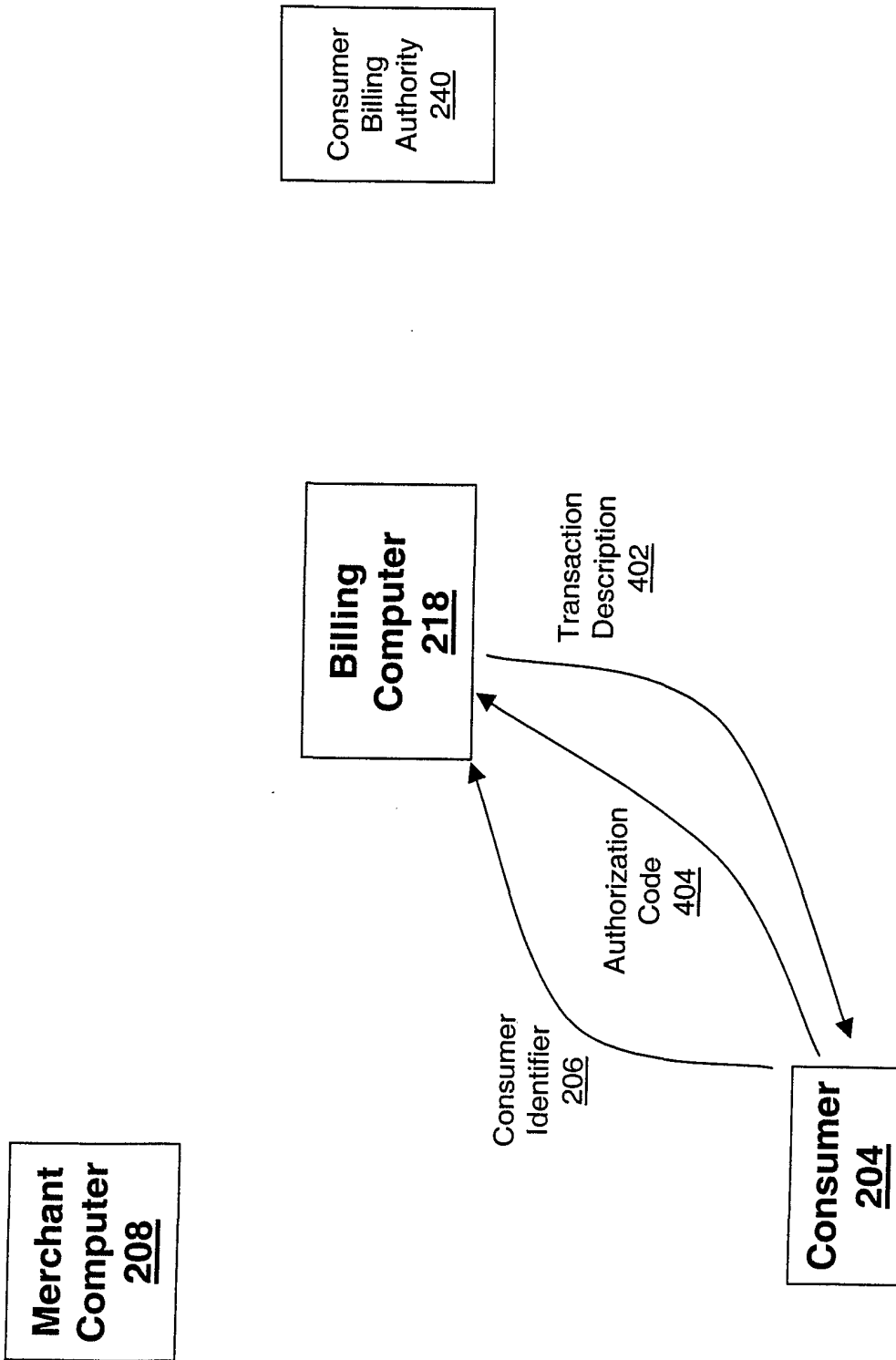

FIGURE 4A

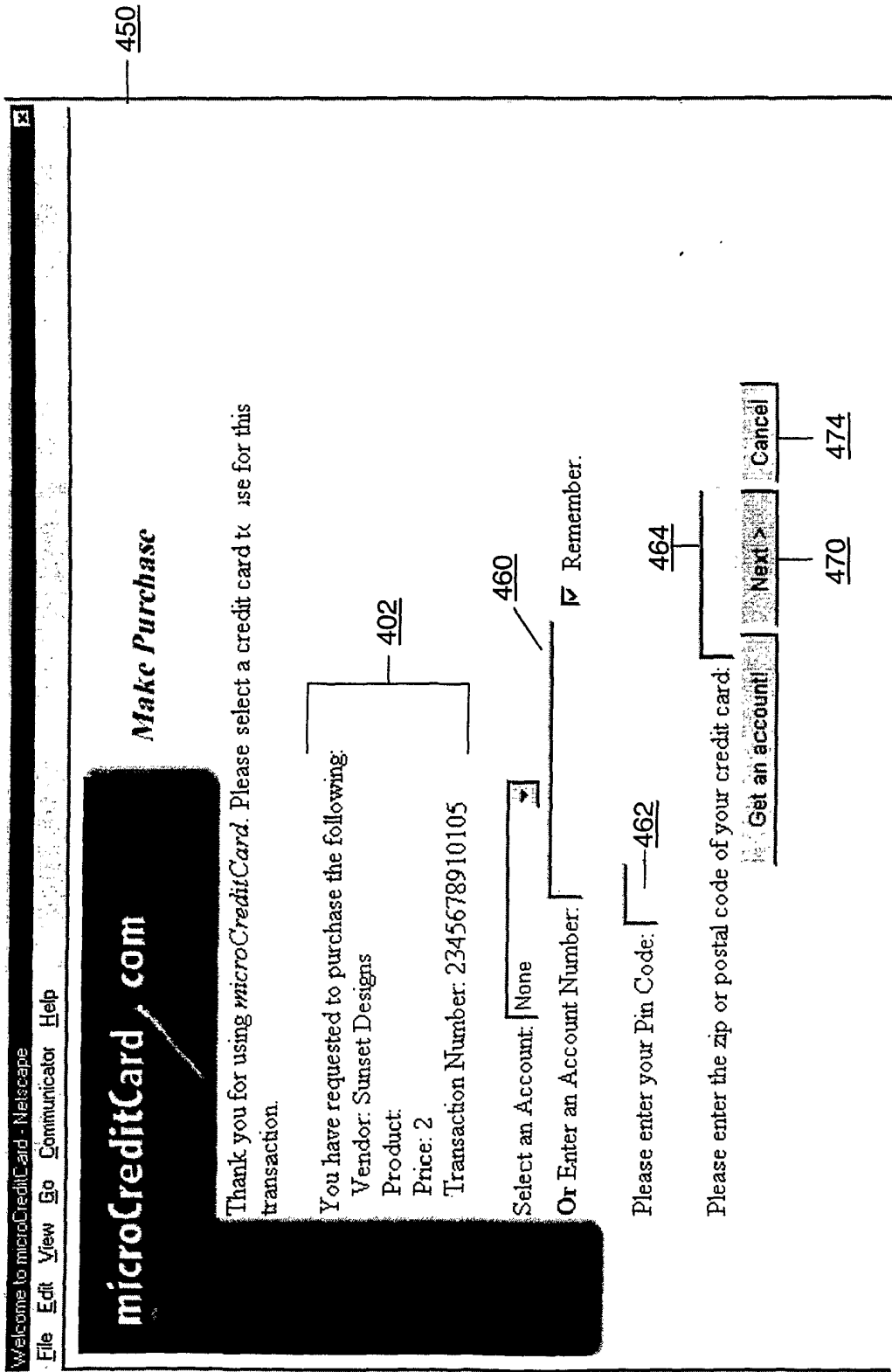
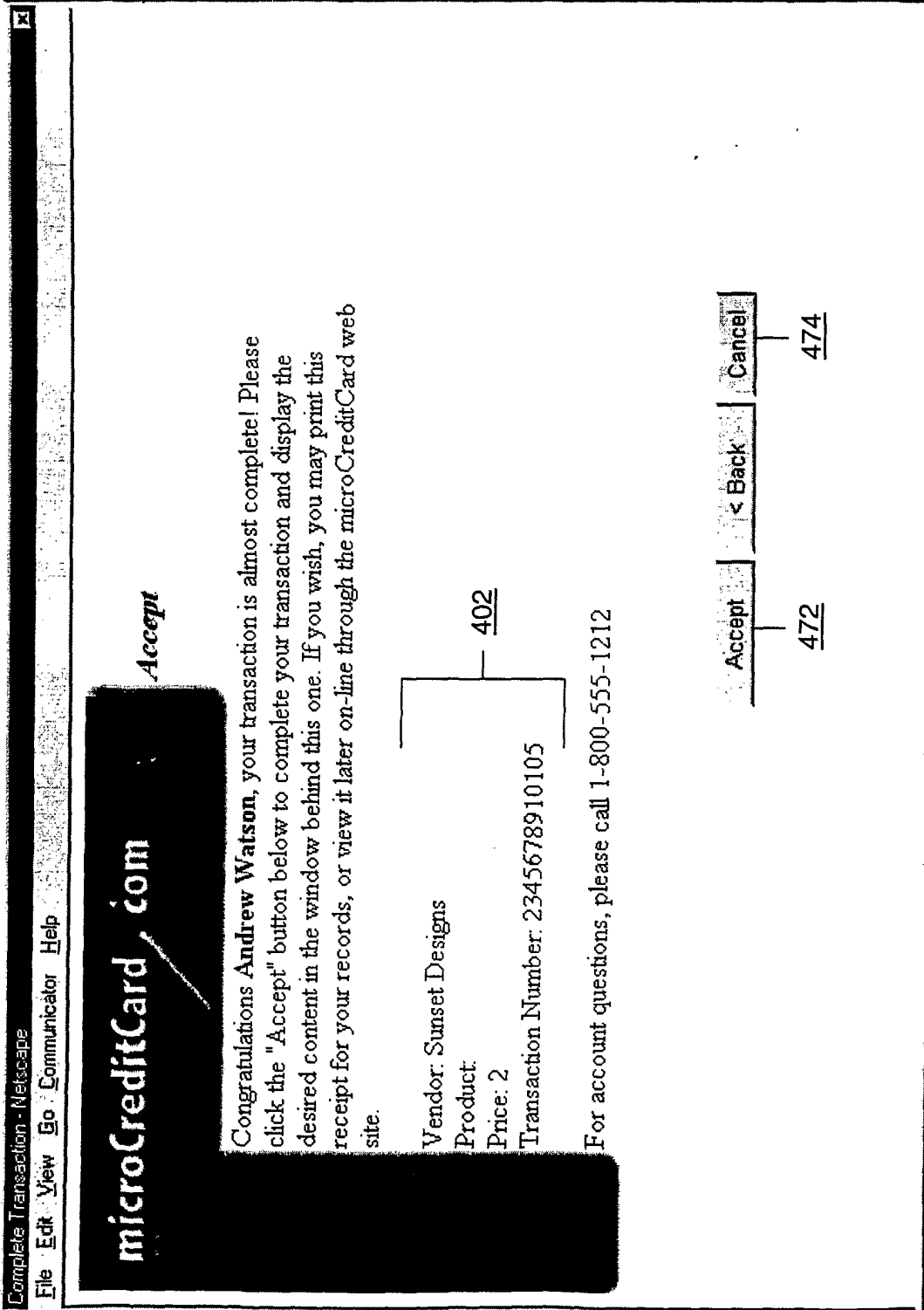

FIGURE 4B

452



402

Accept < Back Cancel

472

474

FIGURE 4C

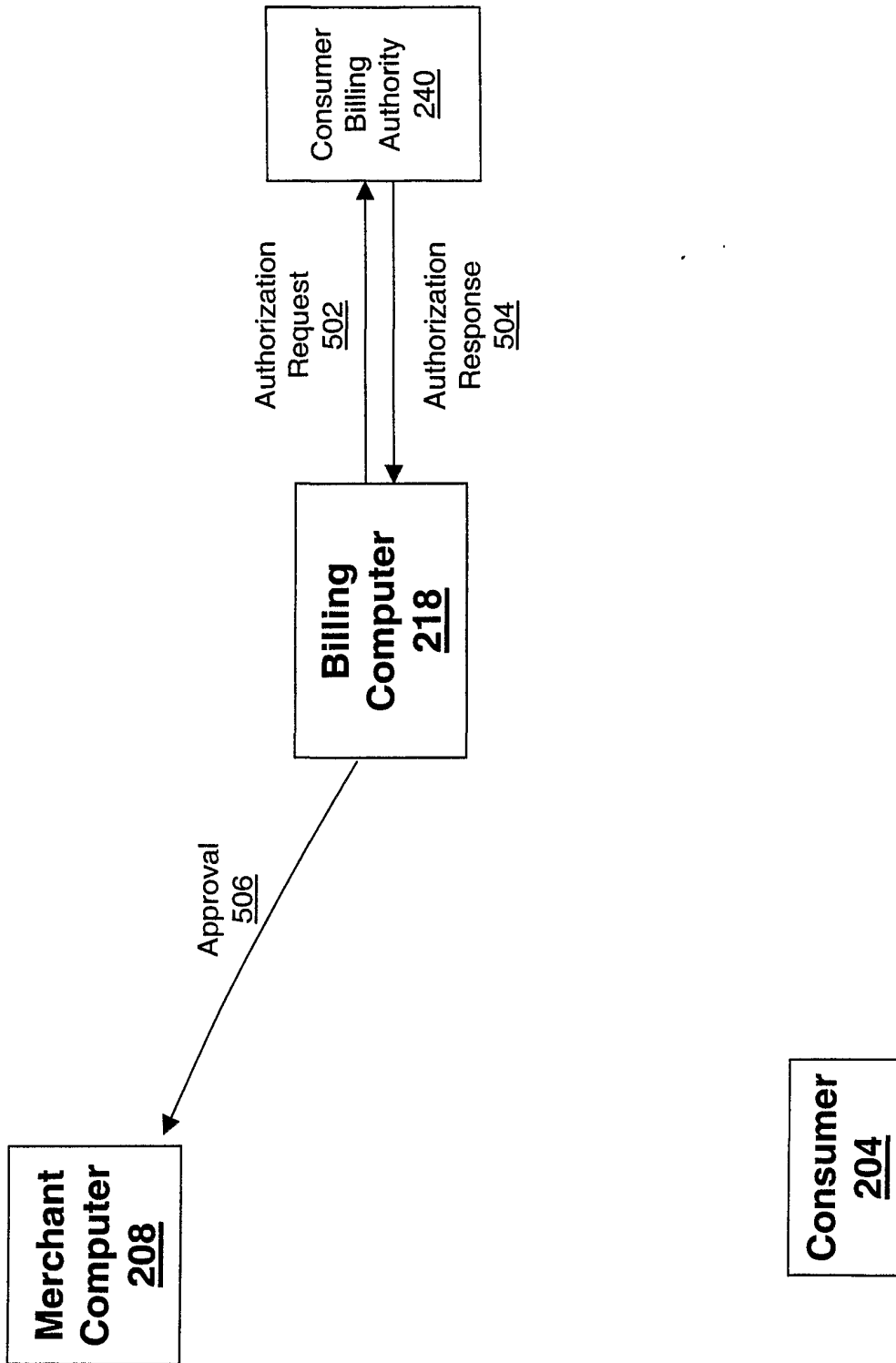

FIGURE 5

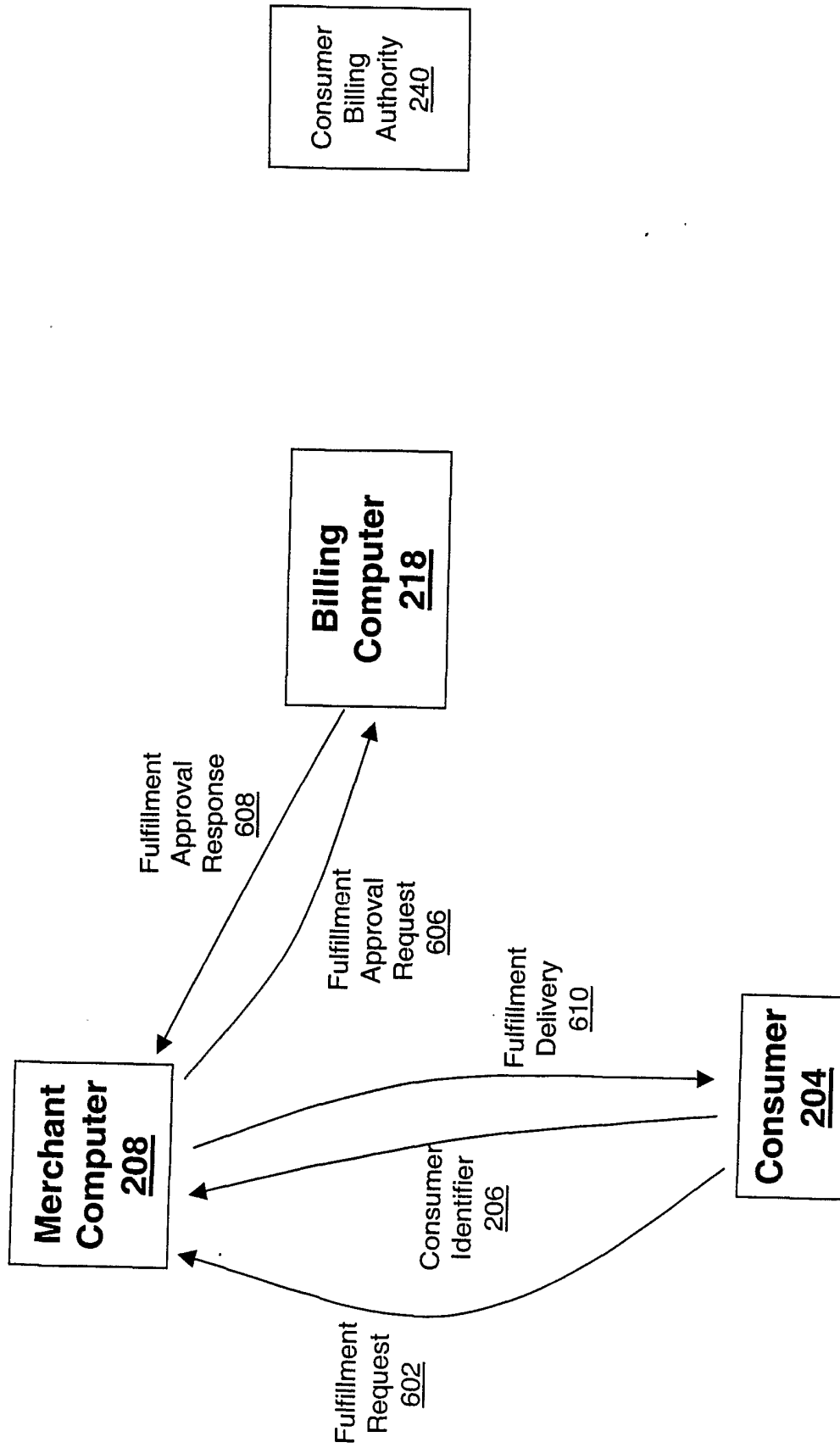

FIGURE 6A

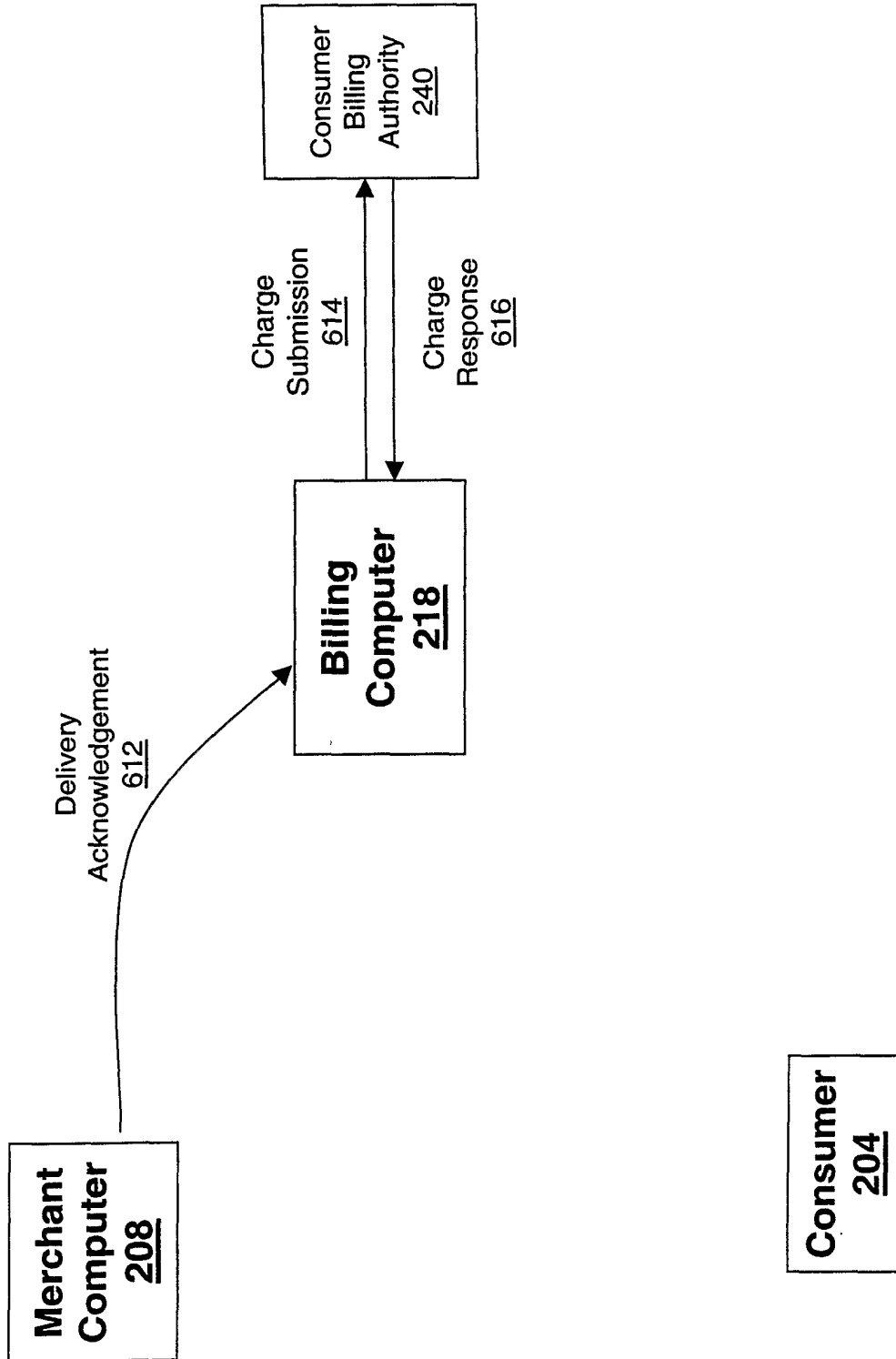

FIGURE 6B

INTERNATIONAL SEARCH REPORT

International application No.
PCT/US01/26718

A. CLASSIFICATION OF SUBJECT MATTER		
IPC(7) : G06F 17/60 US CL : 705/40 According to International Patent Classification (IPC) or to both national classification and IPC		
B. FIELDS SEARCHED		
Minimum documentation searched (classification system followed by classification symbols) U.S. : 705/35-40		
Documentation searched other than minimum documentation to the extent that such documents are included in the fields searched		
Electronic data base consulted during the international search (name of data base and, where practicable, search terms used)		
C. DOCUMENTS CONSIDERED TO BE RELEVANT		
Category*	Citation of document, with indication, where appropriate, of the relevant passages	Relevant to claim No.
A,P	US 6,267,292 B1 (WALKER ET AL.) 31 JULY 2001, SEE ENTIRE DOCUMENT.	1-67
A,P	US 6,182,894 B1 (HACKETT ET AL.) 06 FEBRUARY 2001, SEE ENTIRE DOCUMENT.	1-67
A,P	US 6,175,922 B1 (WANG) 16 JANUARY 2001, SEE ENTIRE DOCUMENT.	1-67
A	US 6,016,504 A (ARNOLD ET AL.) 18 JANUARY 2000, SEE ENTIRE DOCUMENT.	1-67
<input type="checkbox"/> Further documents are listed in the continuation of Box C. <input type="checkbox"/> See patent family annex.		
<p>* Special categories of cited documents:</p> <p>"A" document defining the general state of the art which is not considered to be of particular relevance</p> <p>"E" earlier document published on or after the international filing date</p> <p>"L" document which may throw doubts on priority claim(s) or which is cited to establish the publication date of another citation or other special reason (as specified)</p> <p>"O" document referring to an oral disclosure, use, exhibition or other means</p> <p>"P" document published prior to the international filing date but later than the priority date claimed</p>	<p>"T" later document published after the international filing date or priority date and not in conflict with the application but cited to understand the principle or theory underlying the invention</p> <p>"X" document of particular relevance; the claimed invention cannot be considered novel or cannot be considered to involve an inventive step when the document is taken alone</p> <p>"Y" document of particular relevance; the claimed invention cannot be considered to involve an inventive step when the document is combined with one or more other such documents, such combination being obvious to a person skilled in the art</p> <p>"&" document member of the same patent family</p>	
Date of the actual completion of the international search 16 DECEMBER 2001		Date of mailing of the international search report 10 JAN 2002
Name and mailing address of the ISA/US Commissioner of Patents and Trademarks Box PCT Washington, D.C. 20231 Facsimile No. (703) 305-3230		Authorized officer FRANTZY POINVL <i>James R. Matthews</i> Telephone No. (703) 305-9779