

Nov. 20, 1951

G. D. MATEER

2,575,883

FIRE ALARM

Filed Dec. 1, 1948

Fig. 1.

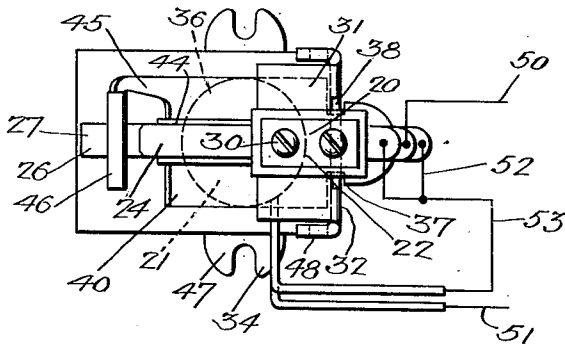

Fig. 2.

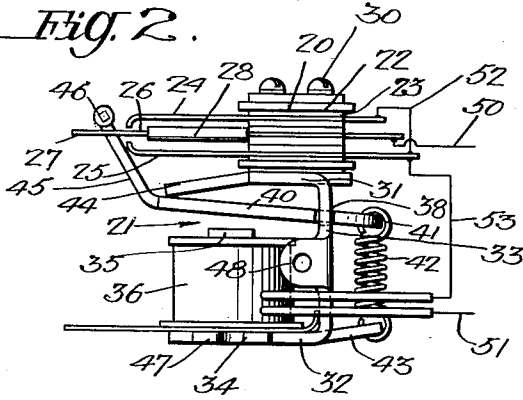

Fig. 3.

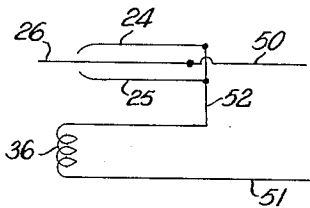
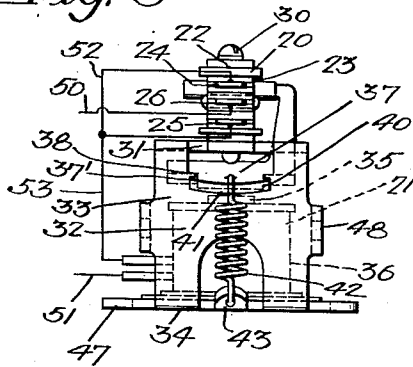

Fig. 4

INVENTOR
George Diehl Mateer
BY
Wm. Stahl, Jackson and Sons
ATTORNEYS

UNITED STATES PATENT OFFICE

2,575,883

FIRE ALARM

George Diehl Mateer, Ardmore, Pa.

Application December 1, 1948, Serial No. 62,871

2 Claims. (Cl. 177—355)

1

The present invention relates to electric alarms particularly of the type employed as rate of rise fire alarms.

A purpose of the invention is to mount a rate of rise switch on the core of an electromagnet and to apply holding action to the switch when the electromagnet is energized by an extension of the armature of the electromagnet preferably operating an extension of the shielded thermostatic element of the switch.

A further purpose is to pivot the electromagnet armature on the core and preferably between the electromagnet and a platform mounted on the core for positioning the switch.

A further purpose is to make a self-contained fire alarm unit from the rate of rise thermostatic switch and a buzzer which acts as an alarm.

Further purposes appear in the specification and in the claims.

In the drawings I have chosen to illustrate a single embodiment of the invention, selecting the particular form shown from the standpoints of convenience in illustration, satisfactory operation and clear demonstration of the principles involved.

Figure 1 is a top plan view of the device of the invention.

Figure 2 is a side elevation of Figure 1.

Figure 3 is an end elevation of Figure 1.

Figure 4 is a circuit diagram.

Diagrammatic circuit connections are included in these views.

Describing in illustration but not in limitation and referring to the drawings:

The alarm of the present invention comprises a thermostatic switch 20, preferably of the rate of rise type, and a buzzer 21.

The switch suitably comprises an insulating mounting pad 22 built up of insulating layers 23 supporting, insulated from one another, an unshielded thermostatic switch element 24, a contact strip 25 and an intermediate shielded thermostatic switch element 26 extending beyond the contact ends of the element 24, and contact strip 25 at 27, and suitably shielded from transfer of heat from the atmosphere by a shield 28. The rate of rise thermostatic switch as here described is well known in the art and is not considered novel per se. As in usual rate of rise thermostats, the fast expanding sides of the thermostatic bi-metal strips are both directed in the same direction and toward the contact strip 25. A predetermined difference in expansion exists between the shielded and unshielded elements.

The mounting pad of the switch is united to-

2

gether and mounted by screws 30 which pass through the pad and through the thermostatic switch elements and contact strip in insulated relation to the elements and strip.

The mounting screws 30 are conveniently fastened to a mounting platform 31 which is desirably formed integrally from a U-shaped steel or iron external core 32 comprising the platform 31 as one arm of the U, a bridge 33 forming an upright of the U and a base 34 forming the other arm of the U. The base 34 is suitably joined as by a press fit with an internal iron core 35 around which is wound an electromagnet coil 35 of the buzzer. Thus the internal iron (steel) core 35 and the U member 32 make up the core of the electromagnet.

The upright 33 is conveniently slotted at 37 near the platform and the slot provided with shoulders 37' which extend laterally into the space at the base of the slot and receive and make rocking pivotal engagement with the walls of slots 38 in a suitable magnetic (iron or steel) armature 40 of the electromagnet.

Beyond the upright of the core the armature is extended at 41 to act as a spring attachment, and there engages a tension spring 42 acting from an abutment 43 extending from the core. The platform 31 is desirably extended beyond the switch pad and sloped at 44 to engage and stop the motion of the armature under the action of the spring. At the outer end of the armature an extension 45 therefrom is carried around and over the extension 27 of the shielded thermostatic switch element 26 to mount a switch operator 46 which on energizing of the electromagnet will cause the switch to remain closed and thus act as a holding switch operator. At other times the operator is free from engagement with the switch.

Mounting lugs for the alarm are provided at 47 on the base and at 48 on the sides, by extensions from the core.

The device is connected to a source of alternating current at 50 and 51, conveniently to one terminal of the coil and to the shielded thermostatic switch element 26. The unshielded thermostatic switch elements are connected in parallel at 52 and connected to the other terminal of the coil at 53.

The electrical connections are shown on the circuit diagram of Figure 4.

In operation, it will be evident that the thermostatic switch will remain open as long as no emergency condition arises. If the temperature rises gradually to a moderate extent both thermo-

static switch elements will shift together in the same direction and no contact will be made by the switch. If the rise is rapid, the shielded thermostatic switch element will move downward less rapidly than the unshielded element, and at the predetermined rate of rise unshielded element 24 will make contact with the shielded element 26. On a slowly rising temperature when an abnormal temperature is reached the shielded thermostatic switch element 26 will move down and make contact with the contact strip 25. The space between the shielded thermostatic element and the contact strip can be adjusted to determine the temperature at which the alarm will go off on a slow rise in temperature.

Once contact has been made, the coil is energized by alternating current, which attracts the armature and causes it to be pulled toward the internal core, at the same time, through the action of the switch operator 45, holding the switch closed by contact between the shielded element 26 and the contact strip 25. Due to the alternating current wave variation, however (depending on the frequency which will ordinarily be commercial frequency such as 60 cycles), the buzzer will vibrate in step with the alternating current without breaking the circuit. Thus the alarm will continue until it is switched off, as by disconnecting a master switch of the alarm system not shown.

The invention is particularly advantageous because it is very cheap and convenient for use by the individual householder or for industrial purposes.

In view of my invention and disclosure variations and modifications to meet individual whim or particular need will doubtless become evident to others skilled in the art, to obtain all or part of the benefits of my invention without copying the structure shown, and I therefore, claim all such insofar as they fall within the reasonable spirit and scope of my claims.

Having thus described my invention what I claim as new and desire to secure by Letters Patent is:

1. In an alarm, a buzzer having a core, having a coil around the core, having an armature pivotally mounted on one side of the coil and

adapted to vibrate with respect to the coil and having a spring biasing the armature toward a position remote from the coil, an extension from the core to a position beyond the armature, a rate of rise thermostatic switch mounted on the extension and having an unshielded thermostatic switch element, a contact strip and an intermediate shielded thermostatic switch element, extending endwise beyond the unshielded element, connections placing the unshielded element and the contact strip electrically in parallel, connections placing the rate of rise thermostatic switch electrically in series with the coil, and an extension from the armature on the opposite side of the coil from the pivot engaging the extended end of the shielded element to move the same into contact with the contact strip when the coil is energized.

2. In an alarm, a magnetic ferrous support having a body, a base at one end of the body, and a platform at the other end of the body, a rate of rise thermostatic switch mounted on the platform, an interior magnetic core mounted on the base and extending toward the platform, whereby with the support it completes a magnetic circuit, a coil around the interior magnetic core, an armature pivotally mounted on the body to one side of the core and extending between the end of the interior core and the platform, a biasing spring acting on the armature to urge it toward the platform and an extension from the end of the armature beyond the coil engaging the rate of rise thermostatic switch to hold the same closed when the coil is energized.

GEORGE DIEHL MATEER.

REFERENCES CITED

The following references are of record in the file of this patent:

UNITED STATES PATENTS

Number	Name	Date
587,998	MacKenzie	Aug. 10, 1897
1,066,731	Jaynes	July 8, 1913
2,299,669	Werner	Oct. 20, 1942
2,434,186	Wilson	Jan. 6, 1948
2,453,726	Prouty et al.	Nov. 16, 1948
2,456,038	Young	Dec. 14, 1948
2,479,468	Bundy	Aug. 16, 1949