

(19) World Intellectual Property Organization  
International Bureau



(43) International Publication Date  
1 September 2011 (01.09.2011)

(10) International Publication Number  
**WO 2011/106207 A1**

(51) International Patent Classification:  
A61F 15/00 (2006.01)

(21) International Application Number:  
PCT/US2011/024952

(22) International Filing Date:  
16 February 2011 (16.02.2011)

(25) Filing Language: English

(26) Publication Language: English

(30) Priority Data:  
12/712,833 25 February 2010 (25.02.2010) US

(71) Applicant (for all designated States except US): **ALLERGAN, INC.** [US/US]; 2525 Dupont Drive, T2-7h, Irvine, California 92612 (US).

(72) Inventors; and

(75) Inventors/Applicants (for US only): **BIRK, Janel A.** [US/US]; 1110 Nightingale Place, Oxnard, California 93036 (US). **SNOW, Sean** [US/US]; 1000 Bailard Avenue #C, Carpinteria, California 93013 (US).

(74) Agents: **DONOVAN, Stephen** et al.; Allergan, Inc., 2525 Dupont Drive, Irvine, California 92612 (US).

(81) Designated States (unless otherwise indicated, for every kind of national protection available): AE, AG, AL, AM, AO, AT, AU, AZ, BA, BB, BG, BH, BR, BW, BY, BZ,

CA, CH, CL, CN, CO, CR, CU, CZ, DE, DK, DM, DO, DZ, EC, EE, EG, ES, FI, GB, GD, GE, GH, GM, GT, HN, HR, HU, ID, IL, IN, IS, JP, KE, KG, KM, KN, KP, KR, KZ, LA, LC, LK, LR, LS, LT, LU, LY, MA, MD, ME, MG, MK, MN, MW, MX, MY, MZ, NA, NG, NI, NO, NZ, OM, PE, PG, PH, PL, PT, RO, RS, RU, SC, SD, SE, SG, SK, SL, SM, ST, SV, SY, TH, TJ, TM, TN, TR, TT, TZ, UA, UG, US, UZ, VC, VN, ZA, ZM, ZW.

(84) Designated States (unless otherwise indicated, for every kind of regional protection available): ARIPO (BW, GH, GM, KE, LR, LS, MW, MZ, NA, SD, SL, SZ, TZ, UG, ZM, ZW), Eurasian (AM, AZ, BY, KG, KZ, MD, RU, TJ, TM), European (AL, AT, BE, BG, CH, CY, CZ, DE, DK, EE, ES, FI, FR, GB, GR, HR, HU, IE, IS, IT, LT, LU, LV, MC, MK, MT, NL, NO, PL, PT, RO, RS, SE, SI, SK, SM, TR), OAPI (BF, BJ, CF, CG, CI, CM, GA, GN, GQ, GW, ML, MR, NE, SN, TD, TG).

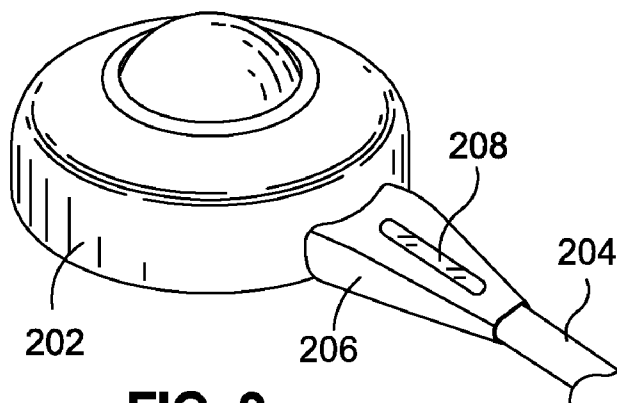
Declarations under Rule 4.17:

- as to applicant's entitlement to apply for and be granted a patent (Rule 4.17(ii))
- as to the applicant's entitlement to claim the priority of the earlier application (Rule 4.17(iii))

Published:

- with international search report (Art. 21(3))

(54) Title: PRESSURE SENSING GASTRIC BANDING SYSTEM



**FIG. 2**

(57) Abstract: An implantable device monitors a pressure of fluid within an inflatable portion of a gastric band. The implantable device comprises a tube defining a lumen, and a pressure sensor positioned within at least one of the lumen or the tube. The pressure sensor is configured to sense the pressure of the fluid within the inflatable portion of the gastric band. The pressure sensor is also configured to transmit a pressure signal based on the pressure to a microcontroller, which transmits the pressure signal to a remote control device. The pressure sensor confers strain relief upon at least a portion of the tube, and the pressure sensor shields at least a portion of the tube from puncture by a needle.

WO 2011/106207 A1

**PRESSURE SENSING GASTRIC BANDING SYSTEM**

BY

SEAN SNOW AND JANEL A. BIRK

**RELATED APPLICATION**

[0001] This application claims the benefit of U.S. Patent Application Serial Number 12/712,833, filed on February 25, 2010, the entire disclosure of which is incorporated herein by this specific reference.

**FIELD**

[0002] The present invention generally relates to medical systems and apparatus and uses thereof for treating obesity and/or obesity-related diseases, and more specifically, relates to pressure sensing for gastric banding systems.

**BACKGROUND**

[0003] Adjustable gastric banding apparatus have provided an effective and substantially less invasive alternative to gastric bypass surgery and other conventional surgical weight loss procedures. Despite the positive outcomes of invasive weight loss procedures, such as gastric bypass surgery, it has been recognized that sustained weight loss can be achieved through a laparoscopically-placed gastric band, for example, the LAP-BAND® (Allergan, Inc., Irvine, CA) gastric band or the LAP-BAND AP® (Allergan, Inc., Irvine, CA) gastric band. Generally, gastric bands are placed about the cardia, or upper portion, of a patient's stomach forming a stoma that restricts the food's passage into a lower portion of the stomach. When the stoma is of an appropriate size that is restricted by a gastric band, food held in the upper portion of the stomach provides a feeling of satiety or fullness that discourages overeating. Unlike gastric bypass procedures, gastric band apparatus are reversible

and require no permanent modification to the gastrointestinal tract.

**[0004]** Over time, a stoma created by a gastric band may need adjustment in order to maintain an appropriate size, which is neither too restrictive nor too passive. Accordingly, prior art gastric band systems provide a subcutaneous fluid access port connected to an expandable or inflatable portion of the gastric band. By adding fluid to or removing fluid from the inflatable portion, for example, by means of a hypodermic needle inserted into the access port, the effective size of the gastric band can be adjusted to provide a tighter or looser constriction. The level of constriction is related to the amount of fluid in the gastric band system. The level of constriction is also related to the pressure within the gastric band system.

**[0005]** An implantable pressure sensor for monitoring blood pressure is disclosed in U.S. Patent No. 5,120,313 to Elftman. However, the system of Elftman is percutaneous and extends partially outward from the skin, and is thus unsuitable for complete implantation.

**[0006]** A previous attempt to provide a medical pressure sensor may be found in U.S. Patent No. 5,554,113 to Novak et al. While the Novak sensor is sterilizable, it is not fully implantable and requires a percutaneous conduit.

**[0007]** Other attempts to provide a medical pressure sensor may be found in U.S. Patent No. 6,024,704 to Meador et al. and in U.S. Patent No. 5,535,752 to Halperin et al. However, although the sensors of Meador and Halperin are implantable, they are energized by an implanted battery, and both are specifically intended for use within the heart and in connection with an implanted pulse generator.

**[0008]** Yet another attempt to provide a medical pressure sensor may be found in U.S. Patent No. 6,221,024 to Miesel. The sensor

of Miesel utilizes an incompressible oil as a pressure transfer medium, but does not address minimizing damaged caused by thermal expansion.

**[0009]** Still another attempt to provide a medical pressure sensor may be found in U.S. Patent No. 7,021,147 to Subramanian et al. The sensor of Subramanian addresses thermal expansion but limits the scope to utilizing fillers with low or negative coefficients of thermal expansion.

**[0010]** A prior attempt to provide pressure monitoring for a gastric banding system may be found in U.S. Patent Application Publication No. 2006/0189888 by Hassler et al. However, the pressure sensor of Hassler is specifically part of the access port, and thus does not permit the pressure sensor to be used with preexisting access ports.

**[0011]** Another prior attempt to provide pressure monitoring for a gastric banding system may be found in U.S. Patent Application Publication No. 2008/0221598 by Dlugos et al. However, the pressure sensors of Dlugos do not confer strain relief or puncture resistance features.

**[0012]** It remains desirable to monitor pressure within a gastric band system. Thus, tubing-based pressure sensors for gastric banding systems are described herein.

### **SUMMARY**

**[0013]** Generally described herein are pressure sensors for gastric band systems, and methods of use thereof. The apparatus, systems and methods described herein aid in facilitating obesity control and/or treating obesity-related diseases, and may be non-invasive once implanted.

**[0014]** In one embodiment, an implantable device is configured for monitoring static and fluctuating pressure levels of a fluid moving to and from an inflatable portion of a gastric band. The implantable device comprises a housing defining a cavity and

having an open top portion, and a flexible membrane covering the open top portion of the housing and having an inner surface facing the cavity and an outer surface capable of contacting the fluid. The implantable device further comprises a pressure transfer fluid located within the cavity, and a sensing element, positioned within the cavity of the housing and positioned adjacent to the flexible membrane. The sensing element measures a pressure on the flexible membrane. The pressure is caused by the fluid contacting the outer surface of the flexible membrane. The sensing element converts the pressure to a pressure signal.

**[0015]** The implantable device further comprises a microcontroller positioned within the cavity of the housing and coupled to the sensing element. The microcontroller is configured to transmit the pressure signal received from the sensing element to a location external to the implantable device.

**[0016]** In another embodiment, an implantable device is configured to monitor a pressure of fluid within an inflatable portion of a gastric band. The implantable device comprises a tube defining a lumen and having a first end and a second end. The second end is connected to the inflatable portion of the gastric band for allowing the fluid to flow through the lumen. The implantable device further comprises a pressure sensor positioned within at least one of the lumen or the tube. The pressure sensor is configured to sense the pressure of the fluid within the inflatable portion of the gastric band, and the pressure sensor is configured to transmit a pressure signal based on the pressure to a remote control device. Further, the pressure sensor comprises a rigid housing conferring strain relief upon at least a portion of the tube, and the pressure sensor shields at least a portion of the tube from puncture by a needle.

**[0017]** In another embodiment, a system is configured to facilitate obesity control. The system comprises an implantable gastric banding device including an inflatable member for containing fluid and restricting a patient's cardia, and an implantable access port coupled to the implantable gastric banding device via tubing. The implantable access port is configured to control pressure within the inflatable member.

**[0018]** The system further comprises an external remote control device capable of communicating with and powering a pressure sensor and the pressure sensor disposed at least partially within the tubing. The pressure sensor comprises a housing defining a cavity and having an open top portion, and a flexible membrane covering the open top portion of the housing and having an inner surface facing the cavity and an outer surface capable of contacting a fluid within the tubing.

**[0019]** The pressure sensor further comprises a pressure transfer fluid located within the cavity, and a sensing element, positioned within the cavity of the housing and positioned adjacent to the flexible membrane. The sensing element is configured to measure a pressure on the flexible membrane. The pressure is caused by the fluid contacting the outer surface of the flexible membrane. The pressure sensor is configured to convert the pressure to a pressure signal, and to transmit the pressure signal to a remote device.

**[0020]** In another embodiment, a system is configured to facilitate obesity control. The system comprises an implantable gastric banding device including an inflatable member for containing fluid and restricting a patient's cardia, an implantable fluid reservoir, and an implantable pump unit for controlling pressure within the inflatable member. The implantable pump unit is in communication with the fluid reservoir and the gastric banding device via tubing.

**[0021]** The system further comprises an implantable access port coupled to the implantable pump unit, an external remote control device capable of communicating with and powering the implantable pump unit and a pressure sensor, and the pressure sensor disposed at least partially within the tubing.

**[0022]** The pressure sensor comprises a housing defining a cavity and having an open top portion, and a flexible membrane covering the open top portion of the housing and having an inner surface facing the cavity and an outer surface capable of contacting a fluid within the tubing.

**[0023]** The pressure sensor further comprises a pressure transfer fluid located within the cavity, and a sensing element, positioned within the cavity of the housing and positioned adjacent to the flexible membrane. The sensing element is configured to measure a pressure on the flexible membrane. The pressure is caused by the fluid contacting the outer surface of the flexible membrane. The pressure sensor is configured to convert the pressure to a pressure signal. The pressure sensor further comprises a microcontroller positioned within the cavity of the housing and coupled to the sensing element. The microcontroller is configured to process the pressure signal received from the sensing element and transmit the processed pressure signal to a remote device.

**[0024]** In another embodiment, a method of retrofitting a tubing-based pressure sensor to a previously implanted gastric banding system is provided. The method comprises removing a portion of existing tubing from the gastric banding system, and inserting a portion of new tubing into the gastric banding system. The portion of the new tubing contains at least one pressure sensor disposed at least partially therein.

**[0025]** The pressure sensor comprises a housing defining a cavity and having an open top portion, and a flexible membrane covering the open top portion of the housing and having an inner surface

facing the cavity and an outer surface capable of contacting a fluid within the tubing.

**[0026]** The pressure sensor further comprises a pressure transfer fluid located within the cavity, and a sensing element, positioned within the cavity of the housing and positioned adjacent to the flexible membrane. The sensing element is configured to measure a pressure on the flexible membrane. The pressure is caused by the fluid contacting the outer surface of the flexible membrane. The pressure sensor is configured to convert the pressure to a pressure signal. The pressure sensor further comprises a microcontroller positioned within the cavity of the housing and coupled to the sensing element. The microcontroller is configured to process the pressure signal received from the sensing element and transmit the processed pressure signal to a location external to the pressure sensor.

**[0027]** The method further comprises coupling the portion of the new tubing to at least one of: a previously implanted access port, a previously implanted pump, or a portion of the existing tubing.

#### **BRIEF DESCRIPTION OF THE DRAWINGS**

**[0028]** FIG. 1A illustrates an overall schematic view of an example configuration of components according to an embodiment of the present invention.

**[0029]** FIG. 1B illustrates an overall schematic view of an example configuration of components according to an embodiment of the present invention.

**[0030]** FIG. 2 illustrates a pressure sensor disposed in a strain relief portion located between an access port and tubing in an example configuration of components according to an embodiment of the present invention.

[0031] FIGS. 3A through 3D illustrate cross-sections of an example tubing incorporating a pressure sensor according to an embodiment of the present invention.

[0032] FIGS. 4A and 4B illustrate cross-sections of tubing having an example sensor disposed in the tubing wall according to an embodiment of the present invention.

[0033] FIG. 4C illustrates an example configuration of components including a hard connector and stress relief components according to an embodiment of the present invention.

[0034] FIGS. 5A and 5B illustrate cross-sections of an example pressure sensor according to an embodiment of the present invention.

[0035] FIG. 5C illustrates example components of a microcontroller and a pressure transducer according to an embodiment of the present invention.

#### DETAILED DESCRIPTION

[0036] The present invention generally provides pressure sensing for gastric banding systems, for example, for treatment of obesity and obesity related conditions.

[0037] Turning now to FIG. 1A, a gastric banding system **100A** in accordance with one embodiment of the present invention generally includes an access port **102**, a tubing **104**, a gastric band **106** having at least one inflatable member **107**, a pressure sensor **108**, and a remote controller unit **110** (not shown). Each of the components of the system **100**, other than the remote controller unit **110**, is implantable in a patient using conventional surgical techniques. The access port **102** may be used, for example, with a hypodermic needle, to fill and drain the gastric band **106**, for example responsive to pressure measured by the pressure sensor **108** and communicated to the remote controller unit **110**.

[0038] Turning now to FIG. 1B, a gastric banding system **100B** in accordance with another embodiment of the present invention generally includes an access port **102**, a tubing **104**, a gastric band **106** having at least one inflatable member **107**, a pressure sensor **108**, a remote controller unit **110** (not shown), a reservoir **112**, and a high precision pump unit **114**. Each of the components of the system **100B**, other than the remote controller unit **110**, is implantable in a patient using conventional surgical techniques. The high precision pump unit **114** can be used to complement or replace the access port **102** for adjusting inflation of the gastric band **106**, for example, responsive to pressure measured by the pressure sensor **108**. The high precision pump **114** may also include a microcontroller or a microprocessor to receive a telemetric signal from the remote controller unit **110**. The microcontroller or the microprocessor may be used to the control the high precision pump **114**.

[0039] With reference to FIGS. 1A and 1B, in various example embodiments, one or more pressure sensors **108** are coupled to the tubing **104**. When compared to conventional gastric banding systems having no pressure sensing components, or having pressure sensing components integrated into access ports, pumps, and/or the like, the presently described systems and apparatus offer several benefits. By locating the pressure sensor **108** within the wall of the tubing **104** and/or within the tubing **104** lumen, the tubing **104** incorporating the pressure sensor **108** may be easily retrofitted to preexisting access ports. Additionally, by locating the pressure sensor **108** within the wall of the tubing **104** and/or within the tubing **104** lumen, interference between the pressure sensor **108** and electrical and/or mechanical components of an access port, a pump, a valve, or other components of a gastric banding system may be reduced and/or eliminated, for example due to increased spacing between the pressure sensor **108** and other components. Further, locating

the pressure sensor **108** within the wall of the tubing **104** allows the pressure sensor **108** to confer additional puncture resistance to at least the corresponding portion of the tubing **104**.

Moreover, utilization of a substantially rigid pressure sensor **108** and/or associated hard connectors and/or other components allows the pressure sensor **108** to act as partial strain relief for the tubing **104**.

[0040] Further, by locating the pressure sensor **108** away from the access port, the pump, the valves, and/or other components of a gastric banding system, certain electrical portions of the pressure sensor **108**, such as antenna, are not affected by metal parts which may be in such other components of a gastric banding system. In this manner, the pressure sensor **108** can achieve improved powering and/or communication ranges due to the reduced interference.

[0041] Referring again to FIG. 1B, in an example embodiment, the high precision pump unit **114** is connected to the reservoir **112** and the gastric band **106** via the tubing **104**, and can move precisely metered volumes of fluid in or out of the gastric band **106**. Moving the fluid into the gastric band **106** causes inflation of at least one bladder, or inflatable member **107** of the gastric band **106** and constricts around the cardia, or upper portion of the stomach, forming a stoma that restricts the passage of food into a lower portion of the stomach. This stoma can provide a patient with a sensation of satiety or fullness that discourages overeating. In contrast, moving fluid out of the at least one inflatable member **107** of the gastric band **106** contracts the pressure around the cardia and allows a stoma to be at least partially released and regains the patient's hunger sensation.

[0042] The high precision pump unit **114** is implanted within a patient, and therefore, is non-biodegradable. The encasement of the high precision pump unit **114** may be non-hermetically or

hermetically sealed from the *in situ* environment and at least partially formed of any rugged plastic material, including polypropylene, cyclicolephin co-polymer, nylon, and other compatible polymers and the like, or at least partially formed of a non-radioopaque metal. The encasement has a smooth exterior shape, with no jagged edges, to minimize foreign body response and tissue irritation. The unit itself is also sterilizable, preferably dry heat sterilizable before implantation.

**[0043]** In one example embodiment, the encasement or housing of the high precision pump unit **114** has an internal volume of between about 0.75 in<sup>3</sup> to about 1.6 in<sup>3</sup>. The high precision pump unit **114** can be arranged in any fashion appropriate for delivering and removing precise amounts of fluid from the gastric band **106** and the reservoir **112**.

**[0044]** The high precision pump unit **114** can be actively or passively driven. If the high precision pump unit **114** is actively driven, a local power source such as a battery (not shown) is provided to drive the high precision pump unit **114**. If the high precision pump unit **114** is passively driven, it may be inductively powered by a device external to the high precision pump unit **114**. In an exemplary configuration, the high precision pump unit **114** is passively driven through inductive power, for example, power delivered by the remote controller unit **110**. In one example embodiment, the high precision pump unit **114** is an inductively powered, electrically driven, positive displacement piezoelectric pump. The high precision pump unit **114** provides one means to move fluid into and/or out of the gastric band **106** and/or the reservoir **112**.

**[0045]** In an example embodiment, the high precision pump unit **114** can move fluid from the reservoir **112** to the gastric band **106** at rates higher than about 0.5 cc/min, for example higher than about 1 cc/min for band pressures less than about 10 psi

(about 138 kPa) relative to the reservoir pressure.

Alternatively, fluid can be drained from the gastric band **106** to the reservoir **112** at rates higher than about 0.5 cc/min, for example, higher than about 1 cc/min for band pressures above about 0.2 psi (about 1.38 kPa).

**[0046]** Additional details regarding adjustable gastric banding systems and exemplary components thereof may be found in Birk, U.S. Patent Application Publication No. 2009/0270904, and Birk, U.S. Patent Application Publication No. 2007/0156013, each of which are commonly assigned herewith and incorporated in their entirety herein by this specific reference.

**[0047]** In an example embodiment, the reservoir **112** is a soft, collapsible balloon made of a biocompatible polymer material, for example, silicone, which holds a reserve of a biocompatible fluid, for example, saline, to allow for adjustments in the size of the gastric band **106**. The reservoir **112** is preferably fully collapsible and can contain the extra fluid required to increase the volume of the gastric band **106** to therapeutic levels.

Further, the reservoir **112** also may have excess capacity so the gastric band **106** may be fully drained into it without the reservoir **112** being filled beyond its maximum capacity.

**[0048]** The fluids used within the systems include any fluid that is biocompatible. Consequently, the fluid has no adverse effect on the patient in the unlikely event that a leak emanates from the system. The fluid can simply be water or any biocompatible polymer oil such as castor oil. In an example embodiment, the fluid is saline.

**[0049]** The tubing **104** is any biocompatible flexible tubing that does not degrade *in vivo*. The tubing **104** is configured to withstand hydraulic forces up to about 30 psi (about 206 kPa) without leakage. This hydraulic pressure tolerance is true of the entire fluid path of the systems described herein. Although the systems described herein do not generally leak, if they do,

in general fluid is not lost at a rate greater than about 0.2cc/yr, or about 0.1cc/yr.

**[0050]** Other biocompatible and biostable polymers which are useful for forming the reservoir **112** and/or the tubing **104** include polyolefins, polyisobutylene and ethylene-alphaolefin copolymers; acrylic polymers and copolymers, ethylene-co-vinylacetate, polybutylmethacrylate, vinyl halide polymers and copolymers, such as polyvinyl chloride; polyvinyl ethers, such as polyvinyl methyl ether; polyvinylidene halides, such as polyvinylidene fluoride and polyvinylidene chloride; polyacrylonitrile, polyvinyl ketones; polyvinyl aromatics, such as polystyrene, polyvinyl esters, such as polyvinyl acetate; copolymers of vinyl monomers with each other and olefins, such as ethylene-methyl methacrylate copolymers, acrylonitrile-styrene copolymers, ABS resins, and ethylene-vinyl acetate copolymers; polyamides, such as Nylon 66 and polycaprolactam; alkyd resins; polycarbonates; polyoxymethylenes; polyimides; polyethers; epoxy resins, polyurethanes; rayon; rayon-triacetate; cellulose, cellulose acetate, cellulose butyrate; cellulose acetate butyrate; cellophane; cellulose nitrate; cellulose propionate; cellulose ethers; and carboxymethyl cellulose.

**[0051]** Turning now to FIG. 2, in an example embodiment, an access port **202** is coupled to a tubing **204** via a strain relief portion **206**. A pressure sensor **208** is disposed within the strain relief portion **206**. The strain relief portion **206** may comprise a thickened portion of the tubing **204**; alternatively, the strain relief portion **206** may comprise a material different from the tubing **204**. In these embodiments, the pressure sensor **208** may be disposed within the strain relief portion **206** in a location configured to allow the pressure sensor **208** to detect changes in the pressure in the fluid passing through the strain relief portion **206** and/or the tube **204**. Additionally, the

strain relief portion **206** and/or the pressure sensor **208** help protect the tubing **204** from errant needle sticks, for example, needle sticks intended to contact the nearby access port **202**. For example, the pressure sensor **208** may comprise material resistant to puncture by a sharp object.

[0052] Moreover, in accordance with principles of the present invention, a pressure sensor may be integrated into and/or coupled to the tubing **104** in any suitable manner. For example, various configurations of a pressure sensor **308** as integrated into and/or contained within a tubing **304** are illustrated in FIGS. 3A through 3D. In one example embodiment illustrated in FIG. 3A, at least a portion of the tubing **304** has a generally rectangular cross-section and defines an inner lumen **310**. The pressure sensor **308** is disposed within the tubing **304** adjacent to the lumen **310**. In this configuration, the pressure sensor **308** and the lumen **310** may be aligned "side by side" with respect to the skin of a patient.

[0053] In another example embodiment illustrated in FIG. 3B, at least a portion of the tubing **304** has a somewhat "bullet"-shaped cross section and defines an inner lumen **310**. The pressure sensor **308** is disposed within the tubing **304** adjacent to the lumen **310**. In this configuration, the pressure sensor **308** and the lumen **310** may be aligned "top and bottom" with respect to the skin of a patient. In this manner, the pressure sensor **308** and/or the tubing **304** may at least partially protect the lumen **310** from damage or puncture, for example, from errant needle sticks. Moreover, any suitable cross-sections of the tubing **304** and/or the pressure sensor **308** may be aligned "top to bottom" in order to locate the pressure sensor **308** at least partially between a portion of the lumen **310** and an incoming needle or other device which may potentially damage the tubing **304**.

[0054] In another example embodiment illustrated in FIG. 3C, at least a portion of the tubing **304** has a somewhat "egg"-shaped

cross section and defines a similarly shaped inner lumen **310**. In this configuration, the tubing **304** may also be considered to have a cross-section resembling a conical frustum configured with partially rounded edges. The pressure sensor **308** is disposed within the lumen **310**. In this manner, the pressure sensor **308** may be in direct contact with the fluid contained in the lumen **310** while still allowing flow of the fluid through the lumen **310**, for example, when the pressure sensor **308** is configured with a substantially circular cross-section or other cross-section different from the cross-section of the lumen **310**.

[0055] In another example embodiment illustrated in FIG. 3D, at least a portion of the tubing **304** has a circular cross-section. Within the tubing **304**, an inner lumen **310** having a cross-section with a main lumen area and a plurality of extensions therefrom is defined. The pressure sensor **308** is disposed within the main lumen area of the lumen **310**. In this manner, the pressure sensor **308** may be in direct contact with the fluid contained in the lumen **310** while not obstructing flow of the fluid through the lumen **310** even when the tubing **304** is bent or kinked. For example, when the tubing **304** is bent in a particular direction, one or more of the plurality of extensions from the main lumen area of the lumen **310** may be at least partially blocked, while fluid flow through another of the plurality of extensions may remain substantially unrestricted.

[0056] Moreover, it will be appreciated by one of ordinary skill in the art that many additional shapes, geometries, configurations, cross-sections, and/or combinations of the tubing **304**, the inner lumen **310**, and the pressure sensor **308** and/or additional components are possible, and all such are considered to be within the scope of the present invention.

[0057] Turning now to FIG. 4A, a cutaway view of placement of a pressure sensor **408** within an expanded portion of a tubing **404** is illustrated. In an example embodiment, the tubing **404** is

configured with a first thickness for a portion of the length of the tubing **404**. The tubing **404** is further configured with a second, larger thickness for another portion of the length of the tubing **404**. The pressure sensor **408** is disposed within the thicker portion of the tubing **404**, for example, in a "pocket" or other recess or cavity at least partially defined by the tubing **404**. Moreover, the pressure sensor **408** may be molded into the tubing **404** upon manufacture of the tubing **404**. The pressure sensor **408** may also be placed within a void, recess, pocket, or other available space at least partially defined by the tubing **404** subsequent to manufacture of the tubing **404**.

[0058] In an example embodiment illustrated in FIG. 4B, the pressure sensor **408** may be retained in the wall of the tubing **404** in connection with the use of a plug **412**. The plug **412** may be made of the same material as the tubing **404**. The plug **412** may also be made of a different material than the tubing **404**, for example, an incompressible material configured to frictionally couple to the material of the tubing **404**. The plug **412** may be at least partially inserted into and/or wedged between portions of the tubing **404**. In this manner, the pressure sensor **408** may be retained in a portion of the tubing **404**. The plug **412** may be removed as desired, for example, in order to replace a non-functioning pressure sensor **408**, or to upgrade the pressure sensor **408** to a new pressure sensor **408** having expanded functionality, extended communication range, or other desirable properties.

[0059] In another example embodiment illustrated in FIG. 4C, the pressure sensor **408** may be coupled to the tubing **404** at a joint, for example, a joint associated with a hard connector **414**. As illustrated, multiple portions of the tubing **404** are each configured with a wider portion having, for example, complementary cavities therein. The pressure sensor **408** is disposed within the complementary cavities of the tubing **404**,

and the ends of the tubing **404** are then brought together, such that the pressure sensor **408** is surrounded by the tubing **404**. One or more hard connector components **414** may similarly be coupled together, securing the pressure sensor **408** within the tubing **404**. Additionally, the expanded thickness of the tubing **404** near the hard connector **414** can confer additional stress relief to the tubing **404**.

[0060] FIGS. 5A and 5B illustrate configuration and operation of an exemplary pressure sensor according to an embodiment of the present invention. Referring to FIG. 5A, in an example embodiment, a pressure sensor **550** is hermetically sealed and comprises a housing **552**, for example, a metallic housing, and a membrane **554**, both of which may comprise titanium or other non-radioopaque material. The membrane **554** flexes in response to changes in pressure, which affects the pressure transducer **556**. Space inside the housing **552** may contain a pressure transfer medium **558**, for example, degassed silicone oil or other suitable incompressible pressure transfer medium. The pressure transfer medium **558** may at least partially surround and/or immerse various components within the housing **552**, for example, the pressure transducer **556**, a microcontroller **560** coupled to the pressure transducer **556**, a signal wire **562**, and/or the like. In an example embodiment, the surface area of membrane **554** is large in comparison to the volume of the pressure transfer medium occupying the interior of the housing **552**.

[0061] As pressure outside the pressure sensor **550** is increased, as illustrated in FIG. 5B, the membrane **554** deflects downward increasing the pressure of the pressure transfer medium **558**. Similarly, as pressure outside the pressure sensor **550** is decreased, the membrane **554** deflects a reduced amount, reducing the pressure on the pressure transfer medium **558**. The pressure transducer **556** converts pressure changes into changes in a suitable electromagnetic property, for example, capacitance,

inductance, resistance, and/or the like. The changes in the electromagnetic property are proportional to the changed in the measured pressure. The changes in the electromagnetic property are then detected by the microcontroller 560, for example, via periodic and/or continuous polling or other querying of the pressure transducer 556 by the microcontroller 560. The microcontroller 560 converts the signal from the pressure transducer 556, which may be an analog signal susceptible to noise, interference, and/or the like, into a suitable signal, for example, an analog or digital signal having a suitable signal to noise ratio, configured to be delivered to a remote location. In one example, a signal from the microcontroller 560 passes through the housing 552 via the signal wire 562 which may be configured to be substantially immune to typical levels of electrical noise. In another example, a signal from the microcontroller 560 may be wirelessly transmitted beyond the confines of the pressure sensor 550, for example, by an antenna or other components integrated with and/or coupled to the microcontroller 560.

[0062] The pressure sensor 550 may further comprise various components, for example, antennas, capacitors, inductors, transistors, electrical couplings, connectors, and/or the like, configured to permit the pressure sensor 550 to communicate with and/or receive operating power from a remote control, for example, remote controller unit 110. Such components may be located on and/or may comprise part of a microcontroller 560. Such components may also be coupled to the microcontroller 560 inside the housing 552. Such components may also be located on the outside of the housing 552, for example in order to facilitate wireless communication with the remote controller unit 110, or to facilitate wired and/or wireless communication with other components of a gastric banding system (e.g., other sensors, an access port, a pump, and/or the like).

[0063] With additional reference now to FIG. 5C, in an example embodiment the microcontroller **560** comprises an application specific integrated circuit (ASIC) having various memories, signal processors, communications components, power components, temperature sensors, and/or the like. The microcontroller **560** is configured to manage and/or condition incoming electrical power received from the remote controller unit **110**, for example via inductive coupling. The microcontroller **560** is further configured to utilize an internal temperature sensor to obtain temperature information. Responsive to temperature information, the microcontroller **560** may perform temperature compensation in order to adjust for changes in the behavior of one or more components of the pressure sensor **550**.

[0064] In various example embodiments, the microcontroller **560** stores calibration values associated with one or more components of the pressure sensor **550** in on-board memory on the microcontroller **560**. For example, one or more calibration values may be stored on the microcontroller **560** in order to correct for non-linear behavior and/or offsets associated with one or more components of the pressure sensor **550**, for example the pressure transducer **556**. The calibration values may be revised and/or updated, as suitable, in order to allow the pressure sensor **550** to report an accurate pressure reading to the remote controller unit **110**. Additionally, the microcontroller **560** may format pressure data, temperature data, and/or other data for transmission to the remote controller unit **110**. Moreover, the microcontroller **560** may be configured to respond as a slave to a master unit, for example another microcontroller **560** in another pressure sensor **550**, a microprocessor in the remote controller unit **110**, and/or the like.

[0065] In an example embodiment, the microcontroller **560** comprises an ASIC having a form factor of about 1.5mm by 3.15mm

by 0.2mm. In other example embodiments, the microcontroller may have a larger and/or smaller form factor, in order to allow the microcontroller **560** to be placed within the pressure sensor **550** and/or immersed in the pressure transfer medium **558** therein.

[0066] The pressure sensor **550** is configured to withstand high temperatures, for example, temperatures in excess of temperatures necessary for steam sterilization (e.g., temperatures in excess of 120 degrees Celsius), without damage to the pressure transducer **556** or other components of the pressure sensor **550** caused by expansion of the pressure transfer medium **558**. Notably, the pressure sensor **550** achieves this result without resorting to fillers intended to lower the overall thermal expansion coefficient of the pressure transfer medium **558**, for example, fillers comprising glass beads, metal fragments, and/or the like, as such fillers can lead to undesirable increases in manufacturing complexity and/or cost. Additionally, the pressure sensor **550** minimizes the internal volume which is filled with the pressure transfer medium **558** while maximizing the surface area of the membrane **554**. This design minimizes the stress on the membrane for a given increase in the temperature of the sensor **550**. Moreover, because the pressure sensor **550** receives operational power from the remote controller unit **110**, no battery or other implanted power source is required for operation of the pressure sensor **550**.

[0067] The pressure sensor **550** in accordance with various exemplary embodiments may comprise a pressure sensor, multiple pressure sensors, including multiple pressure sensors configured to operate in a differential mode, a flow rate sensor, and/or the like or combinations thereof.

[0068] Returning again to FIG. 1B, the gastric banding system **100B** may comprise a plurality of the pressure sensors **108** disposed, for example, within the tubing **104**. In an exemplary embodiment, two pressure sensors **108** are situated within the

high precision pump unit **114**. During a filling or draining condition, as well as during a no-flow condition, both of the pressure sensors **108** may be used to measure pressure, thereby providing the benefits of redundancy and averaging. Moreover, any suitable number of the pressure sensors **108** may be utilized.

[0069] The systems and apparatus described herein further include the remote controller unit **110** (not shown), which provides access to system data and functions. The remote controller unit **110** may be an external, handheld, reusable battery-powered device, or any other suitable electronic device. The remote controller unit **110** can be made of any rugged material, including polypropylene, cycloolephin co-polymer, nylon, and other compatible polymers and the like. The remote controller unit **110** is not implanted within the patient, so hermetic sealing of the unit is not required. However, the remote controller unit **110** is preferably at least water resistant, if not waterproof, and may be cleaned using standard hospital disinfectants without damage to the unit.

[0070] Further, the remote controller unit **110** is configured with a user interface including at least one display and at least one user input. In some example embodiments, the display and the user input are combined in the form of a touch screen with a color display. In other embodiments, the display is grayscale. The remote controller unit **110** permits a clinician or a patient to interact with the gastric banding system **100B**, for example, by navigating through menu driven screens used for data entry, data collection, and control of other components of the gastric banding system **100B**.

[0071] The remote controller unit **110** is capable of communicating with the pressure sensor **108**, the high precision pump unit **114**, and/or other components of a gastric banding system, for example, the gastric banding system **100B**. "Capable of communicating" as used herein refers to the ability of the

remote controller unit **110** to establish communications with other components, yet still have the ability to break communication and the systems described herein still function. To establish communication, in one example embodiment, once the remote controller unit **110** is initialized, a display shows a searching query for nearby compatible components, for example, the high precision pump unit **114**, the pressure sensor **108**, and/or the like. As the remote controller unit **110** is brought into range of a compatible component, a symbol displays the strength of the communication link. Once stable communications have been acquired, the display may show the serial number or other identifying indicia of the component or system so a clinician can verify they have the appropriate patient records in hand.

**[0072]** Via the remote controller unit **110**, the clinician can obtain information from and/or issue commands to other components of the gastric banding system. For example, if the patient requires a tightening of the gastric band **106**, the clinician can enter the amount of the desired volume increase. If the patient requires a loosening of the gastric band **106**, the clinician can enter the amount of the desired volume decrease. Current and/or logged pressure readings from the pressure sensor **108** may similarly be obtained. The remote controller unit **110** can also display the current and/or desired volume within the gastric band **106** and indicate the new volume as the gastric band **106** fills or drains.

**[0073]** To verify an appropriate adjustment has been made to the system, the clinician can set the remote controller unit **110** into a pressure monitor mode and request that the patient drink water. The display may show a real time graph of one or more pressure readings measured within the gastric banding system **100B**, for example, by one or more of the pressure sensors **108**.

This diagnostic tool may show higher pressures and warning messages if the gastric band **106** has been over-tightened.

**[0074]** The remote controller unit **110** can synchronize and charge when coupled with a charging cradle or docking station. This docking station provides the ability to recharge a battery for the remote controller unit **110**, and may also provide a link to download information to a personal computer such as the adjustment history of a patient. Other data that can be stored on the remote controller unit **110** and downloaded from the high precision pump unit **114** and/or the pressure sensor **108** includes, but is not limited to, serial number, gastric band size, patient information, gastric band volume, current pressure, historical pressure, firmware version and patient adjustment history. This data can be downloaded directly to a patient tracking database for ease of tracking.

**[0075]** Any data stored on the remote controller unit **110**, on the pressure sensor **108**, and/or on the high precision pump unit **114** can be electronically secured. In other words, security measures can be put in place to keep the data confidential, including communication between the high precision pump unit **114** and the remote controller unit **110**, communication between the high precision pump unit **114** and the pressure sensor **108**, and/or other communications between various components of the gastric banding system **100B**. Security measures can include computer generated algorithms that prevent intrusion by outside parties.

**[0076]** In an example embodiment, the pressure sensor **108** is a passive device configured to be powered by and/or communicate with the remote controller unit **110** when it is in close proximity. For example, in one example embodiment, the remote controller unit **110** may be configured to power and communicate with the pressure sensor **108** at a distance less than about 8 inches, preferably less than about 4 inches (about 10.2 cm) of tissue plus about 4 inches, preferably about 2 inches (about 5.1

cm) of air. Moreover, power and communications can be tailored to transmit over longer distances, or can be tailored to have the remote controller unit **110** placed on the skin adjacent to the pressure sensor **108**.

[0077] The remote controller unit **110** can inductively power and telemetrically control the pressure sensor **108**. The remote controller unit **110** may be configured to provide continuous power to the pressure sensor **108**. In an example embodiment, a dedicated microcontroller within the remote controller unit **110** monitors the amount of power that is transmitted. Further, a power management system may be implemented to optimize energy transmission between the remote controller unit **110** and the pressure sensor **108** relative to their separation distance. For example, the power transmission may automatically decrease as the remote controller unit **110** is moved closer to the pressure sensor **108**, and may be increased as the distance is increased. This reduces wasted energy, and energy exposure to the patient.

[0078] Returning to FIGS. 5A and 5B, in an example embodiment, the pressure sensor **550** is a passive device which may be entirely controlled and powered by the remote controller unit **110**. An antenna on the microcontroller **560** housed within the pressure sensor **550** couples to the remote controller unit **110** to allow the transmission of power through the skin and/or subcutaneous tissue. In another embodiment, the antenna providing power is located outside of the pressure sensor **550**. The power issued from the remote controller unit **110** may be continually monitored by a dedicated microprocessor to ensure that power transmission is suitably reduced and/or minimized to the lowest level required for operation. To reduce the power transmission and to improve command communication, the pressure sensor **108** and the remote controller unit **110** may have a channel frequency dedicated to command communication and a separate channel frequency dedicated to power transmission. The command

communication can be configured, for example, to take place at about 402 - 406 MHz while the power transmission, for example, takes place at about 400 kHz. This command communication adheres to the frequency and power standards set by the Medical Implant Communications Service. Other communication and/or power frequency ranges may be utilized, as desired. To ensure accuracy, communication and control commands may be verified prior to data reporting or command implementation, for example, by error checking and/or correction algorithms.

**[0079]** The systems and apparatus described herein use common surgical techniques to place the components in their respective positions within a patient. The surgical techniques may be identical or similar to those used in the placement of conventional gastric banding systems. For example, the gastric band **106** may be placed around the stomach using laparoscopic techniques, as known to those of skill in the art. Like a conventional access port, the high precision pump unit **114** and/or the access port **102** may be sutured onto the rectus muscle sheath or any other conveniently accessible muscle. For example, in order to achieve a secure attachment of the high precision pump unit **114**, it may be sutured to the rectus muscle and remain securely attached for forces below about 6 pound-force (about 26.6 Newtons), and preferably below about 3 pound-force (about 13.3 Newtons). The tubing **104** passes through the rectus muscle into the peritoneal cavity.

**[0080]** The systems and apparatus of the present invention further allow for remotely monitored pressure and controlled adjustment without needles, non-invasively, by using the remote controller unit **110**. Also, should the remote controller unit **110** be unavailable, damaged, out of power, or in the event of an emergency, an adjustment of the gastric band **106** can be performed invasively using a needle. For example, by using the access port **102** illustrated in FIGS. 1A and 1B, a clinician can

choose to use a standard needle for adjustments. If any of the electronics associated with the systems and apparatus described herein become inoperable, the access port **102** can be used to add or remove the fluid from the gastric band **106**. The access port **102** and a syringe or needle can be used to adjust the gastric band **106**.

**[0081]** The systems described herein generally function as follows. A clinician uses the remote controller unit **110** to query one or more of the pressure sensors **108**. The pressure sensors **108** are activated responsive to an energy pulse from the remote controller unit **110**. The pressure sensors **108** may then take pressure readings, store pressure values or other information, and/or transmit current and/or historical pressure values or other information to the remote controller unit **110**. Updated configuration information, command information, control information, diagnostic information, reset information, and/or other suitable information may be sent to and/or from the remote controller unit **110** and the pressure sensor **108**. Responsive to information from the pressure sensor **108** and/or other suitable information or operating parameters, the remote controller unit **110** may subsequently and/or simultaneously communicate with and/or power the high precision pump unit **114** in order to adjust the gastric band **106**. In an example embodiment, the remote controller unit **110** communicates simultaneously with the pressure sensor **108** and the high precision pump unit **114** in order to monitor pressure changes in the gastric banding system during filling and/or draining of the gastric band **106**. In one example, the total power consumed by the pressure sensor **108**, the high precision pump unit **114**, and all other inductively powered components of gastric banding system **100B** during simultaneous operation thereof is less than 1 watt. In another example, the total power consumed is less than 700 milliwatts.

**[0082]** As described herein, the present systems and apparatus may be compatible with magnetic resonance imaging (MRI), which is much safer for a patient than exposure to X-ray radiation. In one example embodiment, the systems and apparatus described herein are configured and structured to be compatible with MRI, or MRI safe, at magnetic field strengths of up to about 1.5 Tesla. For example, the pressure sensor **108** may be entirely inductively powered. The pressure sensor **108** may utilize no permanent magnets, no long metallic wires or leads, and a minimal or negligible amount of ferrous or ferromagnetic material. The pressure sensor **108** may be substantially free of or contain substantially no ferromagnetic materials. Substantially no ferromagnetic materials refers to materials containing less than about 5%, preferably less than about 1% or 0.1% (w/w) of ferromagnetic material. The resulting systems are thus MRI safe given standard specifications regulating translational and rotational attraction, MRI heating, and imaging artifacts. All materials selected for the systems are preferably selected to be compatible and safe in an MRI environment.

**[0083]** Further, the inductive powering of the pressure sensor **108** utilizes energy passed through the body tissue. Since the body tissue absorbs a portion of the energy passing through it, the heating of the body tissue can be proportional to the total energy transferred. To ensure that the systems meet standards to minimize tissue heating (below 2°C above body temperature per ISO 45502), the pressure sensors **108** described herein have been designed to use very little power to measure pressure within the system, for example, less than about 2 milliwatts, or preferably less than about 1.35 milliwatts, and do not cause excessive heating of the patient's body tissue.

**[0084]** Using the remote controller unit **110** to communicate with the pressure sensor **108**, a clinician can monitor pressure inside

the gastric band **106**, for example, in "real time" during an adjustment of the constriction within the gastric band **106**. This allows the clinician to observe the response of the gastric band **106** to a patient's adjustment. A new modality for gastric band adjustment management is thus enabled, because clinicians can monitor static pressure, as well as pressure and volumes during adjustments. With these pressure sensing capabilities, the clinician can make expanded determinations, for example, whether there is a leak within the system (e.g., an unexpectedly low, declining, or zero pressure reading), or whether there is an obstruction in the system (e.g., an unexpectedly high pressure reading or prolonged pressure rise).

**[0085]** In one example embodiment of the present invention, components of the systems can be replaced without replacing the entire system and subjecting patients to overly invasive surgeries to replace entire systems when a single component is defective or damaged. For example, if the pressure sensor **108** becomes damaged, unreliable, or inoperable, it can be replaced independently of other components. Additionally, if multiple pressure sensors **108** are used, the system can continue to operate with a reduced number of operational pressure sensors **108** should one or more of the pressure sensors **108** fail.

**[0086]** The systems described herein are configured to meet at least one safety specification. For example, in the event of any failure of the systems, either no change in the gastric band **106** tightness or a loosening of the gastric band **106** results. Further, the high precision pump unit **114** and the pressure sensor **108** are biocompatible for long term implantation, and the remote controller unit **110** is biocompatible for transient use both per ISO 10993. The systems are designed to have no significant interaction or interference with other electronics in any of the following modalities: implantable energy sources such as defibrillators and pacemakers; internal energy sources

such as electrosurgical instruments; external energy sources such as ultrasound, x-rays and defibrillators; and radiofrequency signals such as pacemaker programmers and neuron-stimulators.

**[0087]** Sensing or measuring the pressure within a gastric banding system, for example within the fluid pathway of the gastric banding system **100B**, provides diagnostic uses. Clinicians can measure pressure while a patient drinks water, recording and analyzing resulting pressure fluctuations which can help determine if the gastric band **106** is too restrictive. A band that is too restrictive can also be confirmed by the patient's response (generally discomfort) upon drinking the water, and can then be appropriately adjusted. Further, sensing or measuring pressure in the gastric banding system **100B** can be useful in diagnosing system leaks or obstructions. For example, if the pressure consistently drops over an extended period of time, the clinician can diagnose a leak within the system and plan for an appropriate treatment to fix the problem. In contrast, if there is an obstruction within the system with a sustained pressure rise over time, the clinician can diagnose an obstruction within the system and plan for an appropriate treatment to fix the problem.

**[0088]** The pressure sensor **108** may be utilized on a short term basis and/or a long term basis. For example, the pressure sensor **108** may be utilized during the course of a patient visit with a clinician, which may be anywhere from a few minutes to several hours in duration. Information from the pressure sensor **108** may be used to analyze changes in pressure which occur during various intentional patient actions, for example, swallowing. Information from the pressure sensor **108** may also be used to detect unintentional patient actions, for example, smooth muscle fasciculations, reflexive actions, spasming, cramping, and/or the like.

[0089] On a longer term basis, the pressure sensor **108** may also be used, for example, to compare pressure readings from one clinical visit to the next, from one year to the next, and/so on. Long-term changes in pressure reported by the pressure sensor **108** may be utilized to detect system leaks, capsular contraction around the stomach, herniation and/or erosions within the stomach, and/or the like. In this manner, the pressure sensor **108** can provide additional information to enable the clinician to determine a suitable course of care for the patient.

[0090] Moreover, the pressure sensor **108** may also be retrofitted to an existing gastric banding system. For example, an existing gastric banding system may be configured with tubing lacking a pressure sensor **108**. A minor surgical procedure may replace at least a portion of the existing tubing with the new tubing **104** having one or more pressure sensors **108** therein. Thus, pressure monitoring capabilities can be extended to existing patients without requiring removal and/or replacement of various existing components of their gastric banding systems, for example access ports, gastric bands, pumps, batteries, valves, and/or the like.

[0091] Unless otherwise indicated, all numbers expressing quantities of ingredients, properties such as molecular weight, reaction conditions, and so forth used in the specification and claims are to be understood as being modified in all instances by the term "about." Accordingly, unless indicated to the contrary, the numerical parameters set forth in the specification and attached claims are approximations that may vary depending upon the desired properties sought to be obtained by the present invention. At the very least, and not as an attempt to limit the application of the doctrine of equivalents to the scope of the claims, each numerical parameter should at least be construed in light of the number of reported significant digits and by applying ordinary rounding techniques.

Notwithstanding that the numerical ranges and parameters setting forth the broad scope of the invention are approximations, the numerical values set forth in the specific examples are reported as precisely as possible. Any numerical value, however, inherently contains certain errors necessarily resulting from the standard deviation found in their respective testing measurements.

**[0092]** The terms "a," "an," "the" and similar referents used in the context of describing the invention (especially in the context of the following claims) are to be construed to cover both the singular and the plural, unless otherwise indicated herein or clearly contradicted by context. Recitation of ranges of values herein is merely intended to serve as a shorthand method of referring individually to each separate value falling within the range. Unless otherwise indicated herein, each individual value is incorporated into the specification as if it were individually recited herein. All methods described herein can be performed in any suitable order unless otherwise indicated herein or otherwise clearly contradicted by context. The use of any and all examples, or exemplary language (e.g., "such as") provided herein is intended merely to better illuminate the invention and does not pose a limitation on the scope of the invention otherwise claimed. No language in the specification should be construed as indicating any non-claimed element essential to the practice of the present invention.

**[0093]** Groupings of alternative elements or embodiments of the present invention disclosed herein are not to be construed as limitations. Each group member may be referred to and claimed individually or in any combination with other members of the group or other elements found herein. It is anticipated that one or more members of a group may be included in, or deleted from, a group for reasons of convenience and/or patentability. When any such inclusion or deletion occurs, the specification is

deemed to contain the group as modified thus fulfilling the written description of all Markush groups used in the appended claims.

**[0094]** Certain embodiments of this invention are described herein, including the best mode known to the inventors for carrying out the present invention. Of course, variations on these described embodiments will become apparent to those of ordinary skill in the art upon reading the foregoing description. The inventor expects skilled artisans to employ such variations as appropriate, and the inventors intend for the invention to be practiced otherwise than specifically described herein. Accordingly, this invention includes all modifications and equivalents of the subject matter recited in the claims appended hereto as permitted by applicable law. Moreover, any combination of the above-described elements in all possible variations thereof is encompassed by the invention unless otherwise indicated herein or otherwise clearly contradicted by context.

**[0095]** Furthermore, numerous references have been made to patents and printed publications throughout this specification. Each of the above-cited references and printed publications are individually incorporated herein by reference in their entirety.

**[0096]** Specific embodiments disclosed herein may be further limited in the claims using consisting of or and consisting essentially of language. When used in the claims, whether as filed or added per amendment, the transition term "consisting of" excludes any element, step, or ingredient not specified in the claims. The transition term "consisting essentially of" limits the scope of a claim to the specified materials or steps and those that do not materially affect the basic and novel characteristic(s). Embodiments of the present invention so claimed are inherently or expressly described and enabled herein.

[0097] In closing, it is to be understood that the embodiments of the present invention disclosed herein are illustrative of the principles of the present invention. Other modifications that may be employed are within the scope of the present invention. Thus, by way of example, but not of limitation, alternative configurations of the present invention may be utilized in accordance with the teachings herein. Accordingly, the present invention is not limited to that precisely as shown and described.

**CLAIMS****WHAT IS CLAIMED IS:**

1. An implantable device that monitors static and fluctuating pressure levels of a fluid moving to and from an inflatable portion of a gastric band, the implantable device comprising:
  - a housing defining a cavity and having an open top portion;
  - a flexible membrane covering the open top portion of the housing and having an inner surface facing the cavity and an outer surface capable of contacting the fluid;
  - a pressure transfer fluid located within the cavity;
  - a sensing element, positioned within the cavity of the housing and positioned adjacent to the flexible membrane, for measuring a pressure on the flexible membrane, the pressure being caused by the fluid contacting the outer surface of the flexible membrane, for converting the pressure to a pressure signal; and
  - a microcontroller positioned within the cavity of the housing and coupled to the sensing element, the microcontroller configured to process the pressure signal received from the sensing element and transmit the processed pressure signal to a location external to the implantable device.
2. The implantable device of claim 1, wherein the sensing element is selected from a group consisting of a pressure sensor, two pressure sensors configured to operate in a differential mode, a flow rate sensor, and combinations thereof.
3. The implantable device of claim 1, wherein the pressure transfer fluid is degassed silicone oil.
4. The implantable device of claim 1, wherein the sensing element is immersed in the pressure transfer fluid.

5. The implantable device of claim 1, wherein the flexible membrane moves toward the sensing element when the fluid applies pressure to the outer surface of the flexible membrane.
6. The implantable device of claim 1, further comprising a remote device, wherein the remote device is configured to receive the pressure signal transmitted by the microcontroller, and wherein the remote device wirelessly provides power for operation of the implantable device.
7. The implantable device of claim 1, wherein the remote device receives the pressure signal from the microcontroller and displays the pressure signal on a display component of the remote device.
8. The implantable device of claim 1, wherein the pressure on the flexible membrane changes an electrical property of the sensing element.
9. The implantable device of claim 8, wherein the electrical property is detected by periodic or continuous polling of the sensing element by the microcontroller.
10. The implantable device of claim 1, wherein the pressure transfer fluid contains no fillers having a negative coefficient of thermal expansion.
11. The implantable device of claim 1, wherein the implantable device is configured to withstand steam sterilization without damage to the sensing element.

12. The implantable device of claim 1, wherein the implantable device is configured to withstand a temperature in excess of 120 degrees Celsius without damage to the sensing element.

13. An implantable device that monitors a pressure of fluid within an inflatable portion of a gastric band, the implantable device comprising:

a tube defining a lumen and having a first end and a second end, the second end connected to the inflatable portion of the gastric band for allowing the fluid to flow through the lumen; and

a pressure sensor positioned within at least one of the lumen or the tube,

wherein the pressure sensor is configured to sense the pressure of the fluid within the inflatable portion of the gastric band,

wherein the pressure sensor is configured to transmit a pressure signal based on the pressure to a microcontroller,

wherein the pressure sensor comprises a rigid housing conferring strain relief upon at least a portion of the tube, and

wherein the pressure sensor shields at least a portion of the tube from puncture by a needle.

14. The implantable device of claim 13, wherein the pressure sensor comprises:

a housing defining a cavity and having an open top portion;

a flexible membrane covering the open top portion of the housing and having an inner surface facing the cavity and an outer surface capable of contacting the fluid;

a pressure transfer fluid located within the cavity;

a sensing element, positioned within the cavity of the housing and positioned adjacent to the flexible membrane, for measuring a pressure on the flexible membrane, the pressure

being caused by the fluid contacting the outer surface of the flexible membrane, for converting the pressure to a pressure signal; and

a microcontroller positioned within the cavity of the housing and coupled to the sensing element, the microcontroller configured to process the pressure signal received from the sensing element and transmit the processed pressure signal to a location external to the implantable device.

15. The implantable device of claim 13, further comprising an access port, coupled to the first end of the tube, for adding or removing the fluid from the inflatable portion of the gastric band.

16. The implantable device of claim 13, further comprising a pump, coupled to the first end of the tube, for adding fluid or removing fluid from the inflatable portion of the gastric band.

17. The implantable device of claim 13, further comprising a reservoir, coupled to the pump, for holding fluid added to or removed from the inflatable portion of the gastric band.

18. The implantable device of claim 13, wherein the pressure sensor draws less than 2 milliwatts of power during operation.

19. The implantable device of claim 13, wherein the remote control device provides power to the pressure sensor.

20. The implantable device of claim 13, wherein the remote control device requests pressure sensor readings from the pressure sensor and displays the pressure sensor readings.

21. The implantable device of claim 19, wherein the remote control device includes a memory for storing the pressure sensor readings.

22. The implantable device of claim 19, wherein the pressure sensor readings can be used to detect an event selected from a group comprising: a movement of the gastric band, capsular contraction around the gastric band, a patient action, a leak of the fluid, an erosion within a stomach, a herniation of a stomach, a smooth muscle fasciculation, a reflexive muscle action, a muscle spasm, a muscle cramp, and combinations thereof.

23. The implantable device of claim 13, wherein the pressure sensor is disposed in the lumen, and wherein the lumen comprises a plurality of extensions configured to allow the fluid to pass by the pressure sensor in the event of kinking of the tube.

24. The implantable device of claim 13, wherein the tube has a cross section of at least one of a circle, an oval, an egg shape, a bullet shape, a rectangle, and a rounded conical frustum.

25. The implantable device of claim 13, wherein the pressure sensor shields at least a portion of the tube from puncture by a needle by virtue of the pressure sensor comprising a puncture-resistant material.

26. The implantable device of claim 25, wherein the puncture resistant material is a titanium housing of the pressure sensor.

27. The implantable device of claim 13, wherein the pressure sensor shields at least a portion of the tube from puncture by a needle by virtue of the pressure sensor being disposed between the lumen and the skin of a patient.

28. The implantable device of claim 13, wherein the tube comprises at least two portions.

29. The implantable device of claim 28, wherein the at least two tube portions are coupled with at least one hard connector, and wherein the at least one hard connector confers strain relief upon the tube.

30. The implantable device of claim 13, wherein the pressure sensor is disposed within a first portion of the tube wall that is thicker than a second portion of the tube wall absent a pressure sensor.

31. The implantable device of claim 30, wherein the thicker portion of the tube wall confers strain relief upon the tube.

32. The implantable device of claim 13, wherein the implantable device is retrofittable to an access port already surgically implanted in a patient.

33. The implantable device of claim 13, wherein the pressure sensor is operative free from interference from other mechanical and electrical components contained in one or more of an access port, a pump, or a valve coupled to the gastric band.

34. A system for facilitating obesity control, the system comprising:

an implantable gastric banding device including an inflatable member for containing fluid and restricting a patient's cardia;

an implantable access port coupled to the implantable gastric banding device via a tubing, the implantable access port controlling pressure within the inflatable member;

an external remote control device capable of communicating with and powering a pressure sensor; and

the pressure sensor disposed at least partially within the tubing, the pressure sensor comprising:

a housing defining a cavity and having an open top portion;

a flexible membrane covering the open top portion of the housing and having an inner surface facing the cavity and an outer surface capable of contacting a fluid within the tubing;

a pressure transfer fluid located within the cavity

a sensing element, positioned within the cavity of the housing and positioned adjacent to the flexible membrane, for measuring a pressure on the flexible membrane, the pressure being caused by the fluid contacting the outer surface of the flexible membrane, for converting the pressure to a pressure signal; and

a microcontroller positioned within the cavity of the housing and coupled to the sensing element, the microcontroller configured to process the pressure signal received from the sensing element and transmit the processed pressure signal to a location external to the implantable device.

35. The system of claim 34, wherein the pressure sensor is disposed in a lumen within the tubing, and wherein the lumen is configured with a plurality of extensions configured to allow the fluid to pass by the pressure sensor in the event of kinking of the tube.

36. The system of claim 34, wherein the tube has a cross section of at least one of a circle, an oval, an egg shape, a bullet shape, a rectangle, and a rounded conical frustum.

37. The system of claim 34, wherein the pressure sensor is disposed between the lumen and the skin of a patient, and wherein the pressure sensor shields at least a portion of the

tubing from puncture by a needle by virtue of the pressure sensor comprising a puncture-resistant material.

38. The system of claim 34, wherein the pressure transfer fluid contains no fillers having a negative coefficient of thermal expansion.

39. The system of claim 34, wherein the pressure sensor is configured to withstand steam sterilization without damage to the sensing element.

40. The system of claim 34, wherein the pressure sensor is configured to withstand a temperature in excess of 120 degrees Celsius without damage to the sensing element.

41. A system for facilitating obesity control, the system comprising:

- an implantable gastric banding device including an inflatable member for containing fluid and restricting a patient's cardia;

- an implantable fluid reservoir;

- an implantable pump unit for controlling pressure within the inflatable member, wherein the implantable pump unit is in communication with the fluid reservoir and the gastric banding device via a tubing;

- an implantable access port coupled to the implantable pump unit;

- an external remote control device capable of communicating with and powering the implantable pump unit and a pressure sensor; and

- the pressure sensor positioned within the implantable pump unit, the pressure sensor comprising:

- a housing defining a cavity and having an open top portion;

a flexible membrane covering the open top portion of the housing and having an inner surface facing the cavity and an outer surface capable of contacting a fluid within the tubing;

a pressure transfer fluid located within the cavity;

a sensing element, positioned within the cavity of the housing and positioned adjacent to the flexible membrane, for measuring a pressure on the flexible membrane, the pressure being caused by the fluid contacting the outer surface of the flexible membrane, for converting the pressure to a pressure signal; and

a microcontroller positioned within the cavity of the housing and coupled to the sensing element, the microcontroller configured to process the pressure signal received from the sensing element and transmit the processed pressure signal to a location external to the implantable device.

42. The system of claim 41, wherein the tubing comprises at least two tubing portions, wherein the at least two tubing portions are coupled with at least one hard connector, and wherein the at least one hard connector confers strain relief upon the tubing.

43. The system of claim 41, wherein the pressure sensor is disposed between a lumen within the tubing and the skin of a patient, and wherein the pressure sensor shields at least a portion of the tubing from puncture by a needle by virtue of the pressure sensor comprising a puncture-resistant material.

44. The system of claim 41, wherein the pressure transfer fluid contains no fillers having a negative coefficient of thermal expansion.

45. The system of claim 41, wherein the pressure transfer fluid contains no fillers having a coefficient of thermal expansion

lower than the coefficient of thermal expansion of the pressure transfer fluid.

46. The system of claim 41, wherein the pressure sensor is configured to withstand steam sterilization without damage to the sensing element.

47. The system of claim 41, wherein the pressure sensor is configured to withstand a temperature in excess of 120 degrees Celsius without damage to the sensing element.

48. A method of retrofitting a tubing-based pressure sensor to a previously implanted gastric banding system, the method comprising:

- removing a portion of existing tubing from the gastric banding system;

- inserting a portion of new tubing into the gastric banding system, wherein the portion of the new tubing contains at least one pressure sensor disposed at least partially therein, and wherein the pressure sensor comprises:

- a housing defining a cavity and having an open top portion;
- a flexible membrane covering the open top portion of the housing and having an inner surface facing the cavity and an outer surface capable of contacting a fluid within the tubing;
- a pressure transfer fluid located within the cavity;
- a sensing element, positioned within the cavity of the housing and positioned adjacent to the flexible membrane, for measuring a pressure on the flexible membrane, the pressure being caused by the fluid contacting the outer surface of the flexible membrane, for converting the pressure to a pressure signal; and

- a microcontroller positioned within the cavity of the housing and coupled to the sensing element, the microcontroller configured to process the pressure signal received from the

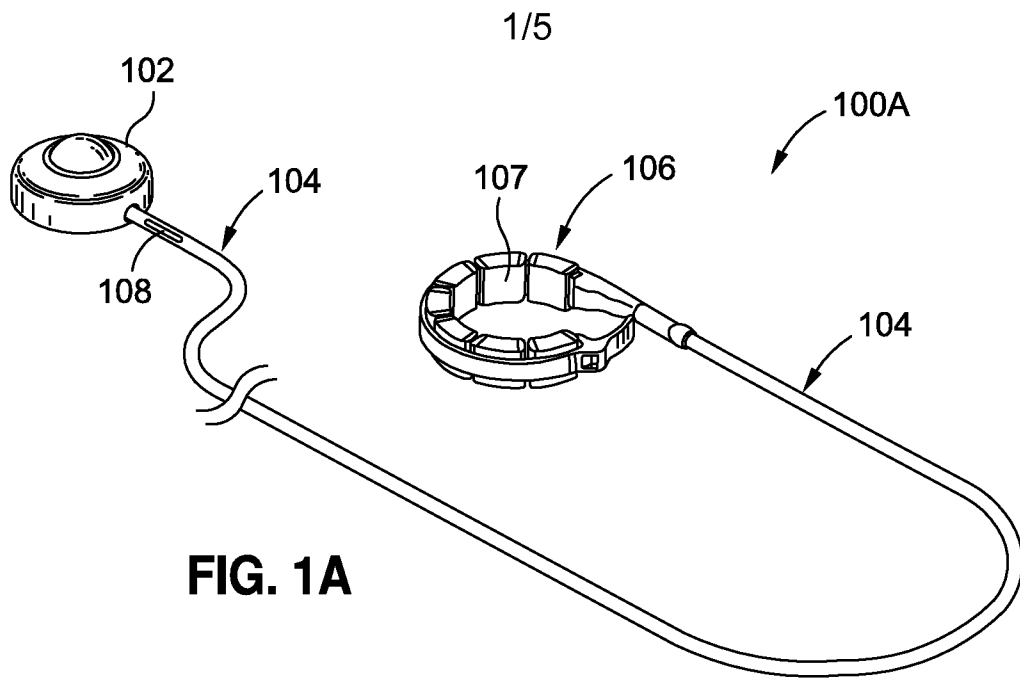
sensing element and transmit the processed pressure signal to a location external to the pressure sensor; and

coupling the portion of the new tubing to at least one of: a previously implanted access port, a previously implanted pump, or a portion of the existing tubing.

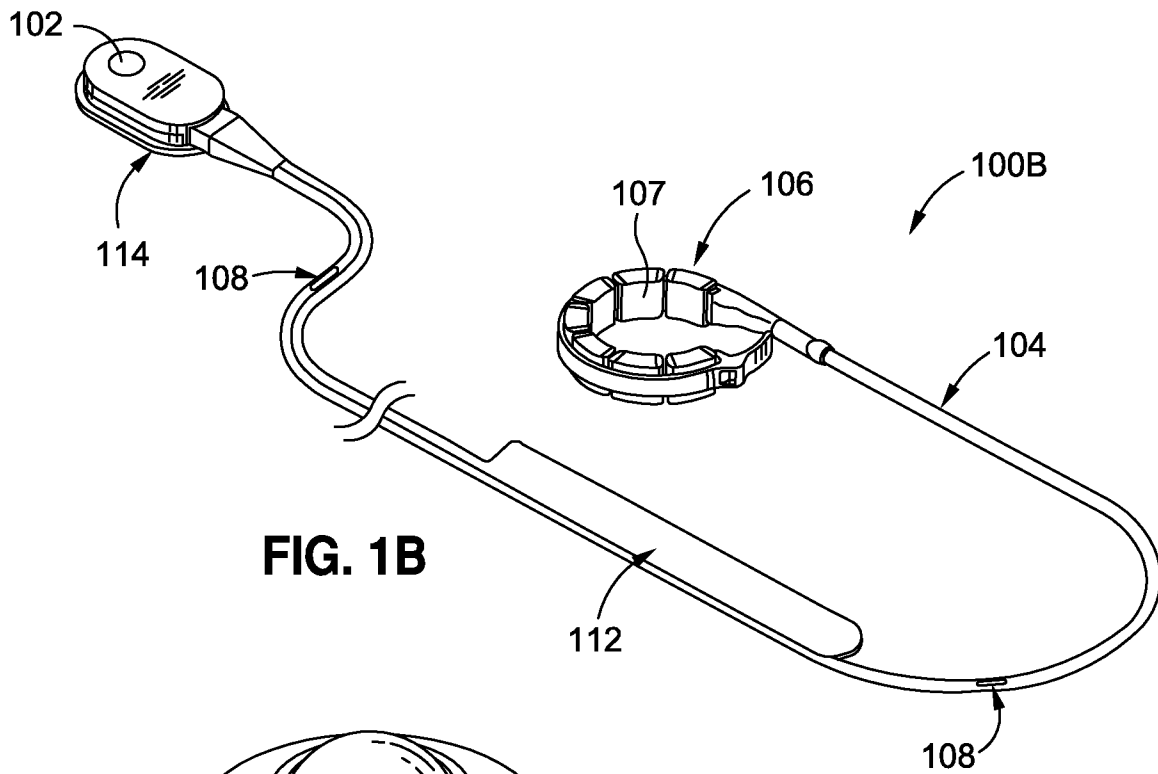
49. The method of claim 48, wherein the pressure sensor is disposed between a lumen within the portion of new tubing and the skin of a patient, and wherein the pressure sensor shields at least a portion of the new tubing from puncture by a needle by virtue of the pressure sensor comprising a puncture-resistant material.

50. The method of claim 48, wherein the pressure sensor is configured to withstand steam sterilization without damage to the pressure sensor.

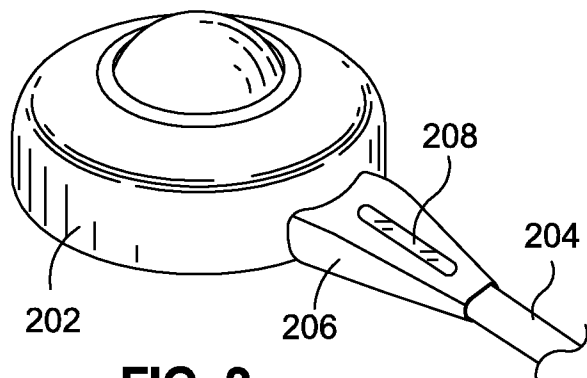
51. The method of claim 48, wherein the steam sterilization is conducted at a temperature in excess of 120 degrees Celsius.



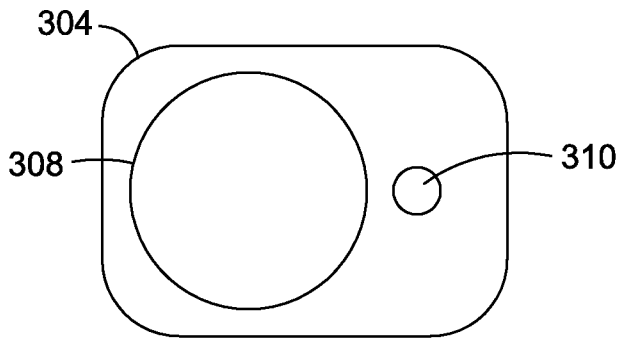
**FIG. 1A**



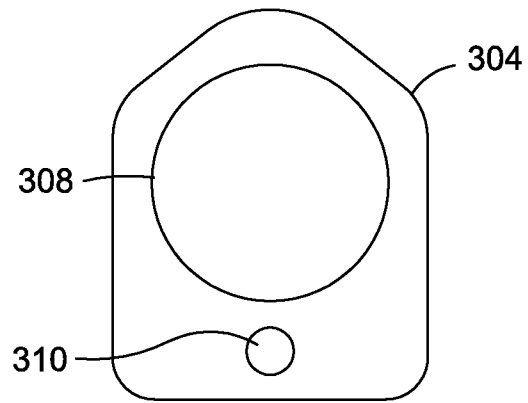
**FIG. 1B**



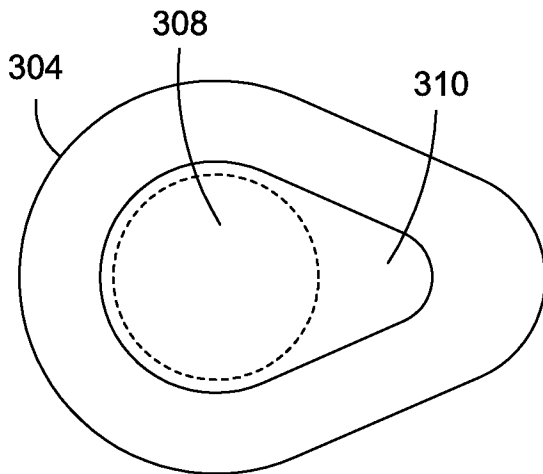
**FIG. 2**



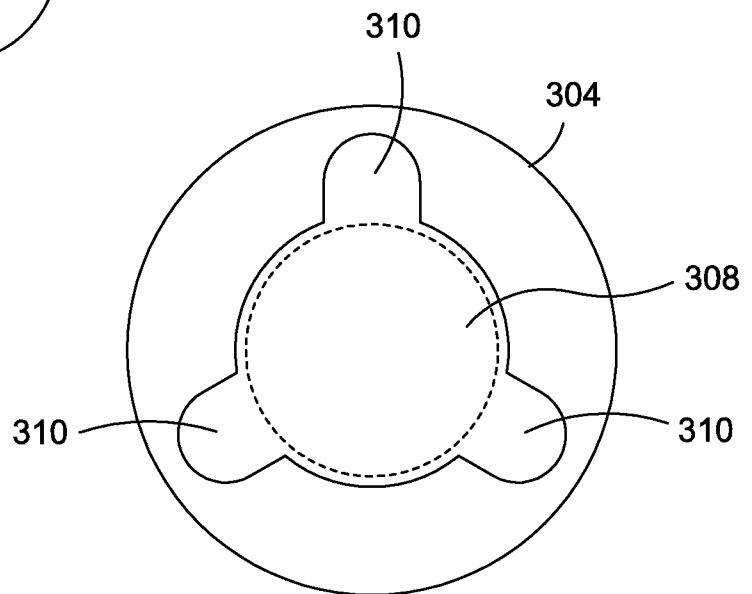
**FIG. 3A**



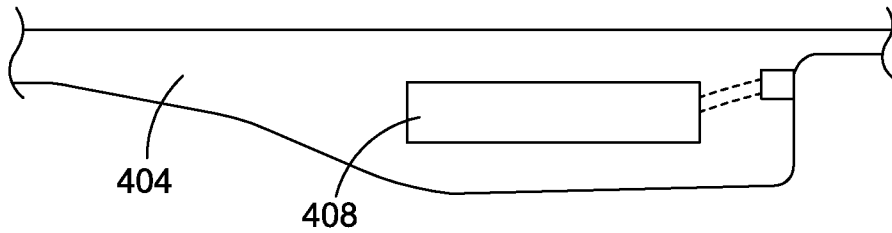
**FIG. 3B**



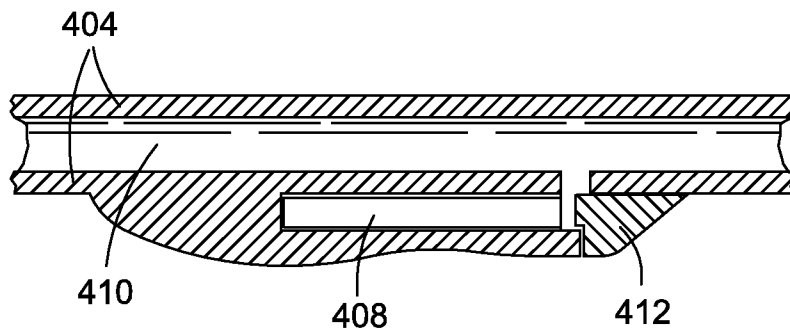
**FIG. 3C**



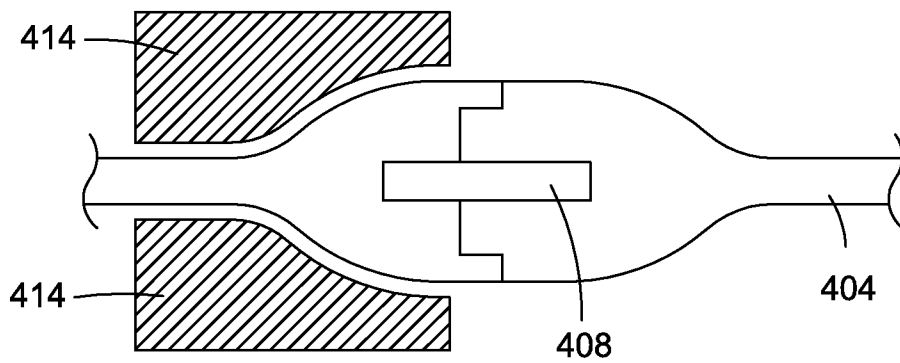
**FIG. 3D**



**FIG. 4A**

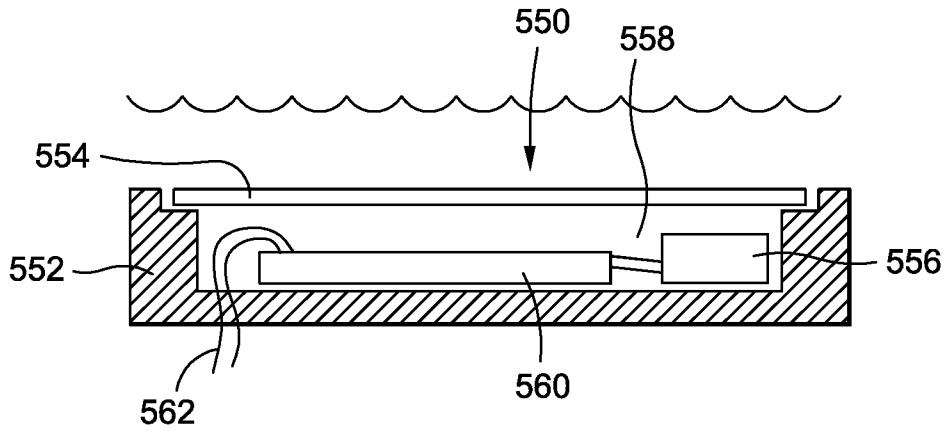


**FIG. 4B**

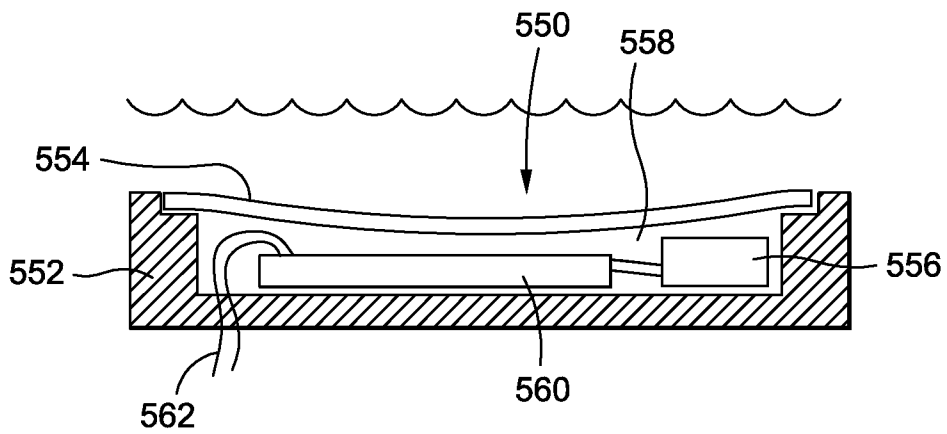


**FIG. 4C**

4/5



**FIG. 5A**



**FIG. 5B**

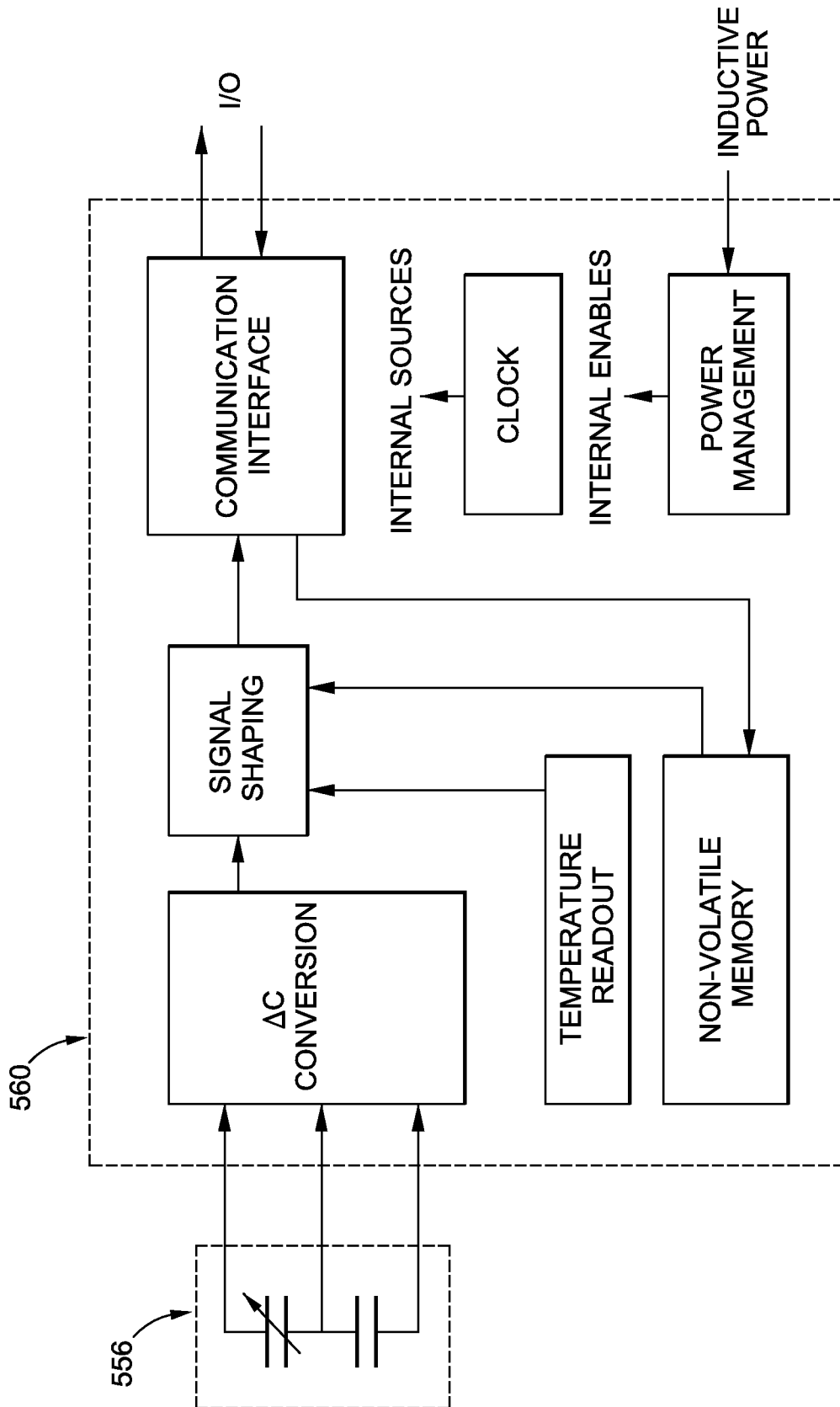


FIG. 5C

**INTERNATIONAL SEARCH REPORT**

International application No  
PCT/US2011/024952

**A. CLASSIFICATION OF SUBJECT MATTER**  
INV. A61F5/00  
ADD.

According to International Patent Classification (IPC) or to both national classification and IPC

**B. FIELDS SEARCHED**

Minimum documentation searched (classification system followed by classification symbols)  
A61F G01F A61B G01L

Documentation searched other than minimum documentation to the extent that such documents are included in the fields searched

Electronic data base consulted during the international search (name of data base and, where practical, search terms used)  
EPO-Internal

<b>C. DOCUMENTS CONSIDERED TO BE RELEVANT</b>		
Category*	Citation of document, with indication, where appropriate, of the relevant passages	Relevant to claim No.
X	EP 1 704 833 A2 (ETHICON ENDO SURGERY INC [US]) 27 September 2006 (2006-09-27) cited in the application	1-12, 41-47
A	abstract; figures paragraphs [0035] - [0049]	13-40
A	US 2009/270904 A1 (BIRK JANEL A [US] ET AL) 29 October 2009 (2009-10-29) cited in the application	1-47
	abstract; figures paragraphs [0028] - [0038], [0045] - [0048]	
A	EP 1 967 168 A2 (ETHICON ENDO SURGERY INC [US]) 10 September 2008 (2008-09-10) cited in the application	1-47
	abstract; figures paragraphs [0038] - [0052]	
	-/--	

Further documents are listed in the continuation of Box C.

See patent family annex.

\* Special categories of cited documents :

- "A" document defining the general state of the art which is not considered to be of particular relevance
- "E" earlier document but published on or after the international filing date
- "L" document which may throw doubts on priority claim(s) or which is cited to establish the publication date of another citation or other special reason (as specified)
- "O" document referring to an oral disclosure, use, exhibition or other means
- "P" document published prior to the international filing date but later than the priority date claimed

- "T" later document published after the international filing date or priority date and not in conflict with the application but cited to understand the principle or theory underlying the invention
- "X" document of particular relevance; the claimed invention cannot be considered novel or cannot be considered to involve an inventive step when the document is taken alone
- "Y" document of particular relevance; the claimed invention cannot be considered to involve an inventive step when the document is combined with one or more other such documents, such combination being obvious to a person skilled in the art.
- "&" document member of the same patent family

Date of the actual completion of the international search  9 May 2011	Date of mailing of the international search report  24/05/2011
---	--

Name and mailing address of the ISA/ European Patent Office, P.B. 5818 Patentlaan 2 NL - 2280 HV Rijswijk Tel. (+31-70) 340-2040, Fax: (+31-70) 340-3016	Authorized officer  Lager, Johan
--	--

## INTERNATIONAL SEARCH REPORT

International application No  
PCT/US2011/024952

C(Continuation). DOCUMENTS CONSIDERED TO BE RELEVANT		
Category*	Citation of document, with indication, where appropriate, of the relevant passages	Relevant to claim No.
A	US 2007/156013 A1 (BIRK JANEL [US]) 5 July 2007 (2007-07-05) cited in the application abstract; figures paragraphs [0031], [0032], [0035] -----	1-47
A	US 6 221 024 B1 (MIESEL KEITH A [US]) 24 April 2001 (2001-04-24) cited in the application abstract; figures column 5, lines 11-54 -----	1-47
A	US 2005/250979 A1 (COE FREDERICK L [US]) 10 November 2005 (2005-11-10) abstract; figure 3 paragraphs [0029] - [0037] -----	1-47

# INTERNATIONAL SEARCH REPORT

Information on patent family members

International application No PCT/US2011/024952
---

Patent document cited in search report	Publication date	Patent family member(s)	Publication date
EP 1704833	A2	27-09-2006	AT 504259 T 15-04-2011
		AU 2006200583 A1	07-09-2006
		BR PI0600550 A	17-10-2006
		CA 2537562 A1	24-08-2006
		CN 1839765 A	04-10-2006
		EP 2305174 A1	06-04-2011
		JP 2006231061 A	07-09-2006
		KR 20060094492 A	29-08-2006
		SG 125209 A1	29-09-2006
		US 2006189888 A1	24-08-2006
		US 2006199997 A1	07-09-2006
US 2009270904	A1	29-10-2009	AU 2009240634 A1 29-10-2009
			CA 2722516 A1 29-10-2009
			EP 2303200 A1 06-04-2011
			KR 20110014158 A 10-02-2011
			WO 2009132127 A1 29-10-2009
EP 1967168	A2	10-09-2008	CN 101259050 A 10-09-2008
			JP 2008279245 A 20-11-2008
			US 2008221598 A1 11-09-2008
US 2007156013	A1	05-07-2007	AU 2007260917 A1 27-12-2007
			CA 2657994 A1 27-12-2007
			CN 101505690 A 12-08-2009
			EP 2032094 A1 11-03-2009
			JP 2009540964 T 26-11-2009
			KR 20090028632 A 18-03-2009
			WO 2007149992 A1 27-12-2007
US 6221024	B1	24-04-2001	NONE
US 2005250979	A1	10-11-2005	US 2009182356 A1 16-07-2009

# INTERNATIONAL SEARCH REPORT

International application No.  
PCT/US2011/024952

## Box No. II Observations where certain claims were found unsearchable (Continuation of item 2 of first sheet)

This international search report has not been established in respect of certain claims under Article 17(2)(a) for the following reasons:

1.  Claims Nos.: **48-51**  
because they relate to subject matter not required to be searched by this Authority, namely:  
**Rule 39.1(iv) PCT - Method for treatment of the human or animal body by surgery.**
2.  Claims Nos.:  
because they relate to parts of the international application that do not comply with the prescribed requirements to such an extent that no meaningful international search can be carried out, specifically:
3.  Claims Nos.:  
because they are dependent claims and are not drafted in accordance with the second and third sentences of Rule 6.4(a).

## Box No. III Observations where unity of invention is lacking (Continuation of item 3 of first sheet)

This International Searching Authority found multiple inventions in this international application, as follows:

1.  As all required additional search fees were timely paid by the applicant, this international search report covers all searchable claims.
2.  As all searchable claims could be searched without effort justifying an additional fees, this Authority did not invite payment of additional fees.
3.  As only some of the required additional search fees were timely paid by the applicant, this international search report covers only those claims for which fees were paid, specifically claims Nos.:
4.  No required additional search fees were timely paid by the applicant. Consequently, this international search report is restricted to the invention first mentioned in the claims; it is covered by claims Nos.:

### Remark on Protest

- The additional search fees were accompanied by the applicant's protest and, where applicable, the payment of a protest fee.
- The additional search fees were accompanied by the applicant's protest but the applicable protest fee was not paid within the time limit specified in the invitation.
- No protest accompanied the payment of additional search fees.