



US00RE49881E

(19) **United States**
(12) **Reissued Patent**
Buckberry

(10) **Patent Number:** **US RE49,881 E**
(45) **Date of Reissued Patent:** **Mar. 26, 2024**

- (54) **RE-USE OF A HEMODIALYSIS CARTRIDGE**
- (71) Applicant: **Quanta Dialysis Technologies Limited**,
Warwickshire (GB)
- (72) Inventor: **Clive Henry Buckberry**, Warwickshire
(GB)
- (73) Assignee: **QUANTA FLUID SOLUTIONS LTD.**,
Warwickshire (GB)
- (21) Appl. No.: **17/345,665**
- (22) Filed: **Jun. 11, 2021**

(58) **Field of Classification Search**
CPC A61M 1/168; A61M 1/16; A61M 1/1645;
A61M 1/34; A61M 1/3413; A61M 1/342;
(Continued)

- (56) **References Cited**
- U.S. PATENT DOCUMENTS
- | | | |
|-------------|---------|-----------------|
| 2,696,173 A | 12/1954 | Thormod |
| 3,338,171 A | 8/1967 | Conklin et al. |
| 3,468,261 A | 9/1969 | Schmierer |
| 3,605,566 A | 9/1971 | Vetter |
| 3,606,592 A | 9/1971 | Madurski et al. |
- (Continued)

Related U.S. Patent Documents

- Reissue of:
- (64) Patent No.: **10,314,962**
 - Issued: **Jun. 11, 2019**
 - Appl. No.: **14/779,175**
 - PCT Filed: **Mar. 27, 2014**
 - PCT No.: **PCT/GB2014/050978**
 - § 371 (c)(1),
 - (2) Date: **Sep. 22, 2015**
 - PCT Pub. No.: **WO2014/155120**
 - PCT Pub. Date: **Oct. 2, 2014**

FOREIGN PATENT DOCUMENTS

- | | | |
|----|-------------|---------|
| CA | 81430 | 8/1997 |
| DE | 10024447 A1 | 11/2001 |
- (Continued)

OTHER PUBLICATIONS

Ergo-Express Motorized Dialysis Cart, Aug. 14, 2017, youtube.com [online], [site visited Jan. 9, 2022], Available from internet, URL: <https://www.youtube.com/watch?v=j4rAXthOmbY> (Year: 2017).
(Continued)

Primary Examiner — Norca L. Torres Velazquez
(74) *Attorney, Agent, or Firm* — The Marbury Law Group, PLLC

(30) **Foreign Application Priority Data**

Mar. 28, 2013 (GB) 1305755

- (51) **Int. Cl.**
A61M 1/16 (2006.01)
A61M 1/34 (2006.01)
A61M 1/36 (2006.01)
- (52) **U.S. Cl.**
CPC **A61M 1/168** (2013.01); **A61M 1/16**
(2013.01); **A61M 1/1645** (2014.02); **A61M**
1/34 (2013.01);

(Continued)

(57) **ABSTRACT**

The present invention provides a hemodialysis machine comprising a removably mountable cartridge having at least one inlet and at least one outlet, the cartridge defining a fluid pathway between said at least one inlet and said at least one outlet, a sanitisation device having an inlet and an outlet, a conduit connected between an outlet of the cartridge and the inlet of the sanitisation device and, a conduit connected between the outlet of the sanitisation device and an inlet of the cartridge.

36 Claims, 6 Drawing Sheets

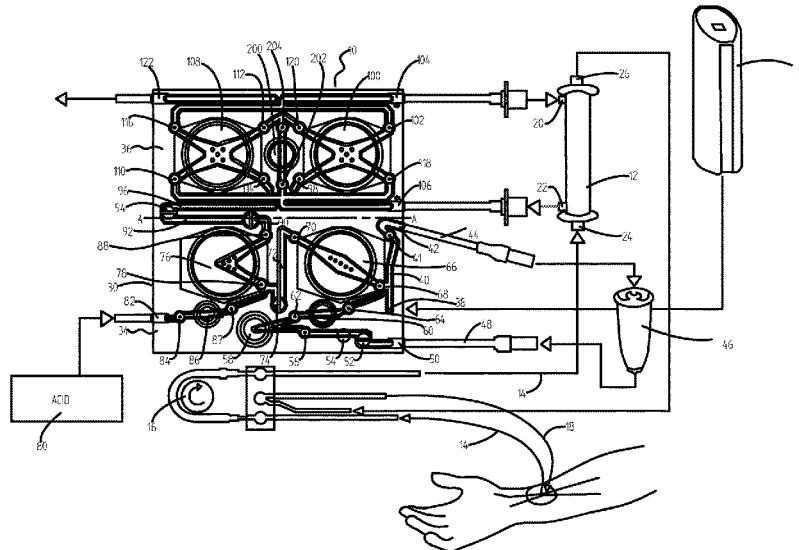

- (52) **U.S. Cl.**
 CPC *A61M 1/3413* (2013.01); *A61M 1/342*
 (2013.01); *A61M 1/3635* (2014.02); *A61M*
2202/0413 (2013.01); *A61M 2205/128*
 (2013.01); *A61M 2205/33* (2013.01)

- (58) **Field of Classification Search**
 CPC *A61M 1/3635*; *A61M 2202/0413*; *A61M*
2205/128; *A61M 2205/33*
 See application file for complete search history.

(56) **References Cited**

U.S. PATENT DOCUMENTS

3,753,493	A	8/1973	Mellor	
3,774,762	A	11/1973	Lichtenstein	
3,807,906	A	4/1974	Breit	
3,921,622	A	11/1975	Cole	
3,972,320	A	8/1976	Kalman	
4,070,725	A	1/1978	Cornelius	
4,142,845	A	3/1979	Lepp et al.	
4,161,264	A	7/1979	Malmgren	
4,205,686	A	6/1980	Harris et al.	
4,353,990	A	10/1982	Manske et al.	
4,366,061	A	12/1982	Papanek et al.	
4,368,261	A	1/1983	Klose et al.	
4,370,983	A	2/1983	Lichtenstein	
4,430,048	A	2/1984	Fritsch	
4,494,912	A	1/1985	Pauullukonis	
D277,991	S	3/1985	Becker	
4,534,755	A	8/1985	Calvert et al.	
4,534,756	A	8/1985	Nelson	
4,546,669	A	10/1985	Fischer et al.	
4,564,342	A	1/1986	Weber et al.	
4,599,165	A	7/1986	Chevallet	
4,648,869	A	3/1987	Bobo, Jr.	
4,666,598	A *	5/1987	Heath A61M 1/3639 210/321.72	
4,710,163	A	12/1987	Butterfield	
4,771,792	A	9/1988	Seale	
4,828,543	A	5/1989	Weiss et al.	
4,897,184	A	1/1990	Shouldice et al.	
D308,249	S	5/1990	Buckley	
4,969,991	A	11/1990	Valadez	
5,000,664	A	3/1991	Lawless et al.	
5,012,197	A	4/1991	Seiffert et al.	
5,032,265	A	7/1991	Jha et al.	
5,055,198	A	10/1991	Shettigar	
5,095,910	A	3/1992	Powers	
5,103,211	A	4/1992	Daoud et al.	
5,126,831	A	6/1992	Nakagawara	
5,232,434	A	8/1993	Inagaki et al.	
5,252,213	A	10/1993	Ahmad et al.	
D341,890	S	11/1993	Sievert et al.	
D344,339	S	2/1994	Yoshikawa et al.	
5,304,349	A	4/1994	Polaschegg	
D347,896	S	6/1994	Dickinson et al.	
D351,470	S	10/1994	Scherer et al.	
5,385,540	A	1/1995	Abbott et al.	
5,421,823	A	6/1995	Kamen et al.	
5,458,468	A	10/1995	Ye et al.	
5,476,368	A	12/1995	Rabenau et al.	
5,476,792	A	12/1995	Ezrielev et al.	
D370,979	S	6/1996	Pascale et al.	
5,558,347	A	9/1996	Nicholson	
5,586,872	A	12/1996	Skobelev et al.	
5,586,873	A	12/1996	Novak et al.	
5,591,344	A *	1/1997	Kenley A61L 2/04 210/636	
5,643,201	A	7/1997	Peabody et al.	
5,650,071	A *	7/1997	Brugger A61M 1/3643 210/646	
5,653,456	A	8/1997	Mough	
5,658,456	A	8/1997	Kenley et al.	
5,665,307	A	9/1997	Kirschner et al.	
5,727,550	A	3/1998	Montecalvo	
D395,085	S	6/1998	Kenley et al.	

5,788,851	A	8/1998	Kenley et al.	
5,807,322	A	9/1998	Lindsey et al.	
5,882,300	A	3/1999	Malinouskas et al.	
5,948,247	A	9/1999	Gillerfalk et al.	
5,957,670	A	9/1999	Duncan et al.	
5,995,910	A	11/1999	Discenzo	
6,077,443	A	6/2000	Goldau	
6,126,831	A	10/2000	Goldau et al.	
6,132,378	A	10/2000	Marino	
6,143,181	A	11/2000	Falkvall et al.	
6,153,102	A	11/2000	Kenley et al.	
6,216,029	B1	4/2001	Paltieli	
6,218,329	B1	4/2001	Singh et al.	
6,251,279	B1	6/2001	Peterson et al.	
6,261,065	B1	7/2001	Nayak et al.	
6,303,036	B1	10/2001	Collins et al.	
6,382,923	B1	5/2002	Gray	
6,514,462	B1	2/2003	Simons	
6,558,347	B1	5/2003	Jhuboo et al.	
6,582,206	B2	6/2003	Schluecker	
6,626,832	B1	9/2003	Paltieli et al.	
6,626,878	B1	9/2003	Leisner et al.	
6,645,176	B1	11/2003	Christenson et al.	
6,663,829	B1	12/2003	Kjellstrand	
6,733,476	B2	5/2004	Christenson et al.	
6,743,204	B2	6/2004	Christenson et al.	
6,801,646	B1	10/2004	Pena et al.	
6,814,547	B2	11/2004	Childers et al.	
6,967,002	B1	11/2005	Edgson et al.	
7,040,142	B2	5/2006	Burbank	
7,107,837	B2	9/2006	Lauman et al.	
7,153,286	B2	12/2006	Busby et al.	
7,284,964	B2	10/2007	McDowell et al.	
7,434,312	B2	10/2008	Christenson et al.	
7,494,590	B2	2/2009	Felding et al.	
7,648,627	B2	1/2010	Beden et al.	
7,857,976	B2	12/2010	Bissler et al.	
7,874,999	B2	1/2011	Busby	
7,896,197	B2	3/2011	Furey et al.	
D641,882	S	7/2011	Hickey et al.	
8,114,043	B2	2/2012	Muller	
8,132,388	B2	3/2012	Nagy et al.	
8,137,184	B2	3/2012	Ajiro et al.	
8,137,300	B2	3/2012	Han et al.	
8,167,431	B2	5/2012	DeCusatis et al.	
8,187,184	B2	5/2012	Muller et al.	
8,192,388	B2	6/2012	Hogard	
8,197,431	B2	6/2012	Bennison	
8,221,320	B2	7/2012	Bouton	
8,348,850	B2	1/2013	Frinak et al.	
8,360,977	B2	1/2013	Marttila et al.	
8,529,490	B2	9/2013	Wariar et al.	
8,535,522	B2	9/2013	Fulkerson et al.	
8,535,525	B2	9/2013	Heyes et al.	
D693,469	S	11/2013	Chung et al.	
8,597,505	B2	12/2013	Fulkerson et al.	
D702,842	S	4/2014	Hyde et al.	
8,685,244	B2	4/2014	Heyes et al.	
8,696,571	B2	4/2014	Marttila et al.	
8,708,908	B2	4/2014	Bouton	
8,708,946	B2	4/2014	Han et al.	
D705,432	S	5/2014	Lura et al.	
8,798,908	B2	8/2014	Bourdeaut	
8,801,646	B2	8/2014	Han et al.	
D714,454	S	9/2014	Amemiya et al.	
D714,946	S	10/2014	Lura et al.	
8,926,544	B2	1/2015	Hogard et al.	
D724,740	S	3/2015	Collins et al.	
8,974,394	B2	3/2015	Frinak et al.	
9,011,334	B2	4/2015	Bouton	
D735,868	S	8/2015	Mareguddi et al.	
9,220,825	B2	12/2015	Buckberry	
D781,410	S	3/2017	Ritter et al.	
9,744,285	B2	8/2017	Heyes et al.	
9,833,553	B2	12/2017	Higgitt et al.	
10,456,516	B2	10/2019	Heyes et al.	
D867,597	S	11/2019	Bauer et al.	
10,543,305	B2	1/2020	Buckberry et al.	
D879,967	S	3/2020	Verguldi et al.	

(56)

References Cited

U.S. PATENT DOCUMENTS

D907,211 S 1/2021 Spurling
 10,881,775 B2 1/2021 Wallace
 10,960,120 B2 3/2021 Wallace et al.
 D924,410 S 7/2021 Mendoza et al.
 D938,046 S 12/2021 Gupta et al.
 2003/0217962 A1 11/2003 Childers et al.
 2004/0195157 A1 10/2004 Mullins et al.
 2004/0206703 A1 10/2004 Bosetto et al.
 2004/0215129 A1 10/2004 Edgson et al.
 2004/0223857 A1 11/2004 Kline
 2005/0020961 A1 1/2005 Burbank et al.
 2005/0205476 A1 9/2005 Chevallet et al.
 2005/0209547 A1 9/2005 Burbank et al.
 2005/0234384 A1 10/2005 Westberg
 2006/0121623 A1 6/2006 He et al.
 2007/0083193 A1 4/2007 Werneth et al.
 2008/0200865 A1 8/2008 Bedingfield
 2008/0283096 A1 11/2008 Scheringer et al.
 2009/0007642 A1 1/2009 Busby et al.
 2009/0009290 A1 1/2009 Kneip et al.
 2009/0012450 A1 1/2009 Shah et al.
 2009/0012452 A1 1/2009 Slepicka et al.
 2009/0012457 A1 1/2009 Childers et al.
 2009/0101550 A1 4/2009 Muller et al.
 2009/0211975 A1 8/2009 Brugger et al.
 2009/0230043 A1 9/2009 Heyes et al.
 2010/0043694 A1 2/2010 Patel
 2010/0045471 A1 2/2010 Meyers
 2010/0089807 A1 4/2010 Heyes et al.
 2010/0139254 A1 6/2010 Sebestyen et al.
 2010/0263687 A1 10/2010 Braun et al.
 2011/0009797 A1 1/2011 Kelly et al.
 2011/0034850 A1 2/2011 Jonsson
 2011/0132838 A1 6/2011 Curtis et al.
 2011/0168614 A1 7/2011 Pouchoulin et al.
 2012/0164022 A1 6/2012 Muginstein et al.
 2012/0269907 A1* 10/2012 Coates A61M 1/1668
 366/162.1
 2012/0276549 A1 11/2012 Cunningham et al.
 2012/0292237 A1 11/2012 Heyes et al.
 2012/0308431 A1 12/2012 Kotsos et al.
 2013/0056419 A1 3/2013 Curtis
 2013/0153495 A1 6/2013 Kelly et al.
 2013/0199998 A1 8/2013 Kelly et al.
 2013/0274642 A1 10/2013 Soykan et al.
 2014/0224736 A1 8/2014 Heide
 2014/0251885 A1 9/2014 Heyes
 2014/0299544 A1 10/2014 Wilt et al.
 2015/0027951 A1 1/2015 Wallace et al.
 2015/0076053 A1 3/2015 Higgitt et al.
 2015/0112119 A1 4/2015 Buckberry
 2015/0129481 A1 5/2015 Higgitt et al.
 2015/0238673 A1 8/2015 Gerber et al.
 2015/0258263 A1 9/2015 Hogard
 2015/0352269 A1 12/2015 Gerber et al.
 2015/0359954 A1 12/2015 Gerber et al.
 2016/0045656 A1 2/2016 Buckberry
 2016/0051743 A1 2/2016 Buckberry
 2016/0058933 A1 3/2016 Ballantyne et al.
 2016/0077644 A1 3/2016 Ritter et al.
 2017/0056576 A1 3/2017 Doyle et al.
 2017/0167983 A1 6/2017 Klomp et al.
 2017/0252498 A1 9/2017 Heyes et al.
 2018/0133391 A1 5/2018 Heyes et al.
 2018/0154059 A1 6/2018 Heyes et al.
 2018/0193545 A1 7/2018 Crnkovich et al.
 2018/0344915 A1 12/2018 Wallace
 2019/0001042 A1 1/2019 Buckberry
 2019/0015577 A1 1/2019 Garrido et al.
 2019/0024654 A1 1/2019 May et al.
 2019/0358381 A1 11/2019 Westenbrink
 2019/0374698 A1 12/2019 Buckberry et al.
 2019/0376504 A1 12/2019 Westenbrink
 2019/0385434 A1 12/2019 Yuds et al.
 2020/0030515 A1 1/2020 Merchant

2020/0075159 A1 3/2020 Bardorz et al.
 2020/0268958 A1 8/2020 Heyes et al.
 2020/0276372 A1 9/2020 Milad et al.
 2020/0330671 A1 10/2020 Buckberry et al.
 2022/0001087 A1 1/2022 Heyes et al.

FOREIGN PATENT DOCUMENTS

EM 004375764-0001 10/2017
 EM 004375764-0002 10/2017
 EM 007955125-0002 6/2020
 EP 0165751 A2 12/1985
 EP 0754468 A2 1/1997
 EP 2219703 A1 8/2010
 EP 2955512 A1 12/2015
 FR 2 310 136 3/1976
 GB 9007955125-0001 5/2020
 GB 9007955125-0002 5/2020
 JP H04266740 9/1992
 JP H06261872 9/1994
 JP H07174659 7/1995
 JP 2000/130334 5/2000
 JP D1645323 11/2020
 WO WO 81/01800 7/1981
 WO WO 91/00113 1/1991
 WO WO 91/16542 10/1991
 WO WO 95/06205 3/1995
 WO WO 95/25893 9/1995
 WO WO 96/25214 8/1996
 WO WO 97/10013 3/1997
 WO WO 97/28368 8/1997
 WO WO 99/29356 6/1999
 WO WO 2000/006217 2/2000
 WO WO 00/57935 10/2000
 WO WO 02/066833 8/2002
 WO WO 02/081917 10/2002
 WO WO 2003/101510 12/2003
 WO WO 05/044339 A2 5/2005
 WO WO 2005/080794 9/2005
 WO WO 2006/120415 11/2006
 WO WO 2006/120417 11/2006
 WO WO 2008/100671 8/2008
 WO WO 2008/106191 9/2008
 WO WO 2008/135245 11/2008
 WO WO 2009/006489 1/2009
 WO WO 2009/024333 2/2009
 WO WO 2009/038834 3/2009
 WO WO 2009/061608 5/2009
 WO WO 2009/127624 10/2009
 WO WO 2010/089130 8/2010
 WO WO 2010/146343 12/2010
 WO WO 2011/027118 3/2011
 WO WO 2011/068885 6/2011
 WO WO 2011/105697 9/2011
 WO WO 2011/105698 9/2011
 WO WO 2013/052680 4/2013
 WO WO 2013/057109 4/2013
 WO WO 2013/110906 8/2013
 WO WO 2013/110919 8/2013
 WO WO 2013/114063 8/2013
 WO WO 2013/121162 8/2013
 WO WO 2013/121163 8/2013
 WO WO 2014/072195 5/2014
 WO WO 2014/082855 6/2014
 WO WO 2014/155121 10/2014
 WO WO 2015/007596 1/2015
 WO WO 2015/022537 2/2015
 WO WO 2016/016870 2/2016
 WO WO 2017/137723 8/2017
 WO WO 2018/115816 6/2018

OTHER PUBLICATIONS

He et al., "A Fluorescent Sensor with High Selectivity and Sensitivity for Potassium in Water," *Journal of the American Chemical Society* 2003 125 (6), 1468-1469.
 Home Dialysis Tescon Aqua Tech, Aug. 1, 2020, youtube.com [online], [site visited Jan. 9, 2022], Available from internet, URL:

(56)

References Cited

OTHER PUBLICATIONS

<https://www.youtube.com/watch?v=WLLPZoS_mz4> (Year: 2020).

Kivi, Air Embolism, Healthline, Aug. 20, 2012, p. 1-5.

LHO2028 Portable Hemodialysis Machine, date unknown, aliexpress.com [online], [site visited Jan. 4, 2022], Available from internet:

<https://www.aliexpress.com/item/1005003324875329.html?randl_currency=USD&_randl_shipto=US&src=google&aff_fcid=1003bab3b8db4e93b9ba88522a14cfc1-1641319351626-05232-UneMJZVf&aff_fsk=UneMJZVf&aff_platform=aaf&sk=UneMJZVf&aff_trace_key=

(Year: 2022).

Medical Hemodialysis Machine, date unknown, aliexpress.com [online], [site visited Jan. 4, 2022], Available from internet: <https://www.aliexpress.com/item/1005003445721549.html?_randl_currency=USD&_randl_shipto=US&src=google&aff_fcid=a524f3f9cd9b4976b6b47962f3439d62-1641319166409-02691-UneMJZVf&aff_fsk=UneMJZVf&aff_platform=aaf&sk=UneMJZVf&aff_trace_key=a524f3f9cd9b4976b6b47962f3439d62-1641319166409-02691-UneMJZVf&terminal_id=d0c2cca4b7664d128cb4801a9ef03ff2

> (Year: 2022).

Millenium HX Portable Dialysis Water System, Jul. 2, 2014,

youtube.com [online], [site visited Jan. 10, 2022], Available from internet, URL: <<https://www.youtube.com/watch?v=IGEbPi2CDsw>

> (Year: 2014).

Portable home dialysis device, Nov. 2, 2017, med-technews.com [online], [site visited Jan. 4, 2022], Available from internet: <<https://www.med-technews.com/news/portable-home-dialysis-device-to-launch-next-year/>

> (Year: 2017).

Sep. 29, 2015 International Preliminary Report on Patentability for PCT/GB2014/050978.

* cited by examiner

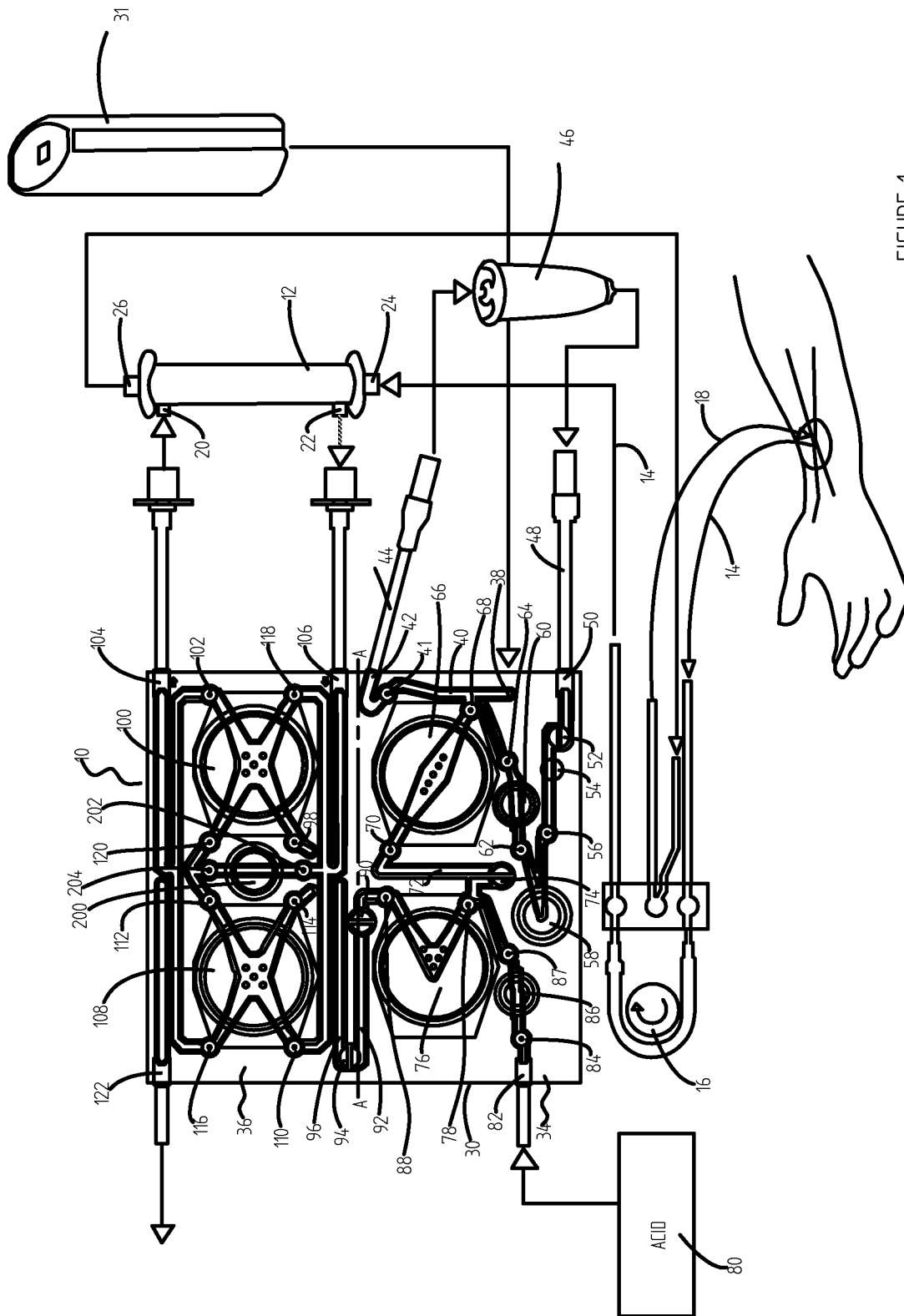

FIGURE 1

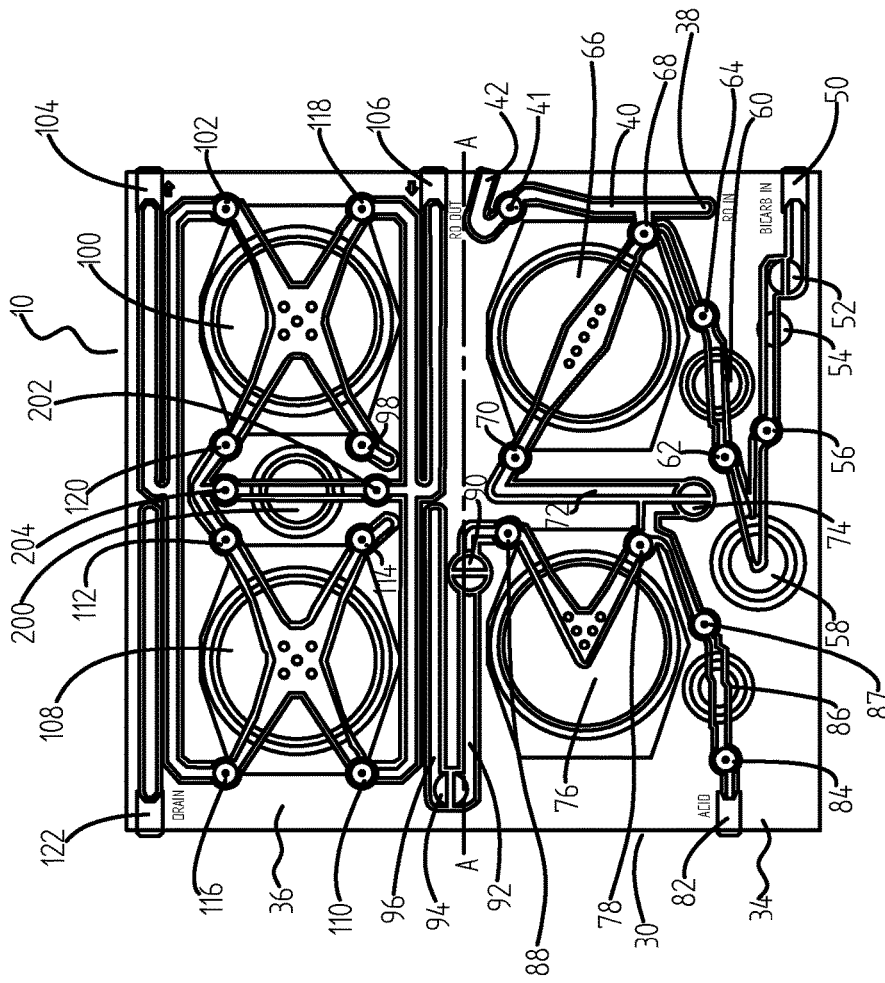

FIGURE 1a

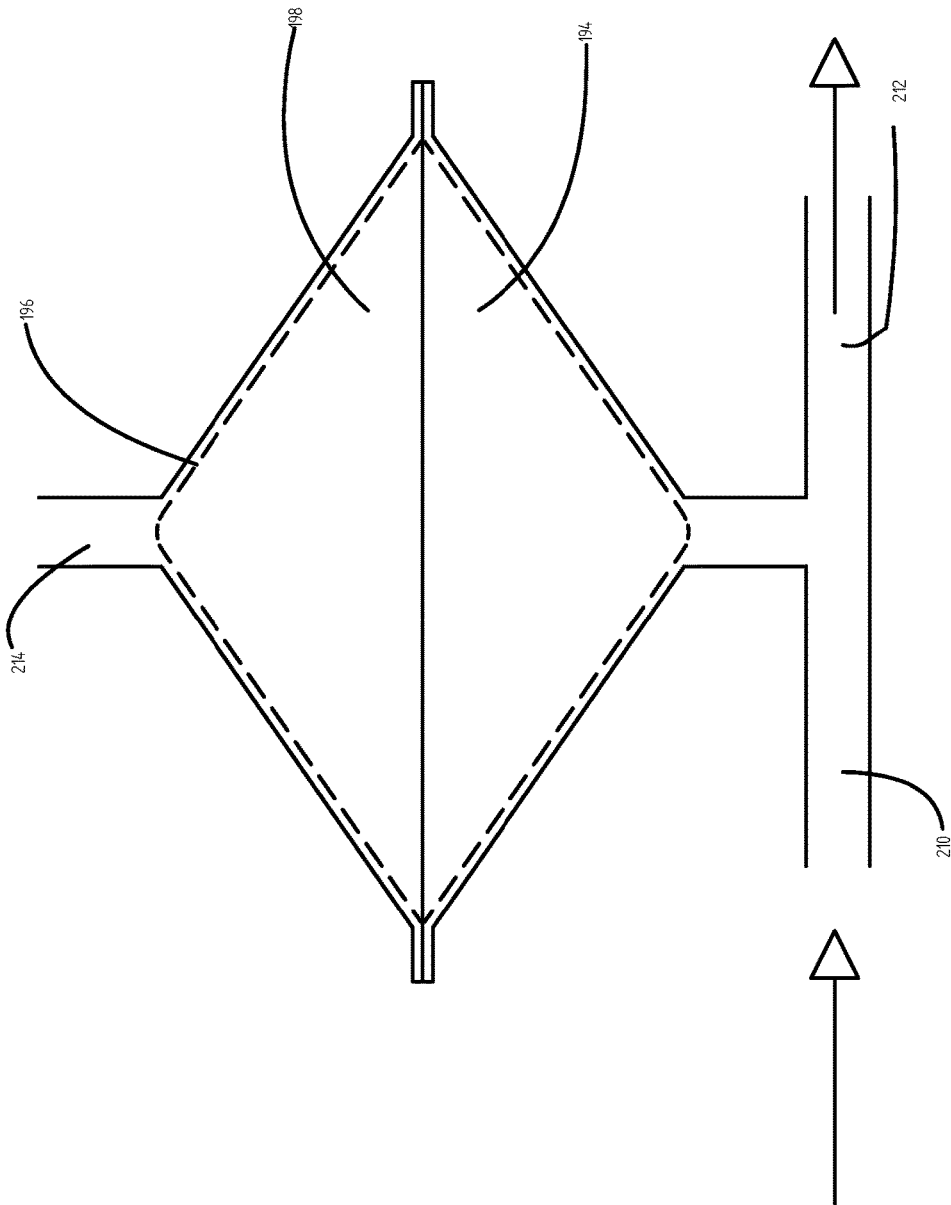

FIGURE 2

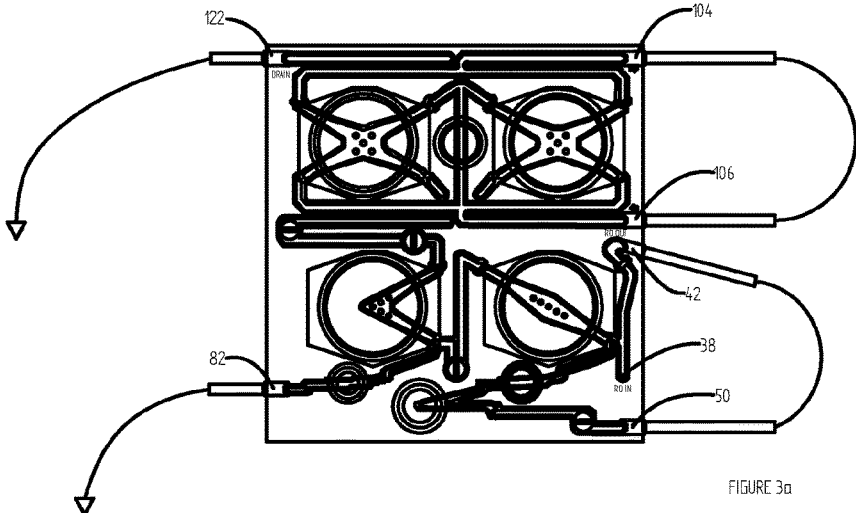

FIGURE 3a

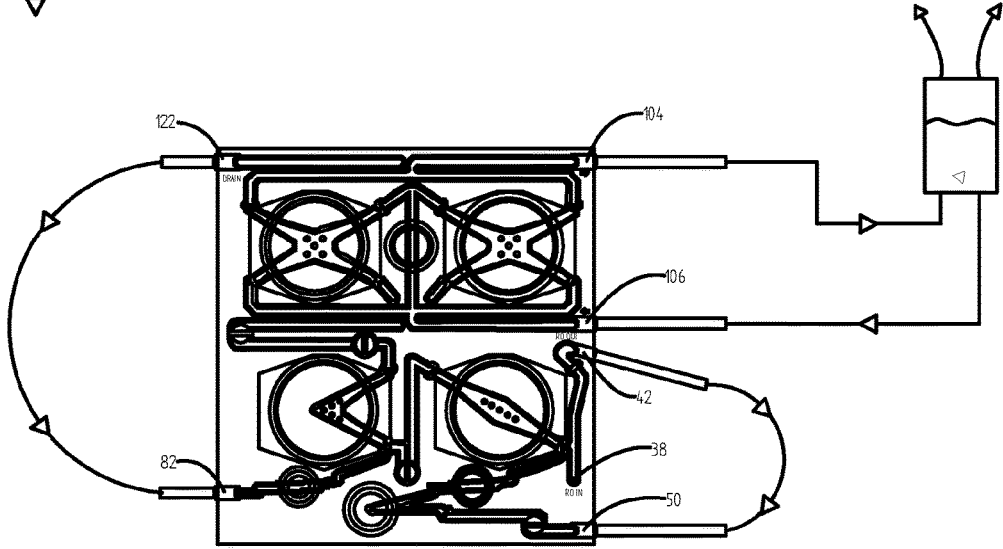

FIGURE 3b

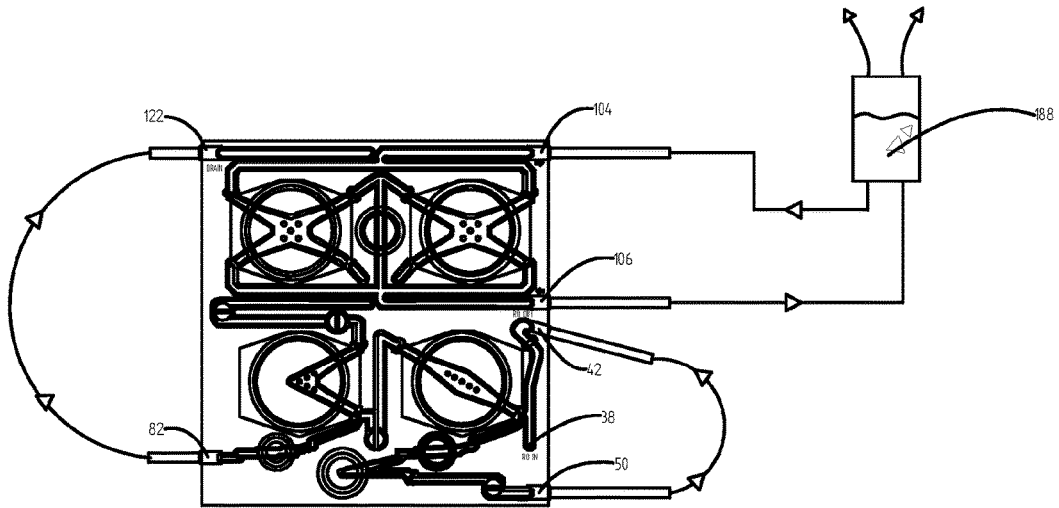

FIGURE 3c

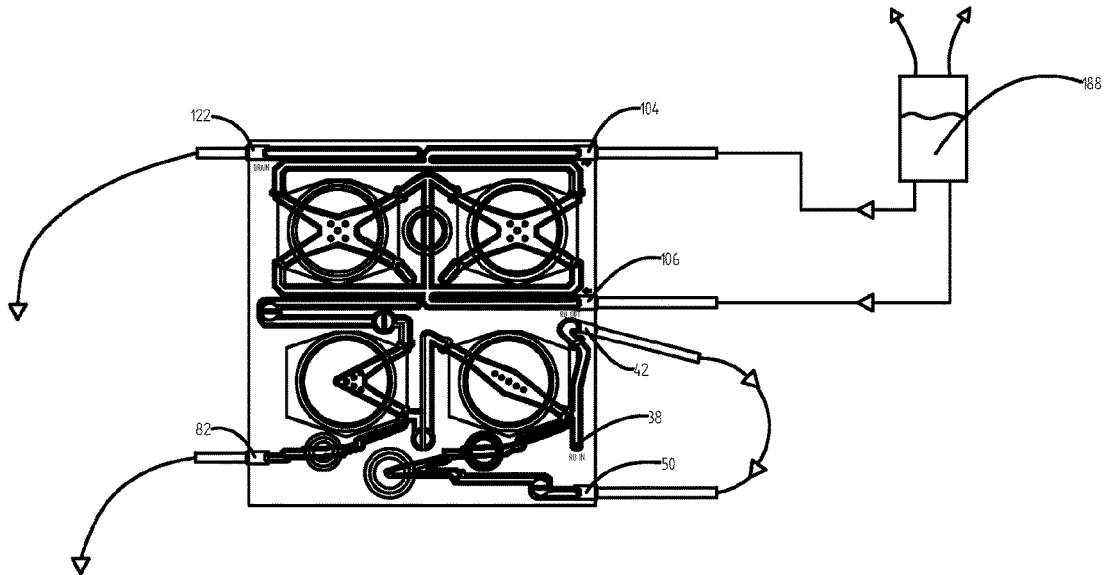

FIGURE 3d

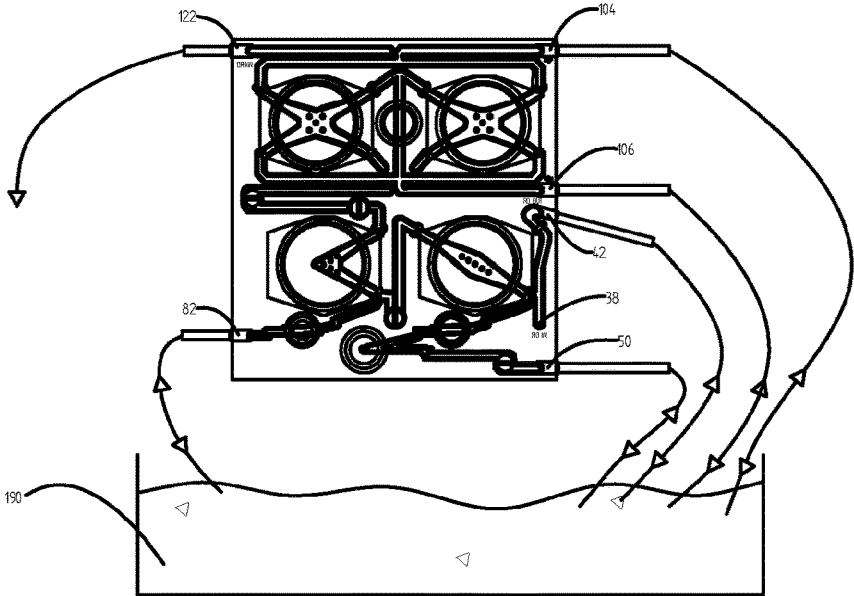

FIGURE 4

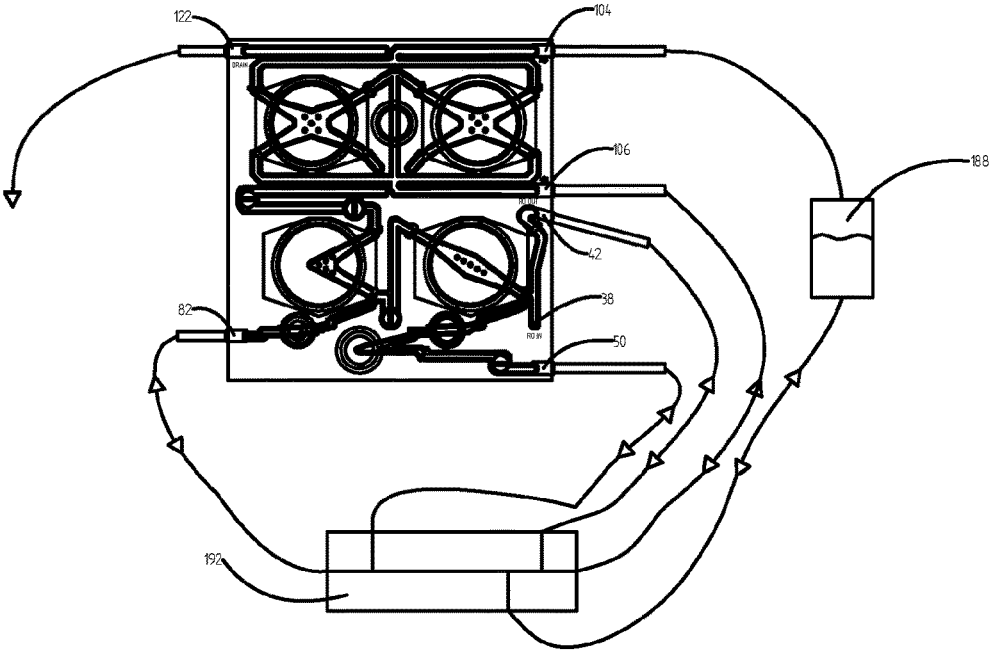

FIGURE 5

RE-USE OF A HEMODIALYSIS CARTRIDGE

Matter enclosed in heavy brackets [] appears in the original patent but forms no part of this reissue specification; matter printed in italics indicates the additions made by reissue; a claim printed with strikethrough indicates that the claim was canceled, disclaimed, or held invalid by a prior post-patent action or proceeding.

The present application is a *reissue patent application of U.S. Pat. No. 10,314,962, which issued 11 Jun. 2019, from U.S. patent application Ser. No. 14/779,175, filed 22 Sep. 2015, which is a 35 USC § 371 submission of international application no. PCT/GB2014/050978, filed on 27 Mar. 2014 and published in the English language on 2 Oct. 2014 with publication no. WO 2014/155120 A1, which claims the benefit of the filing date of application no. GB 1305755.9, filed 28 Mar. 2013.*

The present invention relates to dialysis machines and in particular, but not exclusively to a disposable cartridge for use in hemodialysis machines.

Dialysis is a treatment which replaces the renal function of removing excess fluid and waste products, such as potassium and urea, from blood. The treatment is either employed when renal function has deteriorated to an extent that uremic syndrome becomes a threat to the body's physiology (acute renal failure) or, when a longstanding renal condition impairs the performance of the kidneys (chronic renal failure).

There are two major types of dialysis, namely hemodialysis and peritoneal dialysis.

In peritoneal dialysis treatment, a dialysate solution is run through a tube into the peritoneal cavity. The fluid is left in the cavity for a period of time in order to absorb the waste products, and is subsequently removed through the tube for disposal.

It is common for patients in the early stages of treatment for a longstanding renal condition to be treated by peritoneal dialysis before progressing to hemodialysis at a later stage.

In hemodialysis, the patient's blood is removed from the body by an arterial line and treated by a dialysis machine before being returned to the patient's body by a venous line. The machine passes the blood through a dialyser containing tubes formed from a semi-permeable membrane. On the exterior of the semi-permeable membrane is a dialysate solution. The semi-permeable membrane filters the waste products and excess fluid from the blood into the dialysate solution. The membrane allows the waste and a controlled volume of fluid to permeate into the dialysate solution whilst preventing the loss of larger more desirable molecules, like blood cells and certain proteins and polypeptides.

The action of dialysis across the membrane is achieved primarily by diffusion (the migration of molecules by random motion from a region of higher concentration to a region of lower concentration).

Fluid removal (otherwise known as ultrafiltration) is achieved by altering the hydrostatic pressure of the dialysate solution side of the membrane, causing free water to move across the membrane along the pressure gradient.

The correction of uremic acidosis of the blood is achieved by use of a bicarbonate buffer. The bicarbonate buffer also allows the correction of the blood bicarbonate level.

The dialysate solution consists of a sterilized solution of mineral ions. These ions are contained within an acid buffer

which is mixed with the sterilised water and bicarbonate base prior to delivery to the dialyser.

Hemodialysis machines need to be sanitised between uses and maintained in a sanitised condition. Conventionally, known hemodialysis machines are sanitised either through heat cleaning or chemical cleaning to remove trace elements of dialysate solution from within fluid pathways defined by the hemodialysis machine. Dialysate solution comprises sodium bicarbonate as a constituent part which, if left in the hemodialysis machine, provides a natural food source for biofilm. Growth of biofilm in the fluid pathways defined by the hemodialysis machine can lead to unacceptable bio-incompatibility and errors in the hemodialysis process.

Conventional hemodialysis machines use peristaltic pumps, or similar, to flush a cleaning liquid through the hemodialysis machine in a single direction. Such machines risk contamination and growth of biofilm in areas of the machine where the cleaning liquid cannot access.

The present invention seeks to provide an improved hemodialysis machine.

A first aspect of the invention provides a hemodialysis machine comprising a removably mountable cartridge having a first inlet and a first outlet, the cartridge defining a fluid pathway therebetween, a sanitisation device having an inlet and an outlet, a conduit connected between the first outlet of the cartridge and the inlet of the sanitisation device, and, a conduit connected between the outlet of the sanitisation device and the first inlet of the cartridge.

Advantageously, provision of a sanitisation device permits the cartridge to be sanitised and re-used rather than being disposed of after each dialysis sitting.

Preferably, the cartridge further comprises a first mixing chamber, a second mixing chamber connected to the first mixing chamber, a first flow balance chamber connected to the second mixing chamber, a second flow balance chamber connected to the first flow balance chamber, wherein the sanitisation device is removably connected external to the cartridge between the first mixing chamber and the first flow balance chamber.

In one embodiment the cartridge further comprises a first inlet, a conduit between the first inlet of the cartridge and the first mixing chamber, a second inlet, a conduit between the second inlet of the cartridge and the first mixing chamber, a third inlet, a conduit between the third inlet of the cartridge and the second mixing chamber, a fourth inlet, a conduit between the fourth inlet of the cartridge and the second flow balance chamber, a first outlet, a conduit between the first inlet and the first outlet, a second outlet, a conduit between the first flow balance chamber and the second outlet, a third outlet, and, a conduit between the second flow balance chamber and the third outlet.

In one embodiment the sanitisation device comprises a chemical cleaning receptacle.

Preferably, the cleaning receptacle of one embodiment of the invention contains an acid concentrate.

In one embodiment, the chemical cleaning receptacle comprises a chemical bath.

In another embodiment, the chemical cleaning receptacle comprises a common manifold.

A second aspect of the invention provides a method of cleaning a cartridge for re-use in a hemodialysis machine comprising:

- a) Providing a cartridge having at least one inlet and at least one outlet;
- b) Connecting a sanitisation device between said at least one inlet and said at least one outlet of the cartridge external to the cartridge;

3

- c) Flowing a liquid through the cartridge and the sanitisation device in a first direction;
- d) Flowing the liquid through the cartridge and the sanitisation device in a second direction;
- e) Flushing the liquid out of the cartridge through the at least one outlet.

Advantageously, directing a liquid through the cartridge in first and second directions is more efficient at sanitising the cartridge than directing the liquid through the cartridge in only one direction.

Preferably, the at least one inlet of the cartridge is a spent dialysate inlet and the at least one outlet is a drain port. In one embodiment, the cartridge further comprises a clean dialysate outlet, a water inlet, a water outlet, a bicarbonate inlet and an acid inlet.

In one embodiment, the method further comprises:

- f) Connecting the spent dialysate solution inlet to the clean dialysate solution outlet;
- g) Connecting the water outlet to the bicarbonate inlet;
- h) Disconnecting the drain port;
- i) Connecting the water inlet to a purified water supply;
- j) Flushing purified water through the cartridge and out of the drain port and the acid inlet;
- k) Connecting the drain port to the acid inlet;
- l) Connecting the sanitisation device between the spent dialysate solution inlet and the clean dialysate outlet;
- m) Measuring the conductivity of the liquid in the cartridge when flowing in a first direction to ensure that it indicates acid;
- n) Disconnecting the sanitisation device and re-connecting the spent dialysate solution inlet to the clean dialysate solution outlet;
- o) Flushing purified water through the cartridge and out of the drain port and the acid inlet;
- p) Measuring the conductivity of the liquid in the cartridge to ensure that it indicates purified water;
- q) Disconnecting all cartridge ports; and,
- r) Connecting the cartridge **30** to the hemodialysis machine.

In another embodiment, the method further comprises:

- f) Connecting the spent dialysate solution inlet, clean dialysate solution outlet, bicarbonate inlet, acid inlet and water outlet to a sanitisation device;
- g) Connecting the water inlet to a purified water supply;
- h) Connecting the drain port to a drain;
- i) Flushing purified water through the cartridge and out of the drain port;
- j) Measuring the conductivity of the liquid in the cartridge to ensure that it indicates acid;
- k) Flushing purified water through the cartridge and out of the drain port;
- l) Measuring the conductivity of the liquid in the cartridge to ensure that it indicates purified water;
- m) Disconnecting all cartridge ports; and,
- n) Connecting the cartridge to the hemodialysis machine.

In one embodiment, the method further comprises:

- (f) Connecting a dialyser between the at least one inlet and the at least one outlet
- (g) Connecting the dialyser to a blood pump

Preferably, the at least one outlet is a dialysate solution outlet and the at least one inlet is a dialysate solution inlet.

Advantageously, the cleaning liquid as it flows through the cartridge, in a first direction and in a second direction, also flows through the dialyser and the blood pump to permit re-use of said dialyser and blood pump. The dialyser comprises a semi-permeable membrane which separates a dialysate solution circuit, defined by the cartridge, from a blood circuit, defined by the blood pump. The cleaning

4

liquid permeates through the semi-permeable membrane from the dialysate solution circuit into the blood circuit and is flushed through the cartridge, the dialyser and the blood pump in first and second directions.

In one embodiment, the cartridge comprises at least two inlets and at least two outlets.

In one embodiment, the sanitisation device is connected between one of said at least inlets and one of said at least one outlets and the dialyser is connected between another of said at least one inlets and said at least one outlets.

An embodiment of the invention will now be described, by way of example only, with reference to the following figures.

FIG. 1 shows a schematic of a dialysis system having a disposable cartridge comprising a fluid path defined by pumps and valves.

FIG. 1a shows a detailed schematic view of the cartridge of FIG. 1.

FIG. 2 shows a schematic view of the operation of a pump of the type defined by the disposable cartridge.

FIGS. 3a to 3d show schematic views of a first method of sanitising the disposable cartridge of an embodiment of the invention.

FIG. 4 shows a schematic view of a second method of sanitising the disposable cartridge of an embodiment of the invention.

FIG. 5 shows a schematic view of a third method of sanitising the disposable cartridge of an embodiment of the invention.

Referring to FIGS. 1 and 1a, a dialysis system, generally referred to as **10**, is shown. A dialyser **12** receives blood via an arterial line **14** connected to a patient by a vascular access device (not shown for clarity), for example a hollow needle as typically used for drawing blood from a patient. The blood is pumped from the patient to the dialyser by a peristaltic pump **16**. The blood passes through the dialyser in a known manner and is returned to the patient via a venous line **18**. The dialyser **12** comprises a cylindrical tube closed by opposing ends. A semi-permeable membrane (not shown) is provided within the dialyser tube and separates the patient's blood from a dialysate solution. The membrane extends substantially between the opposing ends of the cylinder. The dialysate solution removes impurities from the patient's blood in a known manner.

The dialyser has an inlet **20** for receiving clean dialysate solution and an outlet **22** for removing spent dialysate solution from the dialyser **12**. The dialyser also has an inlet **24** for receiving untreated blood from the peristaltic pump **16** and an outlet **26** for returning processed blood to the patient. The dialyser **12** is typically provided in a substantially upright orientation, in use, with the patient's blood flowing longitudinally through the dialyser **12** from the blood inlet **24** to the blood outlet **26**. The dialysate solution inlet **20** and dialysate solution outlet **22** are configured to be orientated substantially orthogonal to the blood inlet **24** and blood outlet **26**, and to provide a counter-flow. Dialysate solution is circulated through the hemodialysis machine at a fluid flow rate in the region of 400 ml/min for approximately four hours.

The dialysis system defines a fluid circuit including a cartridge **30** as will now be described. The cartridge **30** is a consumable component in the hemodialysis machine described.

The cartridge **30** is formed from an acrylic plastic such as SG-10 and has a machine side and a patient side. The cartridge **30** defines pump chambers which are closed by respective diaphragms, formed from, for example, DEHP-

5

free PVC, to define respective pumps. In this embodiment, each diaphragm is part of a single, common sheet of material applied to the machine side of the cartridge 30. The individual diaphragms are operable by pneumatic pressure applied thereto.

A series of flow paths are formed in the cartridge 30 for carrying dialysate solution constituted from water, bicarbonate solution and acid solution. The flow paths are located between the sheet of material closing the machine side of the cartridge 30 and a further sheet of the same material closing the patient side of the cartridge 30.

In use, the variation of pressure applied to the flexible diaphragm of each pump chamber is controlled by conventional valving. A pressure source applies either a positive or negative pressure to one side of the diaphragm of each pump chamber, as required, to pump fluid through the fluid paths in the cartridge 30, in a circuit defined by a plurality of valves.

The valves of the cartridge 30 are conventional diaphragm valves defined by respective openings in the cartridge 30 and closed by respective flexible diaphragms. Each valve is operable by applying a negative pressure to the diaphragm to open the valve and applying a positive pressure to the diaphragm to close the valve. The diaphragm of each valve is part of the single, common sheet of material applied to the machine side of the cartridge 30. The valves are opened and closed according to a flow control strategy, as will become apparent.

The machine side of the cartridge 30 abuts a pump driver (not shown) comprising a platen having a plurality of recessed surfaces, each recessed surface substantially corresponding in geometry and volume to a pump chamber defined in the cartridge 30. Each recessed surface has a fluid port connectable with a source of positive fluid pressure and, with a source of negative fluid pressure via a valve.

The positive and negative fluid pressure sources include a pressure pump and a vacuum pump respectively. When the valve is operated to allow fluid to flow into a recessed surface from the source of positive fluid pressure, the diaphragm moves into a corresponding pump chamber and any fluid, i.e. dialysate solution, therein is expelled from that pump chamber via the series of flow paths. When the valve is operated to allow fluid to flow out of a recessed surface to the source of negative fluid pressure, the diaphragm is moved away from a pump chamber and into the corresponding recessed surface to permit fluid to be drawn into that pump chamber via the series of flow paths. The surface of the pump chambers and of the platen provide a positive stop for each diaphragm, to prevent overstretching thereof. The positive stop ensures that the volume of fluid drawn into and pumped from the pump chambers is accurately controlled.

The cartridge 30 has two main functions, preparation of dialysate solution and flow balance. Each function is performed by a separate part of the cartridge as illustrated in FIGS. 1 and 2 by the schematic separation of the cartridge into two parts by the line A-A in the figures. The dialysate preparation function is performed by one part of the cartridge, generally referred to at 34 and the flow balance function is performed by the other part of the cartridge, generally referred to at 36. The cartridge 30 prepares an accurately mixed homogenous dialysate solution and ensures that the flow of clean dialysate supplied to the dialyser 12 matches (to within clinical tolerances) the volume of spent dialysate drawn from the dialyser 12.

The cartridge 30 is provided with a plurality of connections to and from the cartridge 30 as described below.

6

A first inlet port 38, from hereon referred to as the water inlet port, defined in the machine side of the cartridge 30 receives purified water from a purified water supply 31 such as a reverse osmosis water supply.

A first outlet port 42, from hereon referred to as the water outlet port, defined in an edge of the cartridge 30 directs the purified water to a first dialysate solution constituent which, in the illustrated embodiment shown in FIGS. 1 and 1a, is bicarbonate 46.

A second inlet port 50, from hereon referred to as the bicarbonate inlet port, defined in the same edge of the cartridge 30 as the water outlet port 42 receives purified water mixed with the bicarbonate 46.

A third inlet port 82, from hereon referred to as the acid inlet port, defined in the opposite edge of the cartridge 30 to the water outlet port 42 and bicarbonate inlet port 50 receives a second dialysate solution constituent which, in the illustrated embodiment shown in FIGS. 1 and 1a, is acid 80.

A second outlet port 104, from hereon referred to as the clean dialysate solution outlet port, is defined in the same edge of the cartridge as the water outlet port 42 and the bicarbonate inlet port 50. The clean dialysate outlet port 104 directs clean dialysate solution to the dialyser 12.

A fourth inlet port 106, from hereon referred to as the spent dialysate solution inlet port, is defined in the same edge of the cartridge 30 as the water outlet port 42, bicarbonate inlet port 50 and clean dialysate outlet port 104. The spent dialysate solution inlet port 106 receives spent dialysate solution from the dialyser 12.

A third outlet port 122, from hereon referred to as the drain port, is defined in the same edge of the cartridge as the acid inlet port 82. The drain port 122 directs spent dialysate solution out of the cartridge 30.

Dialysate Preparation

Dialysate solution is prepared in the cartridge 30 by combining purified water with two dialysate constituents, namely a bicarbonate solution and an acid solution.

Purified water is admitted into the cartridge 30 from a purified water supply 31 via the water inlet port 38. The purified water passes through a channel 40 via a water inlet valve 41, when open, and exits the cartridge 30 at the water outlet port 42. From here, the purified water is carried by a tube 44 through a bicarbonate cartridge 46 in a known manner to generate a purified water and bicarbonate solution. The purified water and bicarbonate solution is carried by a tube 48 and re-admitted into the cartridge 30 via the bicarbonate inlet port 50.

The temperature of the bicarbonate solution is measured at sensing port 52 and the bicarbonate solution pressure is measured at sensing port 54. The bicarbonate solution passes a bicarbonate control valve 56, when open, before entering a bicarbonate solution reservoir 58 having an inlet and an outlet. The bicarbonate control valve 56 is closed when flow therethrough is not required.

A bicarbonate dosing pump chamber 60 having an inlet and an outlet receives the bicarbonate solution from the bicarbonate solution reservoir 58 through a bicarbonate dosing pump inlet valve 62. The bicarbonate dosing pump chamber 60 is closed by a diaphragm to define a bicarbonate dosing pump which, upon actuation of the diaphragm, pumps the bicarbonate solution from the bicarbonate dosing pump 60 to a first mixing pump chamber 66 (bicarbonate pump chamber). The bicarbonate dosing pump 60 has a bicarbonate dosing pump outlet valve 64 which is closed when the bicarbonate dosing pump inlet valve 62 is open. The bicarbonate dosing pump outlet valve 64 is opened to permit bicarbonate solution to be pumped to the bicarbonate

pump chamber 66. When the bicarbonate dosing pump outlet valve 64 is open, the bicarbonate dosing pump inlet valve 62 is closed to prevent bicarbonate solution from being pumped back into the bicarbonate solution reservoir 58.

The bicarbonate pump chamber 66 having an inlet and an outlet receives the purified water and bicarbonate solution from the bicarbonate dosing pump 60 via a bicarbonate pump inlet valve 68. The bicarbonate pump inlet valve 68, when open, can also admit purified water into the bicarbonate pump chamber 66 from the water inlet port 38. The bicarbonate pump chamber 66 is closed by a diaphragm to define a pump which, upon actuation of the diaphragm, pumps the bicarbonate solution and purified water therein through a bicarbonate pump outlet valve 70 to a second mixing pump chamber 76 (acid pump).

When the bicarbonate pump inlet valve 68 is open, the bicarbonate pump outlet valve 70 and water outlet valve 41 are closed. When the bicarbonate pump outlet valve 70 is open, the bicarbonate pump inlet valve 68 is closed to prevent the bicarbonate and purified water solution from being pumped back into channel 40.

From the bicarbonate pump outlet valve 70, the bicarbonate and purified water solution enters a sensor channel 72 in which the hemodialysis machine measures the conductivity of the bicarbonate and purified water solution in a known manner. The bicarbonate and purified water solution then enters a temperature sensor 74 before, if the conductivity and temperature of the bicarbonate and purified water solution are within tolerance, entering the acid pump chamber 76.

The acid pump chamber 76 having an inlet and an outlet receives the bicarbonate and purified water solution from the bicarbonate pump 66 via an acid pump inlet valve 78. The acid pump inlet valve 78, when open, can also admit an acid solution into the pump chamber 76. The acid pump chamber 76 is closed by a diaphragm to define a pump which, upon actuation of the diaphragm, pumps the acid solution, bicarbonate solution and purified water therein through an acid pump outlet valve 88 to the first flow balance pump chamber 100. When the acid pump inlet valve 78 is open, the acid pump outlet valve 88 is closed. When the acid pump outlet valve 88 is open, the acid pump inlet valve 78 is closed.

The acid solution is admitted into the cartridge 30 from a pre-determined supply of acid 80 via the acid solution inlet port 82. From the acid solution inlet port the acid solution passes through an acid dosing pump chamber 86 via an acid dosing pump inlet valve 84 and an acid dosing pump outlet valve 87. The acid dosing pump outlet valve 87 is closed when the acid dosing pump inlet valve 84 is open. The acid dosing pump inlet valve 84 is closed when the acid dosing pump outlet valve 87 is open.

The dialysate solution exits the acid pump chamber via the acid pump outlet valve 88 and passes through a first dialysate solution temperature sensor 90 and a first dialysate solution conductivity sensor 92. A second dialysate solution temperature sensor 94 and a second dialysate solution conductivity sensor 96 are provided to corroborate the data provided by the first dialysate solution temperature sensor 90 and the first dialysate solution conductivity sensor 92. Providing the data measured by sensors 90, 92, 94 and 96 is within tolerance, the dialysate solution is admitted into a first flow balance pump chamber 100

Flow Balance

The flow balance function of the cartridge 30 provides first and second flow balance pump chambers 100, 108, each having two inlets and two outlets to define two independent

flow paths therethrough. The first and second flow balance pump chambers 100, 108 are of approximately equal volume. Either the first or second flow balance pump chamber 100, 108 pumps dialysate solution to a dialyser 12 and the other of the first or second flow balance pump chambers 100, 108 pumps dialysate solution from the dialyser 12 to the drain port 122. After every approximately 20 strokes of the first and second flow balance pumps 100, 108, their function is reversed.

From this point onwards, dialysate solution will be referred to as either clean dialysate solution or spent dialysate solution. Clean dialysate solution is intended to mean dialysate solution that is either new dialysate solution or clean dialysate solution that has been treated to remove waste product therefrom. Spent dialysate solution is intended to mean dialysate solution that has passed through the dialyser 12 to remove waste fluids from a patient's blood into the dialysate solution.

Each of the first and second flow balance pump chambers 100, 108 are closed by a diaphragm to define respective pumps. The diaphragm is actuated away from a pump chamber by a negative pressure source to draw a volumetrically measured quantity of dialysate solution into the pump chamber. The diaphragm is actuated toward the pump chamber to pump the fluid therein out of an outlet.

The first flow balance pump chamber 100 has a clean dialysate solution inlet valve 98 for receiving clean dialysate solution from the acid pump 76 and a clean dialysate solution outlet valve 102 for pumping clean dialysate solution to the dialyser 12. The first flow balance pump chamber 100 also has a spent dialysate solution inlet valve 118 for receiving spent dialysate from the dialyser 12 and a spent dialysate solution outlet valve 120 for pumping the spent dialysate to drain via drain outlet port 122.

At any one time, only one of valves 98, 102, 118 or 120 will be open and the other three valves will be closed. The flow balance function, as described above, requires alternating the function of each flow balance pump approximately every 20 cycles. Therefore, when the first flow balance pump 100 is pumping clean dialysate solution to the dialyser 12, only valves 98 and 102 are in use and when the first flow balance pump 100 is pumping spent dialysate solution from the dialyser 12 to drain, only valves 118 and 120 will be in use.

The clean dialysate solution is pumped out of the first flow balance pump chamber 100 through the first flow balance pump clean dialysate solution outlet valve 102, upon closure of the first flow balance pump clean dialysate inlet valve 98, to the dialyser 12 via the dialyser outlet port 104.

Spent dialysate solution returns to the cartridge 30 from the dialyser 12 via the dialyser inlet port 106. The second flow balance pump chamber 108 has a spent dialysate solution inlet valve 110 for receiving spent dialysate solution from the dialyser 12 and a spent dialysate solution outlet valve 112 for pumping the spent dialysate solution to drain via drain outlet port 122. The second flow balance pump 108 also has a clean dialysate solution inlet valve 114 for receiving clean dialysate solution from the acid pump chamber 76 and a clean dialysate solution outlet valve 116 for pumping clean dialysate solution to the dialyser 12.

At any one time, only one of valves 110, 112, 114, 116 will be open and the other three valves will be closed. When the second flow balance pump 108 is pumping clean dialysate solution to the dialyser 12, only valves 114 and 116 will be in use and when the second flow balance pump 108 is pumping spent dialysate solution from the dialyser 12 to drain, only valves 114 and 116 will be in use.

In the illustrated example, the operation of the first and second flow balance pumps **100**, **108** can be switched so that the first flow balance pump **100** is used to draw spent dialysate solution from the dialyser **12** and the second flow balance pump **108** is used to pump clean dialysate solution into the dialyser **12** as described below.

The clean dialysate solution is drawn into the second flow balance pump chamber **108** from the acid pump **76** via the second flow balance pump clean dialysate solution inlet valve **114** upon actuation of the diaphragm. The clean dialysate solution is then pumped from the second flow balance pump chamber **108** via the second flow balance pump clean dialysate solution outlet valve **116**, upon closure of the clean dialysate solution inlet valve **114**, to the dialyser **12**.

Spent dialysate solution from the dialyser **12** is drawn into the first flow balance pump **100** via the second flow balance pump spent dialysate solution inlet valve **118**. The spent dialysate solution is then pumped out of the first flow balance pump chamber **100** via the second flow balance pump spent dialysate solution outlet valve **120**, upon closure of the spent dialysate solution inlet valve **118**, to drain via drain outlet port **122**.

The volume of fluid that is returned from the dialyser **12** is greater than the volume of fluid that is pumped to the dialyser via the first or second flow balance pump **100**, **108**. The first and second flow balance pumps have fixed volumes meaning that the excess fluid volume cannot be accommodated in the first or second flow balance pump. An ultrafiltration pump **200** is provided between the first and second flow balance pumps **100**, **108** and has an inlet valve **210** and an outlet valve **212**. The ultrafiltration pump **200** comprises a concave recess in the cartridge closed by a flexible diaphragm, the concave recess and the flexible diaphragm defining an ultrafiltration pump chamber.

In use, the inlet valve **210** of the ultrafiltration pump **200** is opened to allow the ultrafiltration pump to draw in a pre-determined volume of spent dialysate solution. When the inlet valve **210** of the ultrafiltration pump is open, the outlet valve **212** of the ultrafiltration pump **200** is closed. When the ultrafiltration pump **200** has received a volume of spent dialysate solution, the outlet valve **212** is opened and the spent dialysate solution in the ultrafiltration pump chamber is pumped through the outlet valve **212** to drain via the drain outlet port **122**. When the outlet valve **212** of the ultrafiltration pump **200** is open, the inlet valve **210** of the ultrafiltration pump **200** is closed.

FIG. 2 shows a representative view of a flow balance pump **100** according to the present invention. The flow balance pump chamber **194** is provided on the cartridge and is closed by a diaphragm **196** which, at rest, sits across the pump chamber **194**. The pump chamber receives either clean or spent dialysate solution via a dialysate solution inlet port **210** and pumps dialysate solution from the pump chamber via a dialysate solution outlet port **212**.

The cartridge **30** is removably mounted into a hemodialysis machine which has a flow balance pump cavity **198** substantially corresponding in dimension and shape to the pump chamber **194**. Upon supply of positive or negative pressure via a pump cavity pressure inlet port **214**, the diaphragm is actuated into either the pump chamber **194** or pump cavity **198** to either draw fluid into the pump chamber **194** or pump fluid from the pump chamber **194**.

Cartridge Cleaning

After each use, the hemodialysis machine requires sanitising to prevent contamination of a patient's bloodstream during subsequent dialysis sittings. The removable cartridge

30, as described above, is usually disposed of after each sitting. In one embodiment of the invention, the cartridge **30** is sanitised to allow re-use in subsequent dialysis sittings.

A sanitisation device **188**, such as a chemical cleaning receptacle, is connected to the cartridge **30** using the following method (see FIGS. 3a to 3d):

- a) Connecting the spent dialysate solution inlet **104** to the clean dialysate solution outlet **106**;
- b) Connecting the water outlet **42** to the bicarbonate inlet **50**;
- c) Disconnecting the drain port **122**;
- d) Connecting the water inlet **38** to a purified water supply **31**;
- e) Flushing purified water through the cartridge **30** and out of the drain port **122** and out of the acid inlet **82**;
- f) Connecting the drain port **122** to the acid inlet **82**;
- g) Connecting a sanitisation device **188** between the spent dialysate solution inlet **104** and the clean dialysate solution outlet **106**;
- h) Flowing a liquid through the cartridge and the sanitisation device in a first direction;
- i) Flowing the liquid through the cartridge **30** in a second direction;
- j) Disconnecting the sanitisation device **188** and re-connecting the spent dialysate solution inlet **104** to the clean dialysate solution outlet **106**;
- k) Flushing purified water through the cartridge **30** and out of the drain port **122** and the acid inlet **82**;
- l) Disconnecting all cartridge ports **104**, **106**, **42**, **38**, **122**; and,
- m) Re-connecting the cartridge **30** to the hemodialysis machine **10**.

An alternative method of cleaning the cartridge provides (See FIG. 4):

- a) Connecting the spent dialysate solution inlet **104**, clean dialysate solution outlet **106**, bicarbonate inlet **50**, acid inlet **82** and water outlet **42** to a chemical bath **190**;
- b) Connecting the water inlet **38** to a purified water supply **31**;
- c) Connecting the drain port **122** to a drain;
- d) Flushing purified water through the cartridge **30** and out of the drain port **122**;
- e) Flowing a cleaning chemical from the chemical bath **190** through the cartridge **130** in a first direction;
- f) Measuring the conductivity level of the chemical to ensure that it indicates acid;
- g) Flowing the chemical from the chemical bath **190** through the cartridge **30** in a second direction;
- h) Flushing purified water through the cartridge **30** and out of the drain port **122**;
- i) Measuring the conductivity of the purified water to ensure that it indicates purified water;
- j) Disconnecting all cartridge ports **104**, **106**, **50**, **82**, **42**, **38**; and,
- k) Re-connecting the cartridge **30** to the hemodialysis machine **10**.

The chemical bath **190** may be provided with a heater to heat the cleaning chemical contained therein before the cleaning chemical is flowed through the cartridge **30**.

In another alternative method, with reference to FIG. 5, the chemical bath **190** could be replaced by a manifold **192** with a chemical receptacle provided between the manifold and any one or more of the clean dialysate outlet, spent dialysate inlet, bicarbonate port, acid port and water outlet.

In any of the methods of cleaning the cartridge described, the cleaning chemical is drawn through the cartridge by one or more of the acid pump, bicarbonate pump, first flow balance pump or second flow balance pump.

11

The dialyser 12, if connected to the cartridge 30, can also be cleaned by the cleaning liquid to allow re-use for subsequent dialysis sessions. Cleaning fluid, when passing through the dialyser 12, permeates through the semi-permeable membrane of the dialyser 12 and enters a blood pump (not shown) connected to the dialyser 12. In this way, the membrane of the dialyser 12 and the blood pump are cleaned in the same manner as the cartridge 30.

The embodiments of the present invention, described with reference to the figures, are examples only and not exclude variations therefrom from the scope of the claims.

The invention claimed is:

1. A method of cleaning a dialysate mixing and flow balance cartridge for re-use in [the] a hemodialysis machine, comprising:

- a) providing the cartridge, the cartridge having a first mixing pump chamber, a second mixing pump chamber connected to the first mixing pump chamber, a first flow balance pump chamber connected to the second mixing pump chamber, a second flow balance pump chamber, [at least one inlet] a plurality of inlets and [at least one outlet] a plurality of outlets;
 - b) connecting a [sanitisation device] *chemical cleaning receptacle* between the [at least one inlet] plurality of inlets and [the at least one outlet] plurality of outlets of the cartridge, wherein the [sanitisation device comprising a] chemical cleaning receptacle [that] is external to the cartridge;
 - c) flowing a liquid through the cartridge and the [sanitisation device] *chemical cleaning receptacle* in a first direction by actuation of at least one of the pump chambers on the cartridge;
 - d) flowing the liquid through the cartridge and the [sanitisation device] *chemical cleaning receptacle* in a second direction by actuation of at least one of the pump chambers on the cartridge; and
 - e) flowing the liquid out of the cartridge through [the at least one outlet]; and
- wherein the at least one inlet of the cartridge comprises a plurality of inlets, each one of a spent dialysate solution inlet, a water inlet, a bicarbonate inlet and an acid inlet being a respective one of the plurality of inlets; and the at least one outlet comprises a plurality of outlets, each one of a drain port, a clean dialysate solution outlet, and a water outlet being a respective one of the plurality of outlets] *at least one of the plurality of outlets*.

[2. The method of cleaning the cartridge for re-use in the hemodialysis machine according to claim 1, further comprising:

- f) connecting the spent dialysate solution inlet to the clean dialysate solution outlet;
- g) connecting the water outlet to the bicarbonate inlet;
- h) disconnecting the drain port;
- i) connecting the water inlet to a purified water supply;
- j) after performing the steps f through i, flushing purified water through the cartridge and out of the drain port and the acid inlet;
- k) then connecting the drain port to the acid inlet;
- l) then performing the step b connecting step by connecting the sanitisation device between the spent dialysate solution inlet and the clean dialysate solution outlet;
- m) after performing the step l and while performing the step c, measuring conductivity of the liquid in the cartridge when flowing in the first direction to confirm that the liquid in the cartridge is not purified water;
- n) after performing the steps m and d, disconnecting the sanitisation device, re-connecting the spent dialysate

12

solution inlet to the clean dialysate solution outlet, and disconnecting the drain port from the acid inlet;

- o) then performing the step e flowing step by flushing purified water through the cartridge and out of the drain port and the acid inlet;
- p) then measuring the conductivity of the liquid in the cartridge to confirm that the liquid in the cartridge is purified water;
- q) then disconnecting all of the cartridge inlets and outlets; and
- r) then connecting the cartridge to the hemodialysis machine.]

[3. The method of cleaning the cartridge for re-use in the hemodialysis machine according to claim 1, further comprising:

- f) performing the step b connecting step by connecting the spent dialysate solution inlet, the clean dialysate solution outlet, the bicarbonate inlet, the acid inlet and the water outlet to the sanitisation device;
- g) connecting the water inlet to a purified water supply;
- h) connecting the drain port to a drain;
- i) after performing the steps f through h, flushing purified water through the cartridge and out of the drain port;
- j) then performing the step c by flowing a chemical from the sanitization device;
- k) after or while performing step j, measuring conductivity of the liquid in the cartridge to confirm that the liquid in the cartridge is not purified water;
- l) after performing the step k, performing the step e flowing step by flushing purified water through the cartridge and out of the drain port;
- m) then measuring the conductivity of the liquid in the cartridge to confirm that the liquid in the cartridge is purified water;
- n) then disconnecting all of the cartridge inlets and outlets; and
- o) then connecting the cartridge to the hemodialysis machine.]

[4. The method of cleaning the cartridge for re-use in the hemodialysis machine according to claim 1, wherein the spent dialysate solution inlet, the clean dialysate solution outlet, the bicarbonate inlet, the acid inlet and the water outlet are connected to the sanitisation device via a common manifold, the manifold having a single fluid path to the sanitisation device.]

[5. The method of cleaning the cartridge for re-use in the hemodialysis machine according to claim 1, wherein the spent dialysate solution inlet, the clean dialysate solution outlet, the bicarbonate inlet, the acid inlet and the water outlet each have a respective fluid path to the sanitisation device.]

6. The method of claim 1, wherein the plurality of inlets comprises at least one of a spent dialysate solution inlet, a water inlet, a bicarbonate inlet, and an acid inlet, and wherein the plurality of outlets comprises at least one of a drain port, a clean dialysate solution outlet, and a water outlet.

7. The method of claim 1, wherein the plurality of inlets comprises at least two of a spent dialysate solution inlet, a water inlet, a bicarbonate inlet, and an acid inlet.

8. The method of claim 1, wherein the plurality of inlets comprises at least three of a spent dialysate solution inlet, a water inlet, a bicarbonate inlet, and an acid inlet.

9. The method of claim 1, wherein the plurality of inlets comprises a spent dialysate solution inlet, a water inlet, a bicarbonate inlet, and an acid inlet.

13

10. The method of claim 1, wherein the plurality of outlets comprises at least two of a drain port, a clean dialysate solution outlet, and a water outlet.

11. The method of claim 1, wherein the plurality of outlets comprises at least three of a drain port, a clean dialysate solution outlet, and a water outlet.

12. The method of claim 1, wherein the plurality of outlets comprises a drain port, a clean dialysate solution outlet, and a water outlet.

13. The method of cleaning the cartridge for re-use in the hemodialysis machine according to claim 6, further comprising:

- f) connecting the spent dialysate solution inlet to the clean dialysate solution outlet;
- g) connecting the water outlet to the bicarbonate inlet;
- h) disconnecting the drain port;
- i) connecting the water inlet to a purified water supply;
- j) after performing the steps f through i, flushing purified water through the cartridge and out of the drain port and the acid inlet;
- k) then connecting the drain port to the acid inlet;
- l) then performing the step b connecting step by connecting the chemical cleaning receptacle between the spent dialysate solution inlet and the clean dialysate solution outlet;
- m) after performing the step l and while performing the step c, measuring conductivity of the liquid in the cartridge when flowing in the first direction to confirm that the liquid in the cartridge is not purified water;
- n) after performing the steps m and d, disconnecting the chemical cleaning receptacle, re-connecting the spent dialysate solution inlet to the clean dialysate solution outlet, and disconnecting the drain port from the acid inlet;
- o) then performing the step e flowing step by flushing purified water through the cartridge and out of the drain port and the acid inlet;
- p) then measuring the conductivity of the liquid in the cartridge to confirm that the liquid in the cartridge is purified water;
- q) then disconnecting the plurality of inlets and the plurality of outlets from the cartridge; and
- r) then connecting the cartridge to the hemodialysis machine.

14. The method of cleaning the cartridge for re-use in the hemodialysis machine according to claim 6, further comprising:

- f) performing the step b connecting step by connecting the spent dialysate solution inlet, the clean dialysate solution outlet, the bicarbonate inlet, the acid inlet and the water outlet to the chemical cleaning receptacle;
- g) connecting the water inlet to a purified water supply;
- h) connecting the drain port to a drain;
- i) after performing the steps f through h, flushing purified water through the cartridge and out of the drain port;
- j) then performing the step c by flowing a chemical from the chemical cleaning receptacle;
- k) after or while performing step j, measuring conductivity of the liquid in the cartridge to confirm that the liquid in the cartridge is not purified water;
- l) after performing the step k, performing the step e flowing step by flushing purified water through the cartridge and out of the drain port;
- m) then measuring the conductivity of the liquid in the cartridge to confirm that the liquid in the cartridge is purified water;

14

- n) then disconnecting the plurality of inlets and the plurality of outlets from the cartridge; and
- o) then connecting the cartridge to the hemodialysis machine.

15. The method of cleaning the cartridge for re-use in the hemodialysis machine according to claim 6, wherein the spent dialysate solution inlet, the clean dialysate solution outlet, the bicarbonate inlet, the acid inlet and the water outlet are connected to the chemical cleaning receptacle via a common manifold, the manifold having a single fluid path to the chemical cleaning receptacle.

16. The method of cleaning the cartridge for re-use in the hemodialysis machine according to claim 1, wherein the plurality of inlets and the plurality of outlets are connected to the chemical cleaning receptacle via a common manifold.

17. The method of 16, wherein the manifold includes a single fluid path to the chemical cleaning receptacle.

18. The method of cleaning the cartridge for re-use in the hemodialysis machine according to claim 6, wherein the spent dialysate solution inlet, the clean dialysate solution outlet, the bicarbonate inlet, the acid inlet and the water outlet each have a respective fluid path to the chemical cleaning receptacle.

19. The method of cleaning the cartridge for re-use in the hemodialysis machine according to claim 1, wherein each of the plurality of inlets and each of the plurality of outlets have a respective fluid path to the chemical cleaning receptacle.

20. The method of cleaning the cartridge for re-use in the hemodialysis machine according to claim 6, further comprising:

- f) connecting the spent dialysate solution inlet to the clean dialysate solution outlet.

21. The method of cleaning the cartridge for re-use in the hemodialysis machine according to claim 20, further comprising:

- g) connecting the water outlet to the bicarbonate inlet.

22. The method of cleaning the cartridge for re-use in the hemodialysis machine according to claim 21, further comprising:

- h) disconnecting the drain port.

23. The method of cleaning the cartridge for re-use in the hemodialysis machine according to claim 22, further comprising:

- i) connecting the water inlet to a purified water supply.

24. The method of cleaning the cartridge for re-use in the hemodialysis machine according to claim 23, further comprising:

- j) after performing the steps f through i, flushing purified water through the cartridge and out of the drain port and the acid inlet.

25. The method of cleaning the cartridge for re-use in the hemodialysis machine according to claim 24, further comprising:

- k) then connecting the drain port to the acid inlet.

26. The method of cleaning the cartridge for re-use in the hemodialysis machine according to claim 25, further comprising:

- l) then performing the step b connecting step by connecting the chemical cleaning receptacle between the spent dialysate solution inlet and the clean dialysate solution outlet.

27. The method of cleaning the cartridge for re-use in the hemodialysis machine according to claim 26, further comprising:

- m) after performing the step l and while performing the step c, measuring conductivity of the liquid in the

15

- cartridge when flowing in the first direction to confirm that the liquid in the cartridge is not purified water.
28. The method of cleaning the cartridge for re-use in the hemodialysis machine according to claim 27, further comprising:
- n) after performing the steps m and d, disconnecting the chemical cleaning receptacle, re-connecting the spent dialysate solution inlet to the clean dialysate solution outlet, and disconnecting the drain port from the acid inlet.
29. The method of cleaning the cartridge for re-use in the hemodialysis machine according to claim 28, further comprising:
- o) then performing the step e flowing step by flushing purified water through the cartridge and out of the drain port and the acid inlet.
30. The method of cleaning the cartridge for re-use in the hemodialysis machine according to claim 29, further comprising:
- p) then measuring the conductivity of the liquid in the cartridge to confirm that the liquid in the cartridge is purified water.
31. The method of cleaning the cartridge for re-use in the hemodialysis machine according to claim 30, further comprising:
- q) then disconnecting all of the cartridge inlets and outlets.
32. The method of cleaning the cartridge for re-use in the hemodialysis machine according to claim 6, further comprising:
- f) performing the step b connecting step by connecting the spent dialysate solution inlet, the clean dialysate solution outlet, the bicarbonate inlet, the acid inlet and the water outlet to the chemical cleaning receptacle.
33. The method of cleaning the cartridge for re-use in the hemodialysis machine according to claim 32, further comprising:
- g) connecting the water inlet to a purified water supply.

16

34. The method of cleaning the cartridge for re-use in the hemodialysis machine according to claim 33, further comprising:
- h) connecting the drain port to a drain.
- 5 35. The method of cleaning the cartridge for re-use in the hemodialysis machine according to claim 34, further comprising:
- i) after performing the steps f through h, flushing purified water through the cartridge and out of the drain port.
- 10 36. The method of cleaning the cartridge for re-use in the hemodialysis machine according to claim 35, further comprising:
- j) then performing the step c by flowing a chemical from the chemical cleaning receptacle.
- 15 37. The method of cleaning the cartridge for re-use in the hemodialysis machine according to claim 36, further comprising:
- k) after or while performing step j, measuring conductivity of the liquid in the cartridge to confirm that the liquid in the cartridge is not purified water.
- 20 38. The method of cleaning the cartridge for re-use in the hemodialysis machine according to claim 37, further comprising:
- l) after performing the step k, performing the step e flowing step by flushing purified water through the cartridge and out of the drain port.
- 25 39. The method of cleaning the cartridge for re-use in the hemodialysis machine according to claim 38, further comprising:
- m) then measuring the conductivity of the liquid in the cartridge to confirm that the liquid in the cartridge is purified water.
- 30 40. The method of cleaning the cartridge for re-use in the hemodialysis machine according to claim 39, further comprising:
- n) then disconnecting all of the cartridge inlets and outlets.

* * * * *