

19



Europäisches Patentamt
European Patent Office
Office européen des brevets



11 Publication number:

0 288 290 B1

12

EUROPEAN PATENT SPECIFICATION

45 Date of publication of patent specification: **30.12.92** 51 Int. Cl.⁵: **G09F 3/02**

21 Application number: **88303626.1**

22 Date of filing: **21.04.88**

54 **A sign.**

30 Priority: **22.04.87 DK 2040/87**

43 Date of publication of application:
26.10.88 Bulletin 88/43

45 Publication of the grant of the patent:
30.12.92 Bulletin 92/53

84 Designated Contracting States:
AT BE CH DE ES FR GB GR IT LI LU NL SE

56 References cited:
GB-A- 2 025 856 GB-A- 2 042 424
GB-A- 2 134 046 US-A- 670 099
US-A- 749 035 US-A- 1 820 595
US-A- 1 822 390 US-A- 3 535 810

73 Proprietor: **VARIANTSYSTEMET INTERNA-
TIONAL A/S**
Fynsvej 60
DK-5500 Middelfart(DK)

Proprietor: **CONTAINER CENTRALEN A.m.b.A.**
Vestergade 71, 1
DK-5600 Odense(DK)

72 Inventor: **Ingvartsen, Peder**
Kaasvaenget 4, Strib
DK-5500 Middelfart(DK)

Inventor: **Jensen, Bent**
Mollebakken 21, Strib
DK-5500 Middelfart(DK)

Inventor: **Mogensen, Erling**
Faergegaardsvej 78, Strib
DK-5500 Middelfart(DK)

Inventor: **Jensen, Berno Holmgaard**
Drosselvaenget 15, Brylle
DK-5690 Tommerup(DK)

74 Representative: **Brooke-Smith, Fred et al**
Stevens, Hewlett & Perkins 1 Serjeants' Inn
Fleet Street
London EC4Y 1LL(GB)

EP 0 288 290 B1

Note: Within nine months from the publication of the mention of the grant of the European patent, any person may give notice to the European Patent Office of opposition to the European patent granted. Notice of opposition shall be filed in a written reasoned statement. It shall not be deemed to have been filed until the opposition fee has been paid (Art. 99(1) European patent convention).

Description

The invention concerns a plate-shaped sign which is preferably to be used for identification of products, such as transport materiel. The plate is adapted to be placed on an edged object so that it is closed around the edges of the object.

Marking systems in the form of thin metal signs, labels, bosses or the like are known, which are relatively easy to remove or conceal. Consequently, it is not unusual that imitators remove such markings from competitors' products and transfer them to their own products.

It is therefore necessary that such marking systems are shaped so that it is difficult to remove/disassemble them or that they are directly useless after disassembling or when attempting to re-fit them, respectively. In connection with imitation of the sign, it may moreover be advantageous to give it a shape which makes it expensive and difficult to imitate it.

As regards means for prevention of the foregoing, several seal devices having various properties are known e.g. from the GB Patent Applications 2 025 856, 2 134 046 and 2 042 424. The great majority of such means is adapted to act as a type of locking means which are relatively easy to break, and thus it is the visible attempt at getting access to the sealed product which is of importance. These devices frequently comprise a bracket, a wire or the like for locking, the ends of these means being then joined with a seal device adapted for the purpose. Other seal devices are known, where the actual seal member in the locking devices is shaped so that an attempt at removal or subsequent re-fitting leaves visible traces, which is described e.g. in the GB Patent Specification 2 113 616.

A seal for tagging poultry, primarily for use in agriculture, is known from US Patent No. 1,820,595. The seal is placed loosely around an object (a leg) so that it is not harmed by the seal. The material of the seal has been weakened along a bending zone which causes the seal to break in case of backwards bending. Said prior art, however, does not disclose a construction which may be used when a seal is to closely follow the profile of an edged object.

The object of the invention is to provide a method for placing a plate around an edged object. This object is achieved by the method stated in the characterising portion of claim 1.

Another object of the present invention is to provide a plate sign for product marking and of such a type that an attempt at removal or refitting will cause the sign to break along determined rupture lines.

This object is achieved by providing a sign as

stated in the characterising portion of claim 2. Since the plate object is adapted to be applied relatively tightly around an edged object, it will comprise a plurality of bends in the mounted state, one or more of said bends being provided prior to fitting. However, the material at the other bending lines is weakened by means of e.g. punching along the bending line. The perforations thus provided in the material are so dimensioned that the plate can resist a first bending deformation, but will break on backward bending and possible further bending, i.e. removal and refitting, respectively, so that the structure cannot be used again, without it being clearly apparent that such use is illegal.

The dimensioning of these holes or perforations serving as seal means is provided in accordance with the types of materials and plate thicknesses selected in each case, so that both steel and plastics materials may be used. In connection with this, it is to be ensured at the same time that the sign must maintain its break properties at ambient temperatures of about -30°C to 70°C . The perforations mean that the stresses occurring when the sign is bent are transferred to the ribs positioned between the holes. It will therefore be appreciated that these ribs are to have a surface cross section and a thickness which are sufficient to ensure adequate strength for retention of the sign after mounting of it, while the stress established upon mounting of the sign ensures a sufficient strain hardening of the material in the bending zone so that the sign will break with certainty upon additional bending along the bending line. Of course, these break ensuring dimensions may be adapted to the number of weakened bending lines. It will be appreciated that there should be as many pre-provided bends as possible because e.g. just one weakened line will entail that upon removal the sign will receive a relatively greater part of the bending forces because of the rigidity of the other bends and thus take up most of the backward bending, thus making it certain that breaks will occur.

The invention will be explained more fully by the following description of a preferred embodiment with reference to the drawing, in which

fig. 1 shows the plate sign in a punched state, with punched weakened lines and attachment hole,

fig. 2 shows the plate sign in a situation of use, applied around a profile object, and

figs. 3, 4, 5 and 6 show an assembly sequence for the plate sign of the invention.

In fig. 1, the plate sign 1 is shown in a plane, punched state. In the embodiment shown, the plate sign is adapted for bending around a tubular object having a polygonal cross-section, which is rectangular in the illustrated case. Here, the sign is thus

adapted for bending along four bending lines, the ones 2 and 3 shown in broken lines, in the present case, indicating two bends provided prior to fitting. However, the two other bending lines 4 and 5 have their material weakened, which is shown here in the form of punched holes 8 which are oblong and rounded in the longitudinal direction of the bending lines. One end of the sign is provided with a hole 6 to receive a tongue 7 at the opposite end of the sign upon bending.

In this preferred embodiment, two of the bending lines are thus provided with weakenings in their material, which are so dimensioned that the sign will break with certainty upon attempted removal or at any rate attempted re-fitting, one and two bends, respectively, in addition to the assembling deformation, and thus the sign cannot be used again in connection with e.g. thefts. It will be appreciated that said break of the sign will occur with a relatively greater certainty when the sign is provided with as many pre-established bends as possible, so that e.g. the weakened bending area 4 takes up substantially the entire backward bending.

It appears from fig. 2 how the sign is positioned in a situation of use around a rectangular profile pipe, and it will be seen how the plane faces may be used for marking, bossing or the like for product identification.

An assembling sequence for the plate sign of the invention is shown in figs. 3-6. Thus, fig. 3 shows the plate sign in its initial shape according to one embodiment where it has been bent by machine in advance along the lines 2 and 3. The additional bends 4 and 5, on the other hand, are to be made on location by hand and preferably by means of an auxiliary tool adapted for the purpose. As shown by the arrow in fig. 3, the sign is bent along the perforations 4 and assumes the position shown in fig. 4. Then, bending is performed along the line 5, and the tongue 7 is provided with a bend adapted to be received directly in the hole 6. The sign is thus present in the position shown in fig. 5, where the plast bending of the tongue in plane with the adjacent profile side is made, so that the plate sign assumes its final, mounted position of use, as shown in fig. 6.

It will be appreciated that the resistant bending lines of the sign can be provided with various forms of weakenings to facilitate shaping of the sign prior to assembling, and so that a sufficient resistance to backward bending along these lines is maintained.

Claims

1. A method for placing a plate (1), in particular a sign for identification purposes, around an edged object, said plate (1) being closed ar-

ound the edges of the object so that its ends are brought into mechanical interconnection, and said plate (1) being provided with at least one bending line (4, 5) which is made bendable by weakening (8) of the material, characterised in that the plate (1) has been bent along one or more other lines (2, 3) prior to mounting, so that the material along said lines is strain-hardened by the bending, and that the plate is mounted on the edged object by bending of the previously weakened bending line or lines (4, 5), causing the plate (1) to break at said bending lines (4, 5) in case of further bending.

2. A plate (1), in particular for a sign for identification purposes, said plate (1) being adapted to be placed around an edged object, the plate (1) being capable of being bent via weakening (8) along a bending line (4, 5), characterised in that the plate (1) has one or more additional bends (2, 3) which are so strong that the material is strain-hardened by the bending, so that the material is resistant to backward bending about an associated bending line, whereby backwards bending will be absorbed mainly in the weakened bending line or lines (4, 5) which will thus be broken.

Patentansprüche

1. Verfahren zum Anbringen einer Platte, insbesondere eines Schildes für Identifikationszwecke, um einen eckigen Gegenstand herum, wobei die Platte (1) derart um die Kanten des Gegenstands herum geschlossen wird, daß ihre Enden in mechanische Verbindung miteinander gebracht werden, und wobei die Platte (1) mit wenigstens einer Biegelinie (4, 5) versehen ist, die durch eine Schwächung (8) des Materials biegsam gemacht ist, dadurch gekennzeichnet, daß die Platte (1) vor der Anbringung entlang einer oder mehreren anderen Linien (2, 3) gebogen wurde, derart, daß das Material entlang den Linien durch das Biegen streckverfestigt wird, und daß die Platte an dem eckigen Gegenstand durch Biegen der zuvor geschwächten Biegelinie oder -linien (4, 5) angebracht wird, wodurch im Falle eines weiteren Biegens ein Brechen der Platte (1) an den Biegelinien (4, 5) bewirkt wird.
2. Platte (1), insbesondere ein Schild für Identifikationszwecke, wobei die Platte (1) um einen eckigen Gegenstand herum anbringbar ist, und wobei die Platte (1) durch Schwächung (8) entlang einer Biegelinie (4, 5) biegsam ist, dadurch gekennzeichnet, daß die Platte (1) eine

oder mehrere zusätzliche Biegungen (2, 3) aufweist, die so fest sind, daß das Material durch das Biegen streckverfestigt ist, derart, daß das Material einem Rückwärtsbiegen um eine betreffende Biegelinie widersteht, wodurch das Rückwärtsbiegen vornehmlich in der geschwächten Biegelinie oder -linien (4, 5) absorbiert wird, welche daraufhin bricht.

5

Revendications

10

1. Procédé de mise en place d'une plaque (1), en particulier une enseigne à des buts d'identification, autour d'un objet comprenant des bords, ladite plaque (1) étant fermée autour des bords de l'objet, de manière que ses extrémités soient placées en interconnexion mécanique, et ladite plaque (1) étant pourvue d'au moins une ligne de pliage (4, 5) qui peut être pliée grâce à un affaiblissement (8) du matériau, caractérisé en ce que la plaque (1) a été pliée le long d'une ou plusieurs autres lignes (2, 3) avant d'être montés, de manière que le matériau plié suivant lesdites lignes soit écroui au cours du pliage, et en ce que la plaque est montée sur l'objet à bords en pliant la ou les lignes de pliage (4, 5) affaiblies au préalable, ce qui provoque la rupture de la plaque (1) au niveau desdites lignes de pliage dans le cas d'un autre pliage.
2. Plaque (1), destinée en particulier à une enseigne pour des buts d'identification, ladite plaque (1) étant adaptée pour être placée autour d'un objet à bords, la plaque (1) étant capable d'être pliée via un affaiblissement (8), suivant une ligne de pliage (4, 5), caractérisée en ce que la plaque (1) présente une ou plusieurs pliures (2, 3) supplémentaires qui sont suffisamment solides pour que le matériau soit écroui au cours du pliage, de sorte que le matériau résiste à un pliage vers l'arrière effectué au niveau d'une ligne de pliage associée, de manière que le pliage vers l'arrière soit absorbé principalement dans la ou les lignes de pliage affaiblies (4, 5), qui vont ainsi être rompues.

15

20

25

30

35

40

45

50

55

4

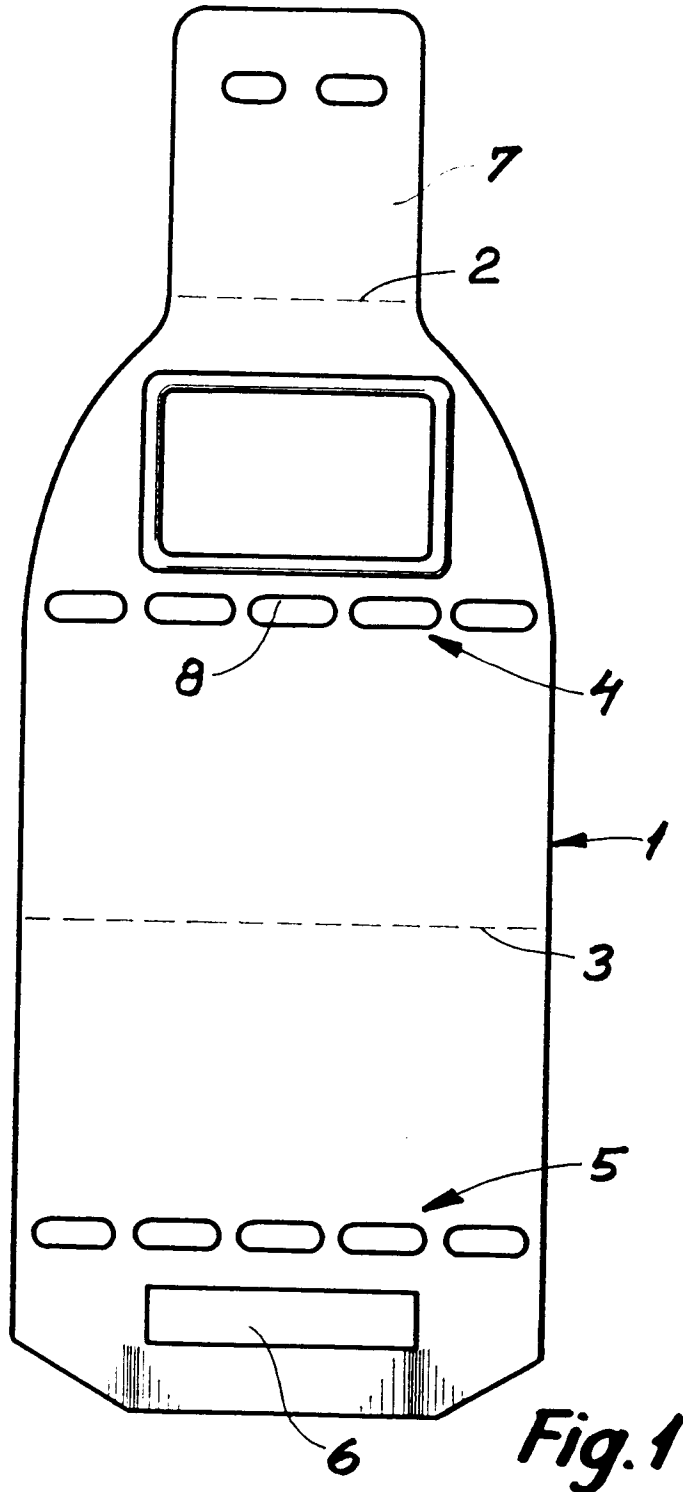

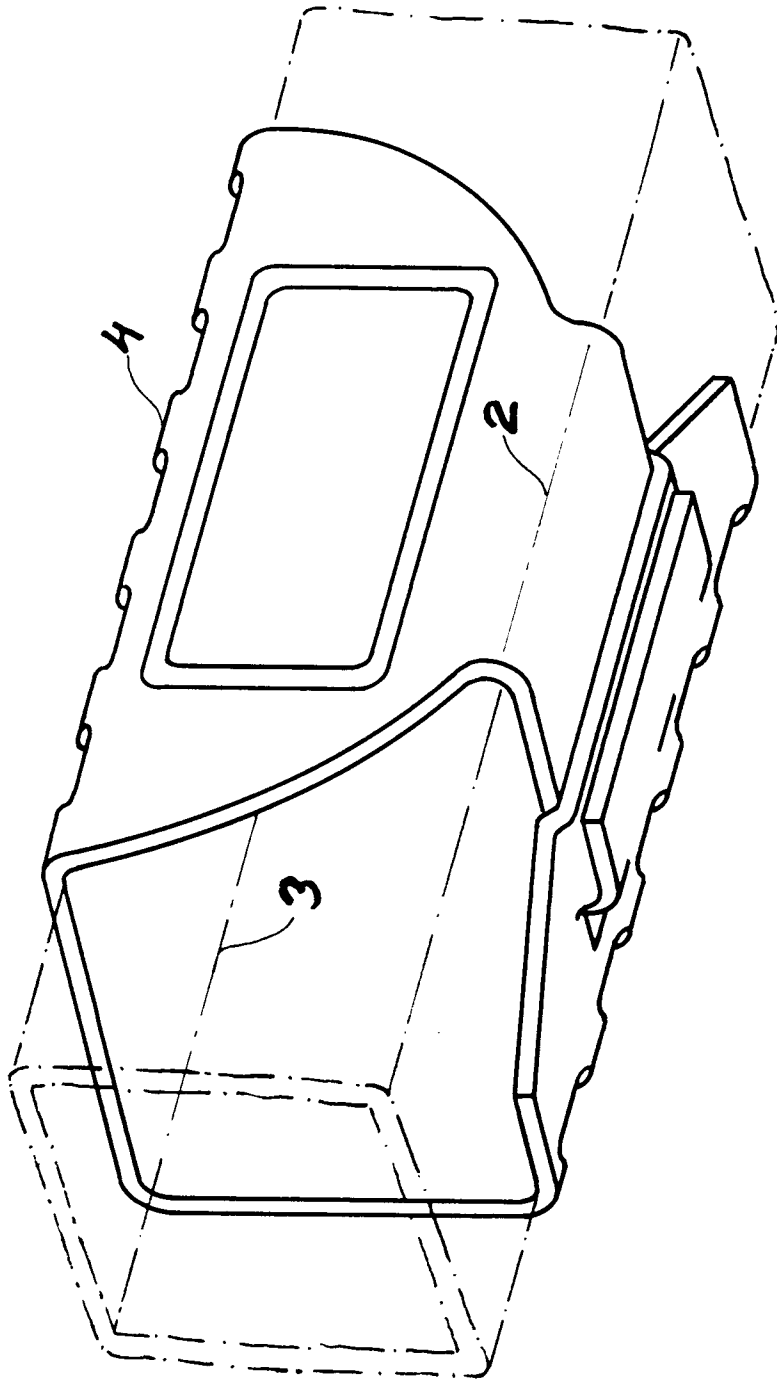

Fig. 2

