

(19)



(11)

EP 4 280 184 B1

(12)

EUROPEAN PATENT SPECIFICATION

(45) Date of publication and mention of the grant of the patent:
30.10.2024 Bulletin 2024/44

(51) International Patent Classification (IPC):
G07F 11/00^(2006.01) G07F 11/04^(2006.01)
G07F 11/10^(2006.01) G07F 11/26^(2006.01)

(21) Application number: **23173604.2**

(52) Cooperative Patent Classification (CPC):
G07F 11/005; G07F 11/04; G07F 11/10;
G07F 11/26

(22) Date of filing: **16.05.2023**

(54) **VENDING MACHINE FOR DISPENSING PACKAGED PRODUCTS AND METHOD FOR DISPENSING A PACKAGED PRODUCT FROM A VENDING MACHINE**

VERKAUFSAUTOMAT ZUR AUSGABE VON VERPACKTEN PRODUKTEN UND VERFAHREN ZUR AUSGABE EINES VERPACKTEN PRODUKTS AUS EINEM VERKAUFSAUTOMATEN

DISTRIBUTEUR AUTOMATIQUE POUR DISTRIBUER DES PRODUITS EMBALLÉS ET PROCÉDÉ POUR DISTRIBUER UN PRODUIT EMBALLÉ À PARTIR D'UN DISTRIBUTEUR AUTOMATIQUE

(84) Designated Contracting States:
AL AT BE BG CH CY CZ DE DK EE ES FI FR GB GR HR HU IE IS IT LI LT LU LV MC ME MK MT NL NO PL PT RO RS SE SI SK SM TR

- **PRAT VILELLA, Joan**
08508 Les Masies de Voltregà (ES)
- **BOVER CAPDEVILA, Eudald**
08500 Vic (ES)

(30) Priority: **16.05.2022 EP 22382468**

(74) Representative: **Torner, Juncosa I Associats, SL**
C / Pau Claris, 108, 1r 1a
08009 Barcelona (ES)

(43) Date of publication of application:
22.11.2023 Bulletin 2023/47

(73) Proprietor: **Awayter, SL**
08500 Vic (ES)

(56) References cited:
WO-A1-97/39431 GB-A- 2 177 075
US-A- 5 285 041

(72) Inventors:
• **SANS SERRA, Jordi**
08503 Gurb (ES)

Note: Within nine months of the publication of the mention of the grant of the European patent in the European Patent Bulletin, any person may give notice to the European Patent Office of opposition to that patent, in accordance with the Implementing Regulations. Notice of opposition shall not be deemed to have been filed until the opposition fee has been paid. (Art. 99(1) European Patent Convention).

EP 4 280 184 B1

Description

Technical field

[0001] The present invention relates to the field of vending machines and, in particular, to the field of vending machines for dispensing packaged products. The present invention also relates to a method for dispensing a packaged product from a vending machine. The present invention is specially envisaged for dispensing packaged food products.

State of the Art

[0002] Vending machines are widely used for dispensing different kinds of items, such as food products, beverages, cigarettes, newspapers, prizes, medicines, books, etc. Typically, the items are dispensed upon payment by cash, credit card or any other suitable form of payment. The present invention is specially envisaged for vending machines for dispensing packaged food products, although it could also be used, with or without modification, for dispensing other packaged products.

[0003] Vending machines commonly store items to be dispensed in vertical or horizontal stacks. The present invention is directed to vending machines storing items to be dispensed in vertical stacks.

[0004] In vending machines storing items in vertical stacks, items to be dispensed are typically lowered by gravity and/or by using more or less complex mechanisms.

[0005] It is crucial that vending machines only dispense the paid and/or selected item, thus control means need to be provided in this respect.

[0006] There are known in the art vending machines that store the items to be dispensed in gravity lowered vertical stacks of items. Said known vending machines comprise relatively complex mechanisms to dispense the lowermost product of said vertical stacks.

[0007] For example, WO 94/28700 A2 discloses a vending machine that includes a refrigeration compartment which holds a plurality of inventory magazines, each inventory magazine holding several stacks of food packages. When a consumer makes a selection from the vending machine, the inventory carousel rotates until an inventory magazine which holds the selected food item is positioned over a food delivery door. Retention levers in that inventory magazine are then actuated, and the bottom food package in each stack is released. For all stacks except the lowermost one, the food package drops to the next lower stack.

[0008] In the vending machine disclosed in WO 94/28700 A2 the food package includes a tray which holds the food item and a package sleeve which encloses the tray. The ends of the package sleeve are bevelled to aid the retention levers in holding the food package.

[0009] In WO 94/28700 A2, an inventory magazine release member has first and second cam surfaces; a first

retention lever rotatably mounted on a side of a product chute, the first retention lever including a third cam surface that contacts the first cam surface, wherein: when the inventory magazine release member is positioned in a first position, contact between the first and third cam surfaces causes the first retention lever to be retracted from the product chute; and when the inventory magazine release member is positioned in a second position, contact between the first and third cam surfaces causes the first retention lever to be extended into the product chute; and a second retention lever rotatably mounted on the side of the product chute below the first retention lever, the second retention lever including a fourth cam surface that contacts the second cam surface, wherein: when the inventory magazine release member is positioned in a first position, contact between the second and fourth cam surfaces causes the second retention lever to be extended into the product chute; and when the inventory magazine release member is positioned in a second position, contact between the second and fourth cam surfaces causes the second retention lever to be retracted from the product chute.

[0010] US 3651752 A discloses a method and apparatus for sequentially heating and dispensing a plurality of individually packaged good products, wherein the products are sequentially moved to, and supported at, a heating dispensing station. While at such station, each product is heated by passing an electrical current there-through and then dispensed by removing the support therefor so that the product gravitates away from the station.

[0011] US 3137410 A discloses a coin-operated vending machine comprising a number of vertical guides arranged side by side within a cabinet. At the lower end of each guide there is a drawer slide, adapted to be released by a known type of coin-operated mechanism. The articles to be vended are placed in pallets made from an easily cleaned hygienic material. A number of filled pallets are stacked vertically in the aforementioned guides or channels, the lowermost pallet of each stack being engaged by a drawer slide. Side flanges of the lowermost pallet nest upon fixed horizontal guides, the leading ends of said horizontal guides terminating in pivoted, spring-loaded catches. Said drawer slide is arranged to move in fixed horizontal slideways which are extended beyond the aforementioned horizontal guides and spring-loaded catches, said extensions of the horizontal slideways being provided with overhanging lips at their upper edges. In the withdrawal movement, the lowermost pallet is carried along the horizontal guides by the drawer slide, depressing the pivoted, spring-loaded catches, and, after passing over the catches, falling onto a horizontal platform affixed to the lower edges of the horizontal slideways. At the fully withdrawn position of the drawer slide, the pallet therefore rests on the horizontal platform between the horizontal slideways, is restrained against horizontal movement by the drawer slide itself and is restrained against vertical withdrawal by overhanging lips

on upper edges of the horizontal slideways. At this point, the contents of the pallet are accessible, and can be removed by the customer.

[0012] US 3000538 A discloses a food vending machine, a tray adapted to have food items disposed thereon, a platform adapted for supporting the tray, a hinge supporting the rear edge of the platform, means for normally supporting the body of the platform in horizontal position, and means operable for releasing the latter means to cause the tray to drop into inclined position and to allow the tray to slide off the platform, the tray having rear and side flanges only rising therefrom to confine the food items and providing a free front edge allowing said items to slide thereover for final discharge, and the side flanges having inwardly turned tongues to serve as supporting means for additional trays.

[0013] GB 2177075 A discloses an apparatus for sequentially releasing flanged containers from a stack of such containers comprising a pair of opposed paddle wheels rotatable about horizontal axes, paddles of the paddle wheels extending horizontally to support a lowermost container in the stack and on rotation thereof releasing the lowermost container and supporting the remainder of the stack, the paddles having radially extending projections and radially extending ribs adapted to support substantially the whole length of the flanges parallel to the axes.

[0014] US 5285041 A discloses an automated food vending system that includes a vending machine having a plurality of stacks and dispenser mechanisms for dispensing standardized food package units, a microwave oven having a code reader located in a predetermined position in an interior cavity of the oven, and the food package units having standardized shapes corresponding to the vending stacks and to the microwave oven cavity. The food packages have a code for controlling the microwave oven printed in a predetermined position which is readable automatically by the code reader when the package unit is inserted in the oven. The dispenser mechanism has a configuration which allows it to be installed in existing vending machines for canned beverages. It may be formed as a pair of pivotable holding members spaced apart in the widthwise direction of the holding stack, or as a pair of continuous belts spaced apart in the depthwise direction of the holding stack. The interior of the oven may be shaped to hold two or more different standardized package shapes and can have a drive element for controllably moving the package past the code reader. The food package is formed with a quadrangular-sided tray portion and a rectangular, laterally projecting lip around the upper edges of the tray portion, and has the code printed extending in a linear direction. Alternatively, the food package unit is formed with a cylindrical shape and has the code printed extending in a circumferential direction.

[0015] WO 97/39431 A1 discloses an automatic distributor of hot food in trays comprising at least one vertical stacker containing a plurality of trays piled on top of one

another, at the base of which an upper support device is arranged, which device is mobile on command between an active position in which it supports the tray at the bottom of the stacker and an inactive position in which it leaves tray free to rest on a plate, arranged horizontally, borne by a lower support device. The plate is mobile and able to perform a sequence of movements: nearing a bottom tray in the pile, a descending movement, parallel to itself, and a rotation movement by effect of which it tilts, and the tray is made to slide onto a rest plane located below the stacker, on which plane a pusher acts to transport the tray internally of a microwave oven for heating the contents of the tray.

15 Disclosure of the invention

[0016] The aforementioned vending machines known in the art comprise complex mechanisms to dispense the vertically stored food products. Said complex mechanisms, can be expensive and difficult to manufacture, and also can require laborious and expensive maintenance.

[0017] Moreover, known vending machines in the art are designed and configured for a certain type of product having certain dimensions, being difficult, or even impossible, to adapt to different types of products that might be needed to be dispensed, particularly in the case wherein the different types of products have different dimensions.

[0018] Therefore, it is an object of the present invention to provide a vending machine for dispensing packaged products that has a simple and easy to manufacture dispensing mechanism, which can also be easily adapted to different configurations or types of packaged products. In order to achieve this, according to a first aspect of the present invention it is disclosed a vending machine for dispensing packaged products having opposed edge holding portions, and according to a second aspect of the present invention a method for dispensing a packaged product from a vending machine is disclosed.

[0019] The vending machine of the present invention has a housing which comprises: a collection zone for a dispensed packaged product; a structure for storing at least one vertical stack of gravity dischargeable packaged products; a dispensing mechanism for supporting a corresponding stack of gravity lowered packaged products and dispensing the lowermost product of said stack, wherein the dispensing mechanism comprises at least two retention units arranged on opposite sides of the vertical stack, each retention unit having a retention position for interfering with an edge holding portion of the lowermost packaged product of the stack and a dispensing position for releasing said holding edge portion of said lowermost packaged product, and wherein the vending machine further comprises a control unit configured to drive the retention units from the retention position to the dispensing position and to return the retention units to the retention position from the dispensing position once

at least said lowermost packaged product of the stack has fallen by gravity.

[0020] In particular, the present invention discloses a vending machine for dispensing packaged products, each one of said packaged products having opposed edge holding portions, said vending machine having a housing which comprises: a collection zone for a dispensed packaged product; a store structure for storing at least one vertical stack of gravity lowered packaged products, each vertical stack of gravity lowered packaged products defining a longitudinal axis; a dispensing mechanism for supporting a corresponding stack of gravity lowered packaged products and dispensing the lowermost packaged product of said stack; the dispensing mechanism comprising at least two retention units arranged on opposite sides of the vertical stack, each retention unit having a retention position for interfering with an edge holding portion of the lowermost packaged product of the stack and a dispensing position for releasing said edge holding portion of said lowermost packaged product; the vending machine further comprising a control unit configured to drive the retention units from the retention position to the dispensing position and to return the retention units to the retention position from the dispensing position once at least said lowermost packaged product of the stack has fallen by gravity; each retention unit comprising a support body, a movable element and a dispense actuator for moving the movable element from a retention position to a dispensing position and vice versa; wherein each movable element is configured to move from the retention position to the dispensing position following a backwards movement along a linear path, and to move from the dispensing position to the retention position following an advance movement along the linear path.

[0021] The longitudinal axis defined by each stack of gravity lowered packaged products is preferably vertical.

[0022] The dispensing mechanism of the vending machine object of the present invention is simple, effective and can be easily adapted to different kinds of packaged products as, in most cases, a simple change in the configuration of the control unit driving said dispensing mechanism will suffice to adapt the dispensing mechanism to a different packaged product or to a different format of the same packaged product. In comparison, in order to adapt the vending machines of the known prior art, extensive mechanical changes are necessary.

[0023] According to the first aspect of the present invention, the linear path may be perpendicular to the longitudinal axis defined by the corresponding stack of gravity lowered packaged products. However, the linear path may also be inclined, i.e. may not be perpendicular, with respect to the longitudinal axis defined by the corresponding stack of gravity lowered packaged products.

[0024] According to the first aspect of the present invention, the support body may comprise a frontal wall for guiding the at least one edge holding portion of the packaged product.

[0025] According to the first aspect of the present invention, the support body may further comprise a sloped wall adjacent to the frontal wall for guiding the at least one edge holding portion of the packaged product.

5 **[0026]** According to the first aspect of the present invention, the frontal wall may comprise at least one opening for the passage of at least part of the movable element.

10 **[0027]** According to the first aspect of the present invention, the frontal wall may comprise two or more openings for the passage of two or more parts of the corresponding movable element.

15 **[0028]** According to the first aspect of the present invention, adjacent openings may be separated by an intermediate region, each intermediate region interfering with the movable element to define its retention position. In particular, each intermediate region may interfere with the advance movement of the movable element to define its retention position.

20 **[0029]** According to the first aspect of the present invention, the movable element may comprise a recess for each intermediate region of the corresponding opening.

25 **[0030]** According to the first aspect of the present invention, each recess may have a distal surface for interfering with the corresponding intermediate region, acting as a stop of the movable element and defining the retention position thereof.

30 **[0031]** According to the first aspect of the present invention, the recess may have two lateral surfaces extending towards the distal surface in a convergent manner, that is to say, the recess may narrow towards the distal surface thereof. Preferably, all recesses are equally shaped, although one movable element can also have recesses differently shaped.

35 **[0032]** According to the first aspect of the present invention, the intermediate regions and corresponding recesses may have different widths. However, all intermediate regions, and thus, all recesses, may also have the same width.

40 **[0033]** According to the first aspect of the present invention, the intermediate region may be part of the frontal wall, that is to say, the intermediate region may be the region of the frontal wall comprised between two consecutive openings.

45 **[0034]** According to the first aspect of the present invention, the movable element may be symmetrical with respect to a transversal axis of symmetry.

[0035] According to the first aspect of the present invention, the movable element may comprise at opposite longitudinal ends thereof a protrusion for guiding the movable element through the corresponding opening. Preferably, said protrusions extend towards a region for receiving the corresponding vertical stack of gravity lowered packaged products.

55 **[0036]** According to the first aspect of the present invention, the vending machine may further comprise a lowering mechanism for receiving the dispensed packaged product and lowering it to a transport element for

conveying the dispensed packaged product to the collection zone. Alternatively, the lowering mechanism may also lower the dispensed packaged product to the collection zone. That is to say, the lowering mechanism may lower the dispensed packaged product to the collection zone or to the transport element.

[0037] According to the first aspect of the present invention, the lowering mechanism may comprise a movable platform configured for being raised to a receiving position, in which it may receive the dispensed packaged product, and for being lowered to a discharging position, in which the dispensed packaged product may be discharged to the transport element or to the collection zone.

[0038] According to the first aspect of the present invention, the lowering mechanism may be movable along a guide.

[0039] According to the first aspect of the present invention, the lowering mechanism may comprise at least one discharging ramp.

[0040] According to the first aspect of the present invention, the movable platform may be configured to tilt. In embodiments comprising at least one discharging ramp and a tilting platform, the movable platform preferably tilts towards the at least one discharging ramp.

[0041] According to the first aspect of the present invention, said support body may comprise a first U-shaped guide member for guiding the movable element, said U-shaped guide member defining the retention and the dispensing position of the movable element.

[0042] According to the first aspect of the present invention, the support body may comprise a second U-shaped guide member for guiding the movable element, said second U-shaped guide member being located opposite the first one and defining an open area therebetween for the passage of at least part of an edge holding portion of the packaged product, the movable element extending from the first U-shaped guide member to the second U-shaped guide member through said open area.

[0043] Preferably, the support body of each retention unit further comprises a frontal wall for guiding the at least one edge holding portion of the packaged product to the open area defined between the first and second U-shaped guide members.

[0044] According to the first aspect of the present invention, the support body of each retention unit may further comprise a frontal wall for guiding the at least one edge holding portion of the packaged product.

[0045] According to the first aspect of the present invention, the dispense actuator may be a magnetic linear actuator. Preferably, said dispense actuator is a bistable linear moving magnet. Alternatively, the dispense actuator is a spring return actuator. However, other kinds of actuators can also be used, as long as they are suitable for this purpose.

[0046] According to the first aspect of the present invention, the vending machine may further comprise an insulated chamber which houses therein the store structure and the corresponding dispensing mechanism.

[0047] Preferably, the insulated chamber is an insulated cooling chamber configured to keep the packaged products below a predetermined temperature or an insulated heating chamber configured to keep the packaged products above a predetermined temperature.

[0048] According to the first aspect of the present invention, the insulated chamber may comprise: an insulated door; a transport element for conveying the dispensed lowermost packaged product of a stack to a location outside the insulated chamber; and at least one sensor for detecting the presence of a packaged product on the transport element; and the control unit may be configured to open the insulated door when a packaged product is sensed on the transport element and to close the insulated door when no packaged product is sensed on the transport element.

[0049] According to the first aspect of the present invention, the transport element may be, for example, a conveyor belt and/or a chute.

[0050] According to the first aspect of the present invention, the store structure may be configured to store at least two rows of stacks following a first direction.

[0051] According to the first aspect of the present invention, the store structure may be configured to store at least two rows of stacks following a second direction, said second direction being perpendicular to said first direction.

[0052] According to the first aspect of the present invention, the vending machine may comprise a dispensing chute for conveying the dispensed lowermost product of a stack to the collection zone.

[0053] According to the first aspect of the present invention, the vending machine may comprise a conveyor belt for conveying the dispensed lowermost product of a stack to the collection zone.

[0054] According to the first aspect of the present invention, the collection zone may be accessible through an aperture in a front outer wall of the housing, and the aperture may be closed by an access door.

[0055] According to the first aspect of the present invention, the vending machine may comprise an input unit for selecting the packaged product to be dispensed and a Point-Of-Sale (POS) terminal for paying said selected packaged product.

[0056] According to the first aspect of the present invention, the vending machine may comprise at least one stack sensor for sensing the number of packaged products in the at least one vertical stack.

[0057] According to a second aspect of the present invention, it is disclosed a method for dispensing a packaged product from a vending machine comprising the steps of: providing a vending machine according to the first aspect of the present invention; loading at least one packaged product having opposed edge holding portions on a store structure for storing at least one stack of gravity lowered packaged products so that the opposed edge holding portions of the packaged product rest on corresponding retention units arranged in a retention position;

moving the retention units from the retention position to a dispensing position in which the opposed edge holding portions of the packaged product no longer rest on the retention units; letting at least the lowermost packaged product fall by gravity past the retention units; moving the retention units from the dispensing position to the retention position; optionally resting the opposed edge holding portions of the following lowermost packaged product of the stack on the retention units in the retention position.

[0058] In particular, according to a second aspect of the present invention, it is disclosed a method for dispensing a packaged product from a vending machine comprising the steps of: providing a vending machine according to the first aspect of the present invention; loading at least one packaged product having opposed edge holding portions on a store structure for storing at least one stack of gravity lowered packaged products so that the opposed edge holding portions of the packaged product rest on corresponding movable elements of retention units arranged in a retention position; moving the movable elements of the retention units from the retention position to a dispensing position, in which the opposed edge holding portions of the packaged product no longer rest on the retention units, following a backwards movement along a linear path; letting at least the lowermost packaged product fall by gravity past the movable elements of the retention units; moving the movable elements of the retention units from the dispensing position to the retention position following an advance movement along the linear path; and optionally resting the opposed edge holding portions of the following lowermost packaged product of the stack on the retention units in the retention position.

[0059] Preferably, said linear path is perpendicular to a longitudinal axis defined by the corresponding stack of gravity lowered packaged products, although it can also be inclined with respect to said longitudinal axis, i.e. not perpendicular or parallel.

[0060] According to the second aspect of the present invention, the method may further comprise the step of receiving the dispensed packaged product with a lowering mechanism and lowering it to a transport element for conveying the dispensed packaged product to the collection zone, or to a collection zone.

[0061] According to the second aspect of the present invention, the step of receiving the dispensed packaged product and lowering it to the transport element or to the collection zone may comprise the steps of: raising a movable platform to a receiving position; receiving the dispensed packaged product on the movable platform; lowering the movable platform with the dispensed packaged product to a discharging position; and discharging the dispensed packaged product to the transport element or to the collection zone.

[0062] According to the second aspect of the present invention, the step of discharging the dispensed packaged product may comprise the step of displacing the

lowering mechanism with the dispensed packaged product on the movable platform along a guide until the dispensed packaged product interferes with a stop that pushes the dispensed packaged product out of the movable platform. Alternatively, the step of discharging the dispensed packaged product may comprise the step of tilting the movable platform so that the dispensed packaged product falls by gravity.

[0063] According to the second aspect of the present invention, the method may further comprise the step of conveying the dispensed packaged product to a collection zone with a dispensing chute.

[0064] According to the second aspect of the present invention, the method may further comprise the step of transporting the dispensed packaged product with a conveyor belt to the collection zone or to an intermediate location.

[0065] According to the second aspect of the present invention, the method may further comprise the step of sensing the presence of the dispensed packaged product on the conveyor belt or on the dispensing chute and open an insulated door of an insulated chamber which houses therein the store structure.

[0066] According to the second aspect of the present invention, the method may further comprise the step of closing said insulated door once the dispensed packaged product is not sensed on the conveyor belt or on the dispensing chute.

[0067] According to the second aspect of the present invention, the method may further comprise the step of opening an access door closing an aperture through which the collection zone is accessible once a packaged product is sensed in the collection zone.

[0068] Unless otherwise provided, teachings in the context of the first aspect of the present invention also apply to the second aspect of the present invention, and vice versa.

[0069] It will be understood that references to geometric position, such as parallel, perpendicular, tangent, etc. allow deviations up to $\pm 5^\circ$ from the theoretical position defined by this nomenclature.

[0070] It will also be understood that any range of values given may not be optimal in extreme values and may require adaptations of the invention to these extreme values are applicable, such adaptations being within reach of a skilled person.

[0071] Other features of the invention will appear from the following detailed description of an embodiment.

Brief description of the Figures

[0072] The foregoing and other advantages and features will be more fully understood from the following detailed description of an embodiment with reference to the accompanying drawings, to be taken in an illustrative and non-limitative manner, in which:

Fig. 1 is a perspective view of a vending machine for

dispensing packaged products according to an embodiment of the present invention;

Fig. 2 is a diagrammatic partial side view showing an insulated chamber with an insulated door, a dispensing mechanism associated to a store structure storing several vertical stacks of packaged products, and a delivery conveyor belt of the vending machine; Fig. 3 is a diagrammatic partial front view showing the stacks of packaged products, the dispensing mechanism and the delivery conveyor belt of a first exemplary embodiment of a vending machine according to the present invention;

Fig. 4 is an enlarged detail of Fig. 3 showing a retention unit of the dispensing mechanism with a movable element thereof in a retention position;

Fig. 5 is an enlarged detail similar to Fig. 4 but with the movable element of the retention unit being moved to a dispensing position during a dispensing operation;

Fig. 6 is an enlarged detail similar to Fig. 4 but with the movable element of the retention unit being returned back to the retention position after the dispensing operation;

Fig. 7 is a perspective view of the store structure and the dispensing mechanism of a second exemplary embodiment of a vending machine according to the present invention;

Fig. 8 is a detail perspective view of the dispensing mechanism of the exemplary embodiment of a vending machine shown in Fig. 7;

Fig. 9 is an enlarged detail perspective view of the dispensing mechanism of the exemplary embodiment of a vending machine shown in Fig. 8;

Fig. 10 is a detail perspective view of the store structure and the dispensing mechanism of a third exemplary embodiment of a vending machine according to the present invention;

Fig. 11 is a perspective view of movable elements of the retention units of the exemplary embodiment of a vending machine shown in Fig. 10;

Fig. 12 is a perspective view of the lowering mechanism of the third exemplary embodiment of a vending machine; and

Fig. 13 is a detail side view of the lowering mechanism shown in Fig. 12.

Detailed description of an embodiment

[0073] Referring first to Fig. 1, the vending machine for dispensing packaged products according to one embodiment of a first aspect of the present invention comprises a housing 50 having a front outer wall 51 where one or more access openings 52 are formed. Each access opening 52 gives access to a collection zone 7 from which a user can take a packaged product 40 once it has been dispensed by a dispensing mechanism 22 located inside the housing 50. An access door 6 is manually operable to open and close the access opening 52.

[0074] In an alternative embodiment (not shown), an actuator is configured and arranged to automatically open and close access door 6 when a packaged product 40 is detected in the collection zone 7 by a sensor.

[0075] The front outer wall 51 of the vending machine housing 50 further comprises an input unit 53 for enabling the user to select the kind of packaged product 40 to be dispensed and a Point-Of-Sale terminal 54 for enabling the user to pay the selected packaged product 40.

[0076] As shown in Fig. 2, inside the housing 50 of the exemplary embodiment shown there is an insulated chamber 16 which houses therein a store structure 15 configured for storing one or several vertical stacks of gravity dischargeable packaged products 40, the corresponding dispensing mechanism 22 which is configured for supporting the stacks of packaged products 40 and for dispensing the lowermost packaged product 40 of a selected one of the stacks, and a conveyor belt 10 located below the dispensing mechanism 22 to receive the dispensed packaged products 40. The conveyor belt 10 is driven by a conveyor actuator 21 (shown in Fig. 3) for conveying the dispensed lowermost product 40 to a location outside the insulated chamber 16.

[0077] In one embodiment, the insulated chamber 16 is an insulated cooling chamber configured to keep the packaged products 40 below a predetermined temperature. In an alternative embodiment, the insulated chamber 16 is an insulated heating chamber configured to keep the packaged products 40 above a predetermined temperature. In an alternative embodiment, the housing 50 comprises a first insulating chamber 16 being an insulated heating chamber as previously described, and a second insulating chamber 16 being an insulated cooling chamber, as previously described. Such kind of arrangements are especially useful for dispensing packaged food products, as food products typically need to be stored in a cool or warm environment. However, such arrangements are also suitable for dispensing other types of packaged products, for example, medicines.

[0078] The insulated chamber 16 comprises an insulating inner wall 2 parallel to and spaced apart from the front outer wall 51. The collection zone 7 of this exemplary embodiment is provided by a tray 20 arranged in a space between the insulating inner wall 2 and the front outer wall 51. The insulating inner wall 2 has an insulated door 4 adjacent to one end of the conveyor belt 10. The insulated door 4 is movable, for example by pivoting about a hinge 19, between a closed position and an open position. A door actuator (not shown) is operatively arranged to open and close the insulated door 4.

[0079] The insulated door 4 has a passage opening with a downwards and outwards inclined bottom edge that forms an intermediate chute 18. The tray 20 in the collection zone 7 extends from the intermediate chute 18 to slightly below the access opening 52 in the front outer wall 51 of the housing 50 and is preferably also inclined downwards and outwards.

[0080] In operation, once a user has selected a desired

kind of packaged product 40 by using the input unit 53 and has paid the corresponding amount by using Point-Of-Sale terminal 54, a control unit of the machine sends a control signal to the dispensing mechanism 22 to drop the lowermost packaged product 40 of the corresponding stack while retaining the remaining packaged products 40 in the stack. So, the dropped packaged product 40 falls by gravity on the conveyor belt 10.

[0081] Then, once the presence of the packaged product 40 on the conveyor belt 10 is detected by a conveyor sensor 14 configured and arranged for that purpose, the control unit sends a control signal to the door actuator to open the insulated door 4 and to the conveyor actuator 21 so that the conveyor belt 10 conveys the packaged product 40 outside the insulated chamber 16 through the intermediate chute 18 and to the tray 20 in the collection zone 7. The user can then take the dispensed packaged product 40 accessing the collection zone 7 through the corresponding access opening 52 in the front outer wall 51 of the housing 50.

[0082] Alternatively, the conveyor actuator 21 of the conveyor belt 10 can be activated by the same control signal that activates the dispensing mechanism 22. The control unit sends a control signal to the door actuator to close the insulated door 4 and to the conveyor actuator 21 to stop the conveyor belt 10 when no packaged product 40 is sensed on the conveyor belt 10.

[0083] In an alternative embodiment (not shown), the conveyor belt 10 is replaced by a dispensing chute inclined downwards to the insulated door 4, or directly to the access opening 52 if no insulated chamber is provided, with an equivalent result since the dispensed packaged product 40 slips down the dispensing chute by gravity to the insulated door 4 or to the access opening 52 and thereby no conveyor actuator is needed.

[0084] The store structure 15 may be configured to store a single stack of packaged products 40 (not shown) or an array of stacks of packaged products 40, as can be seen in Figs. 2 and 3, and in Figs. 7 and 8. In the embodiment shown, the store structure 15 is configured to store three rows of stacks following a first direction (Fig. 2) and two rows of stacks following a second direction (Fig. 3), with the second direction being perpendicular to the first direction. Fig. 7 also shows an embodiment of a vending machine according to the present invention comprising three rows of stacks following a first direction and two rows of stacks following a second direction perpendicular to said first direction. The number of rows in either direction may be varied according to the dimensions of the packaged products 40 to be stored and/or to the dimensions of the housing 50.

[0085] When multiple stacks of packaged products 40 are provided, different kinds of packaged products 40 can be dispensed provided that the packaged products 40 in each stack are of the same kind and have the same dimensions. However, different kinds of packaged products 40 can also have different dimensions provided that they have opposed edge holding portions 41. In this case,

the dispensing mechanism 22 of each stack will be adapted to the dimensions of the packaged products 40 in that stack.

[0086] Referring now to Fig. 3 to 6, the dispensing mechanism 22 of the first exemplary embodiment comprises two retention units 11 arranged on opposite sides of each vertical stack of packaged products 40. Each retention unit 11 comprises a support body 30 fixed to a machine frame (not shown), a movable element 31 and a dispensing actuator 32 configured and arranged for moving the movable element 31 between a retention position and a dispensing position.

[0087] In the retention position (better shown in Fig. 4), the movable elements 31 of the corresponding two retention units 11 interfere with the two opposed edge holding portions 41 of the lowermost packaged product 40.1 of the stack so that this lowermost packaged product 40.1 is retained and the remaining packaged products 40 of the stack rest on one another and on the lowermost packaged product 40.

[0088] In the dispensing position (Fig. 5), the corresponding two movable elements 31 are withdrawn so that they do not interfere with the two opposed edge holding portions 41 of the lowermost packaged product 40.1 of the stack thereby this lowermost packaged product 40.1 falls by gravity onto the conveyor belt.

[0089] However, as shown in Fig. 6, the movable elements 31 are returned back to the retention position quickly enough to interfere with the opposed edge holding portions 41 of the next packaged product 40.2 of the stack so that only one packaged product 40.1, namely the lowermost one, is delivered.

[0090] In order to perform a dispensing operation, the control unit of the vending machine is configured to send control signals to the dispensing actuator 32 so as to drive the movable elements 31 of the retention units 11 from the retention position (Fig. 4) to the dispensing position (Fig. 5) and to quickly return the movable elements 31 of the retention units 11 back to the retention position (Fig. 6) in order to interfere with the edge holding portions 41 of the next packaged product 40.2 in the stack.

[0091] The time interval lapsed from the dispensing position back to the retention position of the movable elements 31 is selected to be less than the time spent for the next packaged product 40.2 in the stack to fall by gravity a distance equivalent to its own height, so that the next packaged product 40.2 in the stack is retained then in the lowermost position by the movable elements 31.

[0092] Optionally, the time interval lapsed from the dispensing position back to the retention position of the movable elements 31 may be regulated in order to enable the delivery of more than one packaged product 40 of the stack in a single dispensing operation.

[0093] The movable elements 31 move from the retention position to the dispensing position following a backwards movement along a linear path and move from the

dispensing position to the retention position following an advance movement along the linear path. In this exemplary embodiment, the path followed by the movable elements 31 is perpendicular to a longitudinal axis defined by the stack of gravity lowered packaged products. However, in other embodiments said path may be inclined in respect to said longitudinal axis of the stack. In this exemplary embodiment, said longitudinal axis defined by the stack of gravity lowered packaged products is vertical. In this exemplary embodiment, the linear path is defined by the U-shaped guide members 33.

[0094] Fig. 7 shows the store structure 15 for storing at least one vertical stack of gravity lowered packaged products 40 and the dispensing mechanism 22 for supporting a corresponding stack of gravity lowered packaged products 40 and dispensing the lowermost packaged product 40 of said stack, of a second exemplary embodiment of a vending machine according to the present invention.

[0095] As can be seen, the store structure 15 of this second exemplary embodiment is configured to store three rows of stacks following a first direction and two rows of stacks following a second direction perpendicular to said first direction. In order to guide each vertical stack of gravity lowered packaged products 40, the store structure 15 of this exemplary embodiment comprises four guides 63 for each stack, each guide 63 having a substantially cylindrical shape. In other embodiments the guides 63 can have a different shape, for example, can be of a substantially quadrangular prismatic shape, planar, etc. Other embodiments can comprise a different number of guides 63 for each stack, although at least one guide for each side of the packaged product 40 is preferred. Each guide 63 can be easily attached or removed from the store structure 15 in order to, for example, ease maintenance operations.

[0096] The dispensing mechanism 22 of this second exemplary embodiment comprises two retention units 11 arranged on opposite side of each vertical stack. Similar to the exemplary embodiments previously shown, each retention unit 11 comprises a support body 30, a movable element 31 and a dispense actuator 32 for moving the movable element from a retention position to a dispensing position and vice versa.

[0097] In the exemplary embodiment shown, the support body 30 is common for each row of retention units 11. However, in other embodiment each retention unit 11 could have its own support body 30. The support body 30 shown comprises a frontal wall 35 for guiding the at least one edge holding portion 41 of the packaged product 40 and further comprises a sloped wall 38 adjacent to the frontal wall 35. Said sloped wall 38 is optional and is configured to guide the packaged products 40 to the frontal wall 35.

[0098] Said frontal wall 35 comprises at least one opening 60 for the passage of at least part of the movable element 31, so that said movable element 31 can move from its retention position to its dispensing position, and

vice versa. Movable elements 31 are driven by associated dispensing actuators 32 that, in this exemplary embodiment, are operatively connected to the corresponding movable element 31 by a shank 36.

[0099] The support structure 15 shown further comprises two lateral guides 64 arranged on the lowermost part of the support structure 15 to further guide the major lateral sides of the lowermost packaged product 40 of the stack so that the retention units 11 can effectively support the stack of packaged products 40 and dispense the lowermost packaged product 40 of said stack. Said lateral guides 64 are optional and at least one guide 64 for each lateral major side of the stack would suffice. The frontal wall 35 guides the lateral minor lateral sides of the stack of packaged products 40.

[0100] Figs. 8 and 9 show a detail perspective view of the dispensing mechanism 22 of the exemplary embodiment of a vending machine shown in FIG. 7.

[0101] In this exemplary embodiment the at least one opening 60 for the passage of at least part of the movable element 31 is defined by three separate openings 60A, 60B, 60C adjacent one another and arranged in a linear manner. The openings 60A, 60B, 60C are separated by corresponding intermediate regions 61, which, in this exemplary embodiment, interfere with the advance movement of the movable element 31, acting as a stop defining the retention position of the corresponding movable element 31.

[0102] The at least one opening 60 besides allowing passage of at least part of the movable element 31 so that it can reach its retention position wherein it interferes with an edge holding portion 41 of the lowermost packaged product 40 of the stack, can also act as a support of said movable element 31, preventing the movable element 31 and the shank 36 of the associated dispensing actuator 32 to flex excessively, as the movable element 31 and/or the shank 36 can rest on the edge of the at least one opening 60. An excessive flexion of the movable element 31 and/or of the shank 36 of the dispensing actuator 32 should be avoided as it could break them or, at least, reduce its lifespan. This also applies when said at least one opening 60 is divided into two or more separate openings 60A, 60B, 60C.

[0103] As can be seen in greater detail in Fig. 9, in this exemplary embodiment the movable element 31 comprises one notch or recess 39 for each intermediate region 61 of the corresponding opening 60, thereby allowing passage of at least part of the movable element 31 through the openings 60A, 60B, 60C so that the movable element 31 can reach its retaining position. Said intermediate region 61 act as a stop against the corresponding recess 39 interfering with the advance movement of the movable element 31, thereby limiting the travel of the movable element 31 and defining its retention position. Said recesses 39 do not affect the retention ability of the movable element 31. Said intermediate region 61 does not affect the backwards movement of the movable element 31 from the retention position to the dispensing po-

sition.

[0104] In this exemplary embodiment, the central opening 60B comprises a substantially cylindrical indentation 62 for the passage of the shank 36 of the dispensing actuator 32. In other embodiments said indentation 62 may have a different shape or may not be present, depending, among others, on the shape of the shank 36 and the attachment of the movable element 31 to the corresponding shank 36.

[0105] The detail view of Fig. 8 also shows in great detail the lateral guides 64, as well as the fastening of the guides 63 to the chassis of the store structure 15.

[0106] Fig. 10 shows a detail perspective view of the store structure 15 and the dispensing mechanism 22 of a third exemplary embodiment of a vending machine according to the present invention.

[0107] In this exemplary embodiment the at least one opening 60 for the passage of at least part of the movable element 31 is defined by four separate openings 60A, 60B, 60C, 60D adjacent one another and arranged in a linear manner and separated by three intermediate regions 61.

[0108] The movable elements 31 of the third exemplary embodiment comprises two protrusions 38, one at each longitudinal end thereof, that act as a guide of the movable element 31 when it moves through the opening 60, in this case, openings 60A, 60B, 60C, 60D. The protrusions 38, ensure that the movable element 31 is maintained aligned with the corresponding opening 60 and are shaped so that they do not interfere with the dispensing and retention capability of the movable element 31. Although two protrusions 38 are preferred, one at each longitudinal end of the movable element 31, a single protrusion 38 could also suffice. The protrusions 38 extend towards the corresponding stack of gravity lowered packaged products 40.

[0109] In this exemplary embodiment, the central openings 60B, 60C comprise a substantially cylindrical indentation 62 for avoiding interference of the shank 36 of the dispensing actuator 32 with the frontal wall 35. As both the central openings 60B, 60C comprise the indentation 62, although in this case only one would suffice as the dispensing actuator 62 comprises a single shank 36, the same frontal wall 35 can be used at either side of the stack of gravity lowered packaged products 40 (see Fig. 11 for better understanding).

[0110] In a similar manner to what has been previously described in the context of Fig. 9, the intermediate regions 61 interfere with the distal surface 390 of the corresponding recess 39 when the movable element 31 advances towards the stack of gravity lowered packaged products 40, thereby defining the retention position of the movable element 31.

[0111] As in the exemplary embodiment shown in Figs. 7 to 9, in this exemplary embodiment the movable elements 31 move from the retention position to the dispensing position following a backwards movement along a linear path that is perpendicular to the longitudinal axis

defined by the corresponding stack of gravity lowered packaged products 40; and move from the dispensing position to the retention position following an advance movement along said linear path. In this regard, the openings 60A, 60B, 60C, 60D aid in guiding the movement of the movable element 31.

[0112] Located between two stacks of gravity lowered packaged products 40, in this exemplary embodiment are located the dispensing actuators 32 of movable elements 31 of opposed stacks of gravity lowered packaged products 40. This arrangement is clearly shown in Fig. 11 that shows a perspective view of movable elements and corresponding dispensing actuators arranged between opposing stacks of gravity lowered packaged products 40 of the exemplary embodiment shown in Fig. 10.

[0113] The perspective view of Fig. 11 allows to clearly see the shape of the movable elements 31 of this exemplary embodiment. In this exemplary embodiment, each movable element 31 comprises three notches or recesses 39, one for each intermediate region 61 shown in Fig. 10. The recesses 39 closer to the longitudinal ends of the movable element 31 are wider than the central recess 39, as the central intermediate region 61 is narrower than the other two. However, in other embodiments, all recesses 39 and intermediate regions 61 can have the same dimensions or have the recesses 39 having different dimensions arranged in a different manner, for example, the central recess 39, and corresponding intermediate region 61, being wider than the ones closer to the longitudinal ends of the movable element 31.

[0114] Each recess 39 of this exemplary embodiment comprises a distal surface 390 and lateral surfaces 391 extending towards said distal surface 390 in a convergent manner, that is to say, the recess 39 narrows towards the distal surface 390. This shape prevents the lateral surfaces 391 to get stuck with the intermediate regions 61 which could prevent the movable element 31 from reaching its retention position.

[0115] At opposite longitudinal edges, the movable elements 31 of this exemplary embodiment comprise a protrusion extending towards the corresponding stack of gravity lowered packaged products 40 that guide the movable element 31 when moving in a backwards or advance direction through the corresponding opening 60, 60A, 60D.

[0116] The movable elements 31 shown comprise two connection orifices 37 for connecting the shank 36 of the dispensing actuator 32 to the movable element 31. The movable elements 31 shown comprise two connection orifices 37 as this makes them reversible and can be used in either side of the stack of gravity lowered packaged products 40, thus reducing the number of different pieces of the vending machine.

[0117] Between the connection orifice 37 and the dispensing actuator 32 the movable element 31 comprises a recess that allows the movable element 31 to be arranged closer to the dispensing actuator 32 and, thus,

provide a more compact arrangement of the store structure 15 and of the vending machine.

[0118] The different elements or parts of the movable elements 31 shown in Fig. 11 are symmetrical with respect to a transversal axis of symmetry.

[0119] Figs. 12 and 13 show a perspective and a side view, respectively, of a lowering mechanism of the third exemplary embodiment of a vending machine according to the present invention shown in Figs. 10 and 11.

[0120] Certain packaged products 40 can be damaged if they fall from the stack of gravity lowered packaged products 40 from a certain height. This depends on the height from the lowermost packaged product 40 of the stack and on the type of product stored therein. However, there are other reasons to avoid a fall from a certain height of a dispensed packaged product 40, as for example, a reduction of the noise produced by the impact. In conclusion, there are a number of reasons to avoid a fall of the dispensed product 40 from a certain height. In order to solve this problem, embodiments of the vending machine according to the present invention can comprise a lowering mechanism 70 for receiving the dispensed packaged product 40 and lowering it to a transport element for conveying said packaged product 40 to the collection 7, or directly to the collection zone 7 (see, for example, Fig. 1).

[0121] The lower mechanism 70 shown in Figs. 12 and 13 comprises a movable platform 71 that is configured to be raised to a receiving position, in which it receives the dispensed packaged product 40, and to be lowered to a discharging position, in which the dispensed packaged product 40 is discharged to the transport element or directly to the collection zone 7. In Fig. 12 the movable platform 71 is depicted in its receiving position, whereas in Fig. 13 said movable platform 71 is depicted in its discharging position.

[0122] In order to raise and lower the movable platform, the lowering mechanism 70 comprises a driving unit 72 that, in the exemplary embodiment shown, can slide along a guide 73.

[0123] The optional discharging ramps 74 depicted in Figs. 12 and 13 aid in dampening the fall of the packaged product 40 (not shown) from the movable platform to the transport element or to the collection zone 7. Moreover, said discharging ramps 74 also guide the fall of the packaged product 40 from the movable platform 71 to the transport element or to the collection zone 7. Although in the exemplary embodiment shown the lowering mechanism 70 comprises two discharging ramps 74, in other embodiments the lowering mechanism can comprise a different number of discharging ramps 74, for example, one, three, etc. Said discharging ramp 74 is optional and other embodiments may lack such element.

[0124] In order to discharge the packaged product 40 from the movable platform 71, in this exemplary embodiment, the driving unit 72 moves along the guide 73 until it reaches a stop that interferes with the packaged product 40 located on the movable platform 71, so that the pack-

aged product 40 is pushed out of the movable platform 71 and falls to the collection zone 7 or the transport element guided by the discharge ramps 74. However, in other embodiments the movable platform can be configured to tilt, so that by tilting the movable platform the packaged product 40 falls from it. Other arrangements for discharging the packaged product 40 from the movable platform are also possible within the scope of the present invention.

[0125] The dispensing actuator 32 in the exemplary embodiments shown above is a magnetic linear actuator which is able to impart a quick movement to the movable element 31. Examples of useful magnetic linear actuators are a bistable linear moving magnet and a spring return actuator comprising, for example, an electromagnet arranged to perform the movement of the movable element from the retaining position to the dispensing position in cooperation with a spring arranged to return the movable element back to the retaining position.

[0126] According to a second aspect, the present invention provides a method for dispensing a packaged product 40 from a vending machine comprising the essential features of the vending machine described above.

[0127] The method comprises the following steps:

initially, loading at least one packaged product 40 having opposed edge holding portions 41 on a store structure 15 for storing at least one stack of gravity lowered packaged products 40 so that the opposed edge holding portions 41 of the packaged product 40 rest on movable elements 31 of corresponding retention units 11 arranged in a retention position; then, moving the movable elements 31 of the retention units 11 from the retention position to a dispensing position in which the opposed edge holding portions 41 of the packaged product 40 no longer rest on the movable elements 31 of the retention units 11; subsequently, letting at least the lowermost packaged product 40 of the stack to fall by gravity past the retention units 11; and finally, moving the movable elements 31 of the retention units 11 from the dispensing position back to the retention position.

[0128] Optionally, if there were more than one packaged product 40 in the stack, the method then comprises resting the opposed edge holding portions 41 of the following lowermost packaged product 40 of the stack on the movable elements 31 of the retention units 11 which are back in the retention position.

[0129] Also envisaged with the method is the optional step of conveying the dispensed packaged product 40 either with a dispensing chute or with a conveyor belt 10 to a collection zone 7 or to an intermediate location.

[0130] Where either the dispensing chute or the conveyor belt 10 is used, the method optionally comprises the step of sensing the presence of the dispensed packaged product 40 on the dispensing chute or on the con-

veyor belt 10 and open an insulated door 4 of an insulated chamber 16 which houses therein the store structure 15, and a further step of closing said insulated door 4 once the dispensed packaged product 40 is no longer sensed on the dispensing chute or on the conveyor belt 10.

[0131] Optionally, the method further comprises the step of opening an access door 6 closing an access opening 52 through which the collection zone 7 is accessible from the outside once a packaged product 40 is sensed in the collection zone 7.

[0132] The vending machines for dispensing packaged products, as well as the methods for dispensing a packaged product, previously described are specially envisaged for dispensing packaged food products, but any other suitable packaged product could also be dispensed.

[0133] The vending machines and the method object of the present invention can also dispense non packaged products by previously placing said non packaged product in a package 40 having opposed edge holding portions 41 as the ones shown in Fig. 7, for example.

[0134] The scope of the invention is defined in the attached claims.

Claims

1. Vending machine for dispensing packaged products, each one of said packaged products (40) having opposed edge holding portions (41), said vending machine having a housing (50) which comprises:

- a collection zone (7) for a dispensed packaged product (40);
 - a store structure (15) for storing at least one vertical stack of gravity lowered packaged products (40), each vertical stack of gravity lowered packaged products (40) defining a longitudinal axis;
 - a dispensing mechanism (22) for supporting a corresponding stack of gravity lowered packaged products (40) and dispensing the lowermost packaged product (40) of said stack; the dispensing mechanism (22) comprising at least two retention units (11) arranged on opposite sides of the vertical stack, each retention unit (11) having a retention position for interfering with an edge holding portion (41) of the lowermost packaged product (40) of the stack and a dispensing position for releasing said edge holding portion (41) of said lowermost packaged product (40);
- the vending machine further comprising a control unit configured to drive the retention units (11) from the retention position to the dispensing position and to return the retention units (11) to the retention position from the dispensing position once at least said lowermost packaged

product (40) of the stack has fallen by gravity; each retention unit (11) comprising a support body (30), a movable element (31) and a dispense actuator (32) for moving the movable element (31) from a retention position to a dispensing position and vice versa;

characterized in that each movable element (31) is configured to move from the retention position to the dispensing position following a backwards movement along a linear path, and to move from the dispensing position to the retention position following an advance movement along the linear path.

2. Vending machine, according to claim 1, **characterised in that** the linear path is perpendicular to the longitudinal axis defined by the corresponding stack of gravity lowered packaged products (40).
3. Vending machine, according to claim 1 or 2, **characterised in that** the support body (30) comprises a frontal wall (35) for guiding the at least one edge holding portion (41) of the packaged product (40).
4. Vending machine, according to claim 3, **characterised in that** the frontal wall (35) comprises at least one opening (60) for the passage of at least part of the movable element (31).
5. Vending machine, according to claim 4, **characterised in that** the frontal wall (35) comprises two or more openings (60A, 60B, 60C, 60D) for the passage of two or more parts (31A, 31B, 31C) of the corresponding movable element (31).
6. Vending machine, according to claim 5, **characterised in that** adjacent openings (60A, 60B, 60C, 60D) are separated by an intermediate region (61), each intermediate region (61) interfering with the advance movement of the movable element (31) to define its retention position.
7. Vending machine, according to claim 6, **characterised in that** the movable element (31) comprises a recess (39) for each intermediate region (61), each recess having a distal surface (390) for interfering with the corresponding intermediate region (61), acting as a stop of the movable element (31) and defining the retention position thereof.
8. Vending machine, according to claim 7, **characterised in that** the recess (39) has two lateral surfaces (391) extending towards the distal surface (390) in a convergent manner.
9. Vending machine, according to any one of claims 6 to 8, **characterised in that** the intermediate region (61) is part of the frontal wall (35).

10. Vending machine, according to any one of the preceding claims, **characterised in that** the movable element (31) comprises at opposite longitudinal ends thereof a protrusion (38) for guiding the movable element (31) through the corresponding opening (60, 60A, 60B, 60C, 60D). 5
11. Vending machine, according to any one of the preceding claims, **characterised in that** it further comprises a lowering mechanism (70) for receiving the dispensed packaged product (40) and lowering it to a transport element for conveying the dispensed packaged product (40) to the collection zone (7), or to the collection zone (7). 10
12. Vending machine, according to claim 11, **characterised in that** the lowering mechanism (70) comprises a movable platform (71) configured for raising to a receiving position, in which it receives the dispensed packaged product (40), and for lowering to a discharging position, in which the dispensed packaged product (40) is discharged to the transport element or to the collection zone (7). 15 20
13. Method for dispensing a packaged product (40) from a vending machine comprising the steps of: 25
- providing a vending machine according to any one of claims 1 to 12;
 - loading at least one packaged product (40) having opposed edge holding portions (41) on a store structure (15) for storing at least one stack of gravity lowered packaged products (40) so that the opposed edge holding portions (41) of the packaged product (40) rest on corresponding movable elements (31) of retention units (11) arranged in a retention position; 30
 - moving the movable elements (31) of the retention units (11) from the retention position to a dispensing position, in which the opposed edge holding portions (41) of the packaged product (40) no longer rest on the retention units (11), following a backwards movement along a linear path; 35
 - letting at least the lowermost packaged product (40) fall by gravity past the movable elements (31) of the retention units (11); 40
 - moving the movable elements (31) of the retention units (11) from the dispensing position to the retention position following an advance movement along the linear path; 45
 - optionally resting the opposed edge holding portions (41) of the following lowermost packaged product (40) of the stack on the retention units (11) in the retention position. 50
14. Method, according to claim 13, further comprising the step of receiving the dispensed packaged prod-

uct (40) with a lowering mechanism (70) and lowering it to a transport element for conveying the dispensed packaged product (40) to the collection zone (7), or to a collection zone (7).

15. Method, according to claim 14, wherein the step of receiving the dispensed packaged product (40) and lowering it to the transport element or to the collection zone (7) comprises the steps of:

- raising a movable platform (71) to a receiving position;
- receiving the dispensed packaged product (40) on the movable platform (71);
- lowering the movable platform (71) with the dispensed packaged product (40) to a discharging position; and
- discharging the dispensed packaged product (40) to the transport element or to the collection zone (7).

Patentansprüche

1. Verkaufsautomat zum Ausgeben von verpackten Produkten, wobei jedes der verpackten Produkte (40) gegenüberliegende Kantenhalteabschnitte (41) aufweist, wobei der Verkaufsautomat ein Gehäuse (50) aufweist, das Folgendes umfasst: 25
- eine Sammelzone (7) für ein ausgegebenes verpacktes Produkt (40); 30
 - eine Speicherstruktur (15) zum Speichern mindestens eines vertikalen Stapels von durch Schwerkraft abgesenkten verpackten Produkten (40), wobei jeder vertikale Stapel von durch Schwerkraft abgesenkten verpackten Produkten (40) eine Längsachse definiert; 35
 - einen Ausgabemechanismus (22) zum Tragen eines entsprechenden Stapels von durch Schwerkraft abgesenkten verpackten Produkten (40) und zum Ausgeben des untersten verpackten Produkts (40) des Stapels; wobei der Ausgabemechanismus (22) mindestens zwei Rückhalteeinheiten (11) umfasst, die an gegenüberliegenden Seiten des vertikalen Stapels angeordnet sind, wobei jede Rückhalteeinheit (11) eine Rückhalteposition zum Eingreifen in einen Kantenhalteabschnitt (41) des untersten verpackten Produkts (40) des Stapels und eine Ausgabeposition zum Freigeben des Kantenhalteabschnitts (41) des untersten verpackten Produkts (40) aufweist; 40
 - wobei der Verkaufsautomat ferner eine Steuereinheit umfasst, die dazu konfiguriert ist, die Rückhalteeinheiten (11) aus der Rückhalteposition in die Ausgabeposition zu fahren und die Rückhalteeinheiten (11) aus der Ausgabeposi-

- tion in die Rückhalteposition zurückzuführen, sobald mindestens das unterste verpackte Produkt (40) des Stapels durch Schwerkraft gefallen ist;
wobei jede Rückhalteeinheit (11) einen Tragkörper (30), ein bewegliches Element (31) und ein Ausgabestellglied (32) umfasst, um das bewegliche Element (31) von einer Rückhalteposition in eine Ausgabeposition und umgekehrt zu bewegen;
dadurch gekennzeichnet, dass jedes bewegliche Element (31) dazu konfiguriert ist, sich von der Rückhalteposition in die Ausgabeposition im Zuge einer Rückwärtsbewegung entlang eines linearen Pfades zu bewegen, und sich von der Ausgabeposition in die Rückhalteposition im Zuge einer Vorschubbewegung entlang des linearen Pfades zu bewegen.
2. Verkaufsautomat nach Anspruch 1, **dadurch gekennzeichnet, dass** der lineare Pfad senkrecht zu der Längsachse verläuft, die durch den entsprechenden Stapel von durch Schwerkraft abgesenkten verpackten Produkten (40) definiert ist.
 3. Verkaufsautomat nach Anspruch 1 oder 2, **dadurch gekennzeichnet, dass** der Tragkörper (30) eine Stirnwand (35) zum Führen des mindestens einen Kantenhalteabschnitts (41) des verpackten Produkts (40) umfasst.
 4. Verkaufsautomat nach Anspruch 3, **dadurch gekennzeichnet, dass** die Stirnwand (35) mindestens eine Öffnung (60) für den Durchgang von mindestens einem Teil des beweglichen Elements (31) umfasst.
 5. Verkaufsautomat nach Anspruch 4, **dadurch gekennzeichnet, dass** die Stirnwand (35) zwei oder mehr Öffnungen (60A, 60B, 60C, 60D) für den Durchgang von zwei oder mehr Teilen (31A, 31B, 31C) des entsprechenden beweglichen Elements (31) umfasst.
 6. Verkaufsautomat nach Anspruch 5, **dadurch gekennzeichnet, dass** benachbarte Öffnungen (60A, 60B, 60C, 60D) durch einen Zwischenbereich (61) getrennt sind, wobei jeder Zwischenbereich (61) in die Vorschubbewegung des beweglichen Elements (31) eingreift, um dessen Rückhalteposition zu definieren.
 7. Verkaufsautomat nach Anspruch 6, **dadurch gekennzeichnet, dass** das bewegliche Element (31) eine Aussparung (39) für jeden Zwischenbereich (61) umfasst, wobei jede Aussparung eine distale Oberfläche (390) zum Eingreifen in den entsprechenden Zwischenbereich (61) aufweist, die als ein Anschlag des beweglichen Elements (31) wirkt und dessen Rückhalteposition definiert.
 8. Verkaufsautomat nach Anspruch 7, **dadurch gekennzeichnet, dass** die Aussparung (39) zwei Seitenoberflächen (391) aufweist, die sich konvergierend in Richtung der distalen Oberfläche (390) erstrecken.
 9. Verkaufsautomat nach einem der Ansprüche 6 bis 8, **dadurch gekennzeichnet, dass** der Zwischenbereich (61) Teil der Stirnwand (35) ist.
 10. Verkaufsautomat nach einem der vorhergehenden Ansprüche, **dadurch gekennzeichnet, dass** das bewegliche Element (31) an seinen gegenüberliegenden Längsenden einen Vorsprung (38) umfasst, um das bewegliche Element (31) durch die entsprechende Öffnung (60, 60A, 60B, 60C, 60D) zu führen.
 11. Verkaufsautomat nach einem der vorhergehenden Ansprüche, **dadurch gekennzeichnet, dass** er ferner einen Absenkmechanismus (70) zum Aufnehmen des ausgegebenen verpackten Produkts (40) und zum Absenken desselben auf ein Transportelement, um das ausgegebene verpackte Produkt (40) zur Sammelzone (7) zu befördern, oder zur Sammelzone (7) umfasst.
 12. Verkaufsautomat nach Anspruch 11, **dadurch gekennzeichnet, dass** der Absenkmechanismus (70) eine bewegliche Plattform (71) umfasst, die dazu konfiguriert ist, sich in eine Aufnahmeposition zu heben, in der sie das ausgegebene verpackte Produkt (40) aufnimmt, und sich in eine Abgabeposition abzusenken, in der das ausgegebene verpackte Produkt (40) auf das Transportelement oder in die Sammelzone (7) abgegeben wird.
 13. Verfahren zum Ausgeben eines verpackten Produkts (40) aus einem Verkaufsautomaten, umfassend die folgenden Schritte:
 - Bereitstellen eines Verkaufsautomaten nach einem der Ansprüche 1 bis 12;
 - Laden mindestens eines verpackten Produkts (40), das gegenüberliegende Kantenhalteabschnitte (41) aufweist, auf eine Speicherstruktur (15) zum Speichern mindestens eines Stapels von durch Schwerkraft abgesenkten verpackten Produkten (40), so dass die gegenüberliegenden Kantenhalteabschnitte (41) des verpackten Produkts (40) auf entsprechenden beweglichen Elementen (31) von Rückhalteeinheiten (11) aufliegen, die in einer Rückhalteposition angeordnet sind;
 - Bewegen der beweglichen Elemente (31) der Rückhalteeinheiten (11) aus der Rückhaltepo-

- sition in eine Ausgabeposition, in der die gegenüberliegenden Kantenhalteabschnitte (41) des verpackten Produkts (40) nicht mehr auf den Rückhalteeinheiten (11) aufliegen, im Zuge einer Rückwärtsbewegung entlang eines linearen Pfades;
- Zulassen, dass mindestens das unterste verpackte Produkt (40) durch die Schwerkraft an den beweglichen Elementen (31) der Rückhalteeinheiten (11) vorbeifällt;
 - Bewegen der beweglichen Elemente (31) der Rückhalteeinheiten (11) von der Ausgabeposition in die Rückhalteposition im Zuge einer Vorschubbewegung entlang des linearen Pfades;
 - gegebenenfalls Auflegen der gegenüberliegenden Kantenhalteabschnitte (41) des folgenden untersten verpackten Produkts (40) des Stapels auf die Rückhalteeinheiten (11) in der Rückhalteposition.
14. Verfahren nach Anspruch 13, ferner umfassend den Schritt des Aufnehmens des ausgegebenen verpackten Produkts (40) mit einem Absenkmechanismus (70) und des Absenkens desselben auf ein Transportelement, um das ausgegebene verpackte Produkt (40) zur Sammelzone (7) zu befördern, oder zu einer Sammelzone (7).
15. Verfahren nach Anspruch 14, wobei der Schritt des Aufnehmens des ausgegebenen verpackten Produkts (40) und des Absenkens desselben auf das Transportelement oder zur Sammelzone (7) die folgenden Schritte umfasst:
- Anheben einer beweglichen Plattform (71) in eine Aufnahmeposition;
 - Aufnehmen des ausgegebenen verpackten Produkts (40) auf der beweglichen Plattform (71);
 - Absenken der beweglichen Plattform (71) mit dem ausgegebenen verpackten Produkt (40) in eine Abgabeposition; und
 - Abgeben des ausgegebenen verpackten Produkts (40) an das Transportelement oder an die Sammelzone (7).

Revendications

1. Distributeur automatique pour distribuer de produits emballés, chacun desdits produits emballés (40) ayant des parties de maintien de bord opposées (41), ledit distributeur automatique ayant un boîtier (50) qui comprend :
- une zone de collecte (7) pour un produit emballé distribué (40) ;
 - une structure de stockage (15) pour stocker au

moins une pile verticale de produits emballés abaissés par gravité (40), chaque pile verticale de produits emballés abaissés par gravité (40) définissant un axe longitudinal ;

- un mécanisme de distribution (22) pour supporter une pile correspondante de produits emballés abaissés par gravité (40) et distribuer le produit emballé le plus bas (40) de ladite pile ; le mécanisme de distribution (22) comprenant au moins deux unités de rétention (11) disposées sur des côtés opposés de la pile verticale, chaque unité de rétention (11) ayant une position de rétention pour interférer avec une partie de maintien de bord (41) du produit emballé le plus bas (40) de la pile et une position de distribution pour libérer ladite partie de maintien de bord (41) dudit produit emballé le plus bas (40) ; le distributeur automatique comprenant en outre une unité de commande configurée pour entraîner les unités de rétention (11) de la position de rétention à la position de distribution et pour ramener les unités de rétention (11) de la position de distribution à la position de rétention une fois qu'au moins ledit produit emballé le plus bas (40) de la pile est tombé sous l'effet de la gravité ; chaque unité de rétention (11) comprenant un corps de support (30), un élément mobile (31) et un actionneur de distribution (32) pour déplacer l'élément mobile (31) d'une position de rétention à une position de distribution et vice versa ;

caractérisé en ce que chaque élément mobile (31) est configuré pour passer de la position de rétention à la position de distribution en suivant un mouvement vers l'arrière le long d'une trajectoire linéaire, et pour passer de la position de distribution à la position de rétention en suivant un mouvement d'avance le long de la trajectoire linéaire.

2. Distributeur automatique, selon la revendication 1, **caractérisé en ce que** la trajectoire linéaire est perpendiculaire à l'axe longitudinal défini par la pile correspondante de produits emballés abaissés par gravité (40).
3. Distributeur automatique, selon la revendication 1 ou 2, **caractérisé en ce que** le corps de support (30) comprend une paroi frontale (35) pour guider l'au moins une partie de maintien de bord (41) du produit emballé (40).
4. Distributeur automatique, selon la revendication 3, **caractérisé en ce que** la paroi frontale (35) comprend au moins une ouverture (60) pour le passage d'au moins une partie de l'élément mobile (31).
5. Distributeur automatique, selon la revendication 4,

- caractérisé en ce que** la paroi frontale (35) comprend deux ou plusieurs ouvertures (60A, 60B, 60C, 60D) pour le passage de deux ou plusieurs parties (31A, 31B, 31C) de l'élément mobile correspondant (31).
6. Distributeur automatique, selon la revendication 5, **caractérisé en ce que** les ouvertures adjacentes (60A, 60B, 60C, 60D) sont séparées par une région intermédiaire (61), chaque région intermédiaire (61) interférant avec le mouvement d'avance de l'élément mobile (31) pour définir sa position de rétention.
7. Distributeur automatique, selon la revendication 6, **caractérisé en ce que** l'élément mobile (31) comprend un renforcement (39) pour chaque région intermédiaire (61), chaque renforcement ayant une surface distale (390) pour interférer avec la région intermédiaire correspondante (61), agissant comme une butée de l'élément mobile (31) et définissant la position de rétention de celui-ci.
8. Distributeur automatique, selon la revendication 7, **caractérisé en ce que** l'évidement (39) a deux surfaces latérales (391) s'étendant vers la surface distale (390) d'une manière convergente.
9. Distributeur automatique, selon l'une quelconque des revendications 6 à 8, **caractérisé en ce que** la région intermédiaire (61) fait partie de la paroi frontale (35).
10. Distributeur automatique, selon l'une quelconque des revendications précédentes, **caractérisé en ce que** l'élément mobile (31) comprend, à des extrémités longitudinales opposées de celui-ci, une protubérance (38) pour guider l'élément mobile (31) à travers l'ouverture correspondante (60, 60A, 60B, 60C, 60D).
11. Distributeur automatique, selon l'une quelconque des revendications précédentes, **caractérisé en ce qu'il** comprend en outre un mécanisme d'abaissement (70) pour recevoir le produit emballé distribué (40) et l'abaisser jusqu'à un élément de transport pour acheminer le produit emballé distribué (40) vers la zone de collecte (7), ou jusqu'à la zone de collecte (7).
12. Distributeur automatique, selon la revendication 11, **caractérisé en ce que** le mécanisme d'abaissement (70) comprend une plate-forme mobile (71) configurée pour s'élever dans une position de réception, dans laquelle elle reçoit le produit emballé distribué (40), et pour s'abaisser dans une position de déchargement, dans laquelle le produit emballé distribué (40) est déchargé vers l'élément de transport ou vers la zone de collecte (7).
13. Procédé de distribution d'un produit emballé (40) à partir d'un distributeur automatique comprenant les étapes suivantes :
- fournir un distributeur automatique selon l'une quelconque des revendications 1 à 12 ;
 - charger au moins un produit emballé (40) ayant des parties de maintien de bord opposées (41) sur une structure de stockage (15) pour stocker au moins une pile de produits emballés abaissés par gravité (40) de sorte que les parties de maintien de bord opposées (41) du produit emballé (40) reposent sur des éléments mobiles correspondants (31) d'unités de rétention (11) disposées dans une position de rétention ;
 - déplacer les éléments mobiles (31) des unités de rétention (11) de la position de rétention à une position de distribution, dans laquelle les parties de maintien des bord opposées (41) du produit emballé (40) ne reposent plus sur les unités de rétention (11), en suivant un mouvement vers l'arrière le long d'une trajectoire linéaire ;
 - laisser au moins le produit emballé le plus bas (40) tomber par gravité au-delà des éléments mobiles (31) des unités de rétention (11) ;
 - déplacer les éléments mobiles (31) des unités de rétention (11) de la position de distribution à la position de rétention en suivant un mouvement d'avance le long de la trajectoire linéaire ;
 - optionnellement, reposer les parties de maintien de bords opposées (41) du produit emballé le plus bas (40) suivant de la pile sur les unités de rétention (11) dans la position de rétention.
14. Procédé selon la revendication 13, comprenant en outre l'étape consistant à recevoir le produit emballé distribué (40) à l'aide d'un mécanisme d'abaissement (70) et à l'abaisser jusqu'à un élément de transport pour acheminer le produit emballé distribué (40) vers la zone de collecte (7), ou jusqu'à une zone de collecte (7).
15. Procédé, selon la revendication 14, dans lequel l'étape de réception du produit emballé distribué (40) et de son abaissement vers l'élément de transport ou vers la zone de collecte (7) comprend les étapes suivantes :
- élever une plate-forme mobile (71) jusqu'à une position de réception ;
 - recevoir le produit emballé distribué (40) sur la plate-forme mobile (71) ;
 - abaisser la plate-forme mobile (71) avec le produit emballé distribué (40) jusqu'à une position de déchargement ; et

- décharger le produit emballé distribué (40) vers l'élément de transport ou vers la zone de collecte (7).

5

10

15

20

25

30

35

40

45

50

55

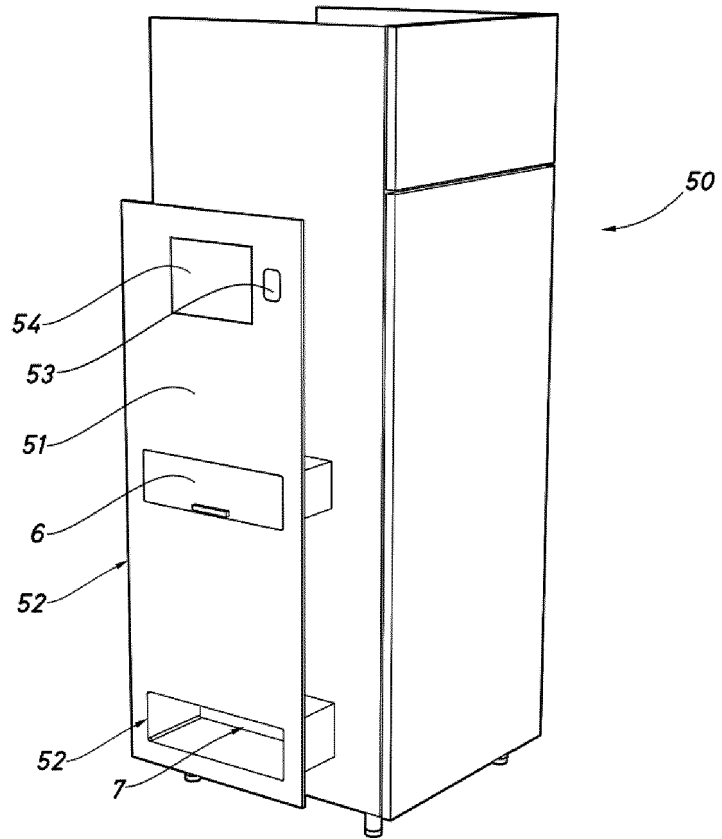

Fig.1

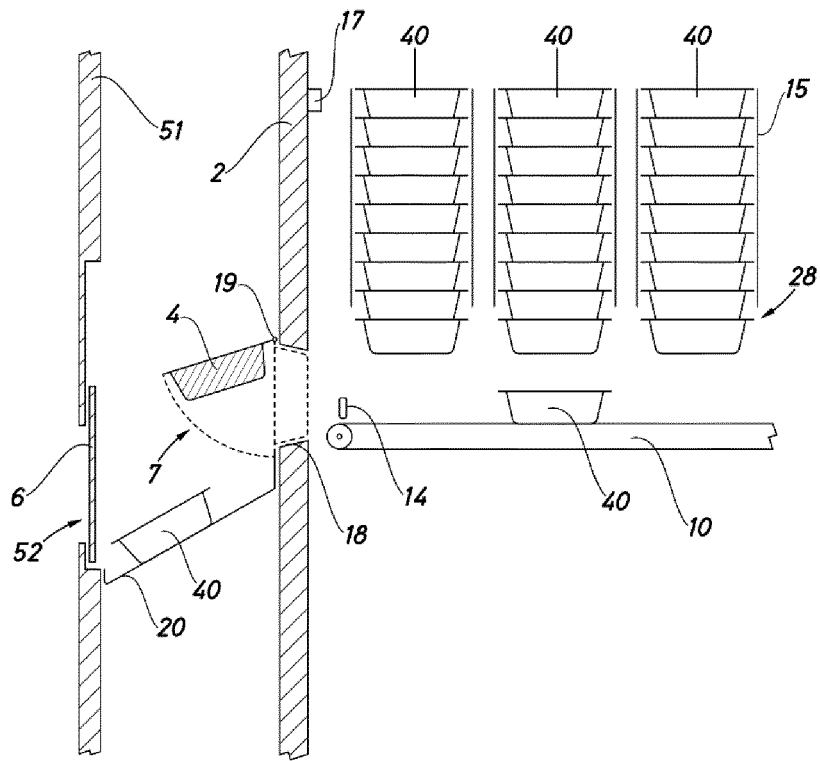

Fig.2

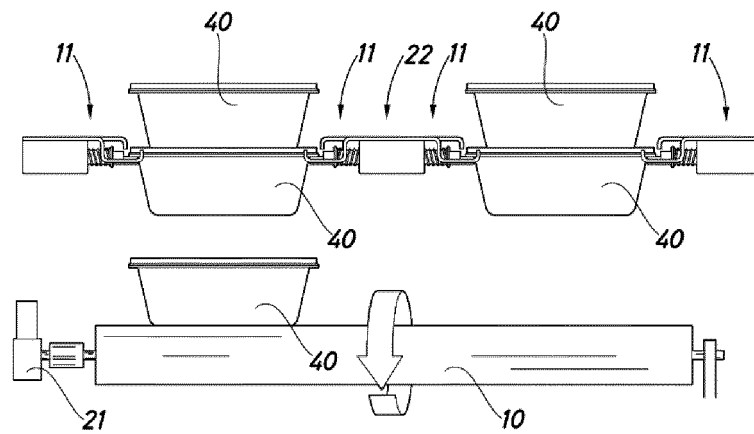

Fig.3

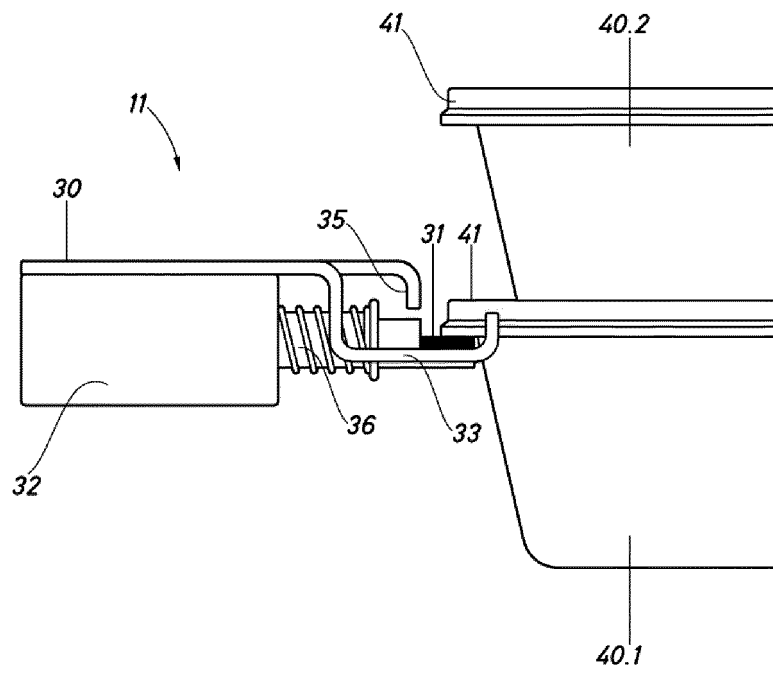

Fig.4

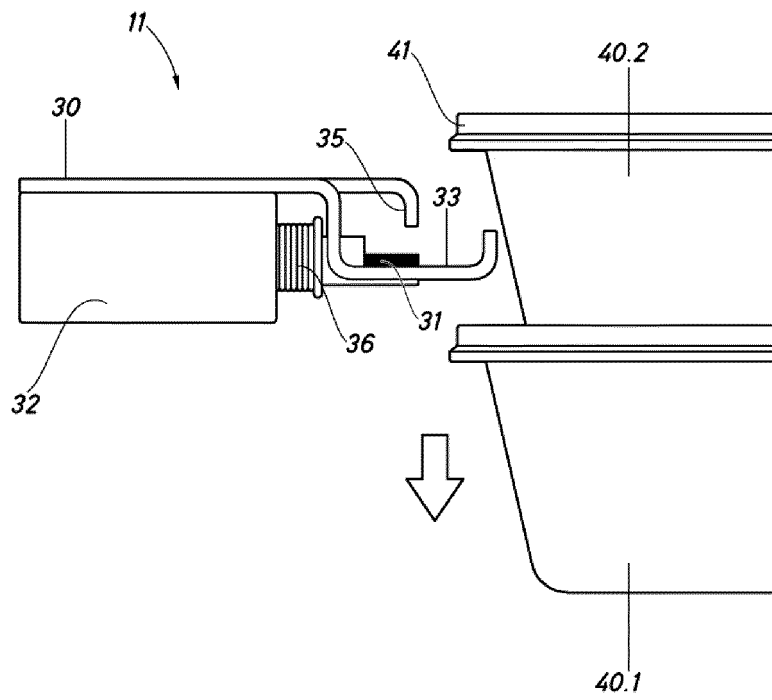

Fig.5

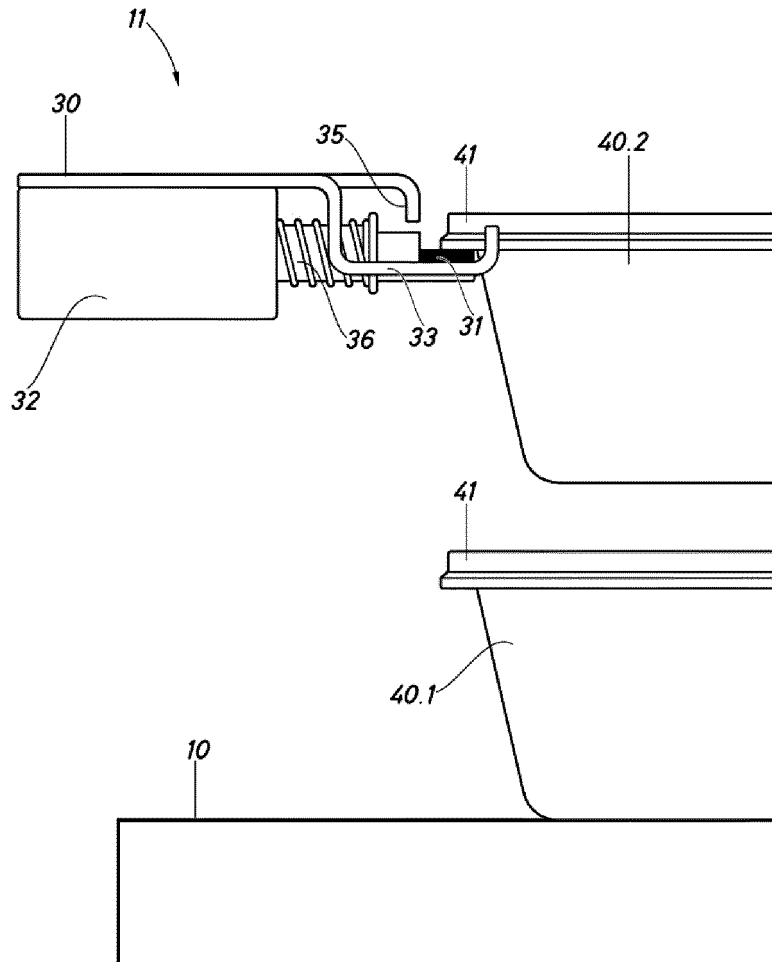

Fig.6

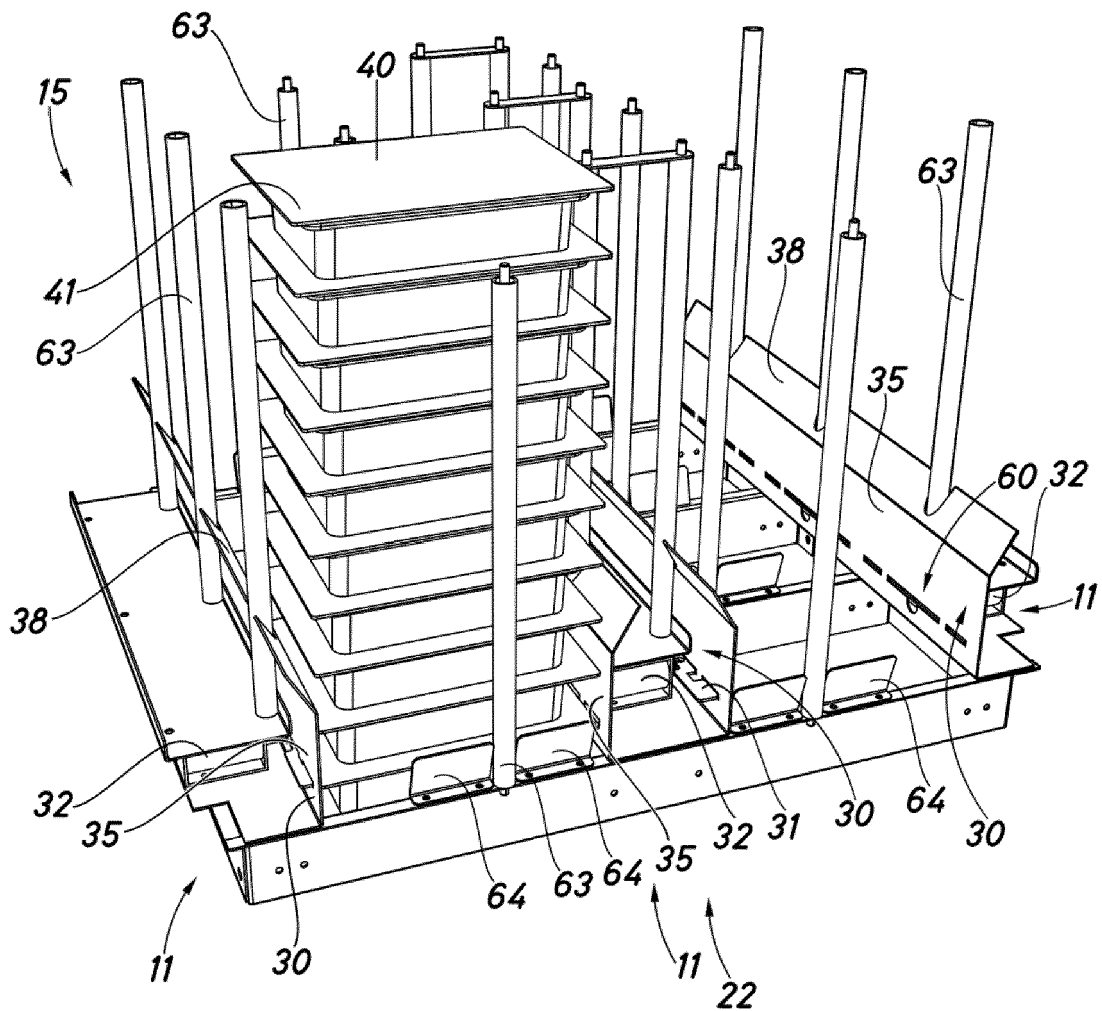

Fig.7

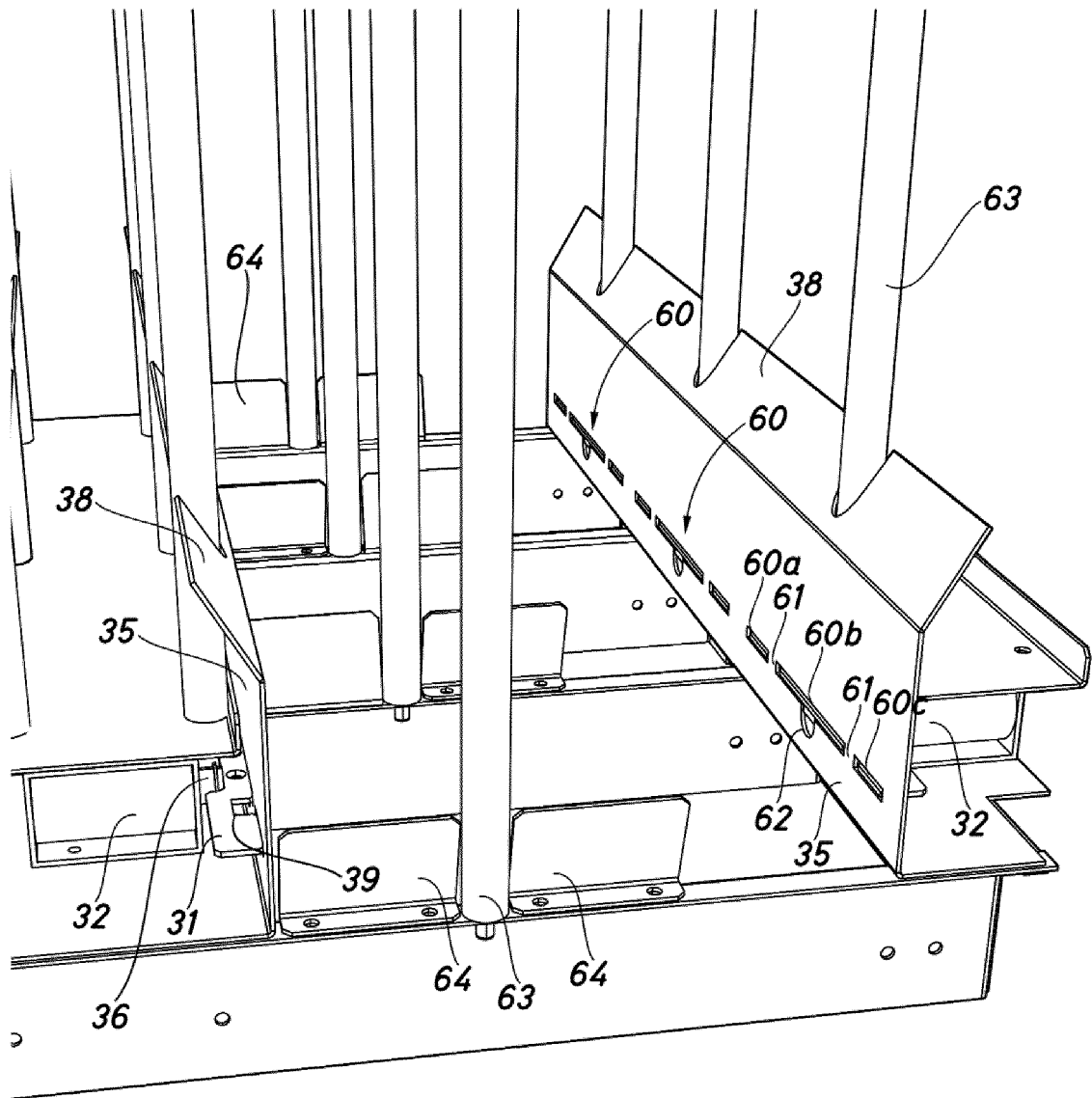

Fig.8

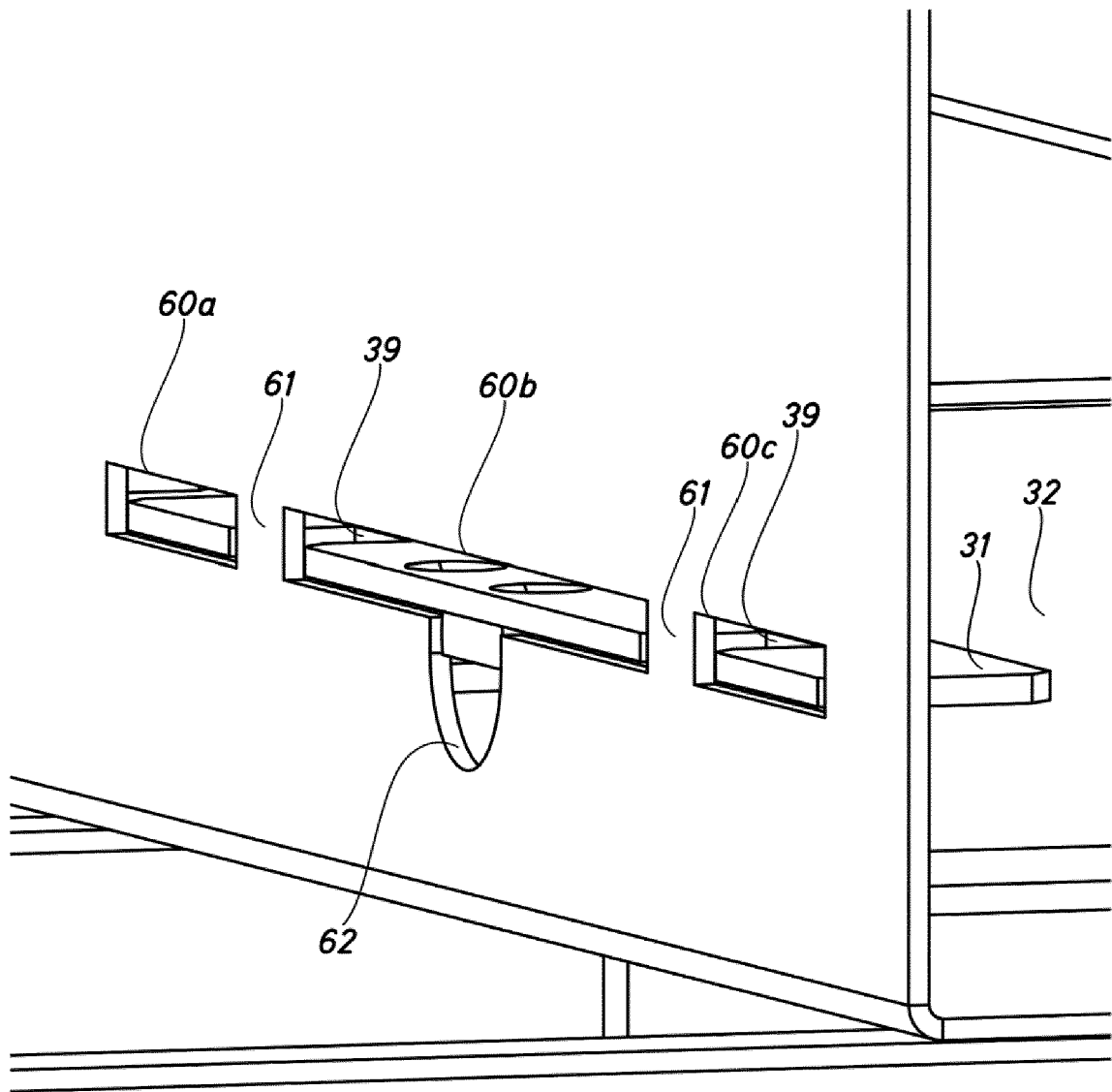

Fig.9

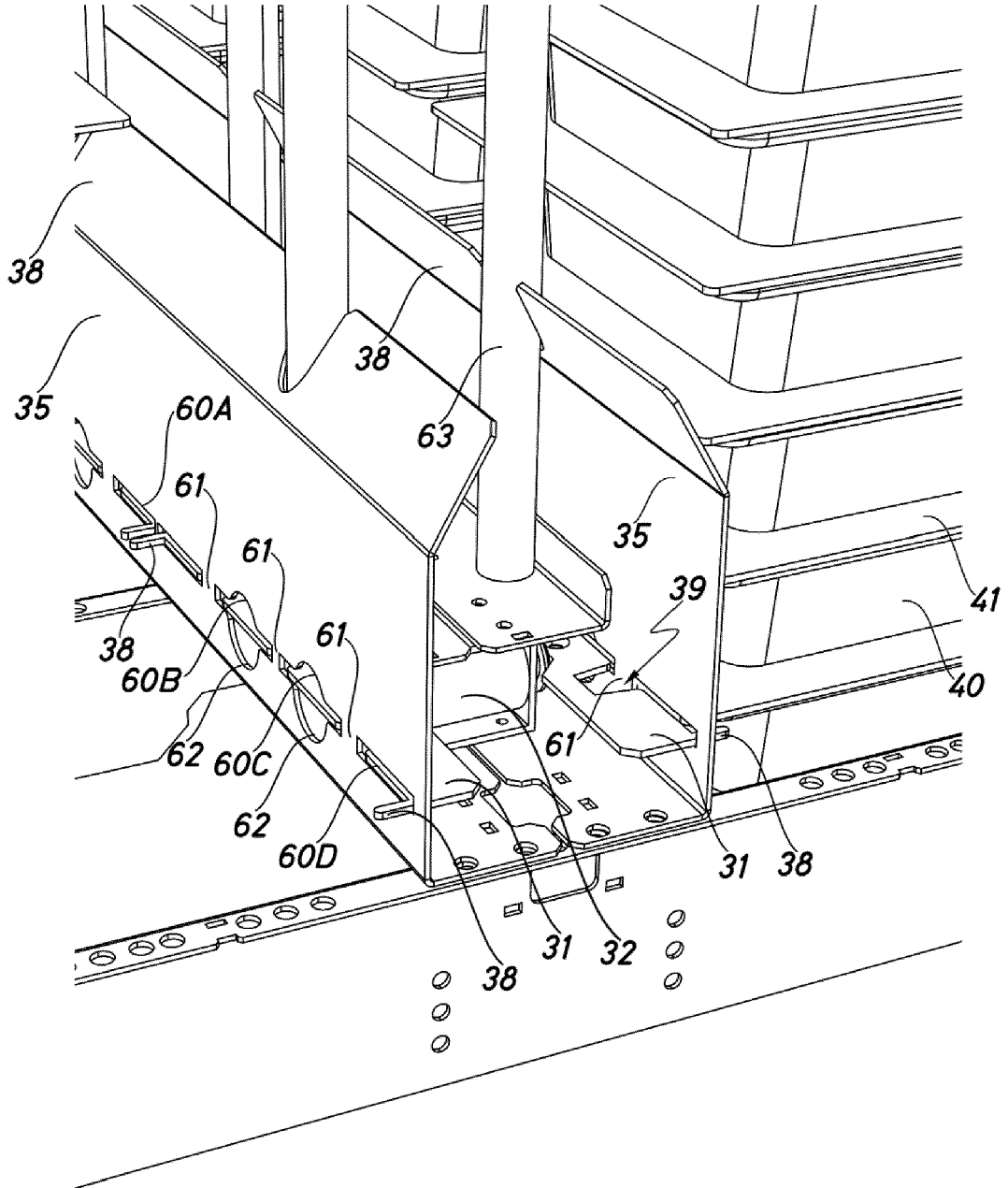

Fig.10

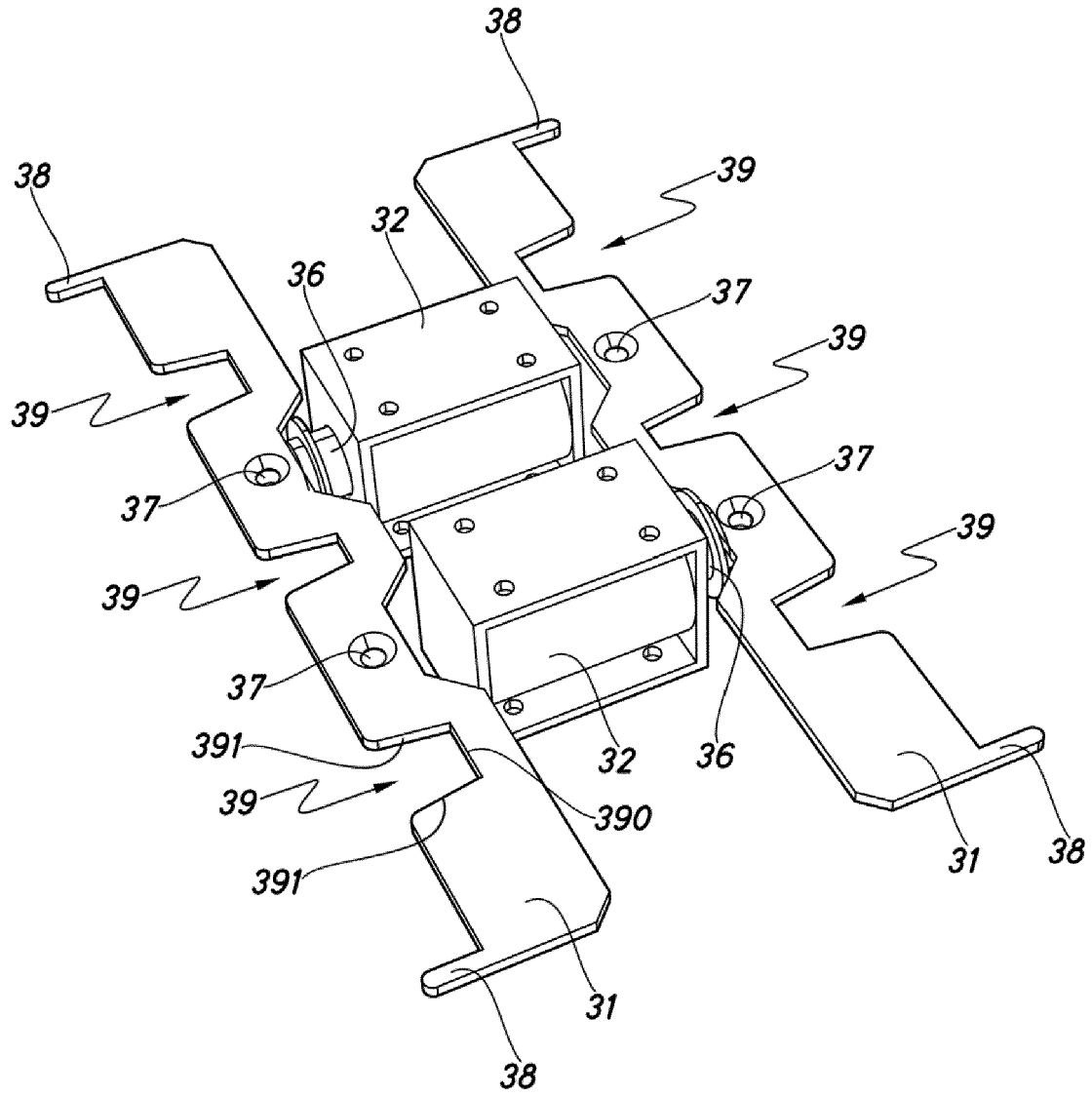

Fig.11

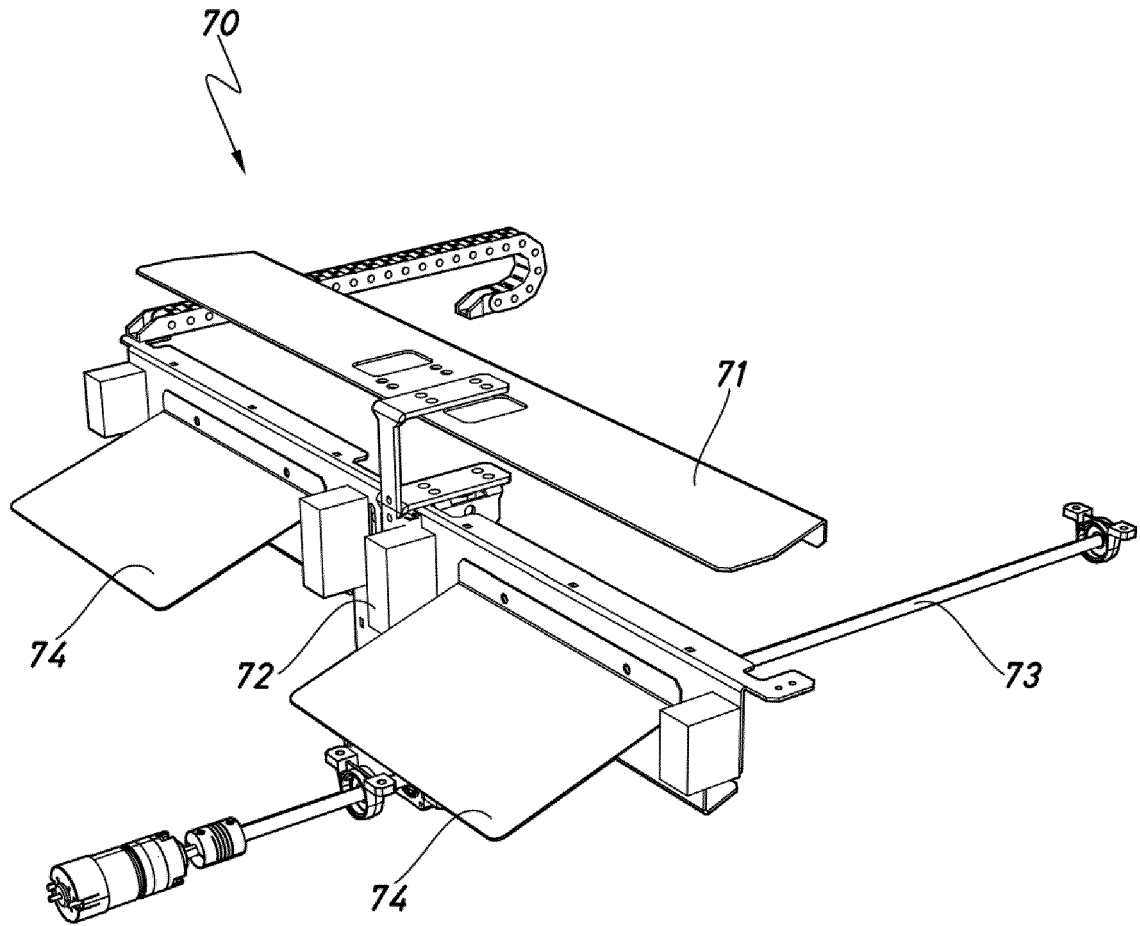

Fig.12

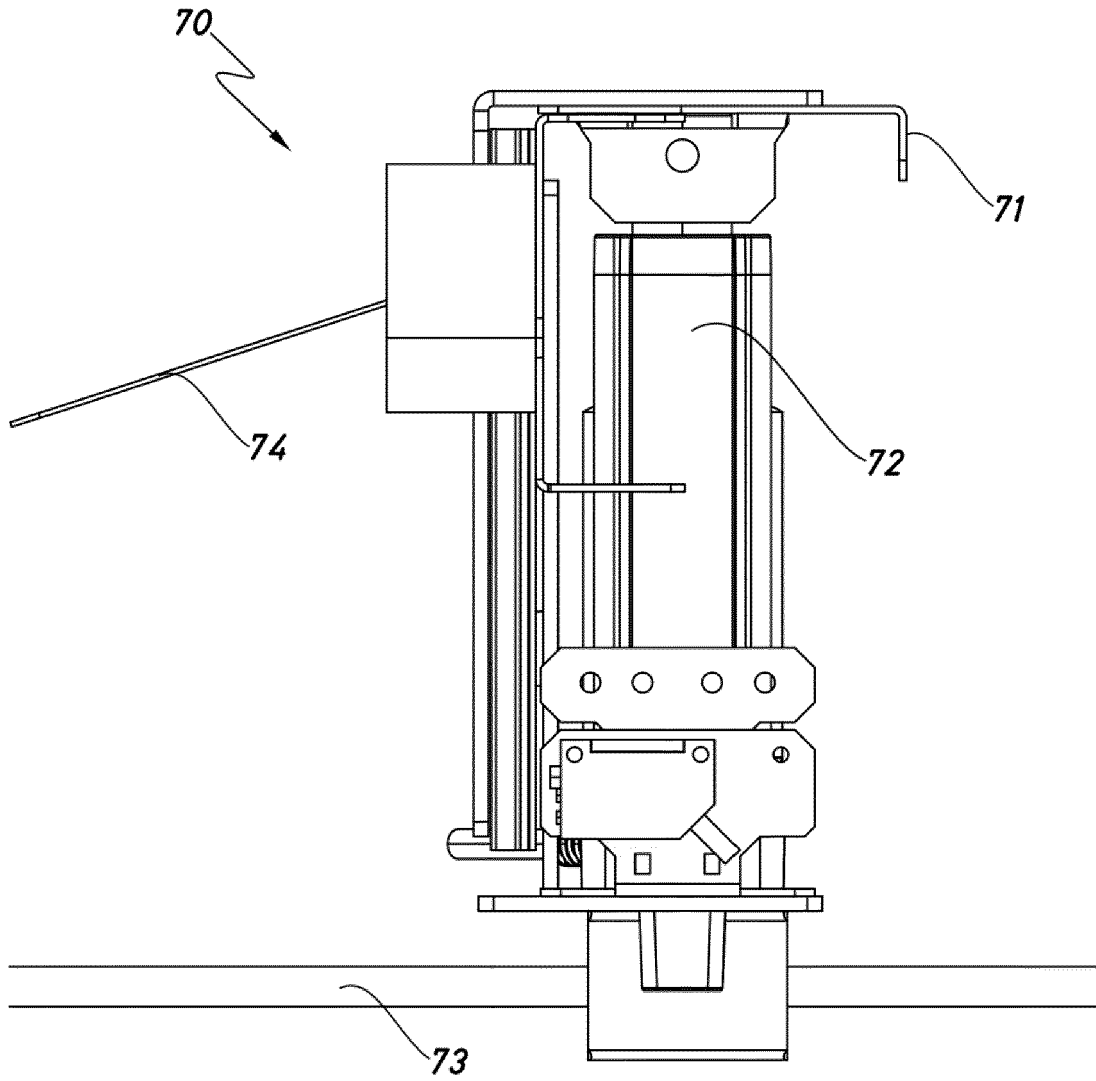

Fig.13

REFERENCES CITED IN THE DESCRIPTION

This list of references cited by the applicant is for the reader's convenience only. It does not form part of the European patent document. Even though great care has been taken in compiling the references, errors or omissions cannot be excluded and the EPO disclaims all liability in this regard.

Patent documents cited in the description

- WO 9428700 A2 [0007] [0008] [0009]
- US 3651752 A [0010]
- US 3137410 A [0011]
- US 3000538 A [0012]
- GB 2177075 A [0013]
- US 5285041 A [0014]
- WO 9739431 A1 [0015]