

F. B. Chapman,

Churn.

No. 111,907.

Patented Feb. 21. 1871.

Fig. 1.

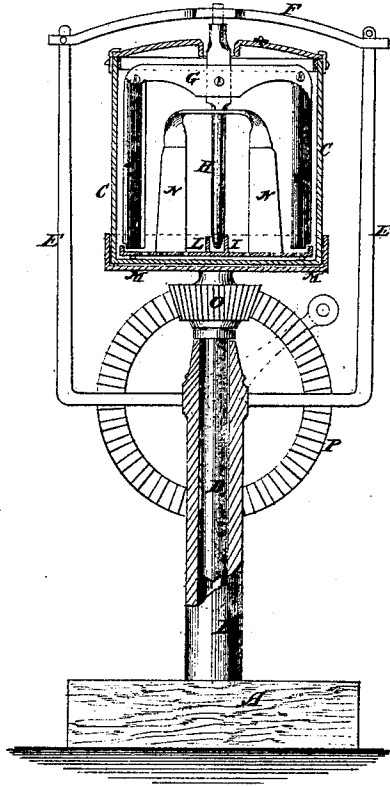
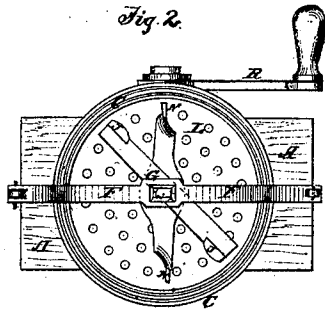

Fig. 2.



Witnesses:
L. S. Mabee
Alex. F. Roberts

Inventor:
F. B. Chapman
PER *Wm. C. Munn & Co.*
Attorneys.

UNITED STATES PATENT OFFICE.

FRANKLIN B. CHAPMAN, OF SALISBURY, MISSOURI.

IMPROVEMENT IN CHURNS.

Specification forming part of Letters Patent No. **111,907**, dated February 21, 1871.

To all whom it may concern:

Be it known that I, FRANKLIN B. CHAPMAN, of Salisbury, in the county of Chariton and State of Missouri, have invented a new and useful Improvement in Revolving Churn; and I do hereby declare that the following is a full, clear, and exact description thereof, which will enable others skilled in the art to make and use the same, reference being had to the accompanying drawing, forming part of this specification.

This invention relates to a new and useful improvement in a churn for converting cream and milk into butter; and consists in revolving the churn instead of the dasher, and in a revolving strainer and arms, and in stationary dasher within the churn, the whole arranged to operate as hereinafter more fully described.

In the accompanying drawing, Figure 1 represents a sectional elevation of the churn. Fig. 2 is a top view with the cover off.

Similar letters of reference indicate corresponding parts.

A is the base which supports the tubular column B. C is the barrel of the churn, to the bottom of which is rigidly attached the spindle D, which revolves in the hollow column B. E E are arms connected with the column B, as seen in Fig. 1, to the upper ends of which is attached, by pins or otherwise, so as to be readily revolved, the clamp F, for supporting the upper end of the stationary dasher-spindle H, the lower end of which is supported in a cup or step, I, as seen in Fig. 1. J J are two pendent wings of the dasher, which hang from the top piece to near the bottom of the barrel. These wings are broad,

and are placed in a slightly-oblique position. L is a perforated disk, which nearly fills the diameter of the barrel, and is made to revolve with the barrel by means of small lugs on the bottom of the barrel and on the under side of the disk, as seen at *m m*, Fig. 1. Attached to the top of this disk are two dashers, N N, connected together at the top and supported by the dasher-spindle H. O is a pinion on the spindle D, and P is a driving-wheel, which is revolved by the crank R on an arm which projects horizontally from the column B.

By this arrangement the churn is revolved by turning the crank, carrying with it the disk and the dashers N N, while the dasher G, with the pendent wings J J, remains stationary. By this means the cream or milk is thoroughly agitated, the globules of butter speedily broken, and the usually tedious operation of churning is performed in the most perfect and expeditious manner.

By raising the clamp the stationary dasher, as well as the disk and wings, or either of them, are readily removed for cleaning and other purposes.

Having thus described my invention, I claim as new and desire to secure by Letters Patent—

The combination, in a revolving churn, of the stationary dasher-wings J J and the disk L and revolving dashers N N, arranged and operating substantially as described.

FRANKLIN B. CHAPMAN.

Witnesses:

ANDREW W. TAYLOR,
ISAAC N. MOORHEAD.