

CANFIELD & HESS.

Wheel-Cultivator.

No. 53,408.

Patented Mar. 27, 1866.

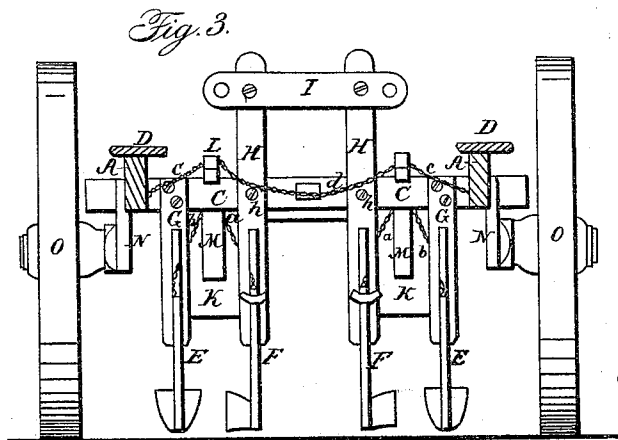
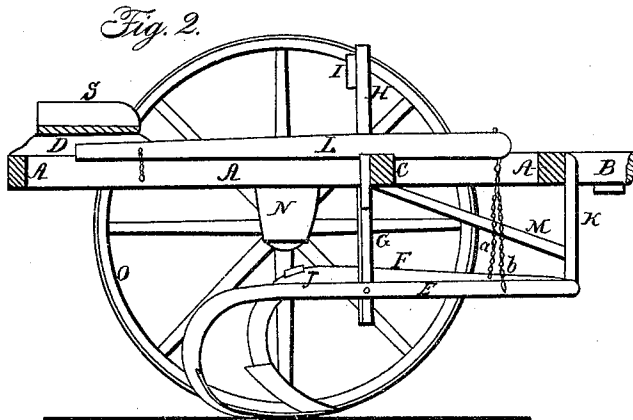
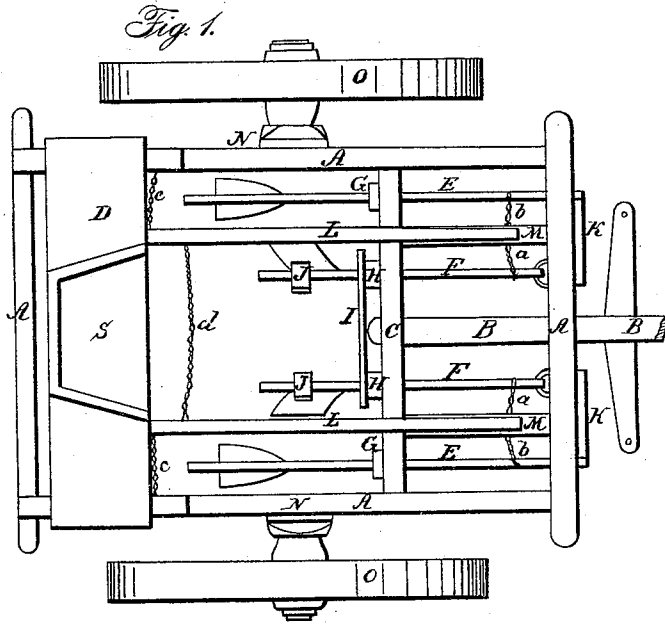

Witnesses:

S. W. Heintz
E. C. Hardy

Inventor:

James Canfield
Charles Hess.
by Coburn & Mans
Attorneys

UNITED STATES PATENT OFFICE.

JAMES CANFIELD, OF WASHINGTON, AND CHARLES HESS, OF LYONS, IOWA.

IMPROVEMENT IN CULTIVATORS.

Specification forming part of Letters Patent No. 53,408, dated March 27, 1866.

To all whom it may concern:

Be it known that we, JAMES CANFIELD, of Washington, in the county of Washington and State of Iowa, and CHARLES HESS, of Lyons, in the county of Clinton and State of Iowa, have invented a new and useful Improvement in Cultivators; and we do hereby declare that the following is a full, clear, and exact description of the same, reference being had to the accompanying drawings, and the letters and figures marked thereon, which form part of this specification.

Our invention relates to that class of cultivators which stride the rows and are supported upon wheels; and it consists in a novel arrangement whereby the plow-beams may be raised and lowered simultaneously, and the inner beams may be moved from side to side to conform to the crooks and irregularities in the rows when desired, and as hereinafter fully described.

To enable those skilled in the art to understand how to construct and use our invention, we will proceed to describe the same with particularity, making reference in so doing to the aforesaid drawings, in which—

Figure 1 represents a plan or top view of our invention; Fig. 2, a side sectional view at the line *x* in Fig. 1, and Fig. 3 a rear view of the same.

Similar letters of reference in the several figures indicate like parts of our invention.

A represents a rectangular frame, which is supported upon the wheels O O by means of suitable spindles attached to the lower ends of the uprights or attachments N N, as shown, B representing the tongue or draft-pole, which is rigidly secured to the front cross-bar, A, and the bar C.

D is a plank arranged across the rear of the machine to provide a seat, S, for the driver or operator.

E E represent the outer plow-beams, which are attached to the lower ends of the front uprights, K K, in such a manner that their rear ends have a free vertical motion; and F F represent the inner plow-beams, whose front ends are attached to the uprights K K in such a manner that their rear ends have both a vertical and a lateral motion.

The said beams E and F are respectively arranged in vertical slots in the hangers G H,

as shown, in which they may be adjusted at any position by pins beneath the beams passing through said hangers.

The hangers H H, in which the inner beams, F F, are arranged, and whose upper ends extend above the cross-bar C and are connected by the bar I, are pivoted to the said bar C at *h h*, so as to have a swinging motion from side to side, carrying with them the beams F F.

By means of the cross-bar I the hangers H H may be adjusted so as to make the inner plows run nearer to or farther from the row, as may be desirable, according to the size of the corn or the nature of the soil.

J J represent stirrups or foot-rests, upon which the driver may place his feet and so operate the inner plows thereby, moving them from side to side as the case may require.

L L represent levers, fulcrumed upon the cross-bar C, to whose front ends are connected the plow-beams E and F by means of the chains *a b*, as shown, so that the driver, by placing his feet upon the chain *d*, which connects the rear ends of said levers L L, may raise up all the plows from the ground simultaneously when turning around at the ends of the rows or moving from one field to another.

The chains *c c*, which extend from the rear end of the levers L to the side frame-pieces, as shown, are designed to be of such length as to allow the plows to run at any required depth in the soil, as the higher up the rear ends of the levers are allowed to move the deeper in the soil will the plows run, and hence the depth of the plows may be regulated and adjusted by taking up or letting out links in the chains *c c*.

By means of the pins in the hangers G and H, hereinbefore mentioned, the inner and outer plows may be adjusted so as to run at different depths, so that the outer plows may run deep and thoroughly stir the soil and uproot the weeds, while the inner plows may be adjusted so as not to cover the plants by running too deep.

The inner shovels, by changing places with each other, which is effected by changing the beams F from one side to the other, may be made to throw the earth toward the row instead of from it, if desired.

The uprights N N, to which the spindles for the wheels are attached, are adjustable upon

the frame in any suitable manner, so as to balance the machine or keep the equipoise with different drivers upon the seat.

Having described our invention, we will now specify what we claim and desire to secure by Letters Patent:

1. The combination and arrangement of the inner beams, F F, the slotted hangers H H, pivoted to the cross-bar C, and the regulating-bar I, operating as and for the purposes specified.

2. The combination and arrangement of the plow-beams E F, the hangers G H, the levers L L, cross-bar C, and chains *a b*, all arranged and operating as and for the purposes described.

JAMES CANFIELD.
CHARLES HESS.

Witnesses:

J. F. BROWN,
M. M. SHEARER,
W. E. FRASER.