

Aug. 4, 1936.

F. CARLSTEDT

2,049,602

VACUUM CLEANER

Filed Nov. 3, 1930

FIG. 1.

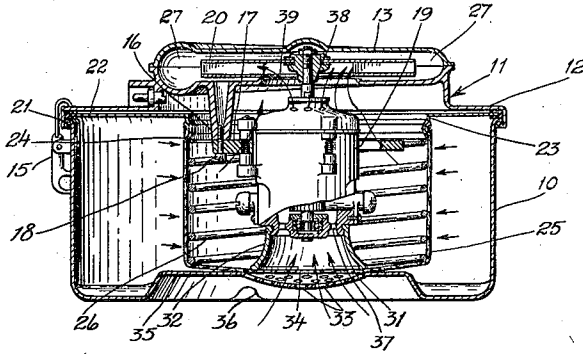
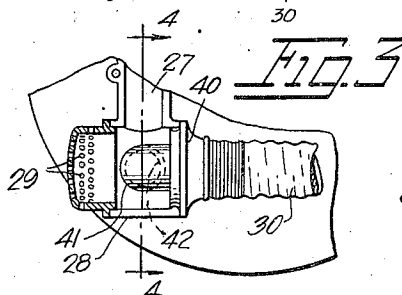
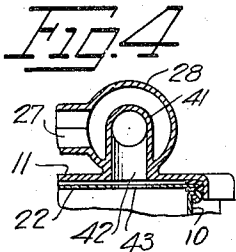
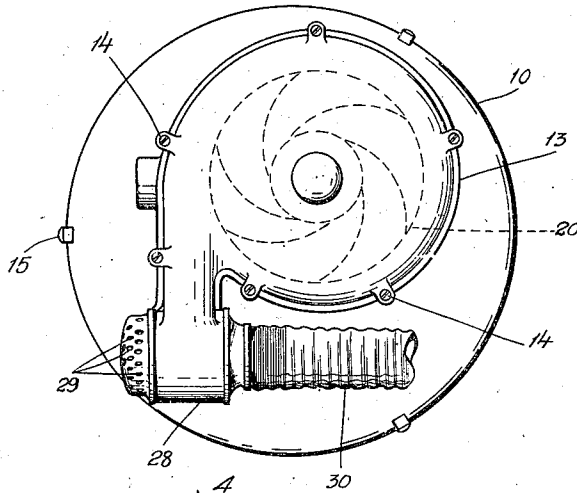

FIG. 2.



INVENTOR
Fredrik Carlstedt
BY
Wm. R. Hedlund
his ATTORNEY

UNITED STATES PATENT OFFICE

2,049,602

VACUUM CLEANER

Fredrik Carlstedt, Stockholm, Sweden, assignor,
by mesne assignments, to Electrolux Corpora-
tion, a corporation of Delaware

Application November 3, 1930, Serial No. 493,049
In Germany November 5, 1929

13 Claims. (Cl. 183—37)

This invention relates to vacuum cleaners and more particularly to new and improved means for the cooling of the motor. The invention is applicable to a vacuum cleaner in which the
5 motor is cooled by a separate air-stream, that is an air-stream which is independent of the air being sucked in through the normal suction opening of the cleaner.

An object of the invention is to provide a vacuum cleaner in which both air-streams are mixed and lead through one and the same fan.

Other objects of the invention are:

That both air-streams are mixed before entering the fan; to provide means for removing dust from the separate air-stream passing through the motor, and to provide a cheap, simple, convenient and efficient device for the purpose specified.

The invention also consists in certain new and original features of construction and combination of parts hereinafter set forth and claimed.

Although the novel features which are believed to be characteristic of this invention will be particularly pointed out in the claims appended hereto, the invention itself as to its objects and advantages, the mode of its operation and the manner of its organization may be better understood by referring to the following description taken in connection with the accompanying drawing forming part thereof, in which
25

Fig. 1 is a sectional view of a vacuum cleaner according to the invention;

Fig. 2 a plan view of the same cleaner;

Fig. 3 is a cross sectional view of a portion of the device shown in Fig. 2; and

35 Fig. 4 is a cross sectional view taken on the line 4—4 of Fig. 3.

In the figures, 10 denotes a casing of the cleaner and 11 a cover therefor. Cover 11 consists of two separable parts 12 and 13 which are held together
40 by means of screwbolts 14. Cover 11 is detachably secured to casing 10 by convenient means such as clips 15. From part 12 projections 16 extend into casing 10 forming a support for an annular member 17 suitably manufactured of any electrically insulating material. Member 17
45 which is secured to projections 16 by means of screw-bolts 18 serves as a support for the motor fan unit consisting of motor 19 and fan 20.

The manner in which the motor fan unit is supported has been fully described in U. S. patent application Serial No. 432,315, Patent No. 1,860,885, issued May 31, 1932, to T. E. D. Bilde.

Between the upper edge 21 of casing 10 and member 12 a plate or frame 22 is arranged, said
55 plate having an opening 23, and a flange 24 sur-

rounding said opening and extending into casing 10. To flange 24 a dust separating member or filter cell 25 is detachably connected, said member being kept in stretched position by means of a distending frame in the form of a spiral spring
5 26. The filter cell thus defines a space within which motor 19 is located and to which space dust and litter have no access. Fan 20 rotates in a housing formed of parts 12 and 13 which also form a volute shaped discharge channel 27. 10 Channel 27 opens into a valve casing 28, which is provided with outlet openings 29 and which is connected with a hose 30.

The interior construction of casing 28 is shown in Figs. 3 and 4. Hose 30 is secured to a 15 hollow member 40 forming part of the casing. To the inner end of member 40 is secured one end of an elbow 41. The other end of the elbow communicates with a passage 42 which extends through the lower part of the casing 28 to the interior of casing 10. Member 22 is provided with
20 an opening 43 in alignment with passage 42. Hence, communication is established from hose 30 through member 40, elbow 41, passage 42 and opening 43 to casing 10, and from channel 27
25 through casing 28 around the outside of elbow 41 to openings 29. Air is drawn in through hose 30 and, after passing through the cleaner, is discharged through openings 29.

The lower end of motor 19 is provided with 30 a flange 31 to which an annular funnel shaped member 32 is secured. Member 32 is suitably manufactured from any resilient and preferably electrically insulating material such as rubber or the like. Member 32 is further so dimen- 35 sioned with respect to motor 19 and casing 10 that in operative position it will press a part of the dust separating member 25 against the bottom of casing 10. That part of casing 10
40 which is surrounded by the lower edge of member 32 is provided with perforations 33, said part being bent slightly downwards. The part of member 25 surrounded by the lower edge of member 32 has been denoted with reference character 34. The bottom of casing 10 is bent
45 inwards as at 35 and is provided with a radially extending channel 36, to enable air to enter perforations 33 even if the cleaner rests on the floor or the like.

Motor 19 is at its lower end provided with 50 openings 37 and at its upper end with openings 38. Member 12 has an opening 39.

The operation of the vacuum cleaner now described is as follows:

As soon as motor 19 has been started, dust 55

laden air, due to the vacuum produced by fan 20 in the fan housing, will flow in through hose 30, member 40, elbow 41, passage 42 and opening 43, and into casing 10. From the casing 10 the air flows through member 25 where the dust is separated. The air then flows around motor 19, through openings 39 into the fan 20. The fan forces the air through the volute channel 27 and through casing 28 outside of elbow 41 and out through openings 29 to the atmosphere.

At the same time, however, air from the surrounding atmosphere will be drawn through openings 33, part 34 of the dust separating member, openings 37, through the different parts of motor 19, openings 38, opening 39 to fan 20 where it is mixed with the air being sucked in through hose 30 or the suction nozzle possibly connected therewith.

From the above it is evident that fresh cooling air always is passed through the motor not only when the suction nozzle is closed or nearly closed, and little or no air flows through hose 30 and the main part of dust separating member 25, but also when a large amount or maximum of air flows through said parts. The arrangement of parts 32, 34, 33, and 36 guarantees that only clean and filtered air is sucked through motor 19. A further advantage is that part 34 must be cleansed as often as the dust separating member 25 is removed for cleaning.

What I claim is:

1. A vacuum cleaner comprising a casing, means dividing said casing into a dust separation chamber, a fan chamber and a motor chamber, a fan member in said fan chamber, a motor in said motor chamber connected to rotate the fan member, and means providing a direct path from outside said casing for flow of air past said motor to cool the motor, said fan chamber having an inlet opening communicating with said dust chamber, and said path of flow being in direct communication with said inlet opening whereby air is drawn through said path of flow and through said inlet opening into said fan chamber.

2. A vacuum cleaner comprising a casing, means dividing said casing into a dust separation chamber, a fan chamber and a motor chamber, a fan in said fan chamber, a motor in said motor chamber connected to rotate said fan member, and means providing a direct path from outside said casing for flow of air past said motor to cool the motor, said fan chamber having a single inlet opening on one side thereof communicating with said dust chamber, and said path of flow being in direct communication with said inlet opening whereby air is drawn through said path of flow and through said inlet opening into said fan chamber, said inlet opening affording access of air to the entire blade surface of the fan.

3. A vacuum cleaner comprising a casing, means including an air filter dividing said casing into a dust separation chamber, a fan chamber and a motor chamber, a fan member in said fan chamber, a motor in said motor chamber connected to rotate said fan member, and means providing a direct path from outside said casing for flow of air past said motor to cool the motor, said air filter having a portion thereof extending across said path of flow, and said fan chamber having an inlet opening communicating with said dust chamber, and said path of flow being in direct communication with said inlet opening whereby air is drawn through said

path of flow and through said inlet opening into said fan chamber.

4. A vacuum cleaner comprising a casing having an air inlet, a fan in said casing, a motor in said casing below and connected to said fan, and a dust separating member surrounding said motor and providing a dust separation chamber outside said member and a motor chamber inside said member, said fan having a single inlet communicating with said motor chamber and supplying air to the entire blade surface of the fan.

5. A vacuum cleaner comprising a casing having an air inlet, a fan in said casing, a motor in said casing connected to said fan and including an apertured hood, a dust separating member surrounding said motor and providing a dust separation chamber outside said member and a motor chamber inside said member, and means cooperating with the motor hood and said casing to provide a path of flow for air through the motor hood, said fan having a single inlet communicating with said motor chamber to draw air in parallel from the dust separation chamber and the motor hood, and said fan inlet supplying air to the entire blade surface of the fan.

6. A vacuum cleaner comprising a casing having an air inlet, a fan in said casing, a motor in said casing connected to said fan and including an apertured hood, a dust separating member surrounding said motor and providing a dust separation chamber outside said member and a motor chamber inside said member, and a tubular member of electrical insulating material cooperating with the motor hood and said casing to provide a path of flow for air through the motor hood, said fan having a single inlet communicating with said motor chamber to draw air in parallel from the dust separation chamber and the motor casing, and said fan inlet supplying air to the entire blade surface of the fan.

7. A vacuum cleaner comprising a casing, a fan in said casing, a motor housing in said casing, a motor in said housing operatively connected to said fan, a dust separating member surrounding said motor housing and providing a dust separation chamber outside said member and a motor chamber inside said member, said casing having an air inlet communicating with said dust separation chamber, and means for conducting air from outside said casing to within said motor housing, said fan having a single inlet communicating with said motor chamber and supplying air to the entire blade surface of the fan, said motor housing being formed with apertures for the flow of air from within said housing to within said motor chamber.

8. In an electric vacuum cleaner, in combination, a receptacle, a cover carried thereby, a pump carried by said cover, a motor suspended below said cover inside said receptacle and operatively connected to said pump in spaced relation, a dust separating member around said motor and spaced from the walls of said receptacle to define a litter-chamber, the interior of said dust separating member defining a chamber about said motor to which litter has no access, an inlet fitting carried by said cover and communicating with said litter-chamber outside of said dust separating member, and a conduit leading from the pump outlet to the outer air, the pump inlet being presented to said motor and communicating with the space inside said dust separating member.

9. A pneumatic cleaner comprising, in combination, a hollow casing having stiff walls and a

cover, a filter cell supported within said casing and spaced from the casing walls to define a litter-chamber, a motor in said cell, a pump spaced from and driven by said motor and having its inlet communicating with the interior of said filter-cell and its outlet through said cover, said motor being located opposite to the inlet of said pump, and a suction-connection carried by said cover communicating with the space inside said casing and outside said filter-cell.

10 10. A pneumatic cleaner comprising, in combination, a hollow casing having stiff walls, a pump carried by one wall having an inlet inside said casing and an outlet outside said casing, a motor in said casing spaced from and operatively connected to said pump, said inlet being located between said pump and said motor, a filter-cell inside said casing surrounding said motor and communicating with said inlet, said filter-cell defining a chamber about said motor to which litter has no access, a hose connection communicating with the space between said filter-cell and the casing wall, and a distending frame inside said filter-cell.

25 11. A pneumatic cleaner comprising, in combination, a hollow casing having stiff walls, a frame carried by one of said walls and projecting into the casing, filtering material carried by said frame and separating the space inside the same from the rest of the casing, the space outside of said filter constituting a litter-chamber, an electric motor located inside said filter, a pump operatively connected to said motor in spaced relation and having its inlet presented to said motor in free communication with the space inside said filter and its outlet discharging outside

of said casing, and a hose-connection carried by a part of said casing and communicating with said litter-chamber.

5 12. A pneumatic cleaner comprising, in combination, an upright dust receptacle having imperforate walls, a removable cover for said receptacle, means detachably securing said cover to said receptacle, a suction pump carried by said cover and having an inlet and an outlet, an electric motor operatively connected to said pump in spaced relation in front of the inlet opening thereof, a filtering element of pervious material carried by said receptacle and depending into said receptacle and spaced from the walls thereof, the inner wall of said filtering element defining a suction chamber and communicating with said inlet, and the exterior thereof defining with said receptacle a litter chamber, and a hose connection carried by said cover and communicating with said litter-chamber.

10 13. In a vacuum cleaner, a casing formed with a dust laden air inlet and a clean air outlet, a dust separating member in said casing having a portion disposed between said inlet and said outlet, a motor, means providing a path of flow of air independently of said dust laden air inlet from the atmosphere past said motor, another portion of said dust separating member being disposed across said path of flow between the atmosphere and said motor, and means driven by said motor for producing flow of air through said dust laden air inlet, said dust separating member and said outlet, and for producing an independent flow of air through said path of flow.

35 FREDRIK CARLSTEDT.