

(19)



(11)

EP 3 441 320 B1

(12)

EUROPEAN PATENT SPECIFICATION

(45) Date of publication and mention of the grant of the patent:

16.03.2022 Bulletin 2022/11

(51) International Patent Classification (IPC):

B65D 39/00 ^(2006.01) **B65D 39/16** ^(2006.01)

(21) Application number: **17185393.0**

(52) Cooperative Patent Classification (CPC):

B65D 39/0052; B65D 39/16; B65D 2203/12; B65D 2539/003; B65D 2539/006

(22) Date of filing: **08.08.2017**

(54) **LUMINOUS BOTTLE STOPPER**

LEUCHTENDE FLASCHENSTOPFEN

BOUCHON DE BOUTEILLE LUMINEUX

(84) Designated Contracting States:

AL AT BE BG CH CY CZ DE DK EE ES FI FR GB GR HR HU IE IS IT LI LT LU LV MC MK MT NL NO PL PT RO RS SE SI SK SM TR

• **KUO, Yu-Feng**

24450 Linkou 2nd Industrial Park, Linkou Dist. New Taipei City (TW)

(43) Date of publication of application:

13.02.2019 Bulletin 2019/07

(74) Representative: **2K Patentanwälte Blasberg**

Kewitz & Reichel Partnerschaft mbB Schumannstrasse 27 60325 Frankfurt am Main (DE)

(73) Proprietor: **San Ho Enterprise Co., Ltd.**

New Taipei 24450 (TW)

(72) Inventors:

- **KUO, Chia-Shin**
24450 Linkou 2nd Industrial Park, Linkou Dist. New Taipei City (TW)

(56) References cited:

WO-A1-2014/196484 DE-U1-202008 001 443
FR-A1- 3 008 961 GB-A- 2 464 524
US-A1- 2015 217 912

EP 3 441 320 B1

Note: Within nine months of the publication of the mention of the grant of the European patent in the European Patent Bulletin, any person may give notice to the European Patent Office of opposition to that patent, in accordance with the Implementing Regulations. Notice of opposition shall not be deemed to have been filed until the opposition fee has been paid. (Art. 99(1) European Patent Convention).

Description

Field of the Invention

[0001] The present invention generally relates to a bottle stopper and, in particular to a luminous bottle stopper.

Description of Prior Art

[0002] There are a lot of wine bottles provided with bottle stoppers. As wines are usually not one-time drinking, so bottle stoppers can be used to seal the mouth of bottle when some wine are still left in the bottle. Thus external air can be prevented from entering the bottle, and a long-term reserve of wine can be achieved.

[0003] US 2015217912 A1 discloses a preservation apparatus and method for using the same are disclosed herein. In one embodiment, the preservation apparatus comprising: a removable closure adapted to fit together in sealed relationship with a first container for containing an item, where the removable closure comprises a second container to contain a substance operable to collect oxygen molecules contained within the first container. The preservation apparatus also comprises a removable cap adapted to cover a portion of the removable closure including the second container, in order prevent the second container from being exposed to oxygen molecules outside the cap.

[0004] DE 20 2008 001443 discloses an illuminated bottle stopper.

[0005] Furthermore, the designs of the bottle stoppers can not only seal the mouth of bottle but also enhance the design sense and overall appearance as to attract consumers for increasing purchase intention if the designs of the bottle stoppers are corresponded with the bottles. Thus, how to design a new bottle stopper with additional features such as to enhance the identification or the overall appearance is the research motivation of the present invention.

[0006] In view of the above drawbacks, the Inventor proposes the present invention based on his expert knowledge and elaborate researches in order to solve the problems of prior art.

[0007] Accordingly, an object of the present invention is to provide a luminous bottle stopper as to enhance the effects of identification and overall appearance.

[0008] In order to achieve the object mentioned above, the present invention provides a luminous bottle stopper to be plugged in a mouth of bottle comprising a light guide body, a light emitting module, a power module, a stopper cover and a flexible sleeve. The light guide body is made of light transmitting material and includes a light guide seat and a light guide column, and the light guide seat has an accommodating space. The light emitting module is installed in the accommodating space and includes a circuit board and a light emitting element electrically connected with the circuit board. The power module is installed in the accommodating space and includes at least

one battery and a conduct element electrically connected with the at least one battery. The conduct element is electrically connected with the circuit board. The stopper cover is combined with the light guide seat and sealed the accommodating space. The flexible sleeve is made of light transmitting material and sleeved on the light guide column and is able to be plugged in the mouth of bottle. Thereby the identification and the overall appearance can be enhanced.

[0009] Comparing to the prior art, the bottle stopper of the present invention includes a light guide body, a light emitting module, a power module, a stopper cover and a flexible sleeve. The light guide body includes a light guide seat and a light guide column. The light emitting module and the power module are disposed in the light guide seat. In addition, the light guide body and the flexible sleeve are made of light transmitting material; therefore, the light emitted from the light emitting element will be transmitted to the light guide seat and the light guide column and then transmitted to the outside through the light guide seat. On the other hand, the light emitted to the light guide column will pass through the flexible sleeve and the mouth of the bottle so that the luminous bottle stopper and areas surrounding the mouth of the bottle both have lighting effects as to enhance the identification, creativity and uniqueness of the overall appearance.

BRIEF DESCRIPTION OF DRAWING

[0010] The features of the invention believed to be novel are set forth with particularity in the appended claims. The invention itself, however, may be best understood by reference to the following detailed description of the invention, which describes a number of exemplary embodiments of the invention, taken in conjunction with the accompanying drawings, in which:

FIG. 1 is a perspective schematic view in one side of the luminous bottle stopper of the present invention;

FIG. 2 is a perspective schematic view in another side of the luminous bottle stopper of the present invention;

FIG. 3 is a perspective explosion schematic view of the luminous bottle stopper of the present invention; FIG. 4 is a perspective explosion schematic view of the light emitting module and the power module of the present invention;

FIG. 5 is a cross sectional view of the luminous bottle stopper of the present invention;

FIG. 6 is a lighting schematic view of the luminous bottle stopper of the present invention.

DETAILED DESCRIPTION OF THE PREFERRED EMBODIMENTS

[0011] In cooperation with attached drawings, the technical contents and detailed description of the invention

are described hereinafter according to a number of preferable embodiments, being not used to limit its executing scope. Any equivalent variation and modification made according to appended claims is all covered by the claims claimed by the present invention.

[0012] Please refer to FIG. 1 and FIG. 2, which depict perspective schematic views of two sides of the luminous bottle stopper. The present invention provides a luminous bottle stopper 1 including a light guide body 10, a light emitting module 20, a power module 30, a stopper cover 40 and a flexible sleeve 50. The light emitting module 20 and the power module 30 are disposed in the light guide body 10. The stopper cover 40 and the flexible sleeve 50 are combined on two sides of the light guide body 10 separately as to constitute the luminous bottle stopper 1. More details of the luminous bottle stopper 1 are described as follows.

[0013] Please further refer to FIG. 3 and FIG. 4, which depict an explosion schematic view of the luminous bottle stopper of the present invention and an explosion schematic view of the light emitting module and the power module of the present invention. In an embodiment of the present invention, the light guide body 10 is made of light transmitting material. The light guide body 10 includes a light guide seat 11 and a light guide column 12 connected with the light guide seat 11, and the light guide seat 11 has an accommodating space 110.

[0014] Preferably, the light guide seat 11 and the light guide column 12 are formed as an integral body. Besides, an outer peripheral surface of the light guide column 12 has formed a light guide rib 121 shaped in helical. The arrangement of the light guide rib 121 can facilitate a uniform and soft light conducting for a better luminous efficiency. Furthermore, the light guide column 12 also has textures, printed veins or carved light guide lines 120 as to enhance the lighting effects.

[0015] In the present embodiment, the light guide seat 11 has a light guide angle 113 neighboring a side of the light guide column 12, and the deposition of the light guide angle 113 can transmit the light emitted from the light emitting module 20 to the light guide column 12. It is worthy of notice that an inner wall of the light guide seat 11 has further provided with a reflecting layer 114, and the deposition of the reflecting layer 114 can increase the luminous efficiency.

[0016] The light emitting module 20 is installed in the accommodating space 110 of the light guide seat 11. The light emitting module 20 includes a circuit board 21 and a light emitting element 22 electrically connected with the circuit board 21. In the present embodiment, the light emitting element 22 is, but not limited to, a light emitting diode (LED).

[0017] The power module 30 is installed in the accommodating space 110 of the light guide seat 11 and located in a lateral side of the light emitting module 20. The power module 30 is the power source of the light emitting module 20 including at least one battery 31 and a conduct element 32 electrically connected with the at least one

battery 31, and the conduct element 32 is electrically connected with the circuit board 21. Thus, the battery 31 can be electrically to the light emitting element 22 through the circuit board 21 and provide power to the light emitting element 22 for the lighting. In the present embodiment, the conduct element 32 is a conductive sheet, however, in real practice, the conduct element 32 can be a wire and so on.

[0018] It is to be noted that the battery 31 may be provided as a dry battery, a lithium battery, a button battery, or a rechargeable battery. In addition, the power module 30 can further include a touch switch. The touch switch is electrically connected with the circuit board 21 and can be disposed in the stopper cover 40 for controlling the light emitting element 22,

[0019] The stopper cover 40 is coupled to the light guide seat 11 and sealed the accommodating space 110.

[0020] Moreover, the flexible sleeve 50 is made of light transmitting material and sleeved on the light guide column 12. In an embodiment of the present invention, the flexible sleeve 50 comprises a holding portion 51 and a revolving fasten portion 52. The holding portion 51 is abutted upon a bottom of the light guide seat 11, and an outer peripheral surface of the revolving fasten portion 52 has formed a seal rib 521 shaped in a helical.

[0021] Specifically, an outer peripheral surface of the light guide column 12 of the light guide body 10 has formed a light guide rib 121. Moreover, the flexible sleeve 50 has formed a light guide slot 501 shaped in helical corresponding to the light guide rib 121, and the light guide rib 121 of the light guide column 12 is located in the light guide slot 501.

[0022] In an embodiment of the present invention, the luminous bottle stopper 1 further includes a seal ring 60 disposed between the light guide seat 11 and the stopper cover 40 as to enhance the leak tightness therebetween. Furthermore, the light guide seat 11 has formed an annular groove 111 in the accommodating space 110, and the stopper cover 40 has a pressing plate 401 disposed correspondingly above the annular groove 111. Accordingly, the seal ring 60 is disposed in the annular groove 111 and pressed by the pressing plate 401; thereby, external air or moisture can be prevented from entering the accommodating space 110.

[0023] Preferably, an inner wall of the light guide seat 11 are formed a plurality of resist ribs 112 at a bottom of the annular groove 111, and the resist ribs 112 are tightly attached to the periphery of the stopper cover 40 as to fix the stopper cover 40 on the light guide seat 11. In the present embodiment, the stopper cover 40 includes a cover plate 41 and a plurality of support plate 42 connected with the cover plate 41, and the resist ribs 112 abut against an outer side of the support plate 42. Furthermore, the cover plate 41 has a notch 410, and the cover plate 41 has formed a positioning portion 411 in the notch 410 (in the present embodiment, a positioning groove is configured by a pair of ribs). Thereby, the luminous bottle stopper 1 of the present invention is mov-

able by exerting on the positioning portion 411 and rotating it.

[0024] It is to be noted that, in the present embodiment, the light emitting module 20 further includes a bearing seat 23. The bearing seat 23 carries the circuit board 21 and has a through hole 230 corresponding to the light emitting element 22. Moreover, one part of the light emitting element 22 is located in the through hole 230 and another part thereof is located in the light guide seat 11.

[0025] Please refer to FIG. 5 and FIG. 6, they depict a cross sectional view of the assembly of the luminous bottle stopper of the present invention and a lighting schematic view of the luminous bottle stopper of the present invention. As shown in FIG. 5, after assembling of the luminous bottle stopper 1 of the present invention, the air tightness between the stopper cover 40 and the light guide body 10 can be achieved through the seal ring 60 so that the light emitting module 20 and the power module 30 inside the light guide seat 11 will have good electricity characteristics. Furthermore, one part of the light emitting element 22 is located in the light guide seat 11, hence the light emitted from the light emitting element 22 will be transmitted to the light guide seat 11 and the light guide column 12, and then the light will be transmitted to outside through the light guide seat 11 and the light guide column 12.

[0026] Please refer to FIG. 6, the luminous bottle stopper 1 is used to be plugged in a mouth 2 of a bottle. As shown in the figure, the flexible sleeve 50 of the luminous bottle stopper 1 is sleeved on the light guide column 12 and can be plugged in the mouth 2 of the bottle. Furthermore, the light guide body 10 and the flexible sleeve 50 are made of light transmitting material. Thus the light emitted from the light emitting element 22 will be transmitted to the light guide seat 11 and the light guide column 12, and then the light will be transmitted to the outside through the light guide seat 11 and the light guide column 12. On the other side, the light emitted to the light guide column 12 will pass through the flexible sleeve 50 and the mouth 2 of the bottle so that the luminous bottle stopper 1 and areas surrounding the mouth 2 of the bottle both have lighting effects. Besides, the light guide ribs 121 of the light guide column 12 can facilitate a uniform and soft light conducting for a better luminous efficiency and enhance the overall appearance, creativity and uniqueness of the present invention.

Claims

1. A luminous bottle stopper to be plugged in a mouth (2) of a bottle, comprising:

a light guide body (10) made of light transmitting material, the light guide body (10) including a light guide seat (11) and a light guide column (12) connecting with the light guide seat (11), and the light guide seat (11) having an accom-

modating space (110);

a light emitting module (20) installed in the accommodating space (110), the light emitting module (20) including a circuit board (21) and a light emitting element (22) electrically connected with the circuit board (21);

a power module (30) installed in the accommodating space (110), the power module (30) including at least one battery (31) and a conduct element (32) electrically connected with the at least one battery (31);

a stopper cover (40) combined with the light guide seat (11) and sealed the accommodating space (110); and

a flexible sleeve (50) made of light transmitting material, the flexible sleeve (50) being sleeved on the light guide column (12) and able to be plugged in the mouth (2) of the bottle, **characterized in that** an outer peripheral surface of the light guide column (12) is formed with a light guide rib (121) shaped in helical.

2. The luminous bottle stopper according to claim 1, wherein an outer peripheral surface of the light guide column (12) has textures, printed veins or carved light guide lines (120).
3. The luminous bottle stopper according to any of the claims 1 to 2, further including a seal ring (60), in which the seal ring (60) is disposed between the light guide seat (11) and the stopper cover (40); the light guide seat (11) is formed an annular groove (111) in the accommodating space (110), and the stopper cover (40) has a pressing plate (401) disposed correspondingly above the annular groove (111); the seal ring (60) is disposed in the annular groove (111) and pressed by the pressing plate (401).
4. The luminous bottle stopper according to any of the claims 1 to 3, wherein the light guide seat (11) has a light guide angle (113) neighboring a side of the light guide column (12); an inner wall of the light guide seat (11) is further provided with a reflecting layer (114).
5. The luminous bottle stopper according to claim 3 or 4, wherein an inner wall of the light guide seat (11) is formed a plurality of resist ribs (112) at a bottom of the annular groove (111), and the resist ribs (112) are tightly attached to the stopper cover (40); the stopper cover (40) includes a cover plate (41) and a plurality of support plate (42) connected with the cover plate (41), and the resist ribs (112) abut against an outer side of the support plate (42).
6. The luminous bottle stopper according to claim 5, wherein the cover plate (41) has a notch (410), and the cover plate (41) is formed a positioning portion

(411) in the notch (410); the luminous bottle stopper (1) is movably relative to the mouth (2) of the bottle by exerting on the positioning portion (411).

7. The luminous bottle stopper according to any of the claims 1 to 6, wherein the light emitting module (20) further includes a bearing seat (23), and the bearing seat (23) carries the circuit board (21) and has a through hole (230) corresponding to the light emitting element (22); one part of the light emitting element (22) is located in the through hole (230) and another part thereof is located in the light guide seat (11).
8. The luminous bottle stopper according to any of the claims 1 to 7, wherein the flexible sleeve (50) includes a holding portion (51) and a revolving fasten portion (52); the holding portion (51) is abutted upon a bottom of the light guide seat (11), and an outer peripheral surface of the revolving fasten portion (52) is formed a seal rib (521) shaped in helical.
9. The luminous bottle stopper according to any of the claims 1 to 8, wherein the flexible sleeve (50) is formed a light guide slot (501) shaped in helical and corresponded to the light guide rib (121), and the light guide rib (121) is located in the light guide slot (501).

Patentansprüche

1. Ein leuchtender Flaschenverschluss zum Einstecken in eine Flaschenmündung (2), bestehend aus:

einen Lichtleiterkörper (10) aus lichtdurchlässigem Material, wobei der Lichtleiterkörper (10) einen Lichtleitersitz (11) und eine Lichtleitersäule (12), die mit dem Lichtleitersitz (11) verbunden ist, aufweist und der Lichtleitersitz (11) einen Aufnahmeraum (110) hat;

ein lichtemittierendes Modul (20), das in dem Aufnahmeraum (110) installiert ist, wobei das lichtemittierende Modul (20) eine Leiterplatte (21) und ein lichtemittierendes Element (22) enthält, das elektrisch mit der Leiterplatte (21) verbunden ist;

ein Leistungsmodul (30), das in dem Aufnahmeraum (110) installiert ist, wobei das Leistungsmodul (30) mindestens eine Batterie (31) und ein Leitelement (32) umfasst, das elektrisch mit der mindestens einen Batterie (31) verbunden ist;

eine Stopperabdeckung (40), die mit dem Lichtleitersitz (11) kombiniert ist und den Aufnahmeraum (110) abdichtet; und

eine biegsame Hülse (50) aus lichtdurchlässigem Material, wobei die biegsame Hülse (50) auf die Lichtleitersäule (12) aufgeschoben ist

und in die Mündung (2) der Flasche eingesteckt werden kann, **dadurch gekennzeichnet, dass** eine äußere Umfangsfläche der Lichtleitersäule (12) mit einer schraubenförmig geformten Lichtleiterrippe (121) ausgebildet ist.

2. Der leuchtende Flaschenverschluss nach Anspruch 1, wobei eine äußere Umfangsfläche der Lichtleitersäule (12) Texturen, aufgedruckte Adern oder eingritzte Lichtleitlinien (120) aufweist.

3. Der leuchtende Flaschenverschluss nach einem der Ansprüche 1 bis 2, ferner umfassend einen Dichtungsring (60), wobei der Dichtungsring (60) zwischen dem Lichtleitersitz (11) und dem Stopperabdeckung (40) angeordnet ist; der Lichtleitersitz (11) in dem Aufnahmeraum (110) eine Ringnut (111) ausgebildet ist und der Stopperabdeckung (40) eine entsprechend oberhalb der Ringnut (111) angeordnete Pressplatte (401) aufweist; der Dichtungsring (60) in der Ringnut (111) angeordnet und durch die Pressplatte (401) gepresst ist.

4. Der leuchtende Flaschenverschluss nach einem der Ansprüche 1 bis 3, wobei der Lichtleitersitz (11) einen Lichtleitwinkel (113) aufweist, der an eine Seite der Lichtleitersäule (12) angrenzt; eine Innenwand des Lichtleitersitzes (11) ist ferner mit einer reflektierenden Schicht (114) versehen.

5. Der leuchtende Flaschenverschluss nach Anspruch 3 oder 4, wobei an einer Innenwand des Lichtleitersitzes (11) eine Vielzahl von Widerstandsrippen (112) an einem Boden der ringförmigen Nut (111) ausgebildet ist und die Widerstandsrippen (112) fest an der Stopperabdeckung (40) angebracht sind; die Stopperabdeckung (40) eine Abdeckplatte (41) und eine Vielzahl von mit der Abdeckplatte (41) verbundenen Stützplatten (42) umfasst und die Widerstandsrippen (112) an einer Außenseite der Stützplatte (42) anliegen.

6. Der leuchtende Flaschenverschluss nach Anspruch 5, wobei die Abdeckplatte (41) eine Kerbe (410) aufweist und die Abdeckplatte (41) einen Positionierungsabschnitt (411) in der Kerbe (410) aufweist; der leuchtende Flaschenverschluss (1) ist relativ zur Flaschenmündung (2) beweglich, indem er auf den Positionierungsabschnitt (411) drückt.

7. Der leuchtende Flaschenverschluss nach einem der Ansprüche 1 bis 6, wobei das lichtemittierende Modul (20) ferner einen Lagersitz (23) aufweist und der Lagersitz (23) die Leiterplatte (21) trägt und ein Durchgangsloch (230) aufweist, das dem lichtemittierenden Element (22) entspricht; wobei ein Teil des lichtemittierenden Elements (22) in dem Durchgangsloch (230) und ein anderer Teil davon in dem

Lichtleitersitz (11) angeordnet ist.

8. Der leuchtende Flaschenverschluss nach einem der Ansprüche 1 bis 7, wobei die flexible Hülse (50) einen Halteabschnitt (51) und einen Drehbefestigungsabschnitt (52) aufweist; der Halteabschnitt (51) liegt an einem Boden des Lichtleitersitzes (11) an, und eine äußere Umfangsfläche des Drehbefestigungsabschnitts (52) ist mit einer schraubenförmig geformten Dichtungsrippe (521) versehen.
9. Der leuchtende Flaschenverschluss nach einem der Ansprüche 1 bis 8, wobei die flexible Hülse (50) einen schraubenförmigen Lichtleitschlitz (501) aufweist, der mit der Lichtleitrippe (121) korrespondiert, und die Lichtleitrippe (121) in dem Lichtleitschlitz (501) angeordnet ist.

Revendications

1. Un bouchon de bouteille alumineux à boucher dans un goulot (2) d'une bouteille, comprenant :

un corps de guide de lumière (10) fait d'un matériau transmettant la lumière, le corps de guidage de lumière (10) comprenant un siège de guidage de lumière (11) et une colonne de guidage de lumière (12) se raccordant au siège de guidage de lumière (11), et le siège de guidage de lumière (11) ayant un espace de logement (110);

un module d'émission de lumière (20) installé dans l'espace de logement (110), le module d'émission de lumière (20) comprenant une carte de circuit (21) et un élément électroluminescent (22) connecté électriquement à la carte de circuit (21);

un module d'alimentation (30) installé dans l'espace de logement (110), le module d'alimentation (30) comprenant au moins une batterie (31) et un élément conducteur (32) connecté électriquement à la ou aux batterie(s) (31);

un couvercle de bouchon (40) combiné avec le siège de guidage de lumière (11) et scellé dans l'espace de logement (110); et

un manchon souple (50) en matériau transmettant la lumière, le manchon souple (50) étant emmanché sur la colonne de guidage de lumière (12) et apte à être enfiché dans l'embouchure (2) de la bouteille, **caractérisé en ce qu'**une surface périphérique extérieure de la colonne de guidage de lumière (12) est formée d'une nervure de guidage de lumière (121) de forme hélicoïdale.

2. Le bouchon de bouteille lumineux selon la revendication 1 ou 2, dans lequel une surface périphérique

extérieure de la colonne de guidage de lumière (12) a des textures, des veines imprimées ou des lignes de guidage de lumière sculptées (120).

3. Le bouchon de bouteille lumineux selon l'une quelconque des revendications 1 à 2, comprenant en outre une bague d'étanchéité (60), dans laquelle la bague d'étanchéité (60) est disposée entre le siège de guidage de lumière (11) et le couvercle de bouchon (40); le siège de guidage de lumière (11) est formé d'une rainure annulaire (111) dans l'espace de logement (110) et le couvercle de bouchon (40) a une plaque de pression (401) disposée de manière correspondante au-dessus de la rainure annulaire (111); la bague d'étanchéité (60) étant disposée dans la rainure annulaire (111) et pressée par la plaque de pression (401).

4. Le bouchon de bouteille lumineux selon l'une quelconque des revendications 1 à 3, dans lequel le siège de guidage de lumière (11) a un angle de guidage de lumière (113) voisin d'un côté de la colonne de guidage de lumière (12); une paroi intérieure du siège de guidage de lumière (11) est en outre pourvue d'une couche réfléchissante (114).

5. Le bouchon de bouteille lumineux selon la revendication 3 ou 4, dans lequel une paroi intérieure du siège de guidage de lumière (11) est formée d'une pluralité de nervures de résistance (112) au fond de la rainure annulaire (111), et les nervures de résistance (112) sont solidement fixées au couvercle de bouchon (40); le couvercle de bouchon (40) comprenant une plaque de couverture (41) et une pluralité de plaques de support (42) connectées à la plaque de couverture (41), et les nervures de résistance (112) butent contre un côté extérieur de la plaque de support (42).

6. Le bouchon de bouteille lumineux selon la revendication 5, dans lequel la plaque de couverture (41) a une encoche (410), et la plaque de couverture (41) est formée d'une partie de positionnement (411) dans l'encoche (410); le bouchon de bouteille lumineux (1) étant mobile par rapport au goulot (2) de la bouteille en s'exerçant sur la partie de positionnement (411).

7. Le bouchon de bouteille lumineux selon l'une quelconque des revendications 1 à 6, dans lequel le module émetteur de lumière (20) comprend en outre un siège de support (23) et le siège de support (23) porte la carte de circuit (21) et a un trou traversant (230) correspondant à l'élément électroluminescent (22); une partie de l'élément électroluminescent (22) est située dans le trou traversant (230) et une autre partie de celui-ci est située dans le siège de guidage de lumière (11).

8. Le bouchon de bouteille lumineux selon l'une quelconque des revendications 1 à 7, dans lequel le manchon flexible (50) comprend une partie de maintien (51) et une partie de fixation tournante (52); la partie de maintien (51) est en butée sur un fond du siège de guidage de lumière (11), et une surface périphérique extérieure de la partie de fixation tournante (52) est formée d'une nervure d'étanchéité (521) de forme hélicoïdale.
9. Le bouchon de bouteille lumineux selon l'une quelconque des revendications 1 à 8, dans lequel le manchon flexible (50) est formé d'une fente de guidage de lumière (501) de forme hélicoïdale et correspond à la nervure de guidage de lumière (121), et la nervure de guidage de lumière (121) est située dans la fente de guidage de lumière (501).

5

10

15

20

25

30

35

40

45

50

55

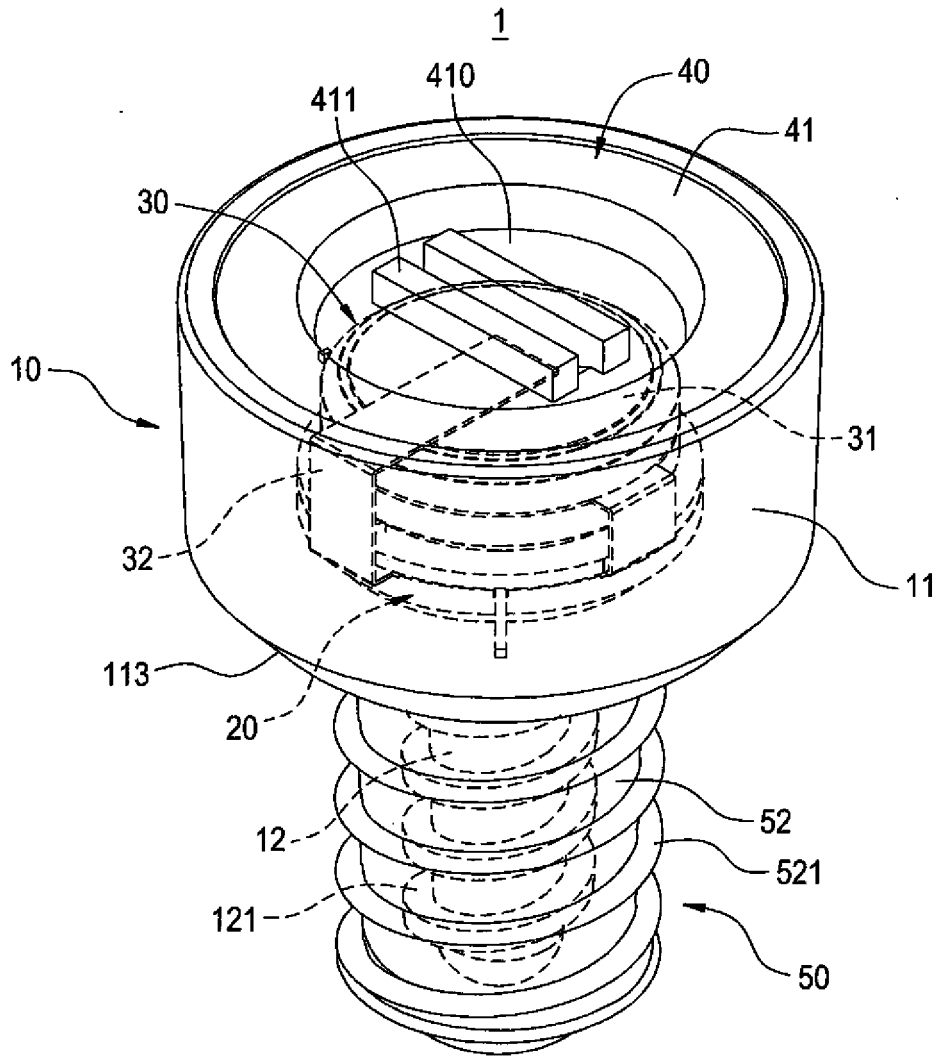

FIG.1

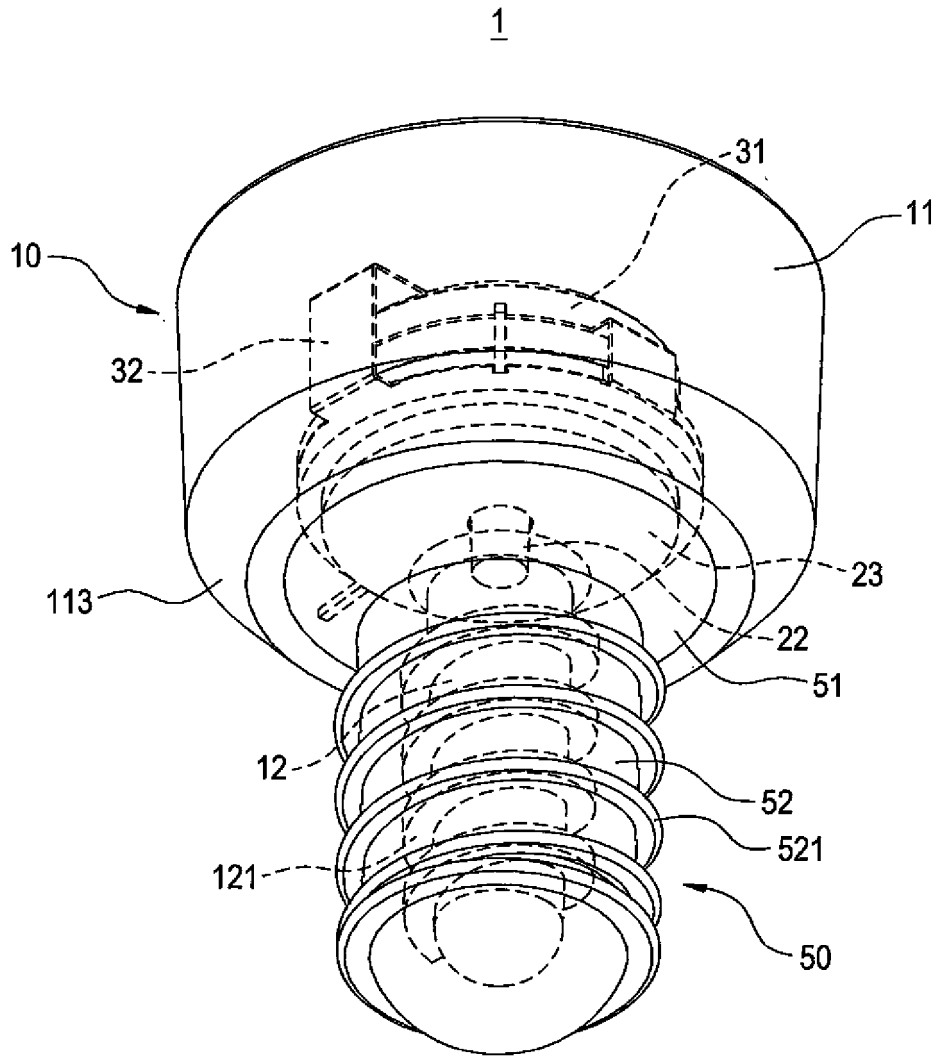

FIG.2

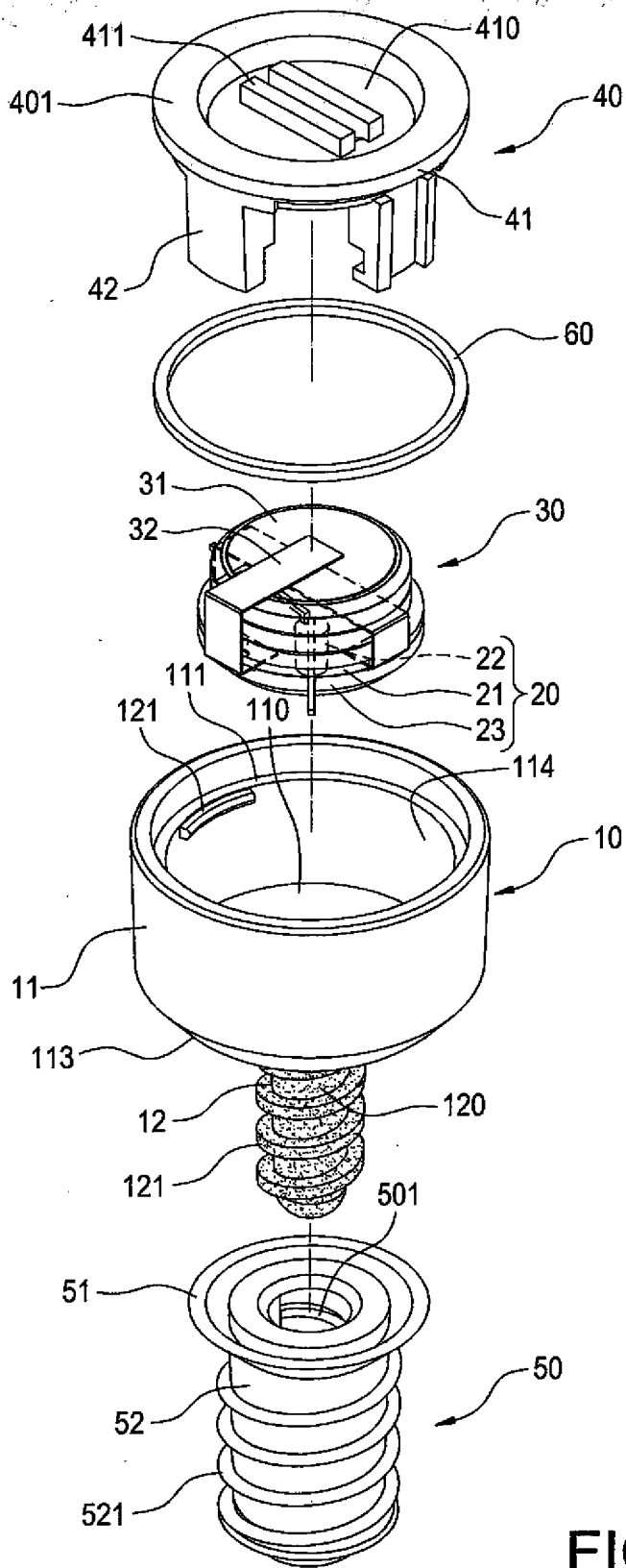

FIG.3

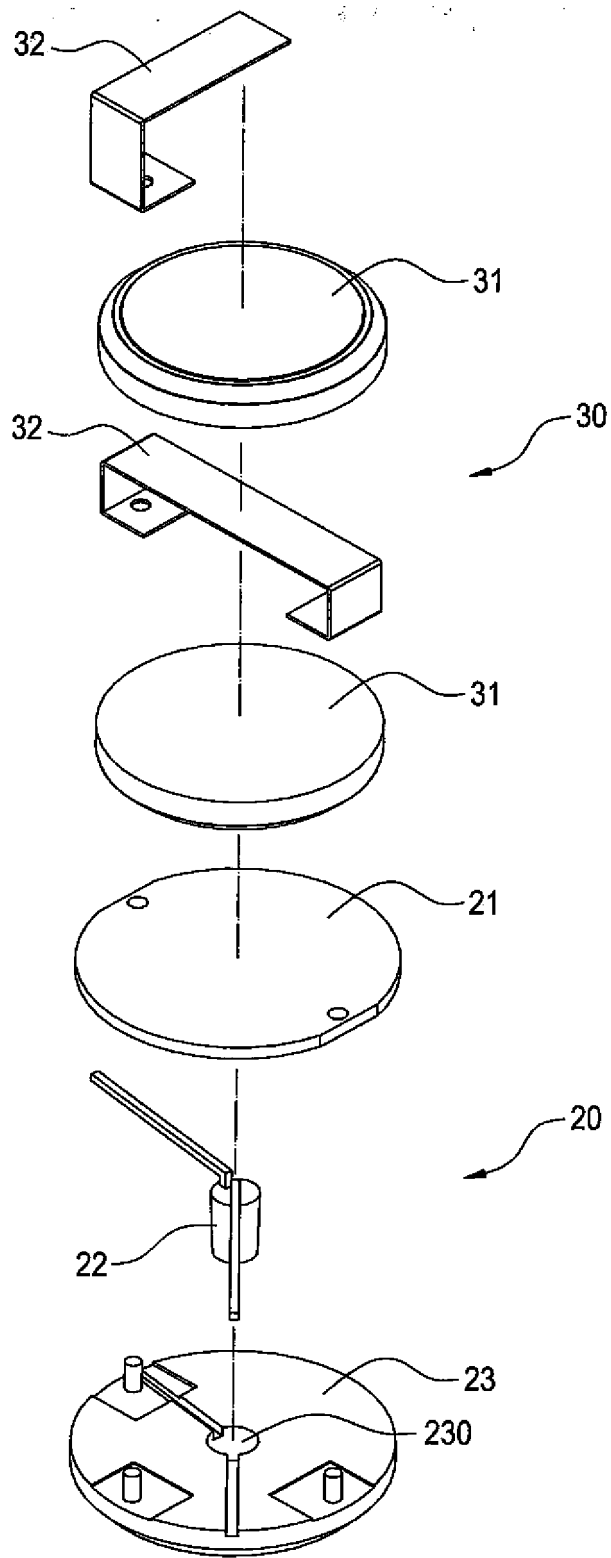

FIG.4

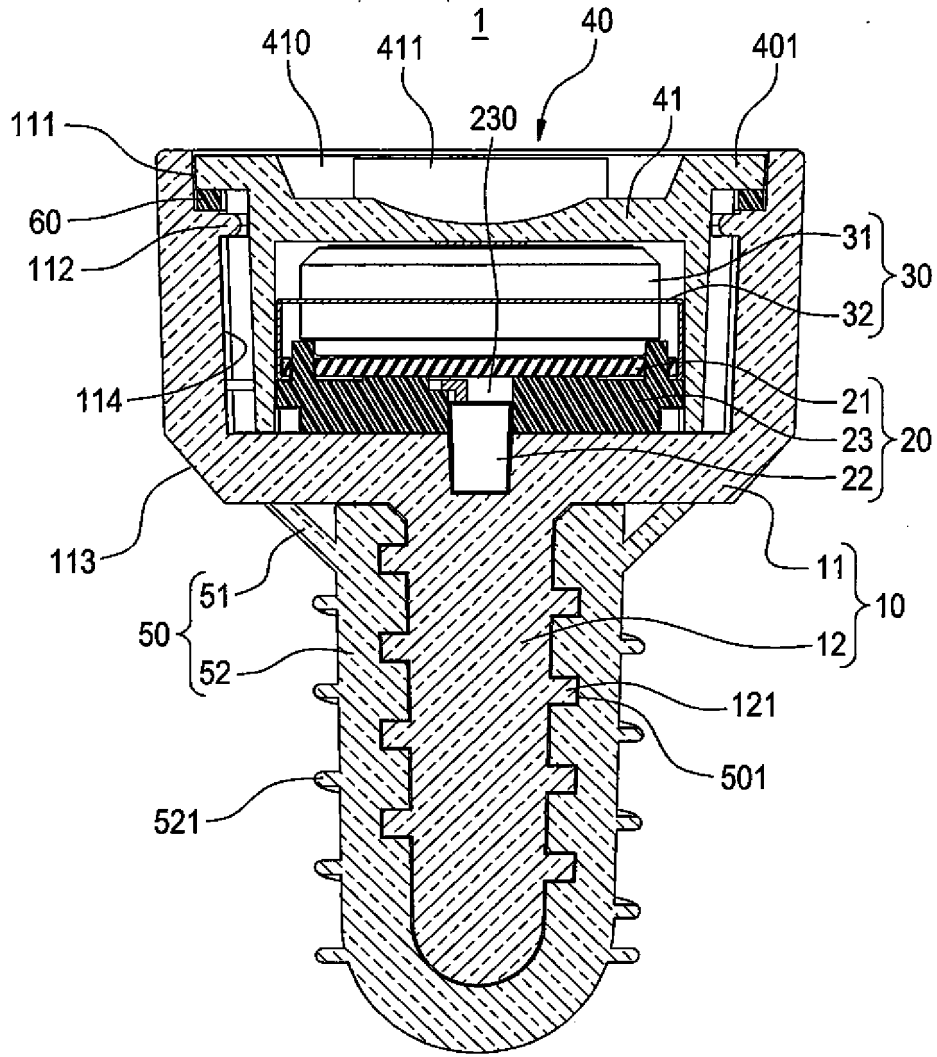

FIG.5

REFERENCES CITED IN THE DESCRIPTION

This list of references cited by the applicant is for the reader's convenience only. It does not form part of the European patent document. Even though great care has been taken in compiling the references, errors or omissions cannot be excluded and the EPO disclaims all liability in this regard.

Patent documents cited in the description

- US 2015217912 A1 [0003]
- DE 202008001443 [0004]