



(12) **EUROPEAN PATENT APPLICATION**

(88) Date of publication A3:  
**02.07.2003 Bulletin 2003/27**

(51) Int Cl.7: **B65D 21/00**

(43) Date of publication A2:  
**07.11.2001 Bulletin 2001/45**

(21) Application number: **00204321.4**

(22) Date of filing: **04.12.2000**

(84) Designated Contracting States:  
**AT BE CH CY DE DK ES FI FR GB GR IE IT LI LU  
MC NL PT SE TR**  
Designated Extension States:  
**AL LT LV MK RO SI**

(72) Inventors:  
• **Earnhart, Edgar G. c/o Eastman Kodak Company  
Rochester, New York 14650-2201 (US)**  
• **Burns, Parker J., c/o Eastman Kodak Company  
Rochester, New York 14650-2201 (US)**

(30) Priority: **15.12.1999 US 464489**

(74) Representative:  
**Lewandowsky, Klaus, Dipl.-Ing. et al  
Kodak Aktiengesellschaft,  
Patentabteilung  
70323 Stuttgart (DE)**

(54) **Stackable container and method of forming same**

(57) A stackable container (10) has a container body with a closed base (16), upstanding side walls (18) surrounding the closed base (16) and an opening (20) opposite the base (16) for accessing the interior compartment of the container body. A closure (22) arrangeable about the body for closing the opening (20) has a recess (24) having an interior dimension and a stacking rim (26) surrounding the recess (24) for receiving the closed base (16) and a portion of the upstanding side walls (18).

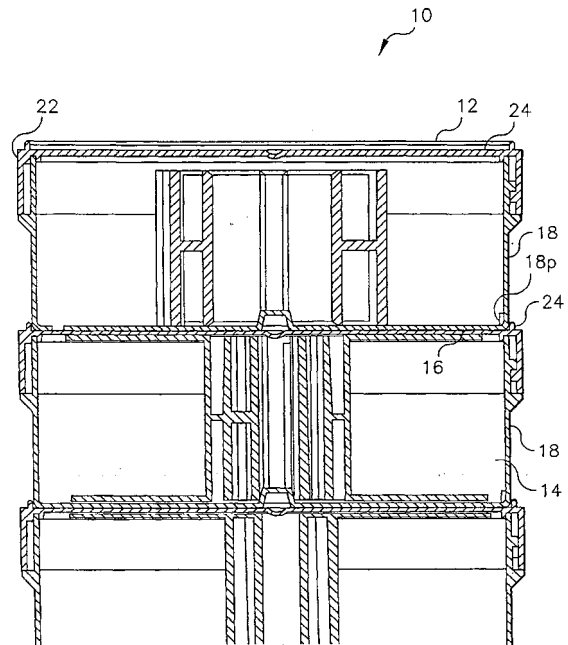

FIG. 1



European Patent  
Office

## EUROPEAN SEARCH REPORT

Application Number  
EP 00 20 4321

DOCUMENTS CONSIDERED TO BE RELEVANT			
Category	Citation of document with indication, where appropriate, of relevant passages	Relevant to claim	CLASSIFICATION OF THE APPLICATION (Int.Cl.7)
X	US 4 961 512 A (VON HOLDT JOHN W) 9 October 1990 (1990-10-09) * column 2, line 47 - line 64; figures 1,2,4 *	1-7	B65D21/00
X	EP 0 124 212 A (BECTON DICKINSON CO) 7 November 1984 (1984-11-07) * abstract; figures 1,4,6,8 * * page 6, line 9 - line 12 * * page 8, line 4 - line 6 *	1-7	
X	DE 946 273 C (ZEILER PACKUNGEN A G) 26 July 1956 (1956-07-26) * page 2, line 67 - line 119; claim 1; figures 1,2 *	1-4,7	
A	US 2 695 115 A (ROOP NATHAN W) 23 November 1954 (1954-11-23) * claim 1; figures 1,2 *	1,2	
A	JP 07 237633 A (TAKASHI KONDO) 12 September 1995 (1995-09-12) * figures 1,2 *	1	
			TECHNICAL FIELDS SEARCHED (Int.Cl.7)
			B65D G03C
The present search report has been drawn up for all claims			
Place of search		Date of completion of the search	Examiner
MUNICH		29 April 2003	Segerer, H
CATEGORY OF CITED DOCUMENTS			
X : particularly relevant if taken alone Y : particularly relevant if combined with another document of the same category A : technological background O : non-written disclosure P : intermediate document		T : theory or principle underlying the invention E : earlier patent document, but published on, or after the filing date D : document cited in the application L : document cited for other reasons & : member of the same patent family, corresponding document	

EPO FORM 1503 03.82 (P04C01)

**ANNEX TO THE EUROPEAN SEARCH REPORT  
ON EUROPEAN PATENT APPLICATION NO.**

EP 00 20 4321

This annex lists the patent family members relating to the patent documents cited in the above-mentioned European search report. The members are as contained in the European Patent Office EDP file on the European Patent Office is in no way liable for these particulars which are merely given for the purpose of information.

29-04-2003

Patent document cited in search report		Publication date	Patent family member(s)	Publication date
US 4961512	A	09-10-1990	NONE	
-----				
EP 0124212	A	07-11-1984	AU 569057 B2	21-01-1988
			AU 2396684 A	08-11-1984
			DE 3461481 D1	15-01-1987
			DK 89284 A ,B,	03-11-1984
			EP 0124212 A1	07-11-1984
			FI 840732 A ,B,	03-11-1984
			JP 1451036 C	25-07-1988
			JP 59203489 A	17-11-1984
			JP 62060065 B	14-12-1987
			US 5021351 A	04-06-1991
-----				
DE 946273	C	26-07-1956	NONE	
-----				
US 2695115	A	23-11-1954	NONE	
-----				
JP 07237633	A	12-09-1995	NONE	
-----				