

⑫ **EUROPEAN PATENT SPECIFICATION**

- ④⑤ Date of publication of patent specification: **25.05.88**      ⑤① Int. Cl.<sup>4</sup>: **B 26 B 13/04, B 26 B 13/00**  
⑦① Application number: **84307261.2**  
⑦② Date of filing: **22.10.84**

---

⑤④ **Cutting device.**

---

③① Priority: **28.10.83 GB 8328870**

④③ Date of publication of application:  
**05.06.85 Bulletin 85/23**

④⑤ Publication of the grant of the patent:  
**25.05.88 Bulletin 88/21**

⑧④ Designated Contracting States:  
**AT BE CH DE FR IT LI LU NL SE**

⑤⑥ References cited:  
**DD-A- 91 623**  
**FR-A- 961 388**  
**GB-A- 14 120**  
**GB-A- 610 035**  
**GB-A-1 445 305**  
**GB-A-2 128 125**  
**US-A- 843 667**  
**US-A-3 846 910**

⑦③ Proprietor: **RUSSELL (SHEARS) LIMITED**  
**Infirmay Road**  
**Rawmarsh New Rotherham, S62 2BB (GB)**

⑦② Inventor: **Quick, Nicholas John**  
**80 Carless Avenue**  
**Harborne Birmingham, B17 9BM (GB)**

⑦④ Representative: **Jones, Graham H.**  
**Graham Jones & Company**  
**77 Beaconsfield Road Blackheath**  
**London SE3 7LG (GB)**

---

Note: Within nine months from the publication of the mention of the grant of the European patent, any person may give notice to the European Patent Office of opposition to the European patent granted. Notice of opposition shall be filed in a written reasoned statement. It shall not be deemed to have been filed until the opposition fee has been paid. (Art. 99(1) European patent convention).

## Description

This invention relates to cutting devices having pivoted cutters which operate with shear action.

Cutting devices such as scissors and shears comprising a pair of blades which operate with a shear action about a pivot are well known. It is also well known to provide scissors in which cutters made of steel are secured to plastics handle portions.

In GB—A—610035, there is described a cutting device having pivoted cutters which operate with a shear action, which cutting device comprises a pair of cutters, a pair of handle portions one for each cutter of the pair, and a pivot pin means which enables the cutters to be mutually pivoted and held together, the cutters each having a blade body portion having a pivot pin hole therein for the pivot pin means and a blade edge portion which extends obliquely from the blade body portion longitudinally of the blade body portion from the end thereof remote from the handle portions to a region before the pivot pin hole. In GB—A—610035, it is further disclosed that the cutters may be made of a metal and the handle portions may be made of a plastics material. With such a construction, the cutting device described in GB—A—610035 can snap across the pivot pin hole if too much pressure is applied to the handle portions. This is because the pivot pin hole extends through the handle portions and weakens the handle portions at this point. Handle portions made of steel could possibly tolerate this weakening. However handle portions made of a plastics material often cannot tolerate this weakening and one or other of the handle portions may often snap off if the handle portions are squeezed together too hard.

It is an aim of the present invention to provide a particularly rugged cutting device of the kind having pivoted cutters which operate with a shear action, which cutting device is able to handle portions made of a plastics material so that the manufacturing and lightweight advantages of using a plastics material can be obtained whilst providing a cutting device which is not subject to one or other of the handle portions breaking.

Accordingly, this invention provides a cutting device having pivoted cutters which operate with a shear action, which cutting device comprises a pair of cutters, a pair of handle portions one for each cutter of the pair, and a pivot pin means which enables the cutters to be mutually pivoted and held together, the cutters each having a blade body portion having a pivot pin hole therein for the pivot means and a blade edge portion which is for effecting a cutting action, the cutters being made of a metal, and the handle portions being made of a plastics material which extends partially over the metal of the cutters, characterised in that the blade edge portion extends obliquely from the blade body portion from the end thereof remote from the handle portions to a region beyond the pivot pin hole.

Because each blade edge portion extends to the

region beyond the pivot pin hole, it is able to reinforce the cutting device and especially the handle portions in the region of the pivot pin hole and snapping of the handles, even under severe squeezing pressure, can be prevented.

Preferably, each cutter is provided with keying means for causing the cutter to key to the plastics material. The metal for the cutters will usually be steel and the keying means may be, for example, holes, slots, notches or projecting portions such as lugs.

By arranging that the blade edge portion extends along the blade body portion to beyond the pivot pin holes, the blade body portion is thereby strengthened and any risk of fracturing of the blade body portion in the region of the pivot pin hole is thereby substantially obviated.

The blade edge portion may extend beyond that end of the blade body portion remote from the handle portions.

The blade edge portion may be tapered so as to be thicker at the end remote from the handle portions. This facilitates a good cutting action.

Preferably, at least one of the cutters is bent towards the other. If desired, both cutters may be bent towards each other. This bending also facilitates a good cutting action.

The bending may occur about a line near the pivot pin and on the cutter side of the pivot pin. The bending of the cutters may be regarded as preloading the cutters. As the cutters cross to cut, they can flex slightly against the preloading. By way of example only, it is mentioned that with a pair of scissors having blades that are approximately 4½ inches (i.e. 112.5 millimetres long), one blade may be bent inwardly by ¼ inch (i.e. 6.25 millimetres), or both blades may be bent inwardly by ½ inch (i.e. 3.125 millimetres).

The blade or blades are preferably bent inwardly by a press. The press may be a power press or a hand press. Alternatively, the blades may be bent inwardly by induction hardening. Each blade being bent is normally clamped around its pivot pin hole during the bending. The bending may be effected as a separate operation or as part of one of the other operations in the manufacture of the scissors.

The blade edge portion and the blade body portion may be press formed from a steel blank.

The blade edge portion may be hardened as by means of a laser hardening process or by means of an induction hardening process. For example, the blade edges may be characterised by a Rock-wall hardness figure of the order of 56.

Some embodiments of the invention will now be described solely by way of example and with reference to the accompanying drawings in which:

Figure 1 is an exploded perspective view of a pair of scissors;

Figure 2 is an exploded perspective view of cutters which form a part of the scissors shown in Figure 1;

Figure 3 is an enlarged sectional view through line XX shown in Figure 1;

Figure 4 is an enlarged sectional view through line YY as shown on Figure 1;

Figure 5 is a perspective view of a clip for use with the scissors shown in Figures 1, 2 and 3; and

Figure 6 is a perspective view of an alternative form of the clips shown in Figure 5.

Referring now to the drawings, a pair of scissors comprises a first member 2 and a second member 4 pivoted about a pin 6 which fits within a bush 6a. The member 2 comprises a moulded plastics handle 8 and a steel cutter 10. Similarly, the member 4 comprises a moulded plastics handle 12 and a steel cutter 14. The handle 8 has a thumb hole 8a and the handle 12 has a finger hole 12a. The cutter 10 is embedded in plastics material 11 forming a part of the handle 8 and the cutter 10 is also provided with an extension piece 13 which extends into the handle 8 and around which the handle 8 is moulded. Similarly, the cutter 14 is embedded in plastics material 15 and the cutter 14 is also provided with an extension piece 17 which extends into the handle 12 and around which the handle 12 is moulded.

The cutter 10 is press formed from a steel blank and it has a flat blade body portion 3 from which a blade edge portion 5 is arranged to extend obliquely. The cutter 14 is similarly formed and fabricated, and it has a flat blade body portion 7 and a blade edge portion 9. Holes 19 and 21 are formed in the blade body portions 3 and 7 respectively to receive the pin 6 about which they are pivoted. Other holes 23 are formed in the blade body portions 3 and 7 to receive the plastics material 11 and so enable a good key to be provided between the cutters 10, 14 and their respective plastic handles 8, 12.

As can be seen most clearly in Figure 2, the blade edge portions 5 and 9 are arranged to extend longitudinally of their respective blade body portions 3 and 7 to beyond the holes 19 and 21 whereby the regions of the blade body portions 3 and 7 around the holes 19 and 21 respectively, are strengthened. This extension of the blade edge portions 9 and 13 thus serve to strengthen the cutters 10 and 14 and to facilitate the provision of scissors suitable for rugged use.

The blade edge portions 5 and 9 are tapered so that they are slightly thicker at their ends remote from the extension pieces 13 and 17 to improve end cutting action. The end cutting action is also improved by bending one or both of the entire cutters 10, 14 towards each other, for example about one or both of the crink lines 10a, 14a shown in Figure 2.

The blade edge portions 5 and 9 are hardened as by laser hardening or induction hardening to give a Rockwell figure of about 56. The blade edge portions 5 and 9 cut well due the blade edge hardening but they tend to become slightly brittle. The brittleness does not matter however as the body portions 3 and 7 are not hardened so that the body portions 3 and 7 do not become brittle. Obviously, if brittleness is not a governing factor, then the entire cutters 10, 14 can be hardened.

Obviously the blade edge portions 5 and 9 of the cutters 10, 14 respectively extend proud of the plastics material (as shown in Figure 3) so that they can effect a cutting action.

The diameter of one end portion of the pin 6 is reduced to define a spigot 16, the spigot 16 being peened or spun over to define an abutment part in the form of a rivet head 18. The rivet head 18 serves to secure the cutter 14 in position on the pin 6. The cutter 10 is held in position on the pin 6 by means of a slotted clip 20. The clip 20 is located in a circumferential groove 22 which is formed in the pin 6 at its other end portion. The clip 20 comprises a flat strip having a wider slotted end part 21 which includes an elongate slot 24 in which the pin 6 is accommodated. The slot 24 may either have an open end 26 as shown in Figure 6 or it may extend to define a circular aperture 28 as shown in Figure 5. The clip 20 may be made of a metal such for example as spring steel.

In use of the clip 20 shown in Figure 5, the circular aperture 28 is placed over the pin 6 whereby the slotted end part 21 of the clip 20 can be slid on to the complementary groove 22 in the pin 6. In use of the clip 20 shown in Figure 6, since the slot 24 has an open end 26, the open end 26 facilitates positioning of the slotted end part 21 of the clip 20 in the groove 22 of the pin 6.

The strip material which defines the clip 20 is bent back on itself to form a limb 29 which lies parallel with the slotted end part 21 of the clip 20 and which is further bent to define an end portion 30 which includes a projection 32. The handle 8 in which the cutter 10 is secured, is provided with a pair of undercut grooves 34 in which the wider slotted end part 21 of the clip 20 is accommodated. The cutter 10 is provided with a recess 36 (see Figure 4) in which the projection 32 is received to lock the clip 20 in position. The recess 36 is associated with a raised portion 38 which separates it from another recess 40. Thus the clip 20 may be constrained to slide from a first position whereat the projection 32 is engaged in the recess 40, to a second position whereat the projection 32 is engaged in the recess 36, the projection 32 being required to ride over the raised portion 38 as it is constrained to slide from the first to the second position.

It will be appreciated that if the clip 20 of Figure 5 is used, when the clip 20 is in the first position, it may be removed from the pin 6 since the aperture 28 will align with the end of the pin 6. Alternatively, if the clip 20 as shown in Figure 6 is used, the pin 6 will lie between the projection 32 and an end of the clip 20 when it is in the first position and thus will be clear of the slot 24 such that the scissors can be easily dismantled for sharpening purposes for example and can easily be assembled during manufacture.

The handle 8 is provided with a stop member 39 which is effective to keep the handle 8, 12 slightly apart during a cutting action and thereby to prevent a user of the scissor from trapping their skin between the handles 8, 12 as the cutters 10,

5

10

15

20

25

30

35

40

45

50

55

60

65

14 close and cut. During scissor manufacture, the stop member 39 also helps to align the tips of the blades on the first assembly of the scissors, removal of a small amount of plastics material from the stop member 39 being effected until the tips of the scissors 10, 14 align.

The scissors as just before described, although suitable for heavy duty work, may be used for any desired purposes so that they may be for example household scissors, hairdressing scissors, clothes making scissors, surgical scissors, or manicure scissors. Since the cutters may be press formed from a steel blank, they may quickly and easily be fabricated with a minimum of production time.

Various modifications may also be made to the scissors hereinbefore described without departing from the scope of the invention. For example, the extra width of the wider slotted end part 21 of the clip 20 could be continued to either of bends 42, 44 or 46 if desired. Further, different shapes may be employed for the pin 6, and the pin 6 and the bush 6a may be formed as a single member. If desired, with some pivots, the blade edge portions 5 and 9 could taper the other way to that illustrated. A simple bent over pivot pin may be employed to obviate the need for the clip 20. Although the recesses 36, 40 and the raised portion 38 are shown as being formed integrally with the cutter 10, they could be separately formed if desired, for example from a plastics material. The holes 23 could be omitted or they could be replaced by slots, by other shaped holes, or by projecting portions such as lugs. The scissors may also be another type of twin bladed cutting device, for example a pair of shears. Further, the blades may be replaceable blades.

#### Claims

1. A cutting device having pivoted cutters, which operate with a shear action, which cutting device comprises a pair of cutters (10, 14), a pair of handle portions (8, 12) one for each cutter (10, 14) of the pair, and a pivot pin means (6) which enables the cutters (10, 14) to be mutually pivoted and held together, the cutters (10, 14) each having a blade body portion (3, 7) having a pivot pin hole (19, 21) therein for the pivot pin means (6) and a blade edge portion (5, 9) which is for effecting a cutting action, the cutters (10, 14) being made of metal, and the handle portions (8, 12) being made of a plastics material which extends partially over the metal of the cutters (10, 14), characterised in that the blade edge portion (5, 9) extends obliquely from the blade body portion (3, 7) longitudinally of the blade body portion (3, 7) from the end thereof remote from the handle portions (8, 12) to a region beyond the pivot pin hole (19, 21).

2. A cutting device according to claim 1 characterised in that each cutter (10, 14) is provided with keying means (23) for causing the cutter (10, 14) to key the plastics material.

3. A cutter device according to claim 2 charac-

terised in that the keying means (23) is at least one hole, slot, notch, or projecting portion.

4. A cutting device according to any one of the preceding claims characterised in that the blade edge portion (5, 9) extends beyond that end of the blade body portion (3, 7) remote from the handle portions (8, 12).

5. A cutting device according to any one of the preceding claims characterised in that the blade edge portion (5, 9) is tapered so as to be thicker at the end remote from the handle portions (8, 12).

6. A cutting device according to any one of the preceding claims characterised in that at least one of the cutters (10, 14) is bent towards the other.

7. A cutting device according to any one of the preceding claims characterised in that the blade edge portion (5, 9) and the blade body portions (3, 7) are press formed from a steel blank.

8. A cutting device according to any one of the preceding claims characterised in that the blade edge portion (5, 9) is hardened.

9. A cutting device according to claim 8 characterised in that the blade edge portion (5, 9) is hardened by a laser hardening process or by an induction hardening process.

#### Patentansprüche

1. Schneidvorrichtung mit schwenkbaren Schneidelementen, die mit Scherung wirkt, wobei diese Schneidvorrichtung zwei Schneidelemente (10, 14) enthält, zwei Griffteile (8, 12), jeweils einen für jedes Schneidelement (10, 14), enthält und einen Gelenkzapfen (6) enthält, der die Schneidelemente (10, 14) gegenseitig verschwenkbar zusammenhält, wobei ferner jedes Schneidelement (10, 14) einen Messerkörperteil (3, 7) aufweist, der jeweils ein Gelenkzapfen-Loch (19, 21) für den Gelenkzapfen (6) aufweist und einen Messerkantenteil (5, 9) aufweist, der den Schneidvorgang bewirkt, wobei des weiteren die Schneidelemente (10, 14) aus einem Metall hergestellt sind und die Griffteile (8, 12) aus einem Kunststoffmaterial hergestellt sind, welches sich teilweise über das Metall der Schneidelemente (10, 14) erstreckt, dadurch gekennzeichnet, daß der Messerkantenteil (5, 9) sich schräg weg von dem Messerkörperteil (3, 7) und entlang des Messerkörperteils (3, 7) der Länge nach von einem den Griffteilen (8, 12) entfernten Ende zu einem Bereich jenseits des Gelenkzapfen-Lochs (19, 21) hin erstreckt.

2. Schneidvorrichtung nach Anspruch 1, dadurch gekennzeichnet, daß jedes Schneidelement (10, 14) mit einem Verkeilmittel (23) versehen ist, damit das Schneidelement (10, 14) mit dem Kunststoffmaterial verkeilt werden kann.

3. Schneidvorrichtung nach Anspruch 2, dadurch gekennzeichnet, daß das Verkeilmittel (23) zumindest ein Loch, ein Schlitz eine Kerbe oder ein herausragender Teil ist.

4. Schneidvorrichtung nach einem der vorstehenden Ansprüche, dadurch gekennzeichnet,

daß der Messerkantenteil (5, 9) sich jenseits des von den Griffteilen (8, 12) entfernten Endes des Messerkörperteils (3, 7) erstreckt.

5. Schneidvorrichtung nach einem der vorstehenden Ansprüche, dadurch gekennzeichnet, daß der Messerkantenteil (5, 9) derart konisch zulaufend ist, daß er an dem dem Griffteil (8, 12) entfernten Ende dicker ist.

6. Schneidvorrichtung nach einem der vorstehenden Ansprüche, dadurch gekennzeichnet, daß eines der Schneidelemente (10, 14) zum anderen hin gekrümmt ist.

7. Schneidvorrichtung nach einem der vorstehenden Ansprüche, dadurch gekennzeichnet, daß der Messerkantenteil (5, 9) und die Messerkörperteile (3, 7) aus einem Stahlrohrung preßageformt sind.

8. Schneidvorrichtung nach einem der vorstehenden Ansprüche, dadurch gekennzeichnet, daß der Messerkantenteil (5, 9) gehärtet ist.

9. Schneidvorrichtung nach Anspruch 8, dadurch gekennzeichnet, daß der Messerkantenteil (5, 9) mittels eines Laser-Härteverfahrens oder eines Induktions-Härteverfahrens gehärtet worden ist.

#### Revendications

1. Dispositif de découpage comportant des lames pivotantes, qui agissent par une action de cisaillement, ce dispositif de découpage comprenant une paire de lames (10, 14), une paire de parties formant poignées (8, 12), une poignée étant prévue pour chaque lame (10, 14) de la paire de lames, et un dispositif formant axe de pivotement (6) qui permet aux lames (10, 14) d'être maintenues ensemble et d'être amenées à pivoter entre elles, les lames (10, 14) comportant chacune une partie formant corps de lame (3, 7) présentant un trou d'axe de pivotement (19, 21) pour le dispositif à axe de pivotement (6) et une partie formant bord de lame (5, 9) qui est prévue pour assurer une action de découpage, les lames (10, 14) étant faites de métal, tandis que les parties formant poignées (8, 12) sont faites d'une matière plastique qui s'étend partiellement par-dessus le métal des lames (10, 14), caractérisé en

ce que la partie formant bord de lame (5, 9) s'étend obliquement depuis la partie formant corps de lame (3, 7) le long de cette partie formant corps de lame (3, 7), depuis l'extrémité de celle-ci éloignée des parties formant poignées (8, 12) jusqu'à une zone se situant au-delà du trou d'axe de pivotement (19, 21).

2. Dispositif de découpage suivant la revendication 1, caractérisé en ce que chaque lame (10, 14) comporte des moyens d'accrochage (23) permettant l'accrochage de la lame (10, 14) dans la matière plastique.

3. Dispositif de découpage suivant la revendication 2, caractérisé en ce que les moyens d'accrochage (23) sont constitués par au moins un trou, une fente, une encoche ou une partie saillante.

4. Dispositif de découpage suivant l'une quelconque des revendications précédentes, caractérisé en ce que la partie formant bord de lame (5, 9) s'étend au-delà de l'extrémité de la partie formant corps de lame (3, 7) éloignée des parties formant poignées (8, 12).

5. Dispositif de découpage suivant l'une quelconque des revendications précédentes, caractérisé en ce que la partie formant bord de lame (5, 9) est de section décroissante de manière à être plus épaisse à l'extrémité éloignée des parties formant poignées (8, 12).

6. Dispositif de découpage suivant l'une quelconque des revendications précédentes, caractérisé en ce qu'au moins l'une des lames (10, 14) est inclinée vers l'autre.

7. Dispositif de découpage suivant l'une quelconque des revendications précédentes, caractérisé en ce que la partie formant bord de lame (5, 9) et la partie formant corps de lame (3, 7) sont embouties au départ d'un flan en acier.

8. Dispositif de découpage suivant l'une quelconque des revendications précédentes, caractérisé en ce que la partie formant bord de lame (5, 9) est trempée.

9. Dispositif de découpage suivant la revendication 8, caractérisé en ce que la partie formant bord de lame (5, 9) est trempée par un procédé de trempe par laser ou par un procédé de trempe par induction.

50

55

60

65

5

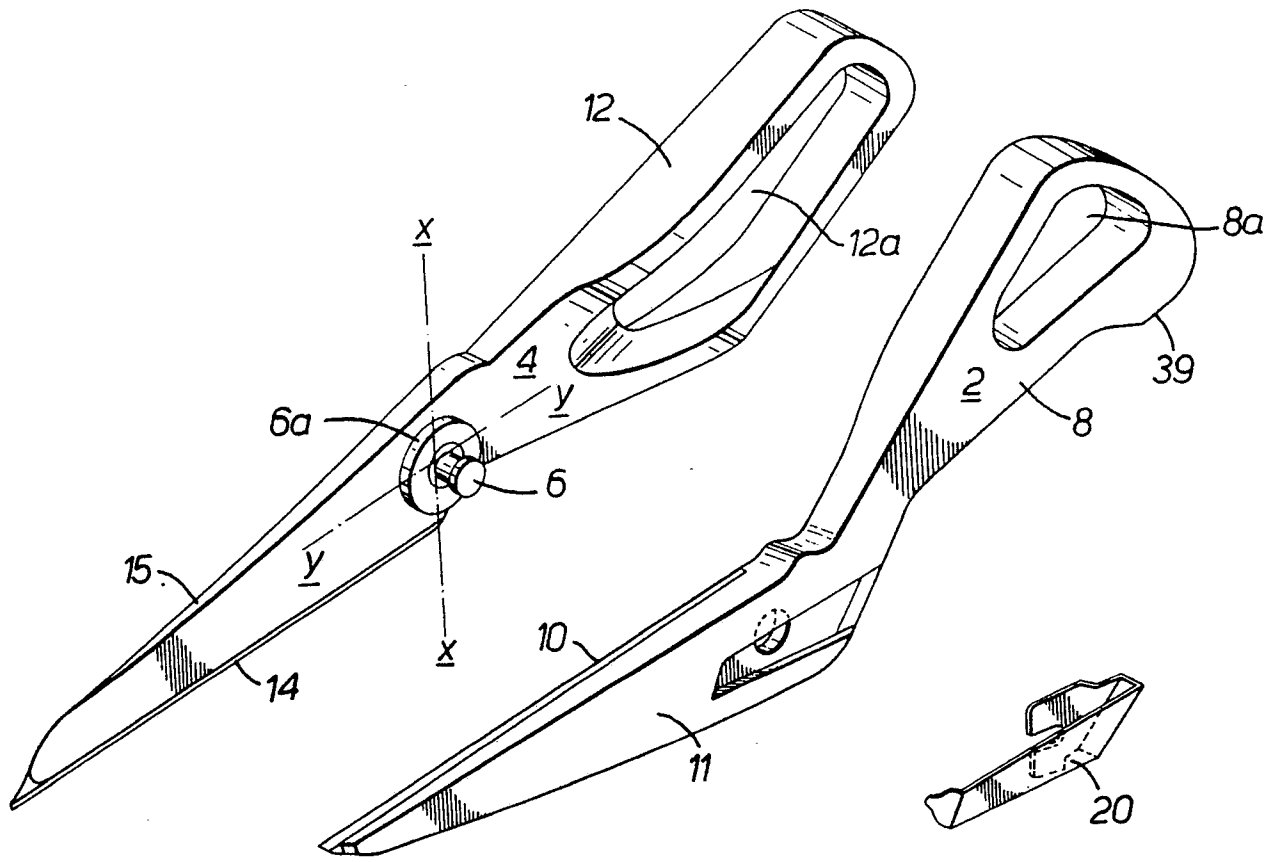

FIG. 1.

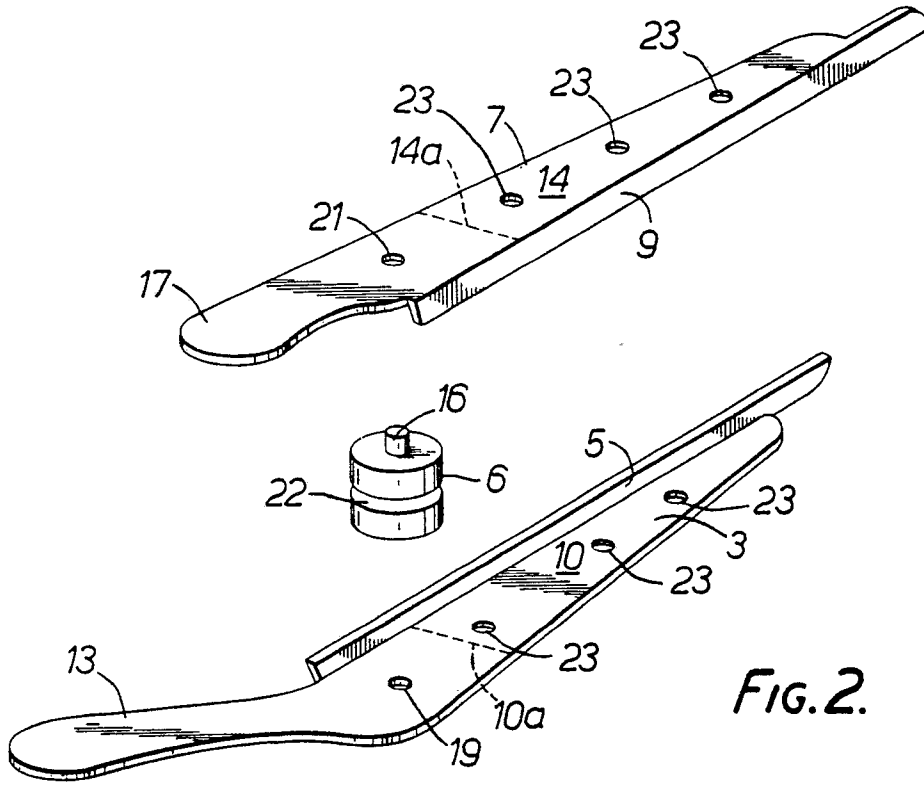

FIG. 2.

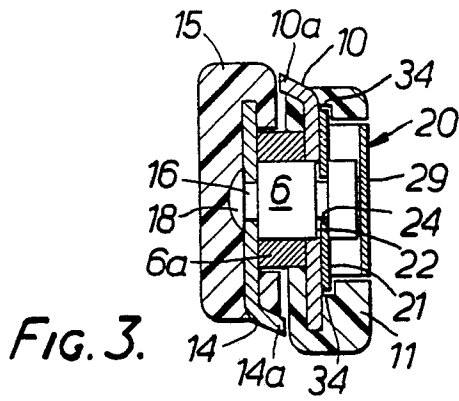

FIG. 3.

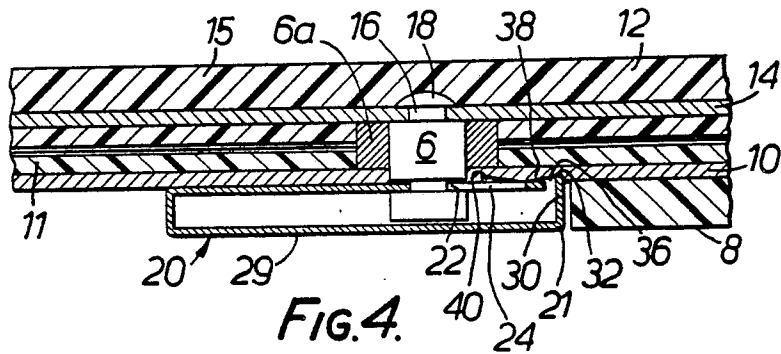

FIG. 4.

