

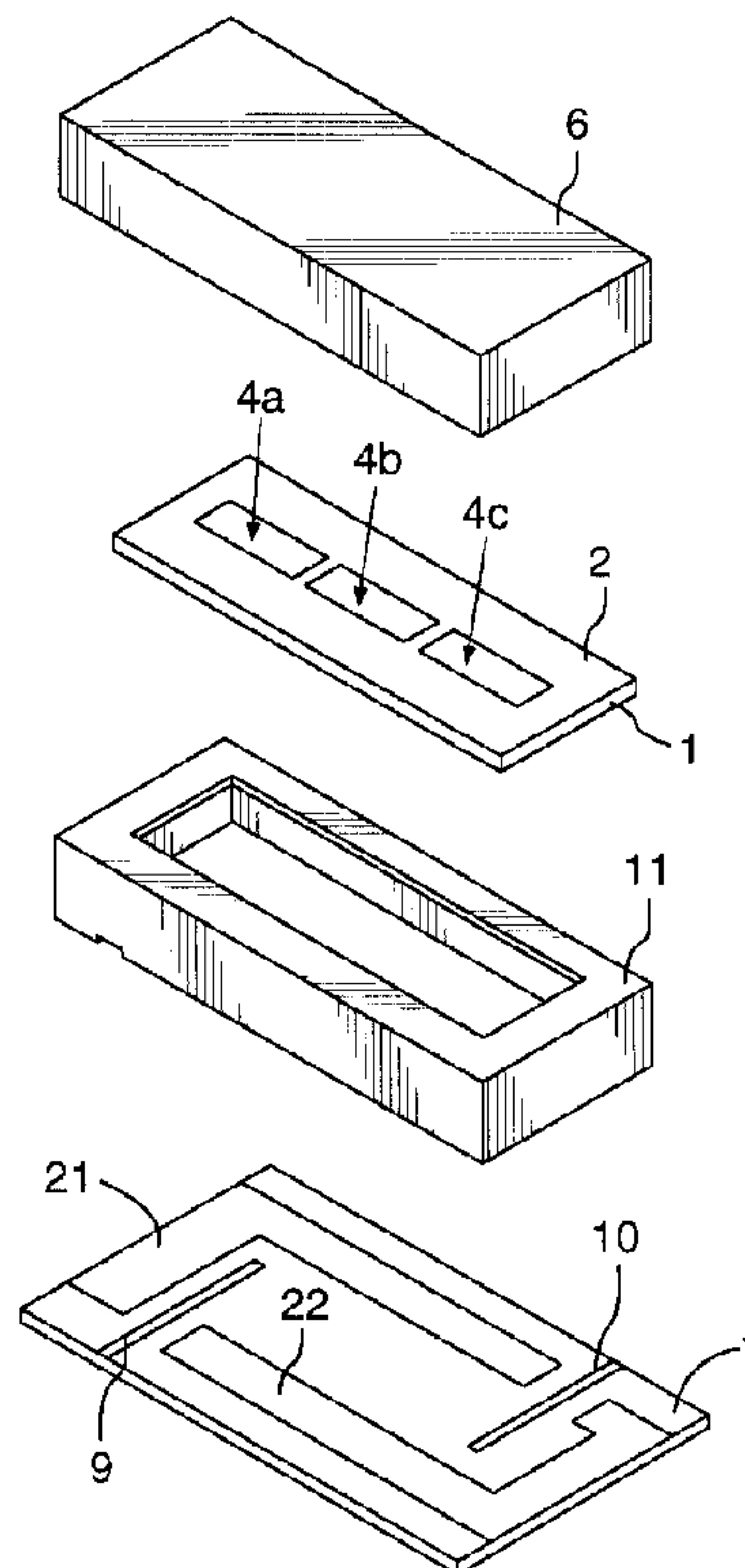

(22) Date de dépôt/Filing Date: 1999/03/30
 (41) Mise à la disp. pub./Open to Public Insp.: 1999/10/03
 (45) Date de délivrance/Issue Date: 2002/08/20
 (30) Priorités/Priorities: 1998/04/03 (10-91986) JP;
 1999/03/09 (11-062217) JP

(51) Cl.Int.⁶/Int.Cl.⁶ H01P 7/10
 (72) Inventeurs/Inventors:
 MIKAMI, Shigeyuki, JP;
 HIRATSUKA, Toshiro, JP;
 SONODA, Tomiya, JP
 (73) Propriétaire/Owner:
 MURATA MANUFACTURING CO., LTD., JP
 (74) Agent: SIM & MCBURNEY

(54) Titre : RESONATEUR DIELECTRIQUE
 (54) Title: DIELECTRIC RESONATOR DEVICE



(57) **Abrégé/Abstract:**

A dielectric resonator device is disclosed in which characteristics of a plane circuit type dielectric resonator device applicable to miniaturization is included; non-loading Q0f a resonator is increased so as to decrease insertion loss in the case of forming a band pass filter, or the like; reduce changes in filter characteristics with respect to changes in structural dimensions of the length of the resonator, the gap between the resonators, or the like; and increase freedom in adjustment of resonant frequency to enhance production efficiency. In this arrangement, on each main surface of a dielectric plate are disposed an electrode having mutually opposing openings, which serve as a rectangular-slot mode dielectric resonator; in which the length of the resonator is longer than the half-wave length in the resonant frequency used so as to resonate in a higher mode.



ABSTRACT OF THE DISCLOSURE

A dielectric resonator device is disclosed in which characteristics of a plane circuit type dielectric resonator device applicable to miniaturization is included; non-loading Q_0 of a resonator is increased so as to decrease insertion loss in the case of forming a band pass filter, or the like; reduce changes in filter characteristics with respect to changes in structural dimensions of the length of the resonator, the gap between the resonators, or the like; and increase freedom in adjustment of resonant frequency to enhance production efficiency. In this arrangement, on each main surface of a dielectric plate are disposed an electrode having mutually opposing openings, which serve as a rectangular-slot mode dielectric resonator; in which the length of the resonator is longer than the half-wave length in the resonant frequency used so as to resonate in a higher mode.

- 1 -

DIELECTRIC RESONATOR DEVICE

BACKGROUND OF THE INVENTION

1. Field of the Invention

The present invention relates to a dielectric resonator device used in a microwave band and a millimeter-wave band.

2. Description of the Related Art

Conventionally, there has been a demand for miniaturizing dielectric resonator devices such as filters, oscillators, or the like, which incorporate dielectric resonators. In response to the demand, a plane circuit type dielectric resonator device has been developed. For example, there is a "para-millimeter wave band pass filter equipped with a plane circuit type dielectric resonator", 1996, Institute of Electronics, Information and Communication Engineers General Meeting C-121, and a "plane circuit type dielectric resonator device" in Japanese Patent Application No. 9-101458.

Figs. 14 and 15 show an example of a dielectric resonator device employed in the above patent application. Fig. 14 is an exploded perspective view of the device. In this figure, electrodes having three mutually opposing pairs of rectangular openings are disposed on each of both main surfaces of a dielectric plate 1. On the upper surface of

- 2 -

an I/O substrate 7 are disposed microstrip lines 9 and 10 which are used as probes, and on substantially the entire lower surface of the same is formed a ground electrode. A single dielectric resonator device is formed by sequentially stacking a spacer 11, the dielectric plate 1, and a cover 6 on the I/O substrate 7. Figs. 15A, 15B, and 15C respectively show an electromagnetic field distribution view of three resonators formed in the dielectric plate 1. Fig. 15A is a plan view of the dielectric plate 1; Fig. 15B is a sectional view of three electrode openings 4a, 4b, and 4c; and Fig. 15C is a sectional view in the narrow side direction of the dielectric plate 1. The rectangular electrode openings 4a, 4b, and 4c having a length L and a width W , which are mutually opposed having the dielectric plate 1 therebetween are formed at given gaps g . This arrangement permits formation of a dielectric resonator with a rectangular slot mode on each of the electrode openings 4a, 4b, and 4c, leading to formation of a filter having three-step resonators in the overall structure.

The conventional type of dielectric resonator device shown in Figs. 14 and 15 is extremely miniaturized overall, since it is a plane circuit type device in which a resonator is formed in a dielectric plate. However, in the conventional type of device incorporating a dielectric resonator with a rectangular slot mode, for example, non-

- 3 -

loading Q (hereinafter referred to as Q_0) is not higher than that in a dielectric resonator with the $TE_{01\delta}$ mode, since conductor loss of electrodes formed on both main surfaces of the dielectric plate is large. This causes a problem such as increase in insertion loss when a band pass filter is formed.

In order to increase Q_0 of the resonator, it is effective to make the width of the resonator (the width W of the electrode opening) longer than the length of the same (the length L of the electrode opening). In this case, however, the resonant frequency of a mode (where the directional relationship between the width and length of the electrode opening is reversed), in which the electric field direction is orthogonal to a basic resonant mode, is close to a frequency of a basic mode, resulting in degradation of spurious characteristics.

In addition, in the conventional type of rectangular slot mode resonator, there are great changes in filter characteristics with respect to changes in structural dimensions of the length L and gap g of the resonator. This leads to decrease in production efficiency.

Furthermore, in this conventional type of device, adjustment of the resonant frequency performed by giving perturbation to the magnetic field and the electric field also decreases production efficiency, since control in

- 4 -

adjustment is difficult due to great perturbation quantity.

SUMMARY OF THE INVENTION

Accordingly, it is an object of the present invention to provide a dielectric resonator device which has characteristics of a plane circuit type dielectric resonator device applicable to miniaturization, and which further can overcome the above-mentioned problems.

To this end, the present invention provides a dielectric resonator device which includes a dielectric plate; an electrode disposed on each main surface of the slab; at least one pair of substantially-polygonal mutually opposing openings formed in the electrodes; a signal input unit for inputting signals from the outside by coupling with a resonator unit formed of the electrode opening; and a signal output unit for outputting signals to the outside by coupling with the resonator unit; in which the length L in the longer side direction of at least one of the openings is longer than the half-wave length of a basic resonant mode determined by a half-wave length in resonant frequency used so as to resonate in a higher mode of the basic resonant mode.

This structure allows the resonator unit to resonate in a higher mode of the basic resonant mode, thereby, resulting in formation of an electrical barrier with no loss between

- 5 -

gnarls of electromagnetic distributions. With the electrical barrier with no conductive loss, the entire conductive loss is decreased and Q_0 of the resonator is increased, so that insertion loss is reduced in forming a filter. Since the number of the electrical barrier formed, when a resonant degree is represented by n , is represented by $n-1$, the larger the resonant degree, the less the overall conductive loss. However, since this increases the length L of the resonator, the resonant degree n is eventually determined while considering miniaturization of the device.

Furthermore, in the rectangular-slot mode resonator, as the resonant degree becomes larger, lock-in effects of electromagnetic field energy in the inside of the resonator becomes higher, so that filter characteristic changes with respect to changes in the resonator length L and the gaps g between the resonators become smaller. As a result, the present invention can enhance production efficiency.

In addition, although the strength distribution of electromagnetic field forms only one wave in the case of a basic mode resonator, distributions of the number corresponding to the resonant degree are presented in the case of a higher mode resonator, so that perturbation effects on electric fields or magnetic fields can be differentiated according to the distribution of electromagnetic field energy. For example, the insertion

- 6 -

amount of a metallic screw in an area where electromagnetic field strength is large permits coarse adjustment of resonant frequency, whereas the insertion amount of a metallic screw in an area where electromagnetic field strength is small permits fine adjustment of resonant frequency.

BRIEF DESCRIPTION OF THE DRAWINGS

Fig. 1 is an exploded perspective view of a dielectric resonator device according to an embodiment of the present invention;

Figs. 2A, 2B, and 2C respectively show an electromagnetic field distribution view of a resonator employed in the dielectric resonator device;

Fig. 3 is a graph showing the relationship between the width of a resonator and non-loading Q regarding a basic mode resonator and a double mode resonator;

Fig. 4 is a graph showing the relationship between change rates in the length of the resonator and in the resonant frequency regarding the basic mode resonator and the double mode resonator;

Fig. 5 is a graph showing the relationship between change rates in the gap between the resonators and in the coupling coefficients regarding the basic mode resonator and the double mode resonator;

- 7 -

Fig. 6 is a graph showing the relationship between insertion amounts of a screw for adjusting resonant frequency and change rates in the resonant frequency regarding the basic mode resonator and the double mode resonator;

Figs. 7A, 7B, and 7C respectively show a plan view illustrating a structure of a dielectric plate of a dielectric resonator device according to another embodiment of the present invention;

Figs. 8A, 8B, and 8C respectively show a plan view illustrating a structure of a dielectric plate of a dielectric resonator device according to another embodiment of the present invention;

Figs. 9A, 9B, and 9C respectively show a plan view illustrating a structure of a dielectric plate of a dielectric resonator device according to another embodiment of the present invention;

Fig. 10A is an exploded perspective view of a dielectric resonator device and Fig. 10B is a plan view of a dielectric plate according to another embodiment of the present invention;

Fig. 11A is an exploded perspective view of a dielectric resonator device and Fig. 11B is a plan view of a dielectric plate according to another embodiment of the present invention;

- 8 -

Fig. 12 is an exploded perspective view illustrating a structure of an antenna-shared unit;

Fig. 13 is a block diagram illustrating a structure of a transceiver;

Fig. 14 is an exploded perspective view illustrating a structure of a conventional dielectric resonator device; and

Figs. 15A, 15B, and 15C respectively show an example view of electromagnetic distribution of a resonator employed in the conventional dielectric resonator device.

DESCRIPTION OF THE PREFERRED EMBODIMENTS

Referring now to Figs. 1 to 6, a description will be given of a structure of a dielectric resonator device according to an embodiment of the present invention.

Fig. 1 is an exploded perspective view of the dielectric resonator device. In this figure, reference numeral 1 denotes a dielectric plate; and on each main surface of the dielectric plate is formed an electrode having three mutually opposing pairs of rectangular openings. Reference numeral 7 denotes an I/O substrate, on the upper surface of which microstrip lines 9 and 10 used as probes are formed; and on substantially the entire lower surface of the substrate is formed a ground electrode. Reference numeral 11 denotes a spacer which is in a form of metallic frame. The spacer 11 is stacked on the I/O substrate 7 and

- 9 -

then the dielectric plate 1 is placed thereon so as to make a specified distance between the I/O substrate 7 and the dielectric plate 1. A cut-away part is formed at each part opposing the microstrip lines 9 and 10 of the spacer 11, so that microstrip lines 9 and 10 are not shunted. Reference numeral 6 denotes a metallic cover, which performs electromagnetic shielding in the circumference of the dielectric plate 1 when it encloses the spacer 11.

Figs. 2A, 2B and 2c respectively show a view of electromagnetic distribution of three resonator units formed on the dielectric plate 1. Fig. 2A is a plan view of the dielectric plate 1; Fig. 2B is a sectional view crossing each of the opposing three electrode openings; and Fig. 2C is a sectional view in the shorter side direction of the dielectric plate 1. Rectangular electrode openings 4a, 5a, 4b, 5b, 4c, and 5c with the length L and the width W, which are opposing through the dielectric plate 1 disposed therebetween are formed at a specified gap g. This structure allows each of the electrode openings 4a, 5a, 4b, 5b, 4c, and 5c to operate as a rectangular-slot mode dielectric resonator so as to produce magnetic coupling between the adjacent resonators. The microstrip line 9 is magnetically coupled with the resonator formed of the electrode openings 4a and 5a; and the microstrip line 10 is magnetically coupled with the resonator formed of the

- 10 -

electrode openings 4c and 5c. This arrangement permits formation of a filter comprising three-step resonators overall.

In the rectangular-slot mode dielectric resonator, the resonant frequency is determined by the resonator length L , the resonator width W , and the thickness and dielectric constant of the dielectric plate 1. In this figure, the resonator length L is equivalent to substantially twice the resonator length of a basic resonant mode resonator, namely, equivalent to a wavelength in the resonant frequency used. This permits formation of a second-higher mode (hereinafter referred to as "double mode") resonator, as shown in Figs. 2A and 2B, thereby leading to occurrence of an electrical barrier at a center of the resonator length L . A solid line with an arrow in Fig. 2A indicates an electrodynamic line; and a broken line in Fig. 2B indicates a magnetic line. The electromagnetic field is distributed as indicated here; in which although current flows to the shorter side part of the periphery of the electrode opening and conductor loss is generated at the part, there is no conductor present at the central electrical barrier, so that no conductor loss is generated at this part. Thus, the entire conductor loss is decreased so as to produce a dielectric resonator with high Q_0 .

Moreover, since lock-in effects of electromagnetic

- 11 -

field energy in the higher-mode resonator is greater than that in a basic mode resonator, changes in filter characteristics with respect to changes in the resonator length L and in the gap g between the resonators in the higher-mode resonator is smaller than those in the basic mode resonator. Thus, stable filter characteristics can be obtained regardless of the dimensional accuracy of electrodes 2 and 3, to some extent.

In Fig. 2B, there are shown 24a, 25a, 24b, 25b, 24c, and 25c as respective screws for adjusting resonant frequency of the resonators; in which 24a, 24b, and 24c are respectively positioned at the electrical barrier generated at the center of the resonator length L . The screws 25a, 25b, and 25c are respectively positioned near the top end of the resonator length L . Since the screws 24a, 24b, and 24c for adjusting resonant frequency of the resonators are positioned in an area where magnetic field energy density is high, the screw insertion amount greatly perturbs the magnetic field of each resonator so as to allow coarse adjustment of resonant frequency. In addition, the screws 25a, 25b, and 25c are respectively positioned in an area where magnetic field energy density is low, the screw insertion amount slightly perturbs the magnetic field of each resonator so as to perform fine adjustment of resonant frequency. In this way, a combination of coarse adjustment

- 12 -

and fine adjustment permits a coarse and fine adjustment of resonant frequency of the resonator, resulting in enhancement of production efficiency.

Fig. 3 shows non-loading ratio Q with respect to some resonator widths W regarding a basic resonant mode (hereinafter simply referred to as a "basic mode") resonator and a double mode resonator. As seen here, high non-loading ratio Q can be obtained regardless of the resonator widths W . When this resonator is used in a band pass filter with center frequency of 40 GHz and fractional bandwidth of 2%, insertion loss in the case of the double mode is about 20% improved over that of the basic mode.

Fig. 4 shows change rates of resonant frequency when the resonator length L is different regarding the basic mode resonator and the double mode resonator. Fig. 5 shows change rates of coupling coefficients with respect to change rates of the gap g between the resonators. These results clearly show that, comparing the double mode resonator with the basic mode resonator, changes in resonant frequency with respect to changes in the resonant length L , and changes in coupling coefficients with respect to changes of the gap g between the resonators are smaller in the double mode resonator than in the basic mode resonator.

Fig. 6 shows the relationship between change rates of resonant frequency and insertion amounts of screws for

- 13 -

adjusting resonant frequency regarding the basic mode resonator and the double mode resonator. In the basic mode resonator, there is shown a case in which the screw for adjusting resonant frequency is inserted at the center of the resonator. As shown in this figure, in the double mode resonator, change rates in resonant frequency with respect to insertion amounts of the screw for adjusting resonant frequency, which is inserted into the center, are large; in contrast, change rates in resonant frequency with respect to insertion amounts of the screw for adjusting resonant frequency, which is inserted near the edge of the resonator are small.

Figs. 7A, 7B, and 7C respectively show an example in which the form of an electrode opening disposed on the dielectric plate is different. They respectively show a plan view of the dielectric plate, in which resonators with different widths are positioned together. The resonator length L and the resonator widths $W1$ and $W2$ may be determined according to characteristics necessary for each resonator. More specifically, as shown in Fig. 7B, expanding the resonator width $W1$ of a first-step resonator and a third-step resonator coupled with probes permits the resonators to be coupled with the probes more securely, despite the fact that they are double-mode resonators with higher energy-lock-in effects.

- 14 -

Figs. 8A, 8B, and 8c respectively show an example in which a plurality of resonators having different widths are disposed together. The lengths L_1 and L_2 of each-step resonator may be determined according to characteristics required for each resonator. More specifically, as shown in Figs. 8A and 8C, when a first-step resonator or a third-step resonator coupled with the probes is a resonator in which the resonator length L_1 is set to substantially half-wave length in resonant frequency used, namely, a basic mode resonator, this facilitates coupling between the resonator and the probe, thereby, facilitating its coupling with an external circuit. In other words, a basic resonant mode offers lower lock-in effect of electromagnetic fields than a higher resonant mode does, so that a specified coupling degree can be obtained even though the dielectric plate is positioned away from the probe at some distance.

Figs. 9A, 9B, and 9C respectively show an example in which resonators with different widths and lengths are disposed together. Similarly, the lengths L_1 and L_2 and the widths W_1 and W_2 may be determined according to characteristics required for each resonator, degrees of coupling between the resonator and the probe, etc.

Although the embodiments described above adopt a rectangular form for the electrode opening, other forms for the electrode opening are shown in Figs. 10 and 11.

- 15 -

Figs. 10A and 11A respectively show an exploded perspective view of a dielectric resonator device; and Figs. 10B and 11B respectively show a plan view of a dielectric plate employed in the device. In Figs. 10A and 10B, electrode openings 4a, 4b, and 4c are in a polygonal form in which the four corners of a rectangular form are cut off. In Figs. 11A and 11B, electrode openings 4a, 4b, and 4c are in a form in which the four corners of a rectangular form has roundness (R form). Other arrangements are the same as those shown in Fig. 1, and Figs. 2A and 2B.

Such arrangements regarding forms of electrode openings shown in Figs. 10A and 10B, and Figs. 11A and 11B permit alleviation of current concentration at the four corners, leading to improvement in Q0. In addition, filter attenuation characteristics can also be improved, since degrees of detuning between a main mode and a spurious mode can be controlled by the manner in which the corners are cut off or the manner in which they are rounded off.

Although the example shown in Figs. 10A and 10B adopts an octagonal form obtained by simply cutting off the four corners of the rectangular electrode opening, other polygonal forms may be applicable. The electrode opening having R-formed corners as shown in Fig. 11B is also included in the connotation of "substantially polygonal" described in the present invention.

- 16 -

Fig. 12 shows an example in which the transmission/reception-shared device of the present invention is used as an antenna-shared device. In this figure, reference numeral 1 denotes a dielectric plate; on each main surface of the plate are disposed electrodes having ten mutually opposing pairs of rectangular openings. There are shown 41a to 41e and 42a to 42e as electrode openings on the upper surface. Reference numeral 7 denotes an I/O substrate; on the top surface of which microstrip lines 9, 10, and 12 used as probes are formed; and a ground electrode is formed on the substantially entire lower surface of the substrate 7. Reference numeral 11 denotes a spacer in a metallic framed form. The spacer 11 is stacked on the I/O substrate 7 to stack the dielectric plate 1 thereon, so as to be arranged between the I/O substrate 7 and the dielectric plate 1 at a specified distance. A cut-away part is formed at each part opposing the microstrip lines 9 and 10 of the spacer 11, so that microstrip lines 9 and 10 are not shunted. Reference numeral 6 denotes a metallic cover, which performs electromagnetic shielding in the circumference of the dielectric plate 1 when it encloses the spacer 11.

In Fig. 12, there are provided five dielectric resonators formed of the electrode openings 41a to 41e formed on the top surface of the dielectric plate 1 and the

- 17 -

opposing electrode openings on the lower surface of the same, in which sequential coupling between the mutually- adjacent dielectric resonators permits formation of a receiving filter having band pass characteristics made from the five-step resonators. Similar, there are provided another five dielectric resonators formed of the electrode openings 42a to 42e on the upper surface of the plate and the opposing electrode openings on the lower surface of the same, and these five dielectric resonators form a transmitting filter having band pass characteristics made from the five-step resonators.

The top end of the microstrip line 9 of the I/O substrate 7 is used as a receiving signal output port (Rx port) for the receiving filter, whereas the top end of the microstrip line 10 is used as a transmitting signal input port (Tx port) for the transmitting filter. The microstrip line 12 comprises a branch circuit and the top end of the line is used as an antenna port. The branch circuit performs branching between a transmitting signal and a receiving signal in such a manner that the electrical length between a branching point and an equivalently-shunted surface of the receiving filter is an odd multiple of one-fourth the wavelength of transmitting frequency; and the electrical length between a branching point and an equivalently-shunted surface of the transmitting filter is

- 18 -

an odd multiple of one-fourth the wavelength of the receiving frequency.

The spacer 11 has a partition for separating the receiving filter from the transmitting filter. On the lower surface of the cover 6 is formed another partition for separating the receiving filter from the transmitting filter, although the partition is not shown in the figure. Furthermore, at parts to which the spacer 11 is attached on the I/O substrate 7 are arranged a plurality of through-holes for electrically connecting the electrodes on both surfaces of the I/O substrate. This structure allows isolation between the receiving filter and the transmitting filter.

As shown here, even if a plurality of resonators is disposed on a single substrate, the present invention allows production of a transmission/reception shared device having reduced insertion loss.

Fig. 13 shows an embodiment of a transceiver incorporating the antenna-shared unit described above. In this figure, there are shown the receiving filter 46a and the transmitting filter 46b; in which the part indicated by reference numeral 46 comprises an antenna-shared unit. As shown in this figure, a receiving circuit 47 is connected to a receiving signal output port 46c of the antenna-shared unit 46; a transmitting circuit 48 is connected to a

- 19 -

transmitting signal input port 46d; and an antenna port 46e is connected to an antenna 49. As a result, the overall structure as a whole forms a transceiver 50.

According to this invention, since the resonator unit resonates in a higher mode of the basic resonant mode, and an electrical barrier with no loss is formed between the gnarls of the electromagnetic field distribution, there is no conductor loss due to the electrical barrier, so that the overall conductor loss can be reduced. Accordingly, in the case of forming a filter, insertion loss is reduced, since Q_0 of the resonator is higher.

In addition, since filter characteristic changes with respect to changes in the resonator length L and the gaps g between the resonators is smaller, so that a high level of dimensional accuracy in forming the electrodes is not necessarily demanded, thereby leading to enhancement of production efficiency.

Moreover, in this invention, since perturbation effects on electrical fields or magnetic fields can be differentiated corresponding to positions in which the electromagnetic energy density is distributed, giving perturbation independently to a part of a high distribution and a part of a low distribution in terms of the electromagnetic energy density permits both coarse adjustment and fine adjustment of resonant frequency.

- 20 -

In an aspect of the present invention, the formation of the rectangular electrode opening facilitates formation of patterns of the electrode opening with respect to the dielectric plate so as to obtain a resonator of a specified resonant frequency.

In another aspect of the present invention, expanding the width of the electrode opening of the resonator unit coupled with the signal input unit or the signal output unit facilitates coupling between the resonator and the signal input unit or the signal output unit, despite that the resonator being a higher mode resonator having a high energy-lock-in effect.

Furthermore, in another aspect of the present invention, making the resonator unit coupled with the signal input unit or the signal output unit a resonator unit with a basic resonant mode can facilitate coupling between the resonator and the signal input unit or the signal output unit.

Moreover, in another aspect of the present invention, adopting such an arrangement that the dielectric resonator device is used as a transmitting filter and a receiving filter; the transmitting filter is disposed between the transmitting signal input port and the I/O port; and the receiving filter is disposed between the receiving signal output port and the I/O port permits production of a transmission/reception shared device with lower insertion

- 21 -

loss.

In another aspect of present invention, adopting such an arrangement that a transmitting circuit is connected to the transmitting signal input port of the transmission/reception shared device; a receiving circuit is connected to the receiving signal output port of the transmission/reception shared device; and an antenna is connected to the I/O port of the transmission/reception shared device can provide a transceiver with high efficiency, namely, with smaller loss in a high frequency circuit.

WHAT IS CLAIMED IS:

1. A dielectric resonator device comprising:
 - a dielectric plate;
 - an electrode disposed on each main surface of the plate;
 - at least one pair of substantially-polygonal mutually-opposing openings formed in the electrode, each of said openings defining a longer side direction and a shorter side direction;
 - a signal input unit for inputting signals from the outside by coupling with a resonator formed of the electrode openings; and
 - a signal output unit for outputting signals to the outside by coupling with the resonator;
 - wherein a length L in the longer side direction of at least one of the openings is longer than a half-wave length of a basic resonant mode determined by a half-wave length in the resonant frequency used, so as to resonate in a higher mode of the basic resonant mode.
2. A dielectric resonator device according to Claim 1, wherein the openings are rectangular.
3. A dielectric resonator device according to Claim 1 wherein a plurality of the openings is disposed to form resonators, which are mutually coupled with; and pairs of

the openings with mutually different widths W are included.

4. A dielectric resonator device according to Claim 1, wherein a plurality of the openings is disposed to form resonators, which are mutually coupled; and the basic mode resonator and the higher mode resonator are disposed together.

5. A dielectric resonator device according to Claim 3, wherein the width W , in the shorter side direction of the opening that is used as the resonator coupled with one of the signal input unit and the signal output unit is wider than the width (W_2) in the shorter side direction of the opening that is used as another resonator.

6. A dielectric resonator device according to Claim 4, wherein the resonator coupled with the signal input unit or the signal output unit is the basic mode resonator.

7. A transmission/reception shared device containing the dielectric resonator device according to one of Claim 1 wherein the dielectric resonator device is used as a transmitting filter disposed between a transmitting signal input port and an I/O port and a receiving filter disposed between a receiving signal output port and the I/O port.

8. A transceiver comprising:

a transmitting circuit connected to the transmitting signal input port of the transmission/reception shared device according to Claim 7;

a receiving circuit connected to the receiving signal output port of the transmission/reception shared device; and

an antenna connected to the I/O port of the transmission/reception shared device.

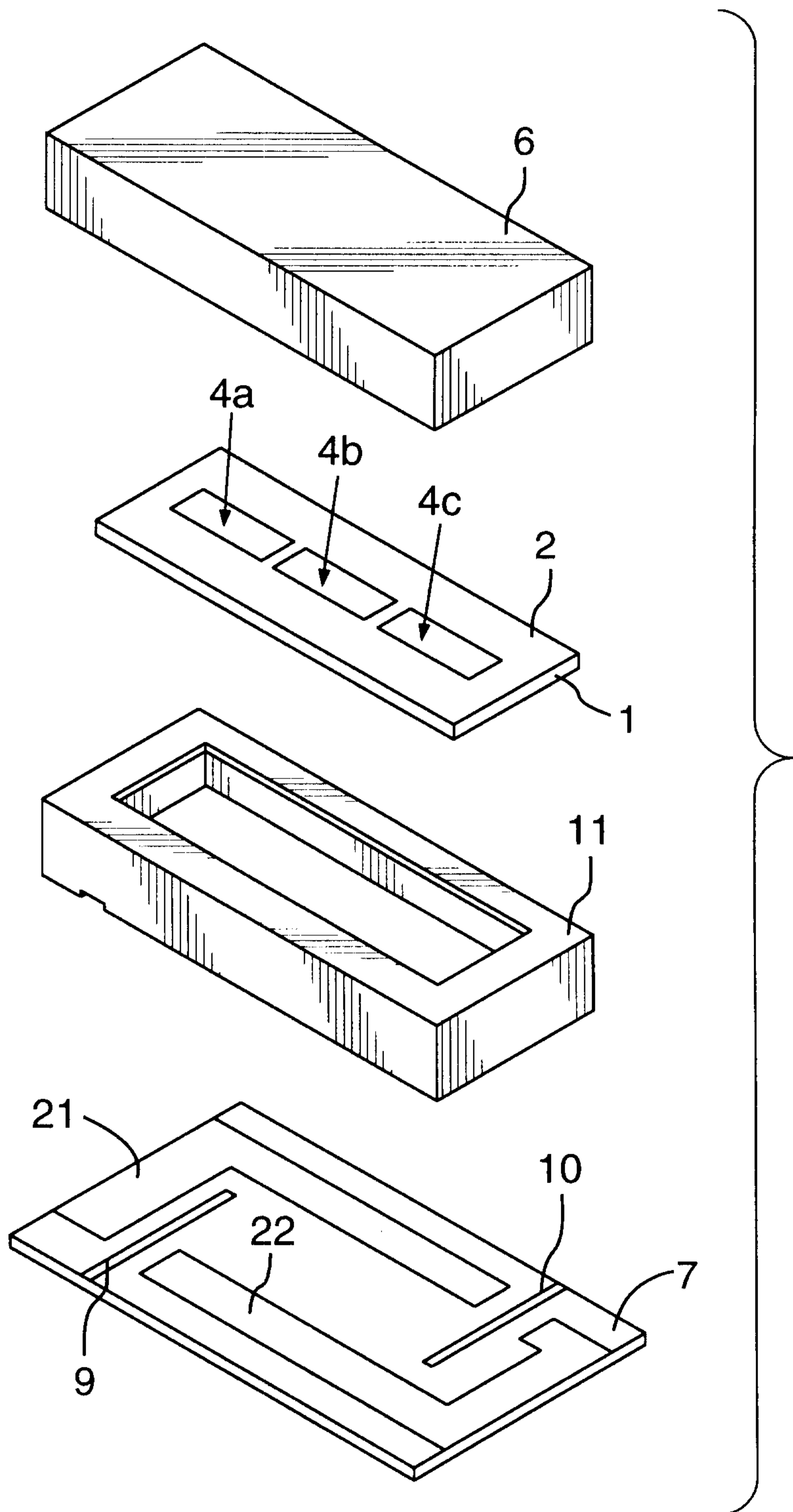

FIG.1

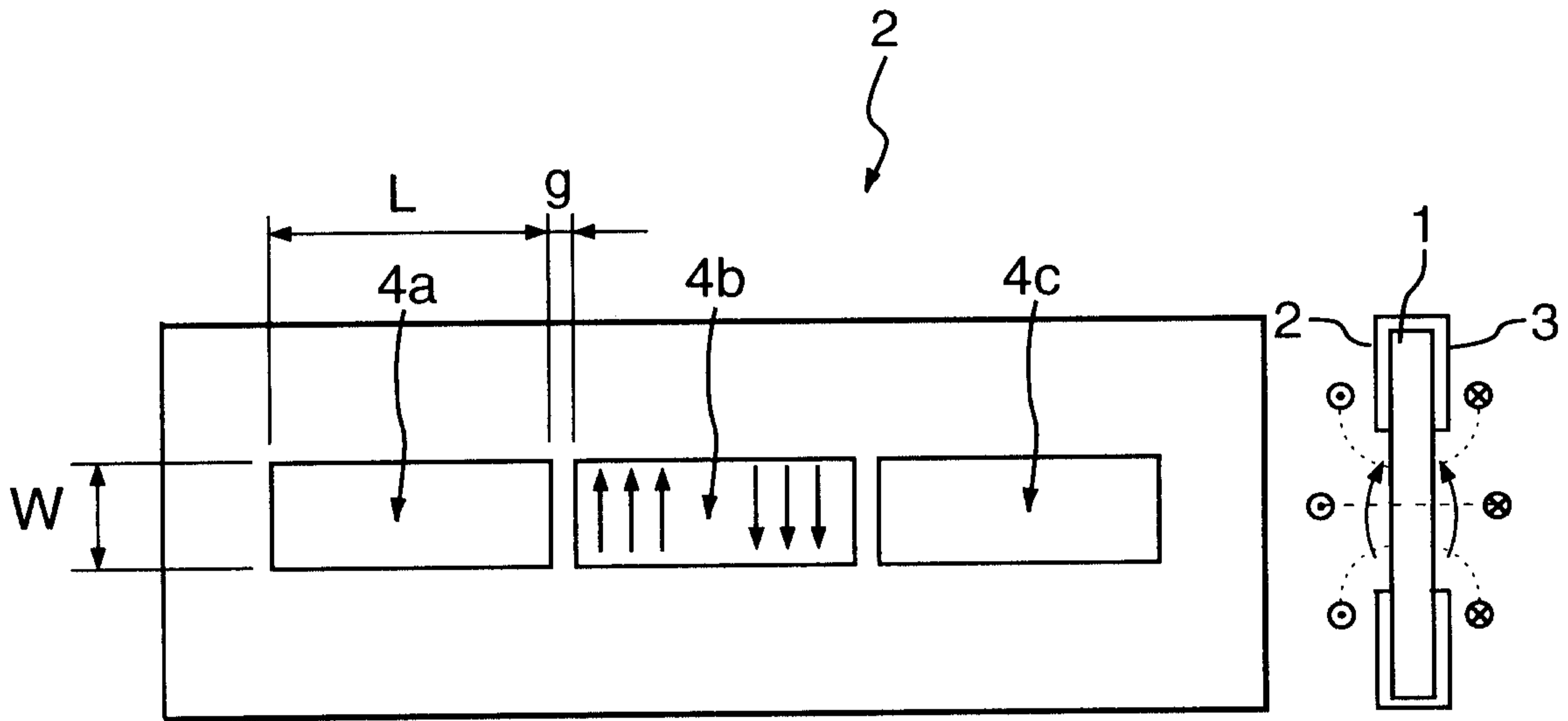

FIG.2A

FIG.2C

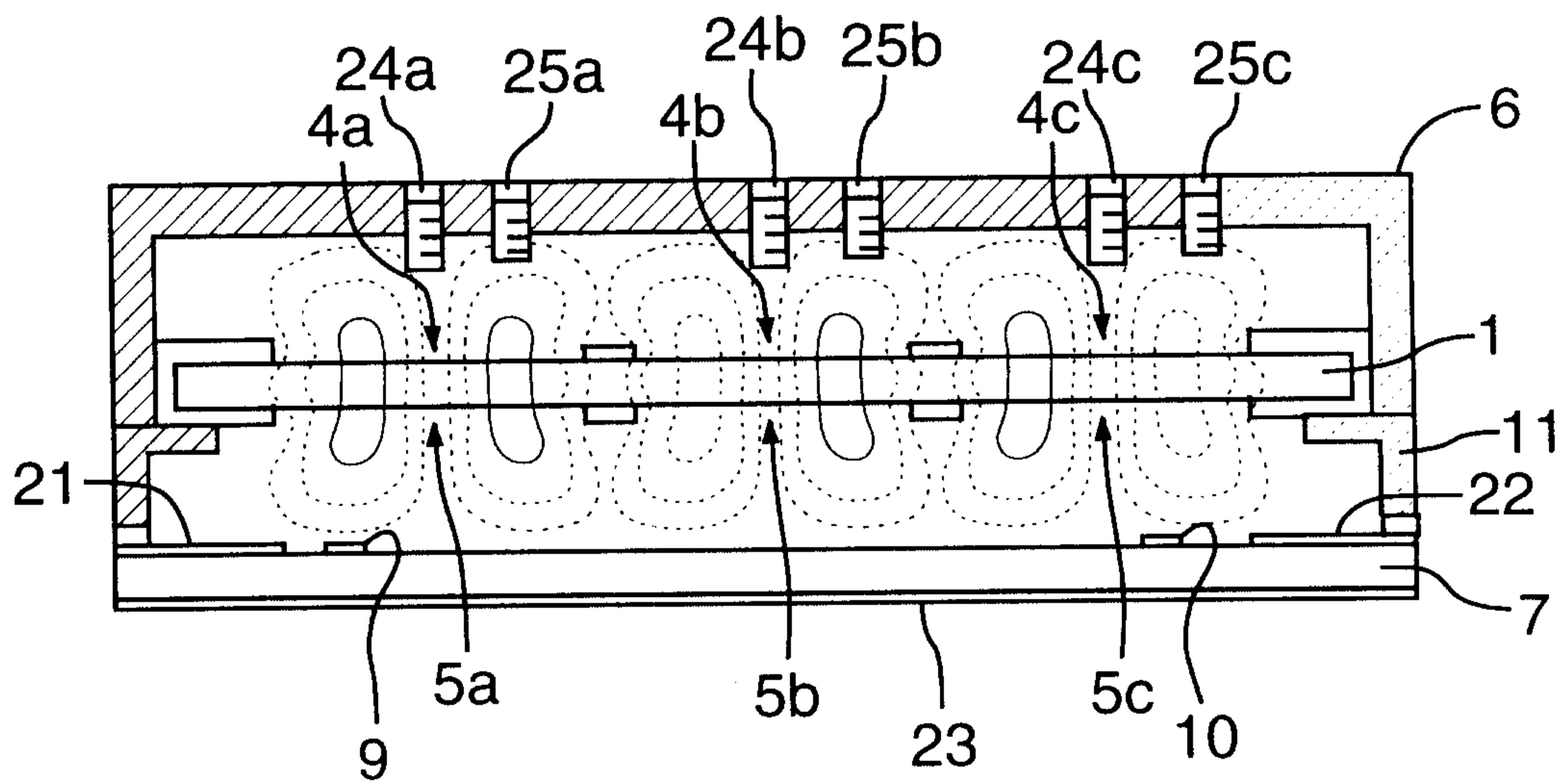

FIG.2B

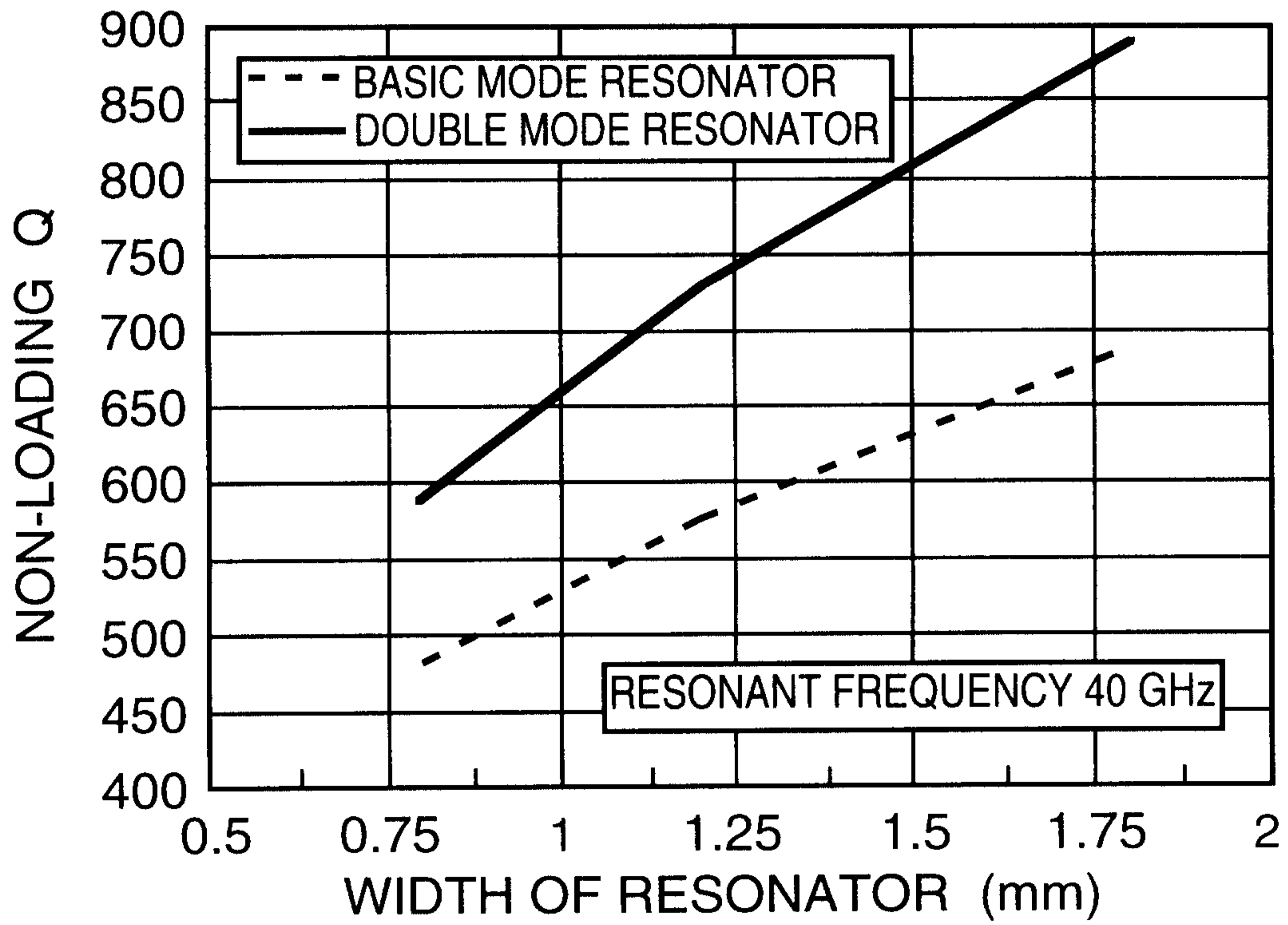

FIG.3

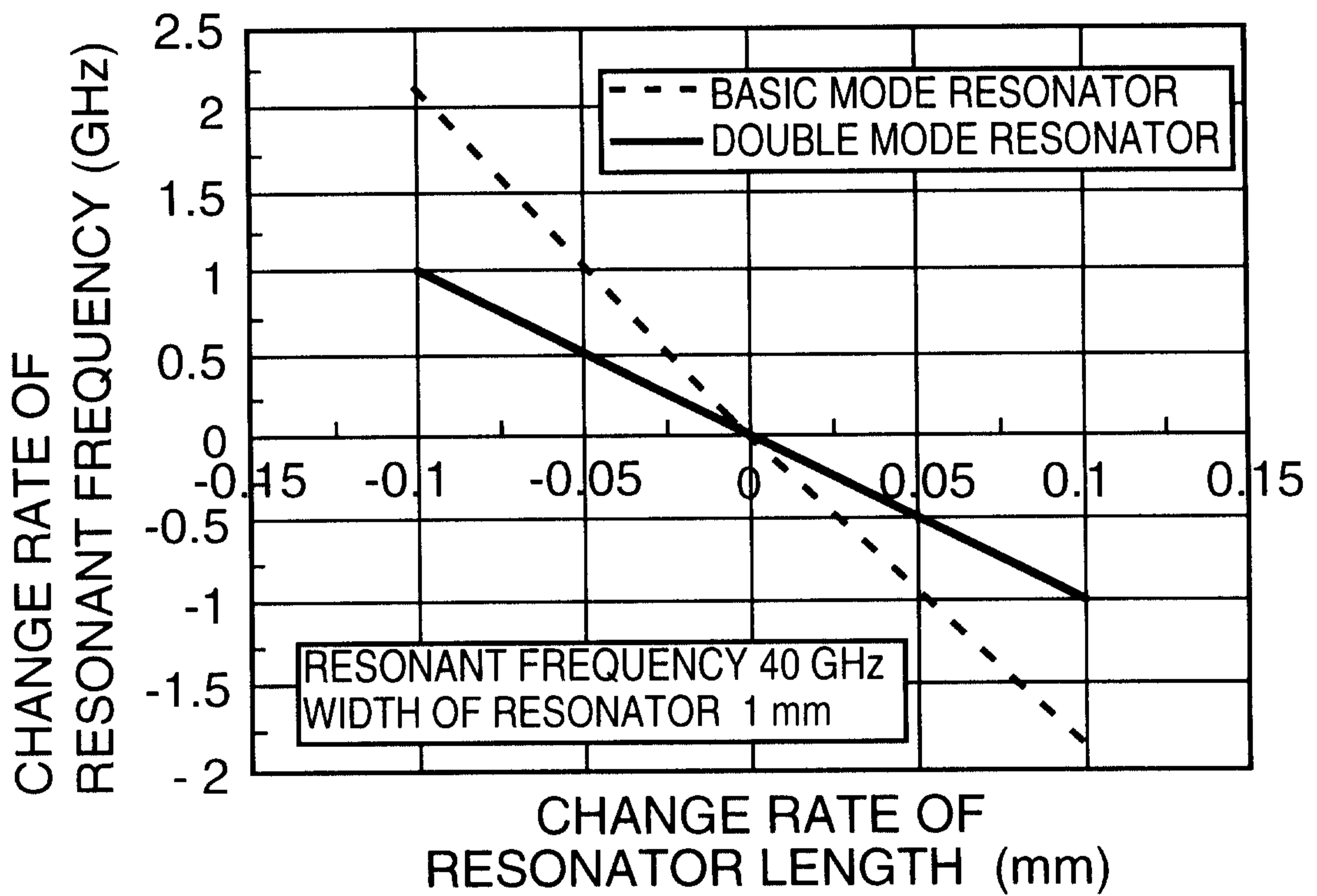

FIG.4

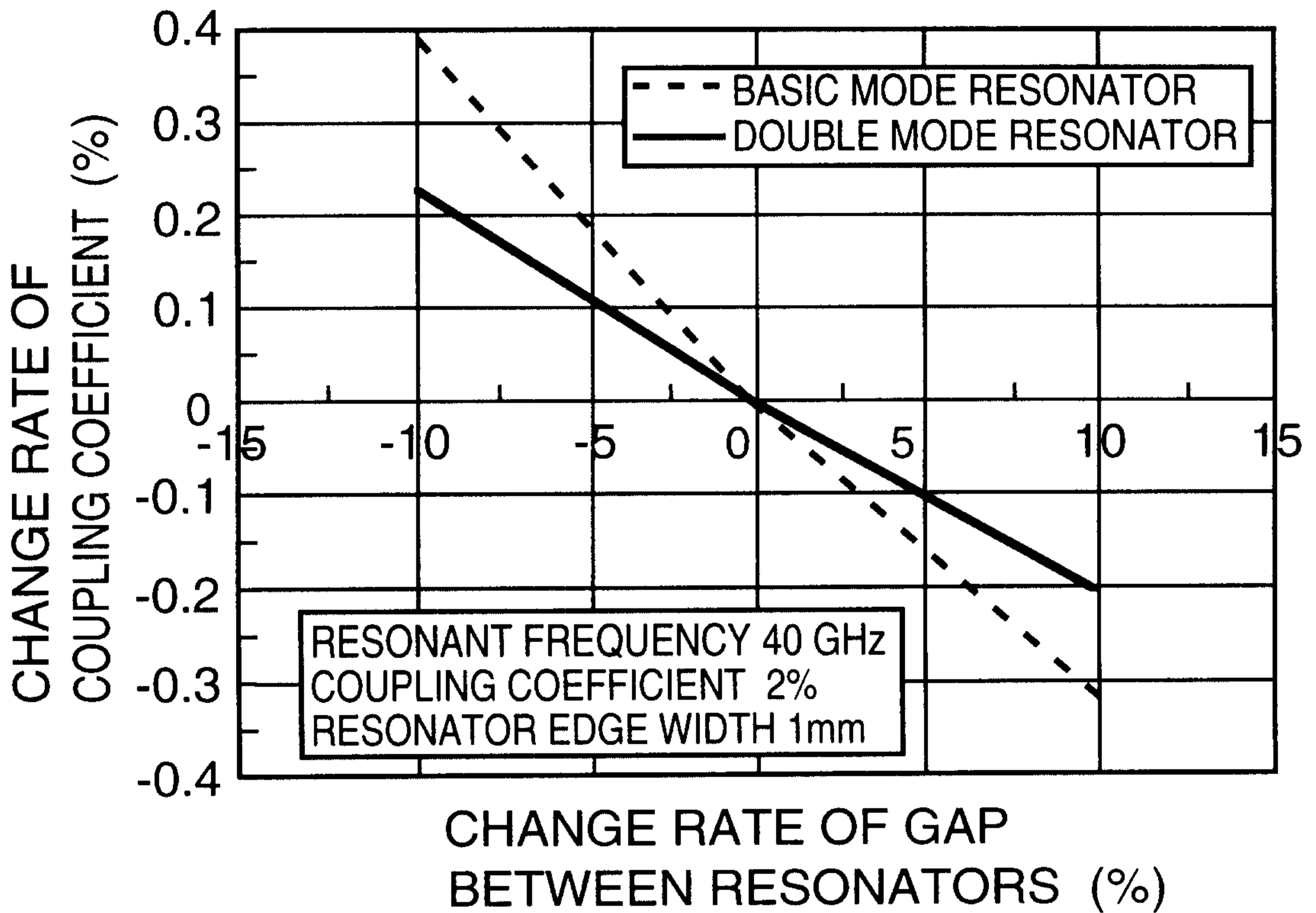

FIG.5

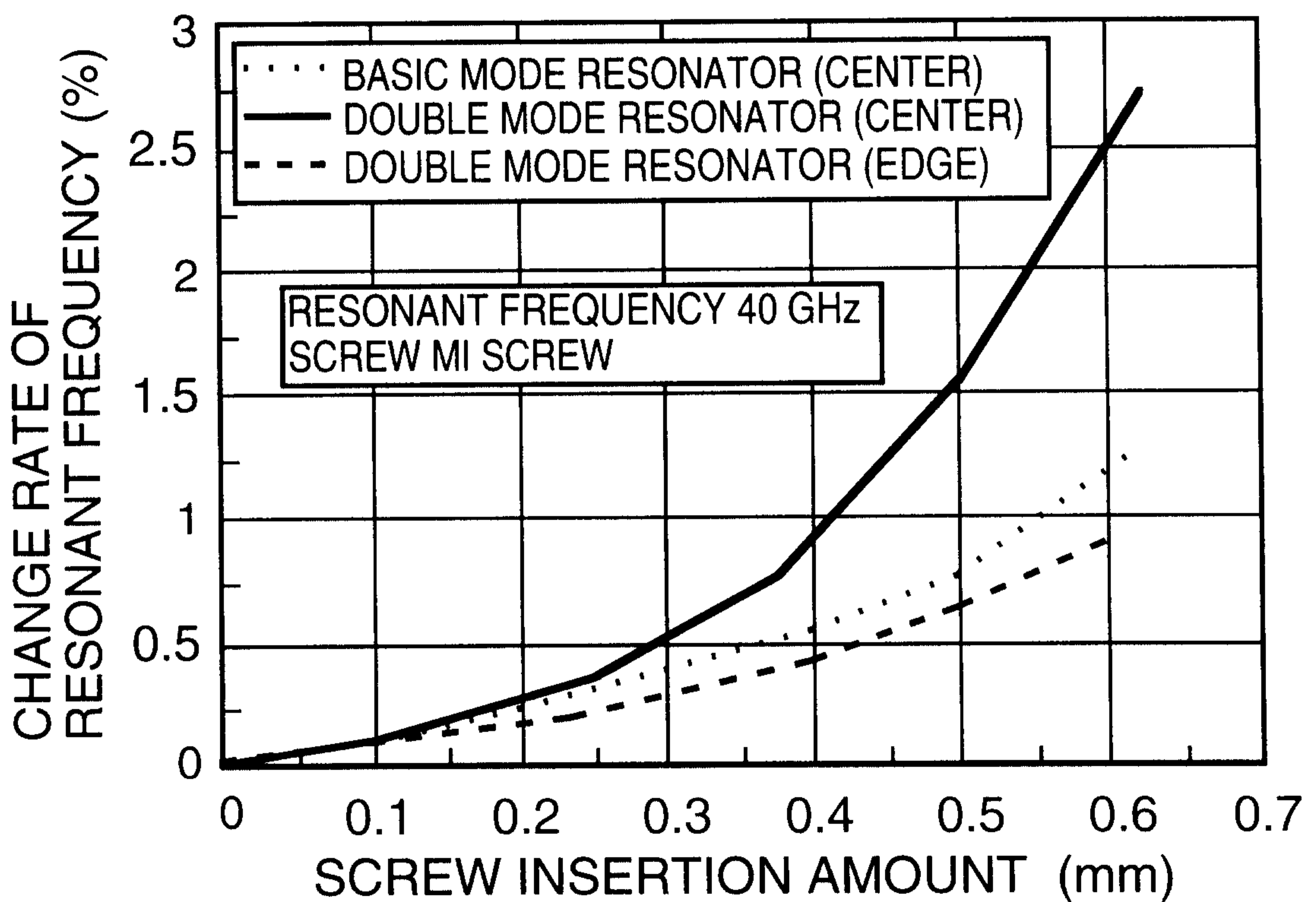

FIG.6

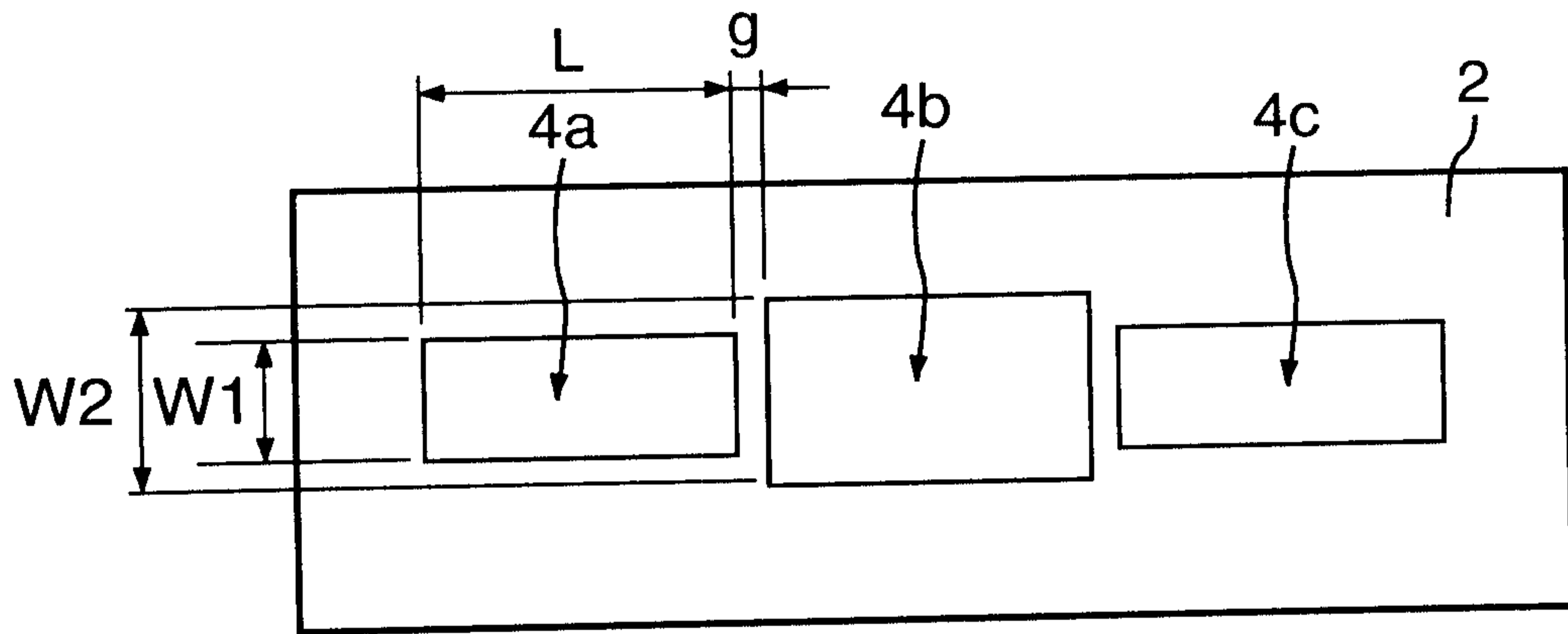

FIG. 7A

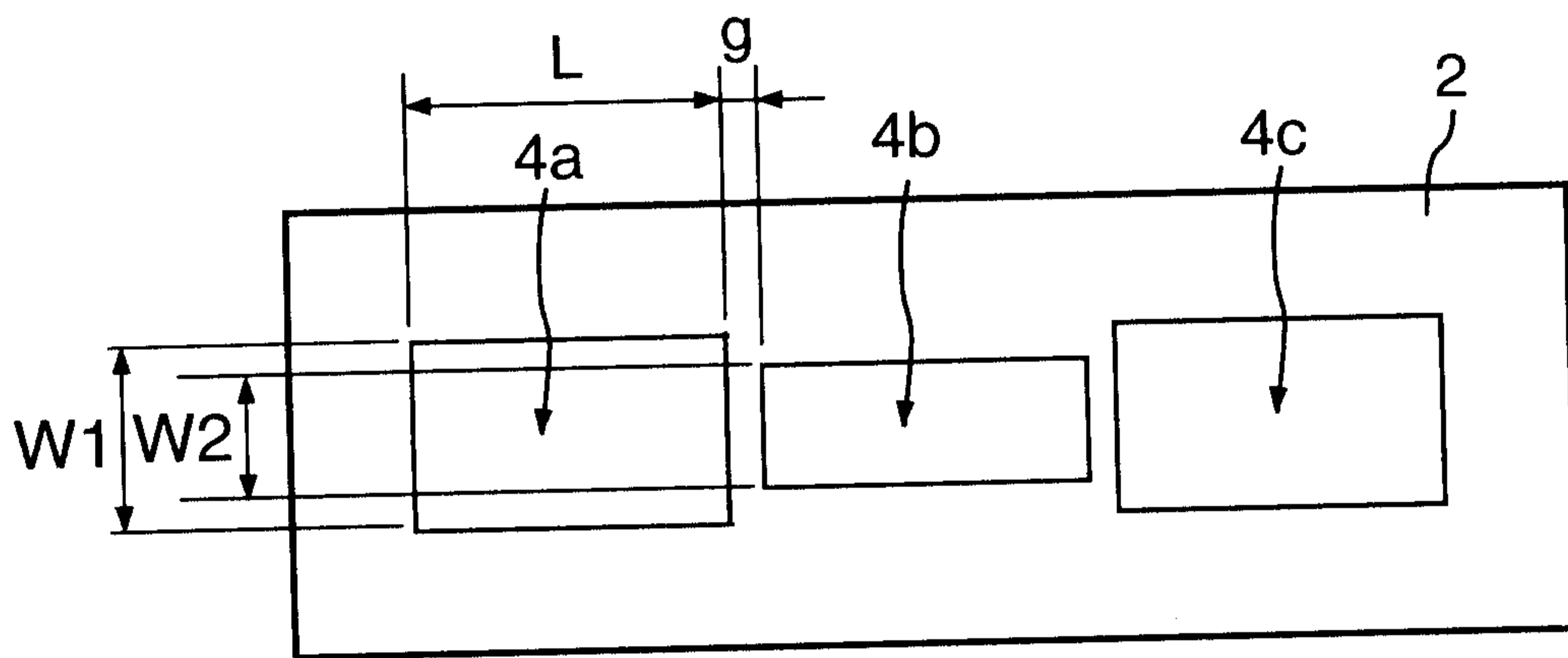

FIG. 7B

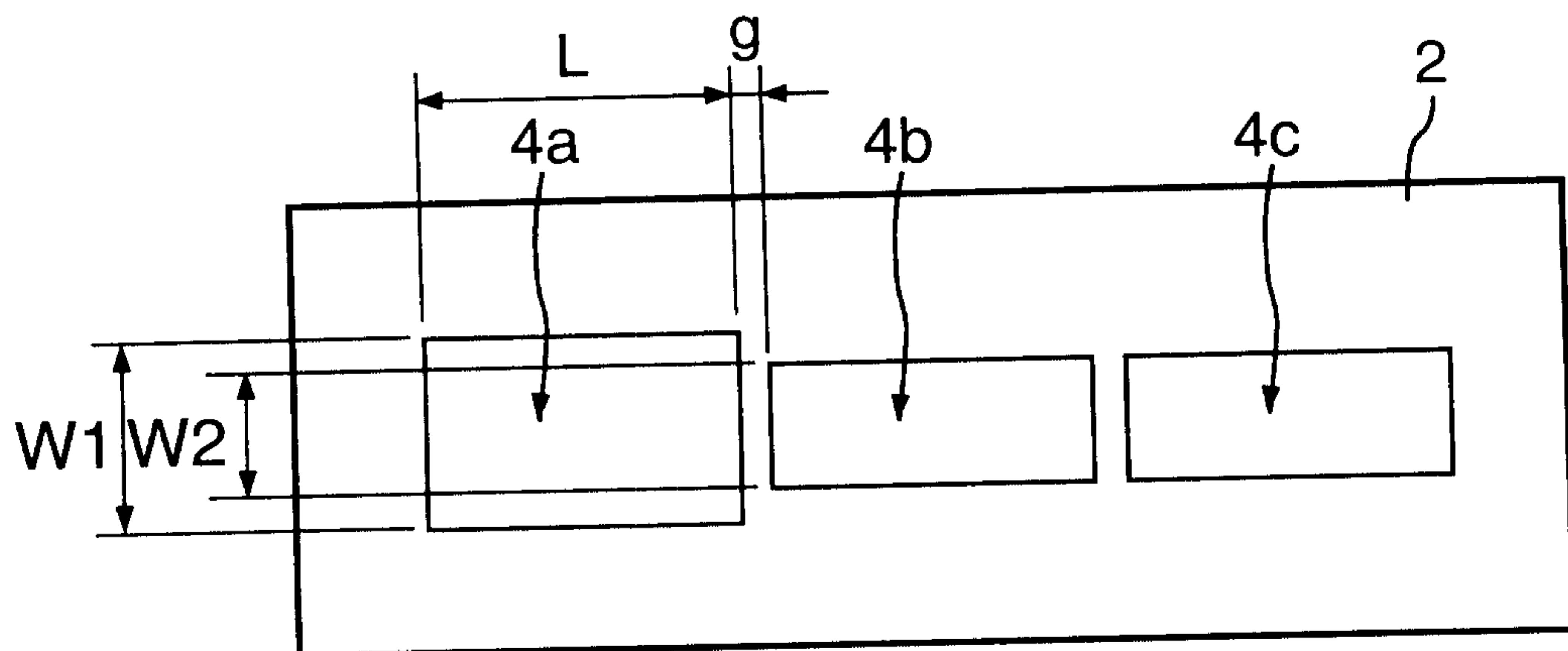

FIG. 7C

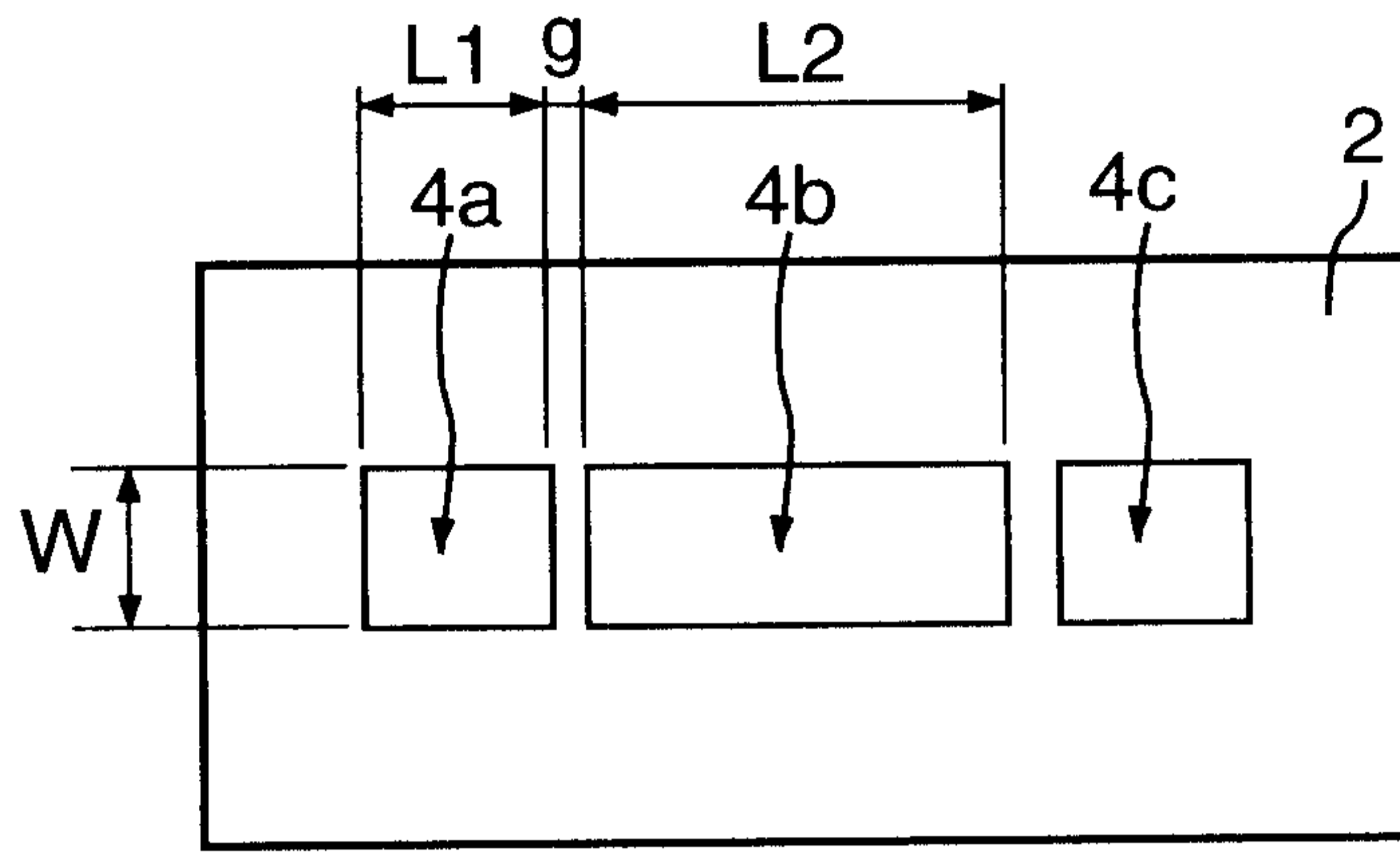

FIG. 8A

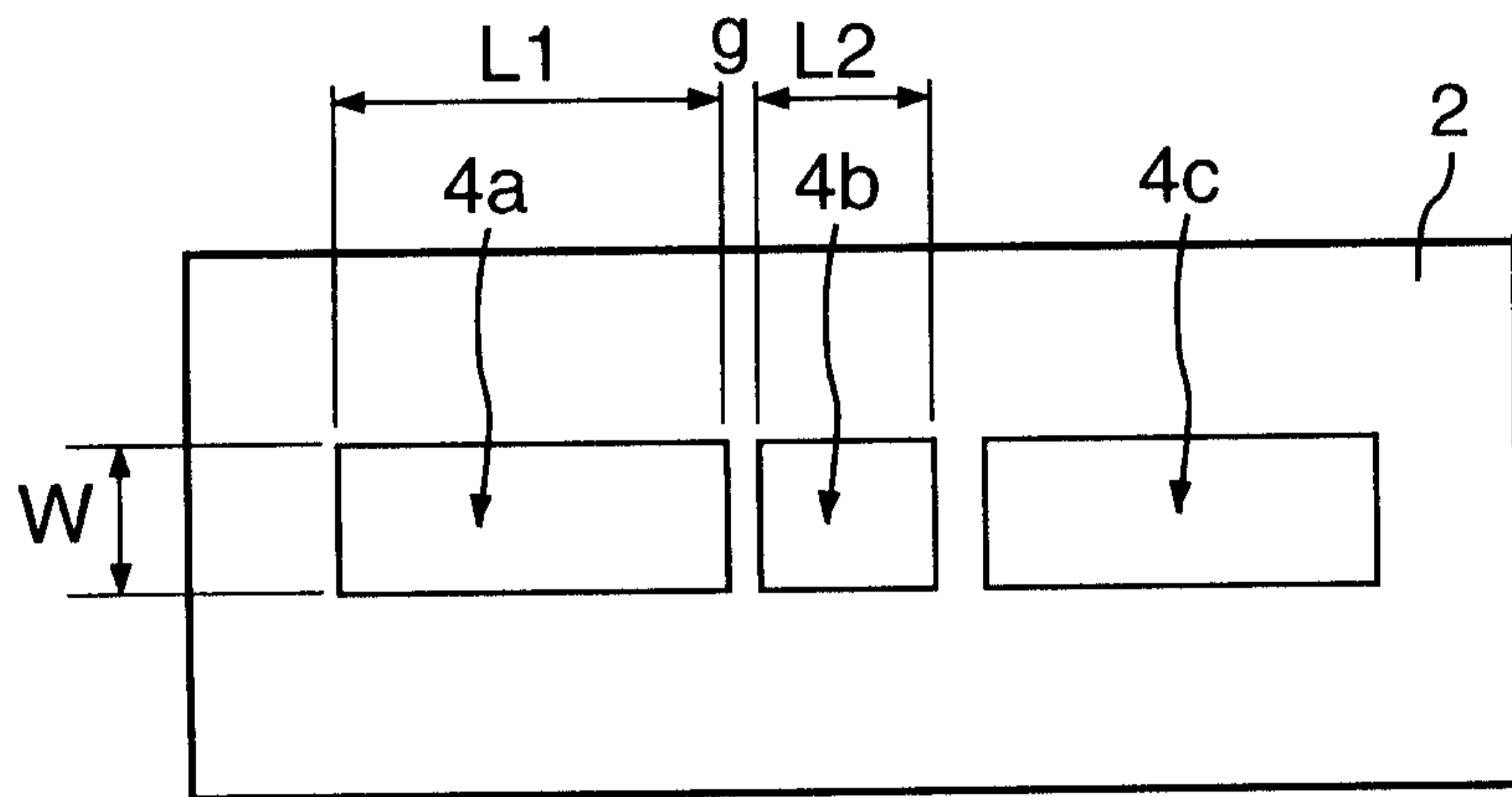

FIG. 8B

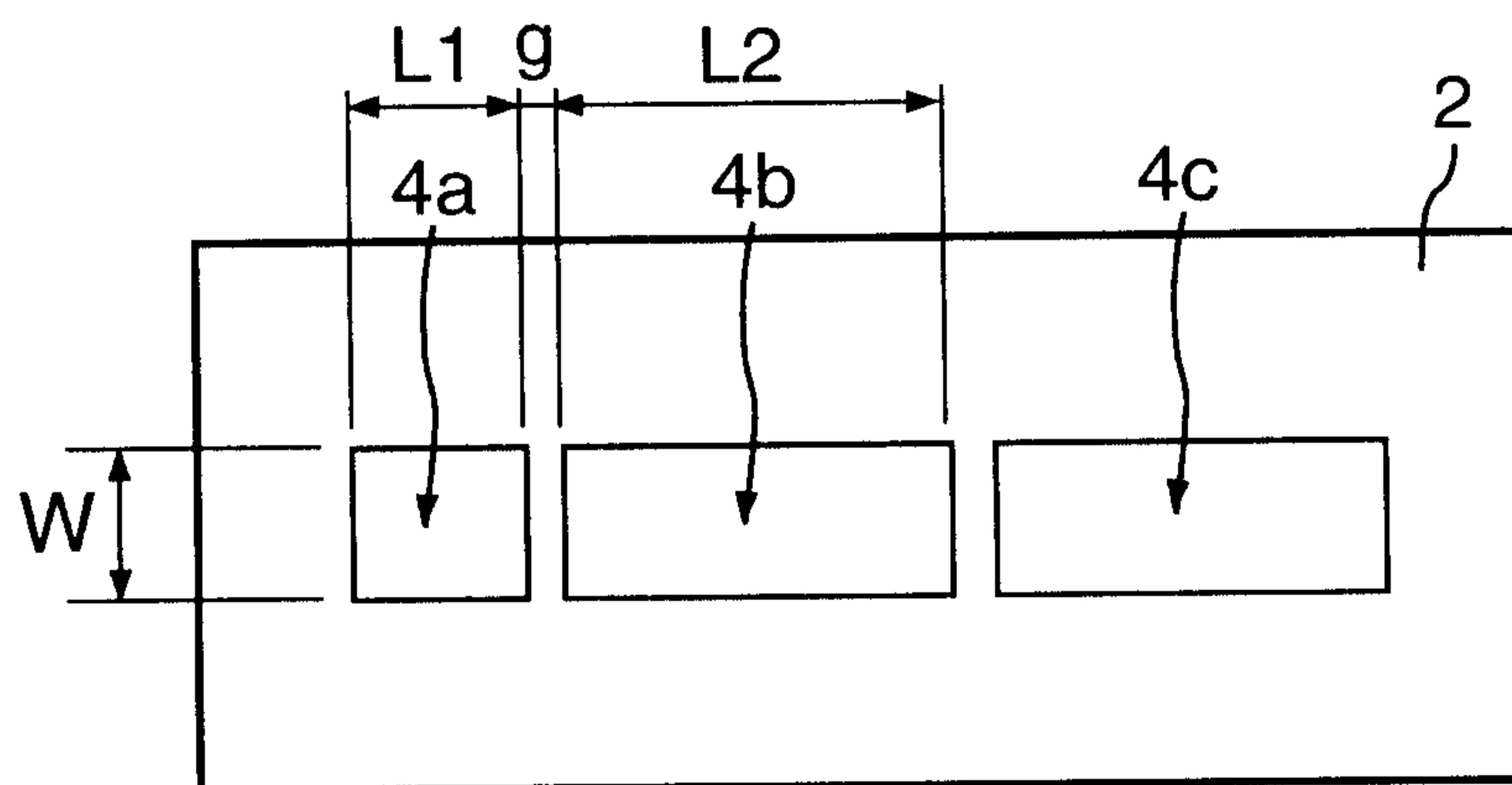

FIG. 8C

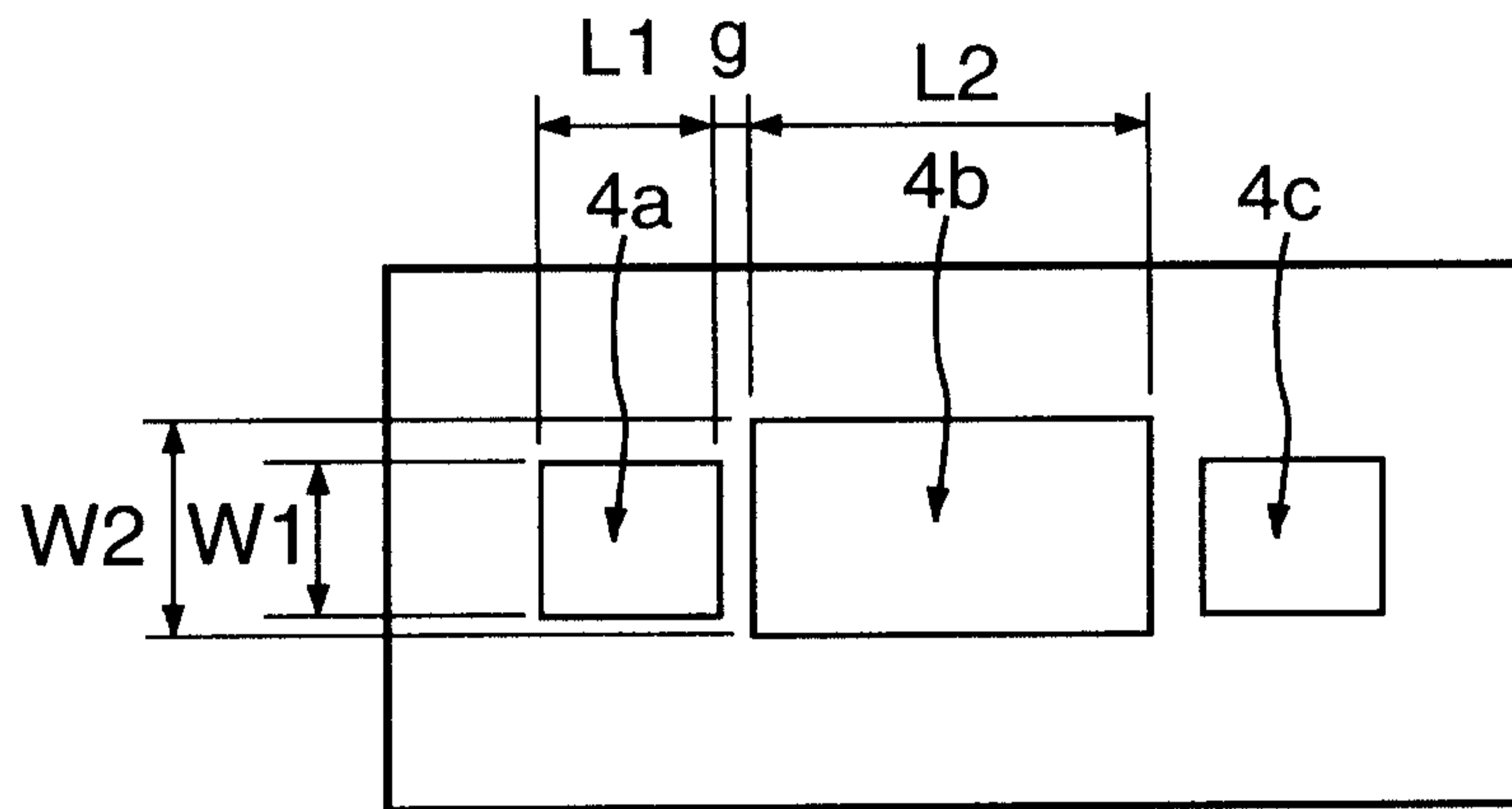

FIG. 9A

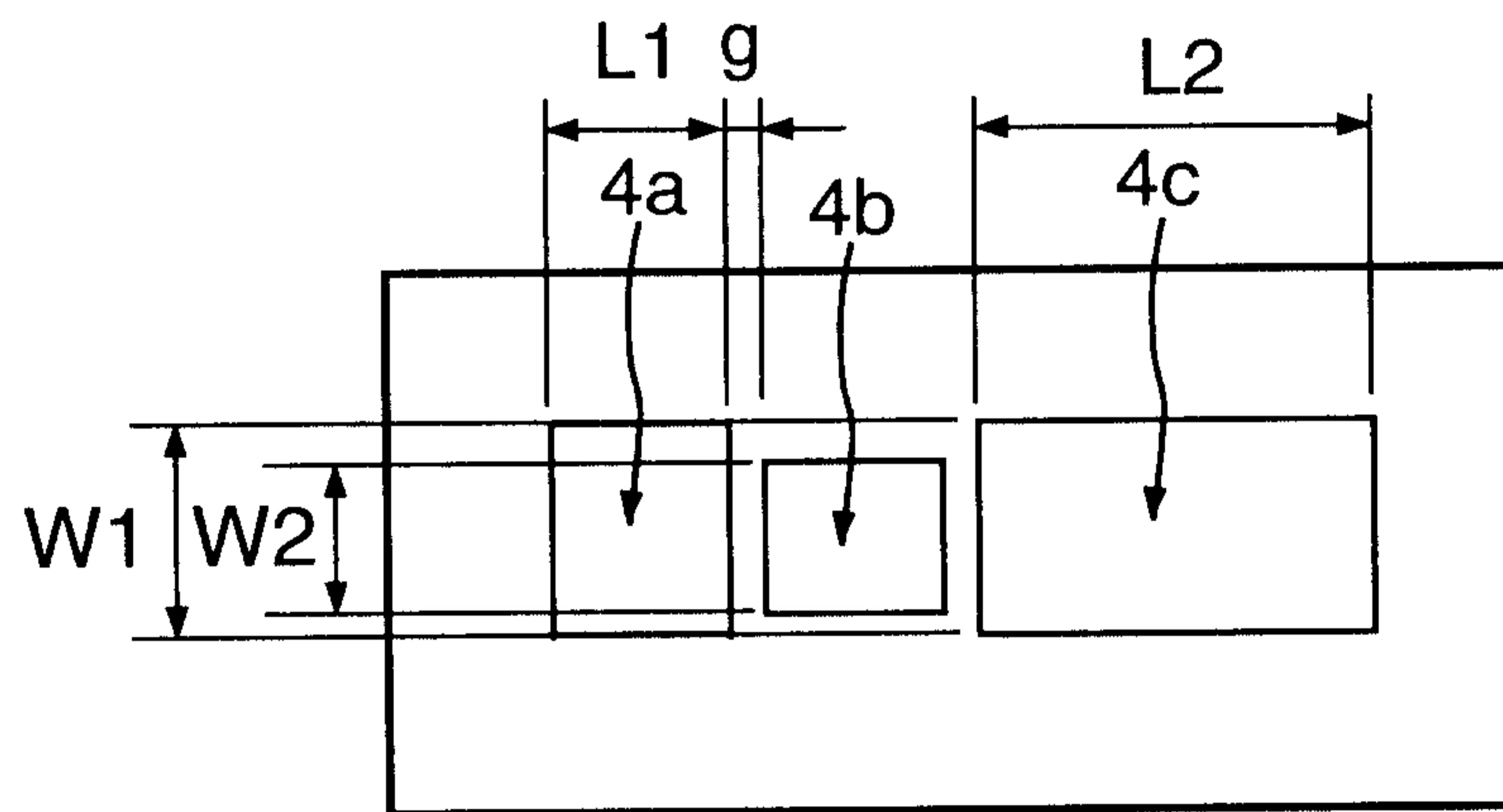

FIG. 9B

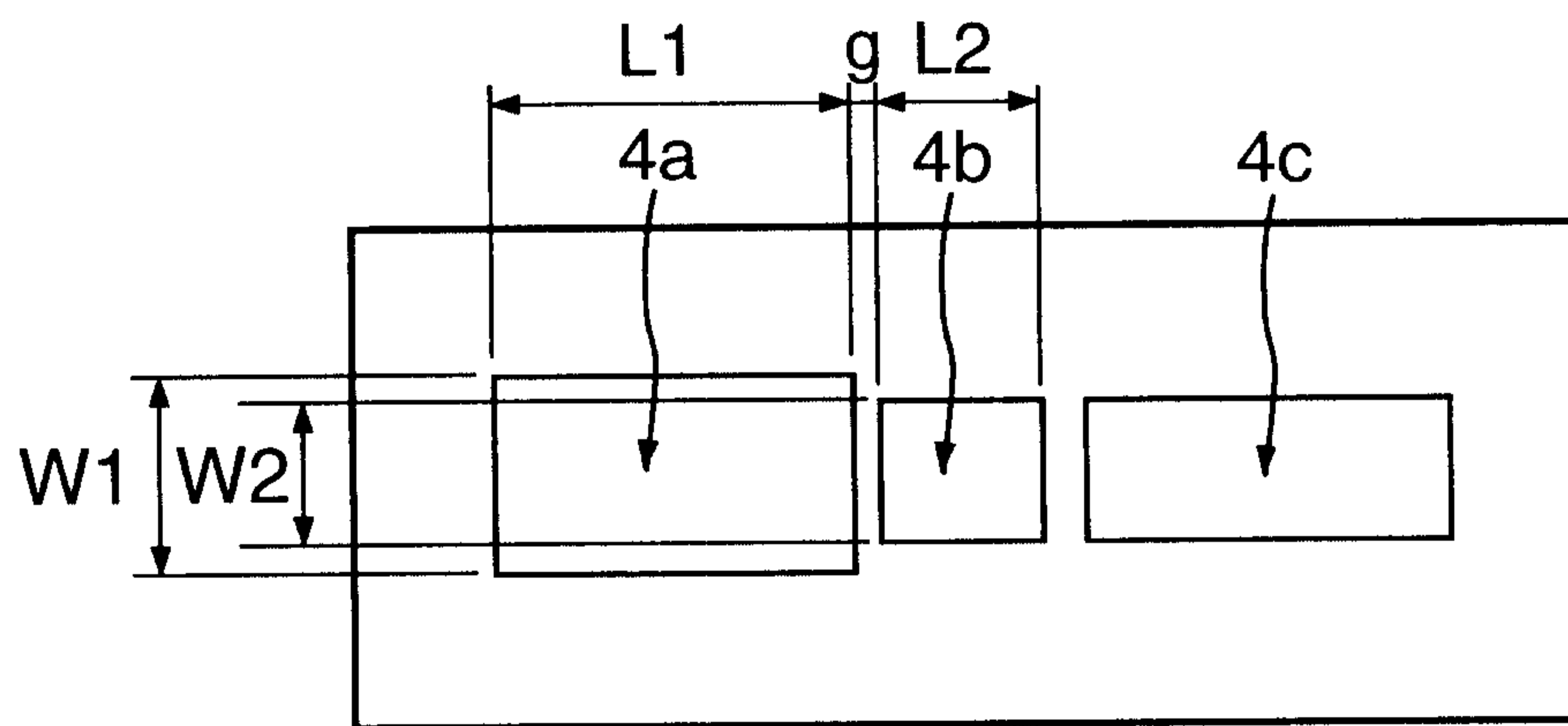

FIG. 9C

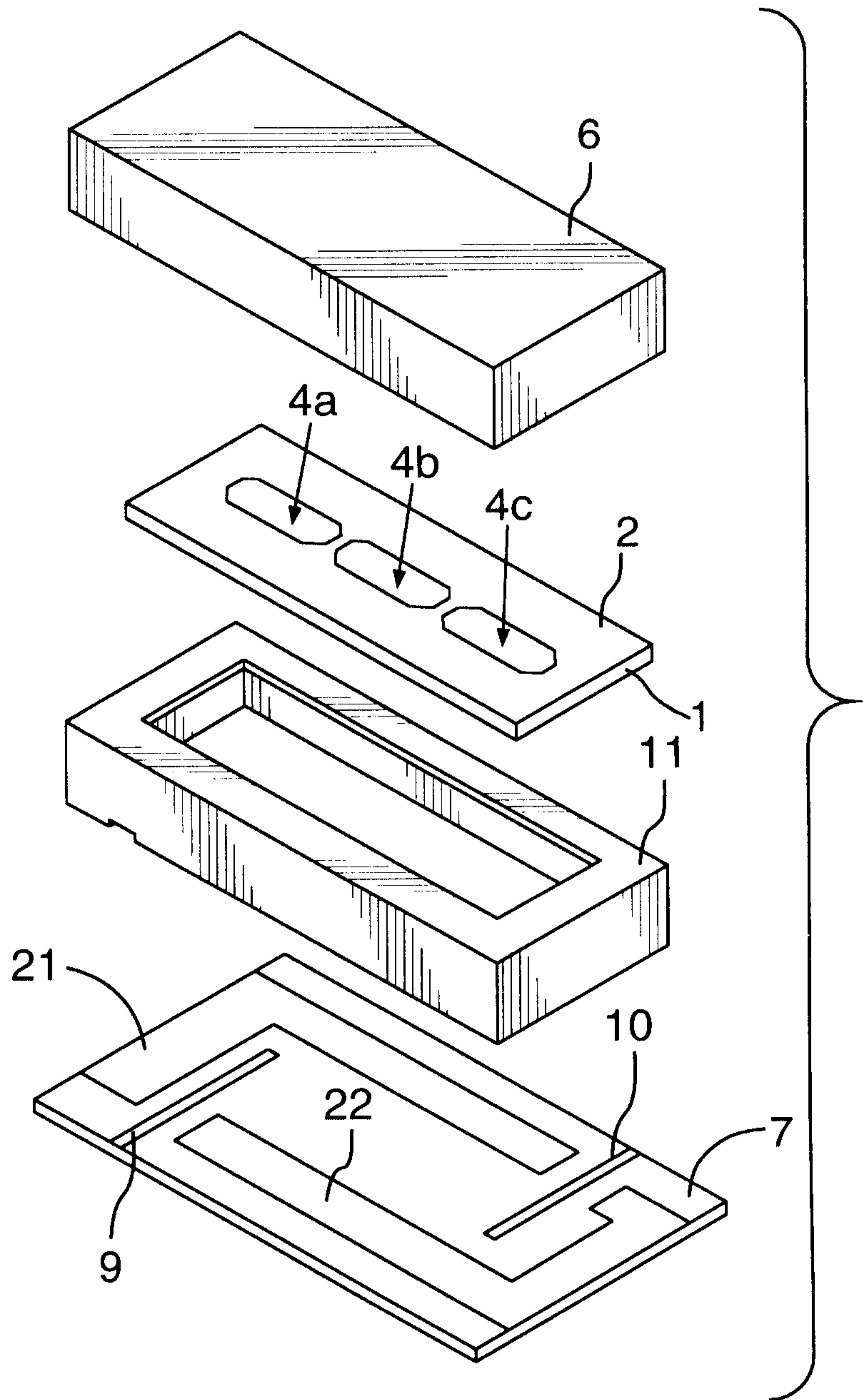

FIG. 10A

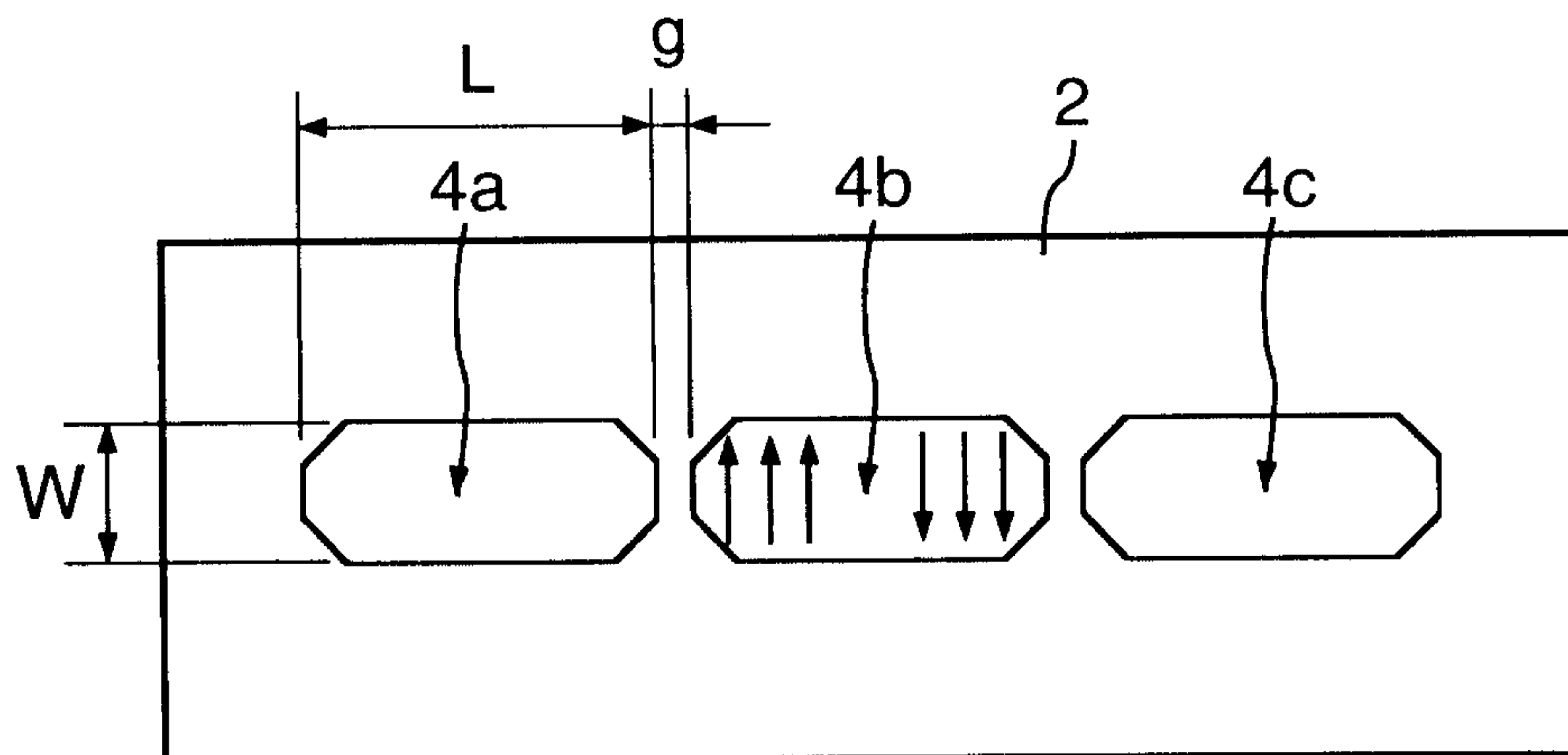

FIG. 10B

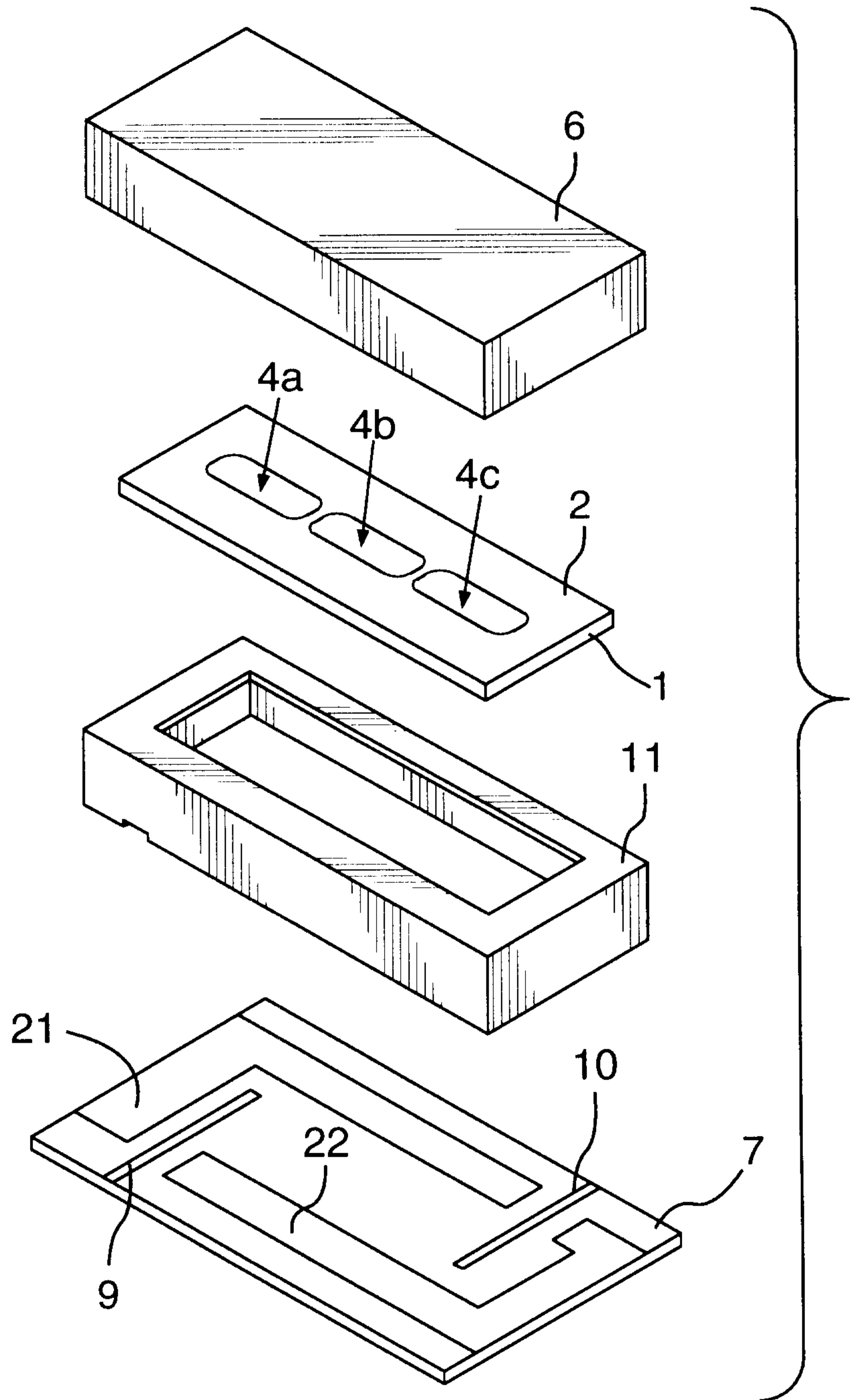
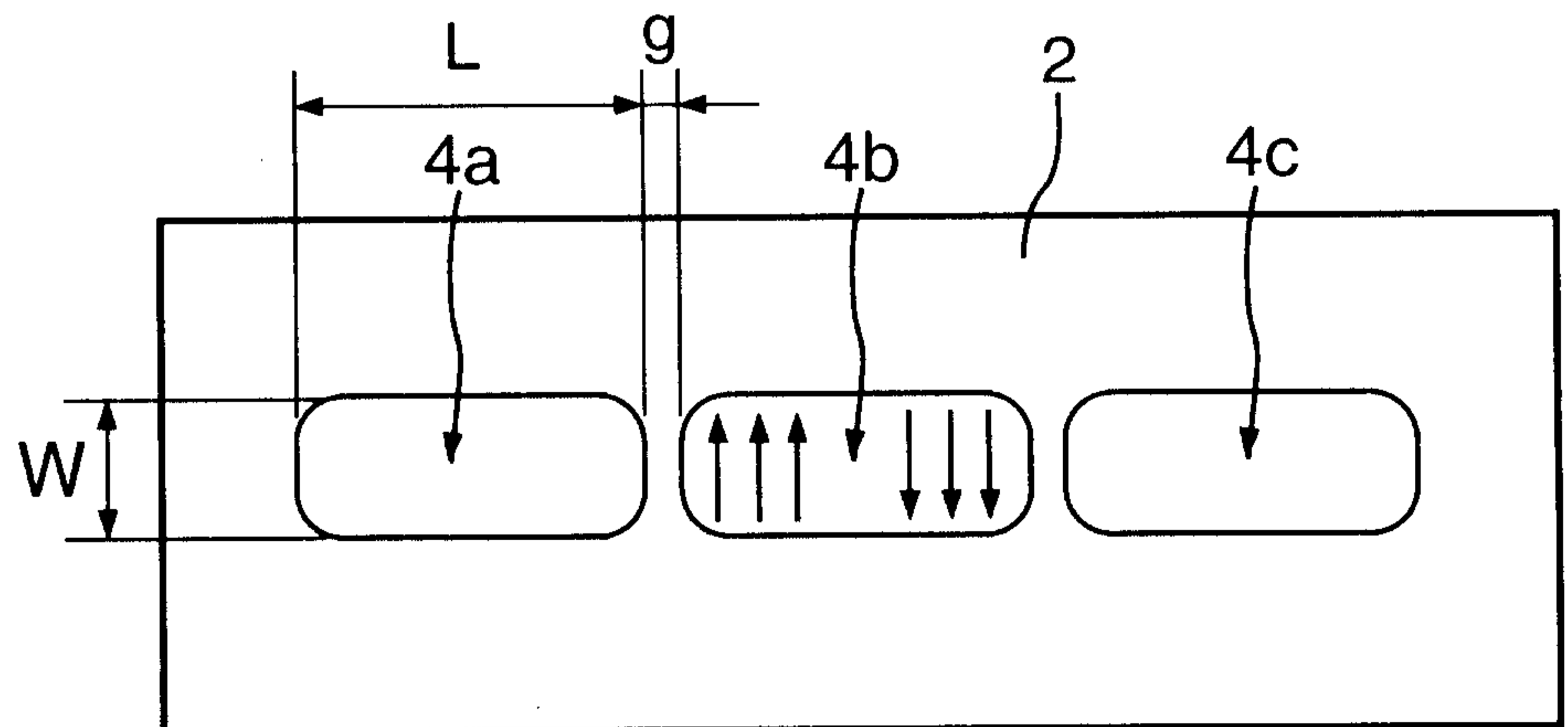

FIG.11A

FIG.11B



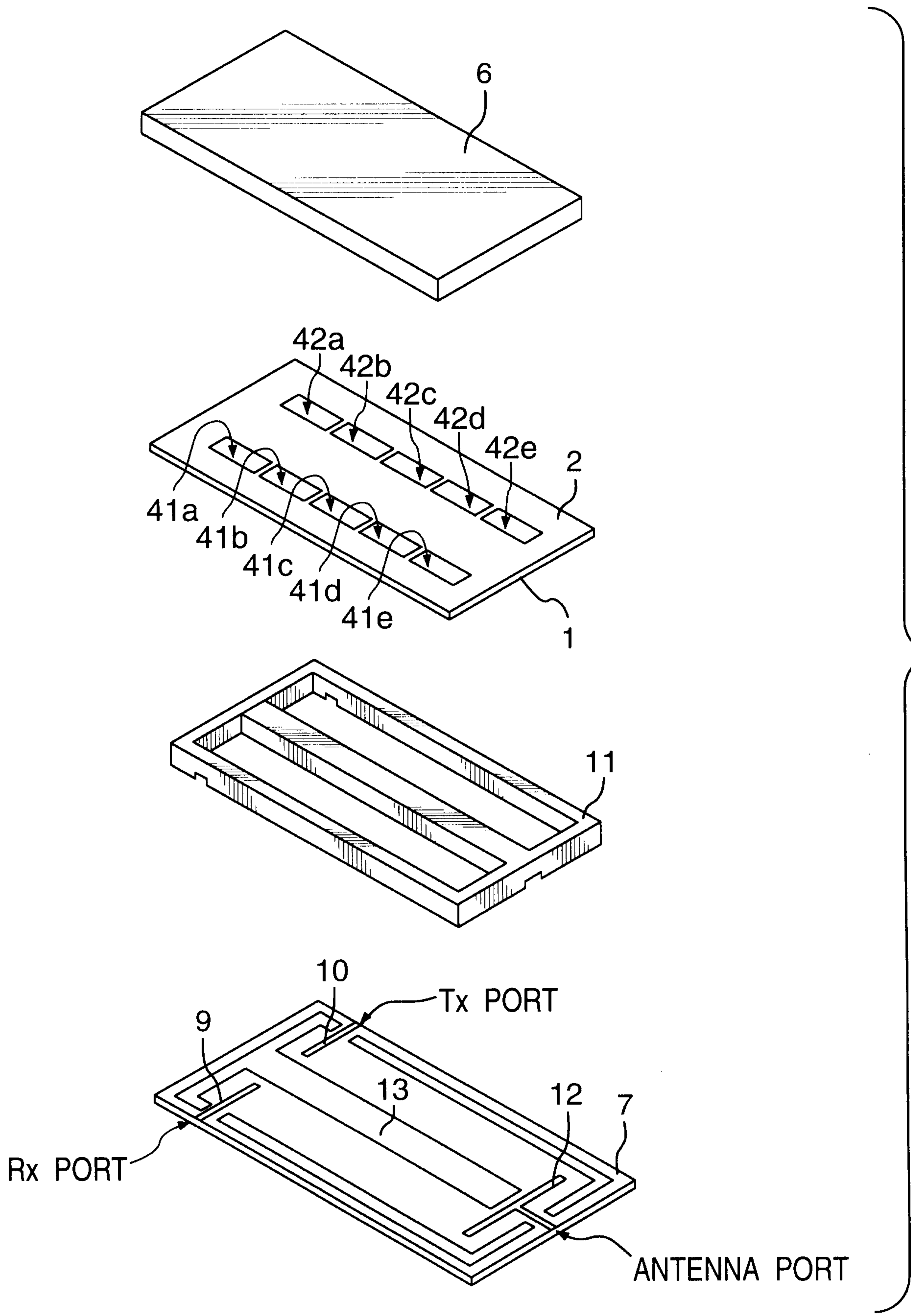

FIG.12

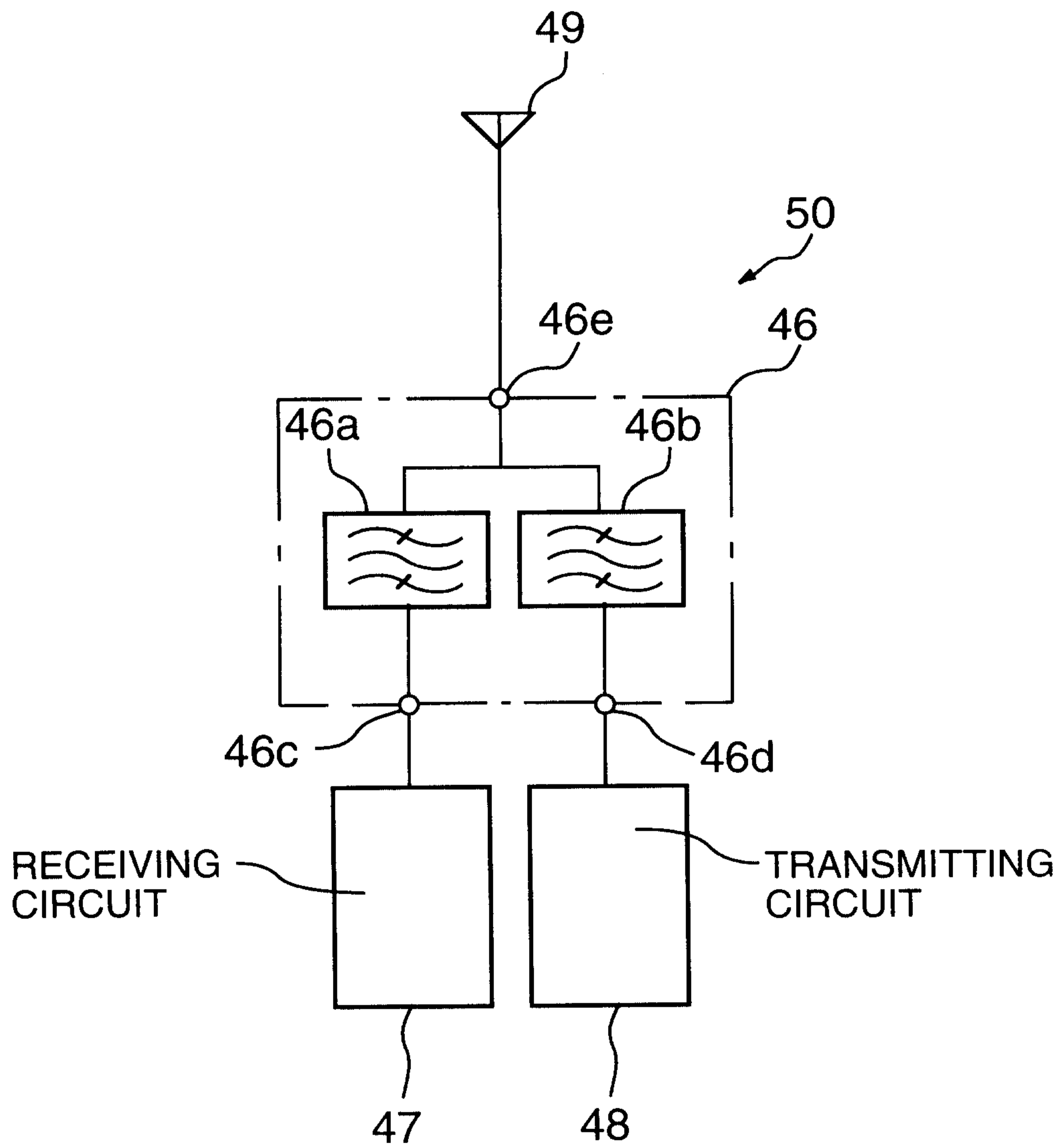

FIG.13

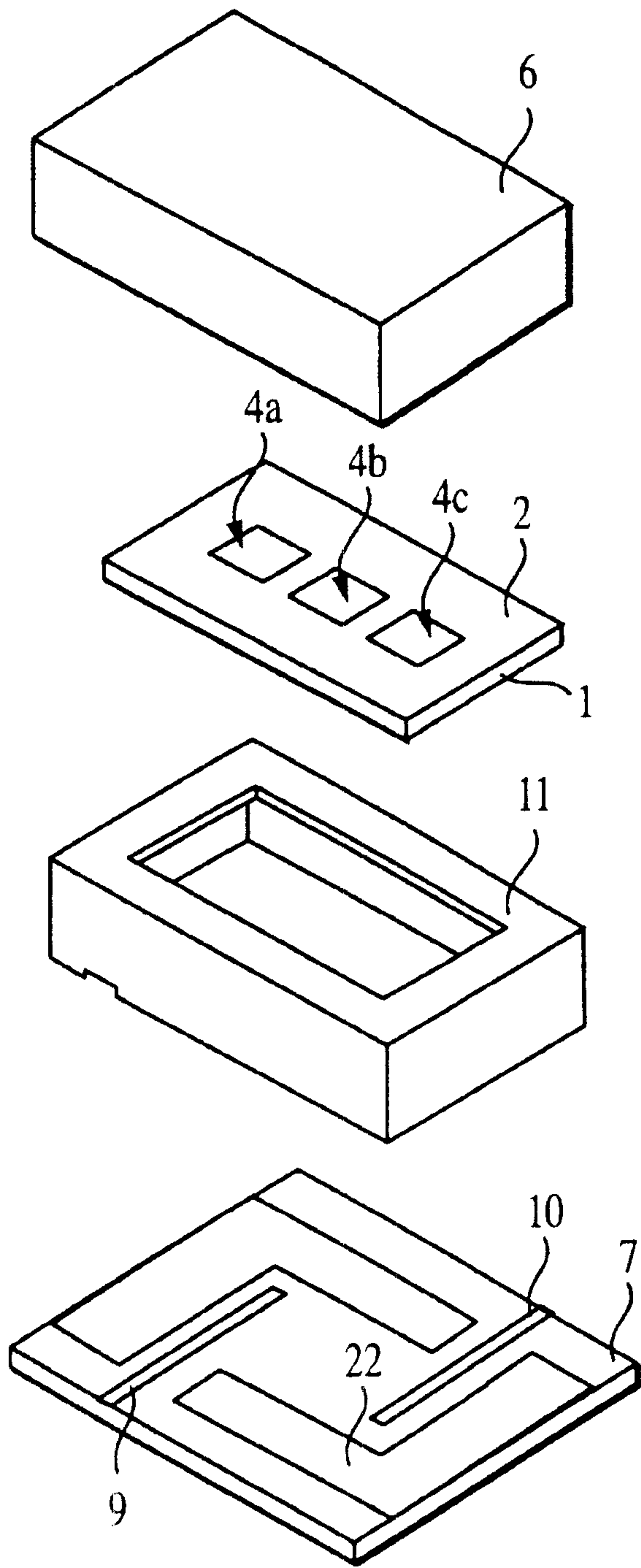

FIG. 14
PRIOR ART

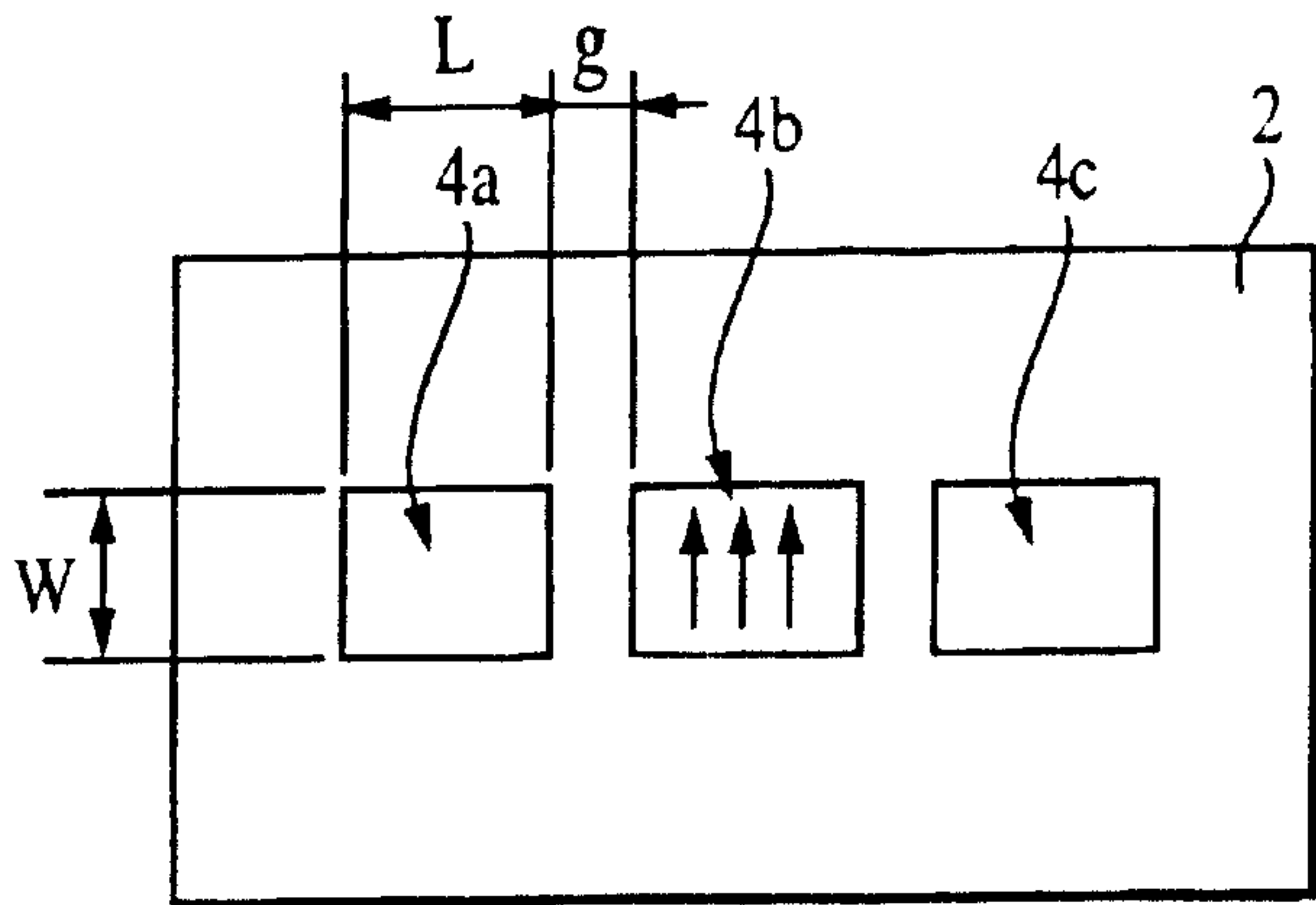

FIG. 15A
PRIOR ART

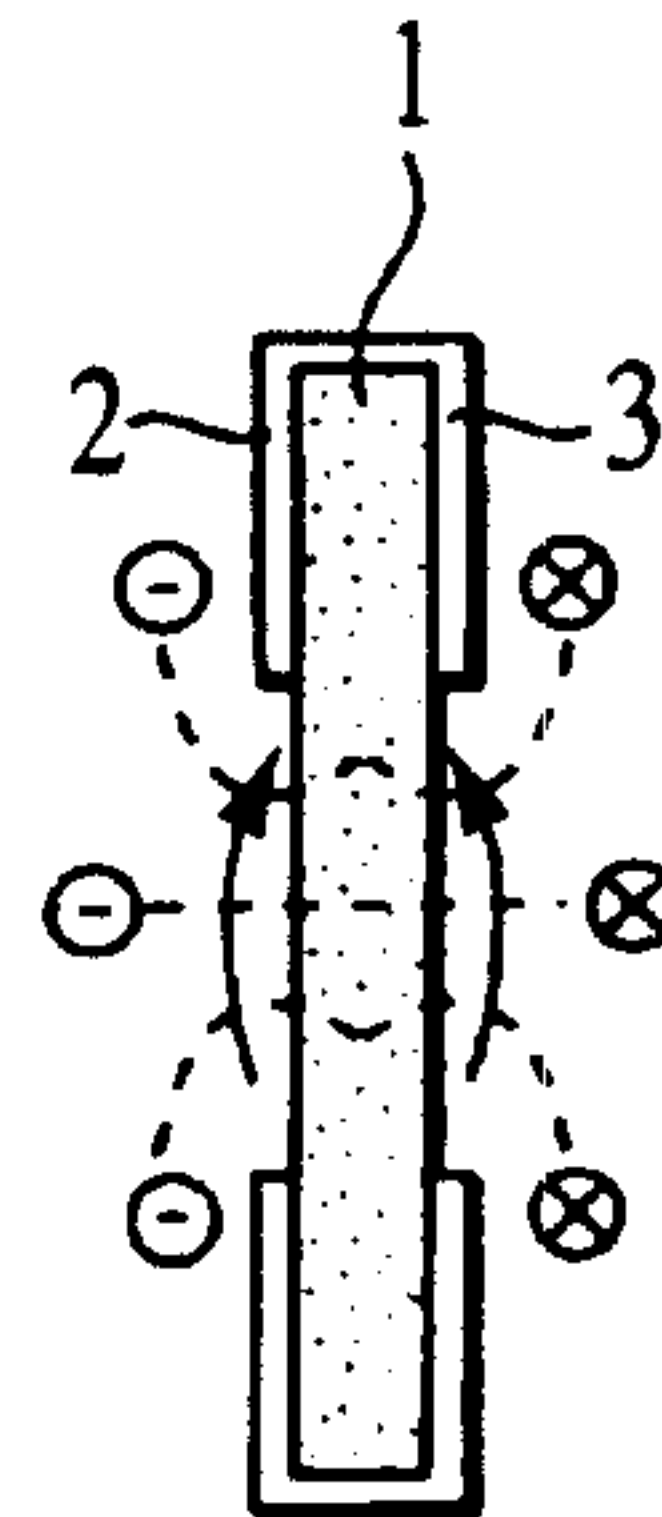

FIG. 15C
PRIOR ART

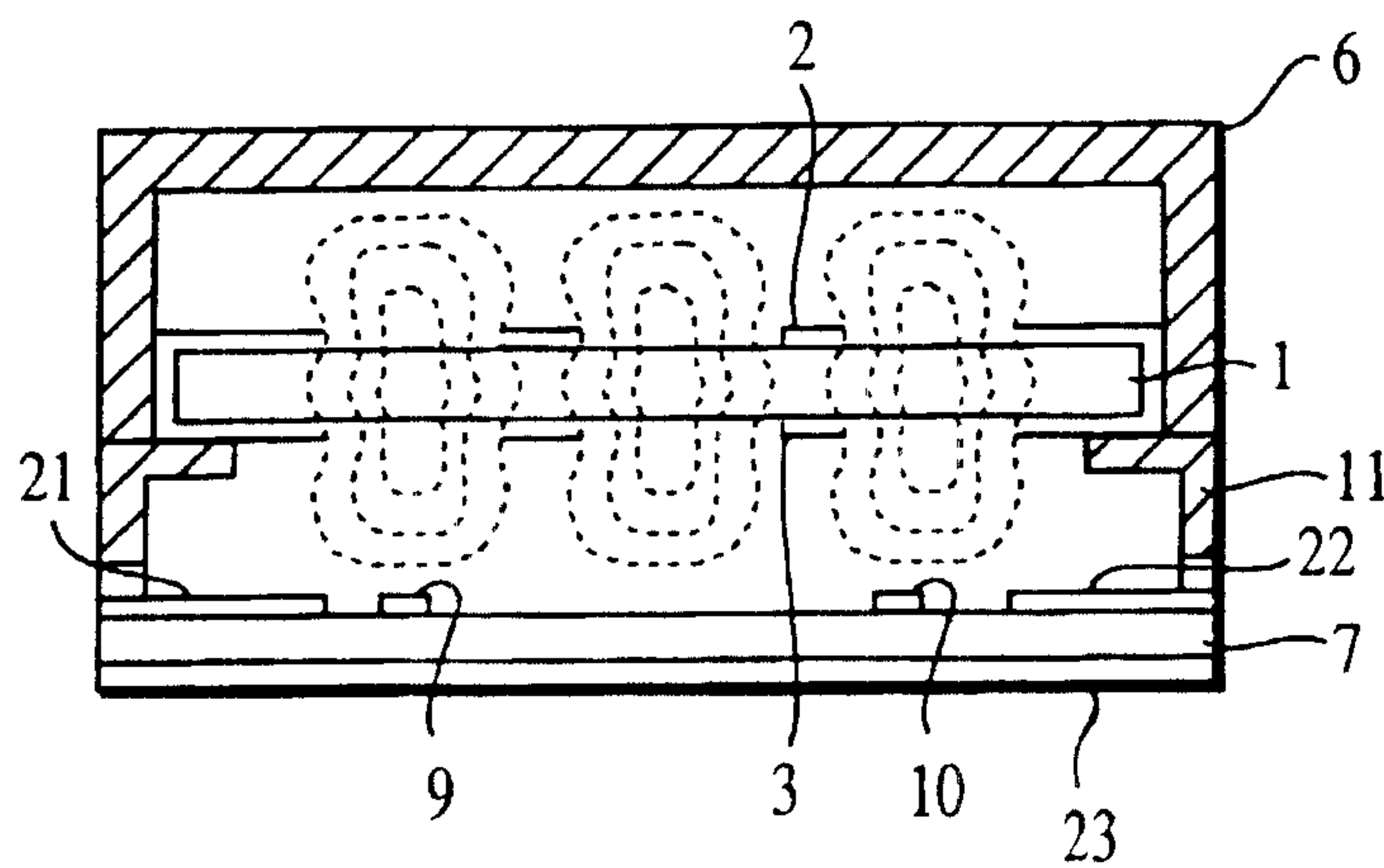

FIG. 15B
PRIOR ART

