

T. WIGLEY.  
Carriage Lantern.

No. 133,735.

Patented Dec. 10, 1872.

Fig. 1

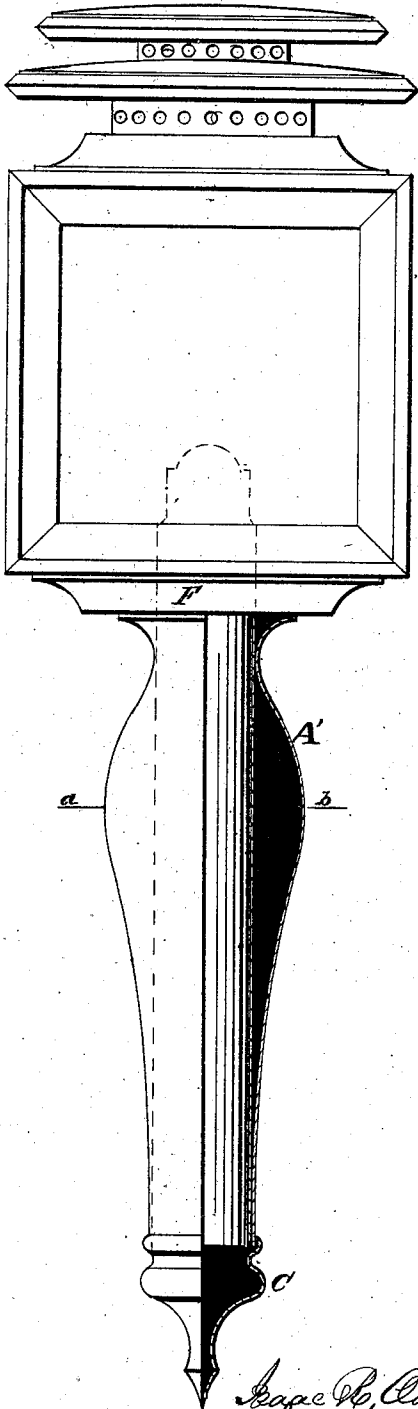

WITNESSES. *George H. Clark*,  
*Isaac Tomison*

Fig. 2

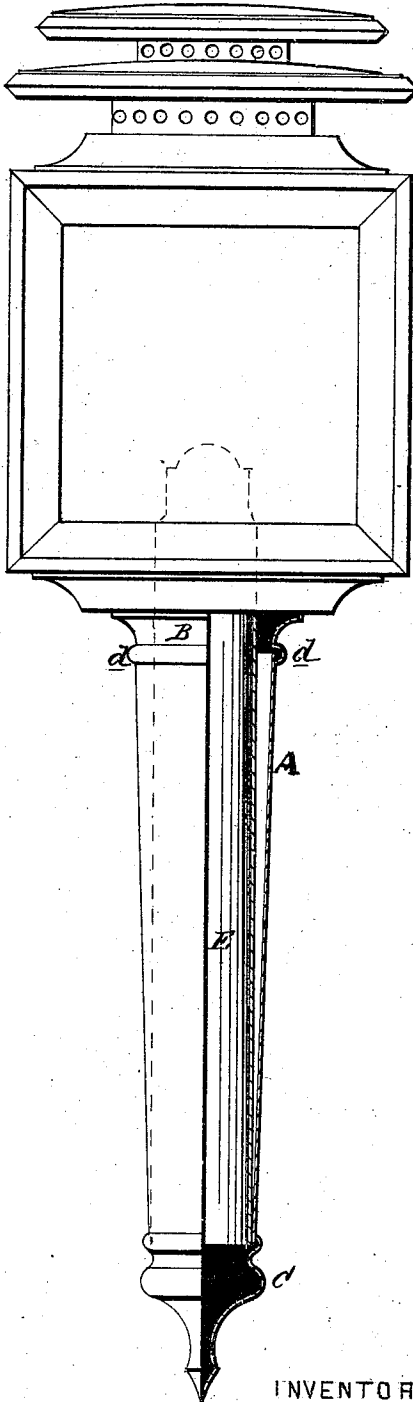

INVENTOR.  
*Thomas Wigley*

# UNITED STATES PATENT OFFICE.

THOMAS WIGLEY, OF BRIDGEPORT, CONNECTICUT.

## IMPROVEMENT IN CARRIAGE-LANTERNS.

Specification forming part of Letters Patent No. 133,735, dated December 10, 1872.

*To all whom it may concern:*

Be it known that I, THOMAS WIGLEY, of Bridgeport, in the county of Fairfield and State of Connecticut, have invented a certain Improvement in Vehicle-Lamps, of which the following is a specification:

My invention relates to the construction of that portion of vehicle-lamps commonly known to the trade as the stem, or tail-and-stem, or tail-collar; and consists in spinning these parts from one piece of metal, the object of which is to dispense with the soldered joint at the junction of the collar and stem, as now employed in the manufacture of the present style of vehicle-lamp. This joint is liable to work loose, owing to the constant shaking or jarring of the vehicle, and the stem to become not only loose and mar the finish of the lamp, but to frequently become detached and lost in the street when the vehicle is in motion; whereas in my invention this is obviated in making the collar and stem of one continuous piece; at the same time a better finish is obtained.

Figure 1 is a side elevation of my improvement in vehicle-lamps with a portion of the stem or tail shown in a longitudinal section. Fig. 2 is a side elevation of the present style of vehicle-lamp with a portion of the stem and stem-collar shown in a longitudinal section.

A, Fig. 2, represents the present style of stem or tail, which is joined at *d d*, by means of solder, to the stem or tail-collar B. The sides of the said stem are made straight and taper toward the lower end or tip C, with the

inside stem or socket E secured in the center of it. The stem in this case is formed on a tapering mandrel, and is then attached to the collar, which has been previously spun upon the lathe. The stem or tail A', Fig. 1, of my invention is spun on a lathe with a sectional chuck from one piece of metal, and is soldered directly to the lower panel F of the body of the lamp without the interposition of the collar, as in the present style. In order to give greater beauty of finish to the stem the sides of it are swelled out on the line *a b*, and are gradually contracted toward the end or tip C, and above the line *a b* they are curved gracefully inward until the upper end is reached, where they spread outward to form a broad base for the panel F to rest on.

In making the sides of the stem in the form above described, or in any form where a portion of it is to be swelled out or increased in area, a sectional chuck is to be used on the lathe, arranged so as to be taken apart and passed through the opening in the upper part of the stem.

What I claim as my invention is—

The stem A', spun in the form as shown from one piece of metal, and attached directly to the lower panel F of the lamp, substantially in the manner and for the purpose herein shown and described.

THOMAS WIGLEY.

Witnesses:

ISAAC R. OAKFORD,  
ISAAC TOWNSEND.