

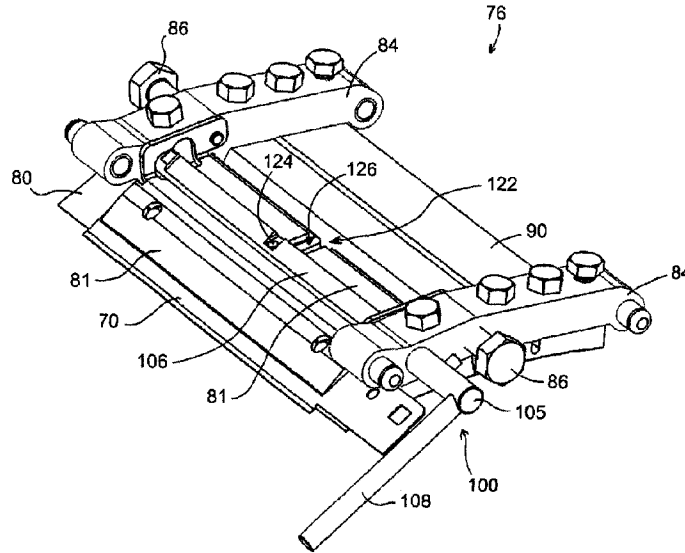

(86) Date de dépôt PCT/PCT Filing Date: 2018/05/11  
 (87) Date publication PCT/PCT Publication Date: 2018/11/22  
 (45) Date de délivrance/Issue Date: 2022/01/18  
 (85) Entrée phase nationale/National Entry: 2019/11/13  
 (86) N° demande PCT/PCT Application No.: US 2018/032365  
 (87) N° publication PCT/PCT Publication No.: 2018/213130  
 (30) Priorité/Priority: 2017/05/16 (US62/506,667)

(51) Cl.Int./Int.Cl. *B26D 1/36* (2006.01),  
*B26D 1/00* (2006.01), *B26D 3/28* (2006.01),  
*B26D 7/26* (2006.01)  
 (72) Inventeurs/Inventors:  
 GREGG, DUSTIN JOSEPH, US;  
 JACKO, MICHAEL SCOT, US  
 (73) Propriétaire/Owner:  
 URSCHEL LABORATORIES, INC., US  
 (74) Agent: CRAIG WILSON AND COMPANY

(54) Titre : UNITES MODULAIRES, ENSEMBLES DE SERRAGE, ET MACHINES A TRANCHER EQUIPEES DE CEUX-  
 CI  
 (54) Title: MODULAR UNITS, CLAMPING ASSEMBLIES, AND SLICING MACHINES EQUIPPED THEREWITH



(57) **Abrégé/Abstract:**

Modular units with clamping assemblies for securing knives to slicing machines, and a slicing machine having a cutting head equipped with one or more modular units mounted thereto for securing knives to the cutting head. Such a clamping assembly includes a knife holder, a knife supported by the knife holder, a clamp overlying the knife holder so that the knife is between the knife holder and the clamp, and a cam rod that secures the clamp to the knife holder and clamps the knife therebetween. The cam rod has oppositely-disposed ends rotatably coupled with the mounting blocks and a camming portion between the oppositely-disposed ends and arranged for contacting the clamp. The clamping assembly further includes complementary features for inhibiting deflection of the camming portion away from the knife holder when the cam rod is in a clamping position.

## (12) INTERNATIONAL APPLICATION PUBLISHED UNDER THE PATENT COOPERATION TREATY (PCT)

(19) World Intellectual Property  
Organization  
International Bureau



(10) International Publication Number  
**WO 2018/213130 A1**

(43) International Publication Date  
22 November 2018 (22.11.2018)

## (51) International Patent Classification:

*B26D 1/36* (2006.01)      *B26D 1/00* (2006.01)  
*B26D 7/26* (2006.01)      *B26D 3/28* (2006.01)

## (21) International Application Number:

PCT/US2018/032365

## (22) International Filing Date:

11 May 2018 (11.05.2018)

## (25) Filing Language:

English

## (26) Publication Language:

English

## (30) Priority Data:

62/506,667      16 May 2017 (16.05.2017)      US

(71) Applicant: **URSCHEL LABORATORIES, INC.**  
[US/US]; 1200 Cutting Edge Dr., Chesterton, Indiana 46304  
(US).

(72) Inventors: **GEREG, Dustin Joseph**; 1643 Southview Dr.,  
Lowell, Indiana 46356 (US). **JACKO, Michael Scot**; 877  
North 400 East, Valparaiso, Indiana 46383 (US).

(74) Agent: **HARTMAN, Domenica N.S.** et al.; HARTMAN  
GLOBAL IP LAW, 2621 Chicago St., Suite A, Valparaiso,  
Indiana 46383 (US).

(81) Designated States (*unless otherwise indicated, for every  
kind of national protection available*): AE, AG, AL, AM,  
AO, AT, AU, AZ, BA, BB, BG, BH, BN, BR, BW, BY, BZ,  
CA, CH, CL, CN, CO, CR, CU, CZ, DE, DJ, DK, DM, DO,  
DZ, EC, EE, EG, ES, FI, GB, GD, GE, GH, GM, GT, HN,  
HR, HU, ID, IL, IN, IR, IS, JO, JP, KE, KG, KH, KN, KP,  
KR, KW, KZ, LA, LC, LK, LR, LS, LU, LY, MA, MD, ME,  
MG, MK, MN, MW, MX, MY, MZ, NA, NG, NI, NO, NZ,  
OM, PA, PE, PG, PH, PL, PT, QA, RO, RS, RU, RW, SA,  
SC, SD, SE, SG, SK, SL, SM, ST, SV, SY, TH, TJ, TM, TN,  
TR, TT, TZ, UA, UG, US, UZ, VC, VN, ZA, ZM, ZW.

(54) Title: MODULAR UNITS, CLAMPING ASSEMBLIES, AND SLICING MACHINES EQUIPPED THEREWITH

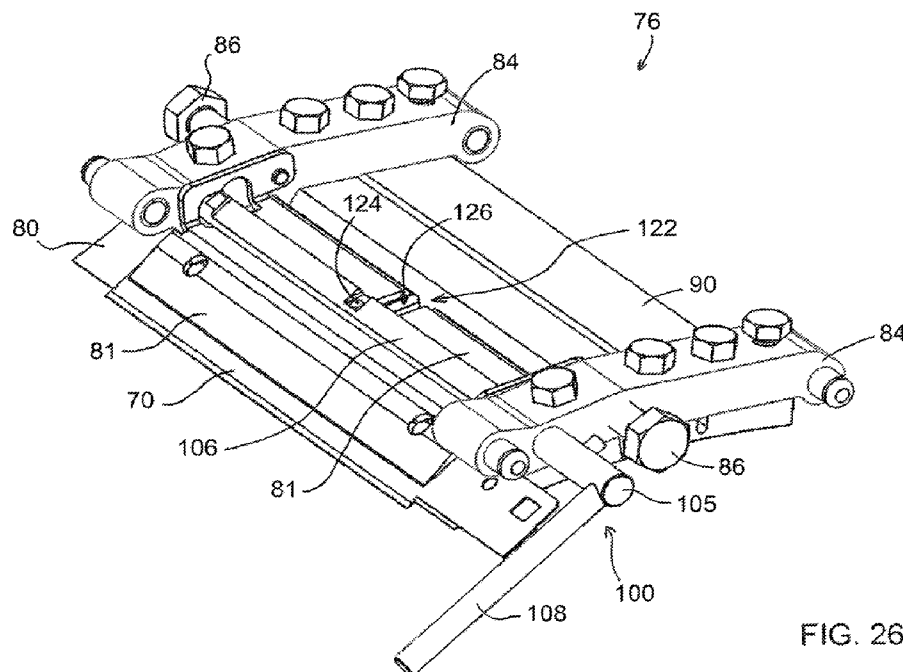

FIG. 26

(57) Abstract: Modular units with clamping assemblies for securing knives to slicing machines, and a slicing machine having a cutting head equipped with one or more modular units mounted thereto for securing knives to the cutting head. Such a clamping assembly includes a knife holder, a knife supported by the knife holder, a clamp overlying the knife holder so that the knife is between the knife holder and the clamp, and a cam rod that secures the clamp to the knife holder and clamps the knife therebetween. The cam rod has oppositely-disposed ends rotatably coupled with the mounting blocks and a camming portion between the oppositely-disposed ends and arranged for contacting the clamp. The clamping assembly further includes complementary features for inhibiting deflection of the camming portion away from the knife holder when the cam rod is in a clamping position.

[Continued on next page]

**WO 2018/213130 A1** 

**(84) Designated States** (*unless otherwise indicated, for every kind of regional protection available*): ARIPO (BW, GH, GM, KE, LR, LS, MW, MZ, NA, RW, SD, SL, ST, SZ, TZ, UG, ZM, ZW), Eurasian (AM, AZ, BY, KG, KZ, RU, TJ, TM), European (AL, AT, BE, BG, CH, CY, CZ, DE, DK, EE, ES, FI, FR, GB, GR, HR, HU, IE, IS, IT, LT, LU, LV, MC, MK, MT, NL, NO, PL, PT, RO, RS, SE, SI, SK, SM, TR), OAPI (BF, BJ, CF, CG, CI, CM, GA, GN, GQ, GW, KM, ML, MR, NE, SN, TD, TG).

**Published:**

— *with international search report (Art. 21(3))*

MODULAR UNITS, CLAMPING ASSEMBLIES,  
AND SLICING MACHINES EQUIPPED THEREWITH

CROSS REFERENCE TO RELATED APPLICATIONS

**[0001]** This application claims the benefit of U.S. Provisional Application No. 62/506,667, filed May 16, 2017.

BACKGROUND OF THE INVENTION

**[0002]** The present invention generally relates to machines for cutting products, including but not limited to slicing food products. The invention particularly relates to modular units with clamping assemblies for securing knives to slicing machines, and to slicing machines equipped therewith.

**[0003]** Various types of equipment are known for slicing, shredding and granulating food products, as nonlimiting examples, vegetables, fruits, dairy products, and meat products. Widely used machines for this purpose are commercially available from Urschel Laboratories, Inc., and include machines under the names Model CC® and Model CCL. The Model CC and CCL machines are centrifugal-type slicers capable of slicing a wide variety of products at high production capacities. The Model CC® line of machines is particularly adapted to produce uniform slices, strip cuts, shreds and granulations, and the Model CCL line is particularly adapted to produce slices or chips of a waffle or lattice type. Certain configurations and aspects of Model CC® machines are represented in U.S. Patent Nos. 3,139,128, 3,139,129, 5,694,824 and 6,968,765. Certain configurations and aspects of Model CCL machines are represented in U.S. Patent Nos. 3,139,127 and 3,139,130.

**[0004]** FIG. 1 schematically depicts a machine 10 representative of a Model CC® machine. The machine 10 includes a generally annular-shaped cutting head 12 equipped with cutting knives (not shown) mounted at its inner circumference. An impeller 14 is coaxially mounted within the cutting head 12 and has an axis 17 of rotation that coincides with an axis of the cutting head 12. The impeller 14 is rotationally driven about its axis 17 through a shaft that is enclosed within a housing 18 and coupled to a gear box 16. The cutting head 12 is mounted on a support ring 15 above the gear box 16 and remains stationary as the impeller 14 rotates. Products are delivered to the cutting head 12 and impeller 14 through a feed hopper 11 located above the impeller 14. In operation, as the hopper 11 delivers products to the impeller 14, centrifugal forces cause the products to move outward into engagement with the knives of the cutting head 12. The impeller 14 comprises generally radially-oriented paddles 13, each having a face that engages and directs the products radially outward toward and against the knives of the cutting head 12 as the impeller 14 rotates. Other aspects pertaining to the construction and operation of Model CC® machines, including improved embodiments thereof, can be appreciated from U.S. Patent Nos. 3,139,128, 3,139,129, 5,694,824, 6,968,765, 7,658,133, 8,161,856, 9,193,086, 9,469,041, and 9,517,572 and U.S. Patent Application Publication Nos. 2016/0158953 and 2016/0361831.

**[0005]** FIG. 2 is an isolated view of the cutting head 12 of FIG. 1, and FIG. 3 is a fragmentary bottom view of the cutting head 12. The cutting head 12 is generally annular-shaped with cutting knives 20 mounted on its perimeter. Each knife 20 projects radially inward in a direction generally opposite the direction of rotation of the impeller 14, and defines a cutting edge at its radially innermost extremity. The cutting head 12 shown in FIG. 2 further comprises a lower support ring 22, an upper support ring 24, and circumferentially-spaced support segments, referred to herein

as shoes 26. The knives 20 of the cutting head 12 are individually secured with clamping assemblies 28 to the shoes 26. Each clamping assembly 28 includes a knife holder 28A mounted with fasteners 29 to the radially inward-facing side of a shoe 26, and a clamp 28B mounted on the radially outward-facing side of a shoe 26 to secure a knife 20 to the knife holder 28A. The shoes 26 are represented as secured with fasteners 30 to the support rings 22 and 24. The shoes 26 are equipped with coaxial pivot pins (not shown) that engage holes in the support rings 22 and 24. By pivoting on its pins, the orientation of a shoe 26 can be adjusted to alter the radial location of the cutting edge of its knife 20 with respect to the axis of the cutting head 12, thereby controlling the thickness of the sliced food product. As an example, adjustment can be achieved with an adjusting screw and/or pin 32 located circumferentially behind the pivot pins. FIG. 2 further shows optional gate insert strips 34 mounted with fasteners 35 to each shoe 26, which the food product crosses prior to encountering the knife 20 mounted to the succeeding shoe 26.

**[0006]** FIGS. 2 and 3 show the knives 20 and clamps 28B secured to their respective knife holders 28A with fasteners 36. Alignment of the knife 20 and clamp 28B of each assembly 28 is achieved with pins 38 that protrude from the support surface of the knife holder 26B. As better understood through the detail view of FIG. 4, the opposing surfaces of the knife holder 28A and clamp 28B result in the clamp 28B applying a force to the knife 20 adjacent its cutting edge. FIG. 5 shows an isolated exploded view of a shoe 26 and clamping assembly 28 of the cutting head 12 of FIGS. 2 and 3.

**[0007]** FIGS. 6 and 7 depict a quick-clamping assembly 40 that can be used in lieu of the fasteners 36 shown in FIGS. 2 and 3. The clamping assembly 40 comprises a knife holder 40A and clamp 40B, the latter of which may be similar if not identical to the clamp 28B of FIGS. 2 and 3. The knife holder 40A includes an insert 42 that supports the knife 20 near its cutting edge and serves to protect the

edge of the knife holder 40A from stones or other debris that are often accompany food products that undergo slicing. The knife holder 40A and clamp 40B are loosely assembled together with a fastener 44 that is installed in the knife holder 40A, passes through the clamp 40B, and is threaded into a clamping bar 46. An eccentric clamping rod 48 is disposed within a recess 50 formed in a surface of the knife holder 40A, and has a flat 52 defined on its otherwise cylindrical peripheral surface. The clamping rod 48 is situated between and contacts the knife holder 40A and a proximal end of the clamp 40B opposite the knife 20. The rod 48 can be rotated between clamping and release positions, which serve to secure and release, respectively, the knife 20. The clamping position is depicted in FIG. 6 and results from the proximal end of the clamp 40B being engaged by the cylindrical surface of the rod 48, which forces the proximal end outward away from the knife holder 40A and, with the clamping bar 46 serving as a fulcrum, forces the oppositely-disposed end of the clamp 40B into engagement with the knife 20. The force applied to the clamp 40B by the rod 48 can be released by rotating the rod 48 so that its flat 52 faces the proximal end of the clamp 40B.

**[0008]** While the Model CC® has performed extremely well for its intended purpose, further improvements are continuously desired and sought for slicing machines of the type represented by the Model CC®.

#### BRIEF DESCRIPTION OF THE INVENTION

**[0009]** The present invention provides modular units with clamping assemblies for securing knives to slicing machines, and a slicing machine having a cutting head equipped with one or more modular units mounted thereto for securing knives to the cutting head.

**[0010]** According to one aspect of the invention, a modular unit is provided that

comprises mounting blocks that are spaced apart in an axial direction, and a clamping assembly assembled with the mounting blocks so as to be between the mounting blocks. According to a preferred aspect of the invention, the clamping assembly includes a knife holder, a knife supported by the knife holder, a clamp overlying the knife holder so that the knife is between the knife holder and the clamp, and a cam rod that secures the clamp to the knife holder and clamps the knife therebetween. The cam rod has oppositely-disposed ends rotatably coupled with the mounting blocks and a camming portion between the oppositely-disposed ends and arranged for contacting the clamp. The cam rod is rotatable to have a clamping position and a release position, the camming portion applies a force that clamps the clamp against the knife holder when the cam rod is in the clamping position, and the camming portion releases the force against the clamp when the cam rod is in the release position. The clamping assembly further includes means for inhibiting deflection of the camming portion away from the knife holder when the cam rod is in the clamping position.

**[0011]** According to another preferred aspect of the invention, a slicing machine is provided that includes a cutting head to which a modular unit of the type described above can be mounted. The cutting head of such a machine may optionally comprise a first stop that prevents rotation of the cam rod beyond the clamping position and a second stop that prevents rotation of the cam rod beyond the release position.

**[0012]** Other aspects of the invention include methods by which a slicing machine of the type described above can be modified.

**[0013]** Technical aspects of modular units described above preferably include the ability to minimize the extent to which the camming portion of the cam rod can deflect when engaged with and applying a clamping force to the clamp, and the

ability to promote a more uniform clamping force applied by the clamp along the length of the knife.

**[0014]** Other aspects and advantages of this invention will be better appreciated from the following detailed description.

#### BRIEF DESCRIPTION OF THE DRAWINGS

**[0015]** FIG. 1 schematically represents a side view in partial cross-section of a slicing machine known in the art.

**[0016]** FIG. 2 is a perspective view representing a cutting head of a type suitable for use with the slicing machine of FIG. 1.

**[0017]** FIG. 3 is a bottom view showing a fragment of the cutting head of FIG. 2, and FIG. 4 is a detailed view of a portion of a clamping assembly of the cutting head.

**[0018]** FIG. 5 is an isolated exploded view of a shoe and a clamping assembly of the cutting head of FIGS. 2 and 3.

**[0019]** FIGS. 6 and 7 are side and cross-sectional views, respectively, of an alternative clamping assembly capable of use with the cutting head of FIG. 2.

**[0020]** FIG. 8 is a perspective view representing a cutting head in accordance with a nonlimiting embodiment of the invention and configured for use with the slicing machine of FIG. 1.

**[0021]** FIG. 9 is a perspective view of an individual modular unit assembled to support rings of the cutting head of FIG. 8.

**[0022]** FIG. 10 contains isolated perspective and exploded views of the modular unit of FIG. 9.

**[0023]** FIG. 11 is a cross-sectional view of a modular unit of the type represented in FIGS. 8 through 10.

**[0024]** FIG. 12 is a cross-sectional view of the modular unit of FIG. 11 showing the unit in a closed position by which a flat knife is secured to the unit, and FIG. 13 is an end view of a portion of a cutting head representing the position of a lever relative to a support ring to which the modular unit of FIG. 12 is mounted.

**[0025]** FIG. 14 is a cross-sectional view of the modular unit of FIGS. 11 and 12 showing the unit in an open position by which the flat knife is released from the unit, and FIG. 15 is an end view of a portion of a cutting head representing the position of the lever relative to the support ring.

**[0026]** FIG. 16 is a perspective view of a shaped knife.

**[0027]** FIG. 17 is a cross-sectional view of the modular unit of FIGS. 11, 12 and 14 showing the unit in an open position by which a shaped knife is released from the unit, and FIG. 18 is an end view of a portion of a cutting head representing the position of the lever relative to a support ring modified for use with the shaped knife of FIG. 16.

**[0028]** FIG. 19 is a perspective view corresponding to the portion of the cutting

head of FIGS. 14 and 15 and showing stops for the lever that operates the modular unit in combination with the flat knife as depicted in FIGS. 12 through 15.

**[0029]** FIG. 20 is a perspective view corresponding to the portion of the cutting head of FIGS. 17 and 18 and showing stops for the lever that operates the modular unit in combination with the shaped knife as depicted in FIGS. 17 and 18.

**[0030]** FIGS. 21, 22 and 23 are perspective views evidencing the modularity of the modular unit of FIGS. 8 through 20.

**[0031]** FIGS. 24 and 25 are end views of cutting heads showing the modular unit of FIGS. 8 through 23 installed on support rings of different size (diameters).

**[0032]** FIGS. 26 through 33 contain various views representing a modular unit comprising a locking feature in accordance with another nonlimiting embodiment of the invention.

#### DETAILED DESCRIPTION OF THE INVENTION

**[0033]** FIG. 8 represents a cutting head 62 that is capable of use with a variety of cutting machines, including the slicing machine 10 depicted in FIG. 1, and in some instances may be a modification or retrofit for such a machine. FIGS. 9 through 33 contain various views of nonlimiting embodiments that utilize one or more modular units 76 to secure knives 70 to the cutting head 62. The cutting head 62 will be described hereinafter in reference to the slicing machine 10 of FIG. 1 equipped with an impeller 14 as described in reference to FIG. 1, and as such the following discussion will focus primarily on certain aspects of the invention, whereas other aspects not discussed in any detail may be, in terms of structure, function,

materials, etc., essentially as was described in reference to FIGS. 1 through 7. However, it will be appreciated that the teachings of the invention are more generally applicable to other types of cutting machines.

**[0034]** To facilitate the description provided below of the embodiments represented in the drawings, relative terms, including but not limited to, “vertical,” “horizontal,” “lateral,” “front,” “rear,” “side,” “forward,” “rearward,” “upper,” “lower,” “above,” “below,” “right,” “left,” etc., may be used in reference to the orientation of the cutting head 62 as it would be mounted in the machine 10 of FIG. 1. On the basis of a coaxial arrangement of the cutting head 62 and the impeller 14 of the machine 10, relative terms including but not limited to “axial,” “circumferential,” “radial,” etc., and related forms thereof may also be used below to describe the nonlimiting embodiments represented in the drawings. All such relative terms are intended to indicate the construction and relative orientations of components and features of the cutting head 62, and therefore are relative terms that are useful to describe the illustrated embodiments but should not be otherwise interpreted as limiting the scope of the invention.

**[0035]** In the isolated view of FIG. 8, the cutting head 62 can be seen to be generally annular-shaped with cutting knives 70 mounted at its perimeter. Each knife 70 projects radially inward in a direction generally opposite the direction of rotation of the impeller 14 within the cutting head 62, and defines a cutting edge at its radially innermost extremity. The cutting head 62 shown in FIG. 8 further comprises lower and upper support rings 72 and ring 74 to and between which the circumferentially-spaced modular units 76 are mounted. Each modular unit 76 comprises a clamping assembly 78 that secures an individual knife 70 to the modular unit 76. As more readily evident in FIGS. 9, 10, and 11, the clamping assembly 78 of each modular unit 76 includes a knife holder 80 mounted with fasteners 82 to and between a pair of mounting blocks 84, which in turn are

configured to be secured to the support rings 72 and 74 with fasteners 86. Due to the positions of the rings 72 and 74 in the cutting head 62, the mounting blocks 84 are spaced apart in an axial direction of the cutting head 62. The fasteners 86 preferably rigidly secure the mounting blocks 84 to the rings 72 and 74. The clamping assembly 78 further includes a clamp 81 mounted between the mounting blocks 84 so that the clamp 81 is positioned on the radially outward-facing side of the holder 80 to secure the knife 70 thereto. The clamp 81 is preferably pivotably mounted to the mounting blocks 84, and in the embodiment shown the fasteners 86 that secure the mounting blocks 84 to the rings 72 and 74 extend through the blocks 84 to also serve as pivot pins for the clamp 81.

**[0036]** The mounting blocks 84 are equipped with pins 88 that engage holes in the support rings 72 and 74. By appropriately locating the holes in the rings 72 and 74, the orientation of the mounting blocks 84, and consequently the knife 70, knife holder 80, and clamp 81 mounted thereto, can be used to alter the radial location of the cutting edge of the knife 70 with respect to the axis of the cutting head 62, thereby providing relatively coarse control of the thickness of the sliced food product. FIGS. 8 through 11 further show each modular unit 76 as comprising an adjustable gate 90 secured to the mounting blocks 84 with fasteners 92. A food product crosses the gate 90 prior to encountering the knife 70 mounted to the succeeding modular unit 76. To provide relatively fine control of the thickness of the sliced food product, the mounting blocks 84 are equipped with adjustment screws 94 that engage the gates 90 to alter the radial location of a trailing edge 96 (FIGS. 10 and 11) of the gate 90 relative to the cutting edge of the succeeding knife 70.

**[0037]** As more readily apparent from FIGS. 10 and 11, the knife 70 is supported by a radially outer surface of the knife holder 80, and the clamp 81 overlies the holder 80 so that the knife 70 is between the surface of the holder 80 and a radially inward surface of the clamp 81 that faces the holder 80. Alignment of the knife 70,

holder 80, and clamp 81 may be achieved with pins 98 that protrude from the knife holder 80 into complementary slots and holes in, respectively, the knife 70 and clamp 81. As evident from FIG. 11, by forcing the clamp 81 toward the holder 80, an extension 81A of the clamp 81 will apply a clamping force to the knife 70 adjacent its cutting edge. According to a preferred aspect of the invention, an eccentric cam rod 100 is used as a quick-clamping feature to apply the clamping force to the clamp 81. The cam rod 100 passes through holes 102 in the mounting blocks 84 and through complementary holes 104 on upstanding flanges 81B (FIG. 11) located at opposite ends of the clamp 81 to loosely assemble the clamp 81 to the mounting blocks 84 in combination with the pivot axis of the clamp 81 created by the fasteners 86.

**[0038]** As more readily seen in FIG. 10, the cam rod 100 comprises a camming portion 106 that engages and disengages the clamp 81 when the rod 100 is rotated between clamping and release positions, which serve to secure and release, respectively, the knife 70. The release position is depicted in FIG. 11 and results from the camming portion 106 being disengaged from the clamp 81, whereas clockwise rotation of the rod 100 (as viewed in FIG. 11) causes its camming portion 106 to eccentrically move into engagement with the surface of the clamp 81, forcing the clamp 81 into engagement with the knife 70. The force applied to the clamp 81 by the camming portion 106 can be released by rotating the cam rod 100 counterclockwise.

**[0039]** In the illustrated embodiment, the cam rod 100 is rotatably mounted to the mounting blocks 84 of the modular unit 76 as a result of its oppositely-disposed ends 105 being rotatably received in the holes 102 formed in the blocks 84, enabling the rod 100 to rotate within the holes 102 between the aforementioned clamping and release positions. The ends 105 of the cam rod 100 are preferably coaxial, whereas the camming portion 106 between the ends 105 is eccentric to the

ends 105 as well as the holes 102 in which the ends 105 are received, in other words, the axis of the camming portion 106 is parallel but not coaxial with the ends 105 of the cam rod 100. A handle 108 is provided at one end of the rod 100 to facilitate its rotation by hand. In the illustrated embodiment, the handle 108 is attached to the rod 100 so as to be disposed above the support ring 74 as seen in FIGS. 8 and 9.

**[0040]** The operation of the modular unit 76 will now be discussed in reference to FIGS. 12 through 15, which represent the knife 70 as having a straight cutting edge for producing flat slices. Knives having straight cutting edges will be referred to herein as “flat” knives. As will be subsequently discussed in reference to FIGS. 16 through 18, knives of other shapes can be used to produce sliced, strip-cut, shredded and granulated products.

**[0041]** In FIG. 12, which shows the cam rod 100 in its clamping position, the camming portion 106 is represented as having a cylindrical shape that defines an arcuate camming surface, which contacts the outer surface of the clamp 81 and forces the clamp 81 toward the knife holder 80. In the clamping position, the camming portion 106 is at its closest proximity to the knife holder 80 due to the eccentricity of the camming portion 106, with the result that the camming portion 106 applies an increasingly greater force to the clamp 81 as the camming portion 106 is rotated in the clamping direction (clockwise in FIGS. 12 through 15). As a result, the knife 70 is clamped between the knife holder 80 and clamp 81. FIG. 13 represents the clamping position of the cam rod 100 as being established by a stop 112 defined by the support ring 74. The stop 112 limits the clockwise rotation of the cam rod 100, which has a protrusion (pin) 116 that abuts the stop 112 when the cam rod 100 is in the clamping position.

**[0042]** The nonlimiting embodiment of the camming portion 106 shown in the

drawings further comprises a planar surface 110, represented as lying on a chord of the otherwise circular cross-sectional outline defined by the camming portion 106. As seen in FIG. 12, the planar surface 110 faces away from the clamp 81 when the camming portion 106 is in the clamping position. The planar surface 110 is preferably present on the camming portion 106 to provide greater clearance for slices that travel over the knife 70 and the outer surface of the clamp 81 as the slices exit the cutting head 62.

**[0043]** The result of rotating the camming portion 106 of the rod 100 to its release position (counterclockwise in FIGS. 12 and 13) is depicted in FIGS. 14 and 15, the former of which shows the camming portion 106 as being rotated out of engagement with the clamp 81 to release the force that had been applied by the rod 100 against the clamp 81. In the release position, which is represented in the drawings as the result of rotating the camming portion 106 about ninety degrees from its clamping position, the camming portion 106 is at an intermediate distance from the knife holder 80 due to its eccentricity. The camming portion 106 can be seen to have engaged the rim of the hole 104 in the clamp 81, causing the clamp 81 to pivot radially outward about its pivot (fastener 86) and disengage the knife 70. From FIG. 14, it should be apparent that rotating the camming portion 106 about 180 degrees from the clamping position would result in the camming portion 106 being at its greatest distance from the knife holder 80. However, the rotation of the cam rod 100 is limited by a stop 114 defined by the support ring 74, which the rod protrusion 116 abuts when the cam rod 100 is in the release position. Even so, the clamping force applied by the camming portion 106 has been sufficiently released to enable the clamp 81 to be loosened and raised off the surface of the knife 70 as illustrated in FIG. 14. Because the knife 70 is no longer clamped between the knife holder 80 and clamp 81, the knife 70 can be removed from the modular unit 76, for example, through an opening 117 in the upper ring 74 seen in FIG. 15. From FIGS. 12 through 15, it can be appreciated that the flat knife 70 can be quickly secured

and released by rotating the rod 100 between its clamping and release positions.

**[0044]** FIGS. 16 through 18 represent how knives having shapes other than flat can be utilized with the modular unit 76 to produce other than flat sliced products. FIG. 16 represents a nonlimiting example of a “shaped” knife 70 having a cutting edge that defines a periodic pattern of peaks and valleys when viewed edgewise, and FIG. 17 shows the shaped knife 70 of FIG. 16 installed in the modular unit 76. As evident from FIG. 17, the shaped knife 70 has a greater effective thickness than the flat knife 70 of FIGS. 12 through 15, to the extent that the release position of the clamp 81 depicted in FIG. 14 may not be sufficient to release the shaped knife 70. This issue can be addressed by modifying the placement of the stop 114 that determines the release position of the cam rod 100. In particular, FIGS. 17 and 18 represent the result of rotating the camming portion 106 beyond the ninety-degree counterclockwise rotation permitted by the stop 114 of FIGS. 13 and 15. As depicted in FIGS. 17 and 18, the cam rod 100 has been rotated about 180 degrees from the clamping position, resulting in its camming portion 106 being at its greatest distance from the knife holder 80, which as evident from FIG. 17 is sufficient to enable the clamp 81 to release the shaped knife 70. Because the knife 70 is no longer clamped between the knife holder 80 and clamp 81, the knife 70 can be removed from the modular unit 76, for example, through the opening 117 in the upper ring 74 as seen in FIG. 18.

**[0045]** FIGS. 19 and 20 provide two perspective views to further illustrate different locations of the stop 114 resulting from the support ring 74 of the cutting head 62 being configured for clamping either flat knives 70 (FIG. 19) or shaped knives 70 (FIG. 20). From FIGS. 12 through 20, it should be evident that the extent to which the cam rod 100 is able to accommodate flat and shaped knives 70 can be tailored by the location of the stop 114, without necessitating modifications to the modular unit 76 itself. For example, the support ring 74 may be replaced or its stop

114 relocated or otherwise modified in an appropriate manner. However, a more optimal clamping effect can be achieved by appropriately shaping the knife holder 80 and clamp 81 to be complementary to the shape of the knife 70. The modular unit 76 is able to address this issue as a result of its modular construction, which permits holders 80 and clamps 81 of various configurations to be assembled to the mounting blocks 84. This preferred aspect of the invention is illustrated in FIGS. 21, 22 and 23. FIG. 21 represents the mounting blocks 84 and cam rod 100 as a subassembly 118 of the modular unit 76. In FIG. 22, a flat knife 70 and a knife holder 80 and clamp 81 specifically configured for use with the flat knife 70 (together constituting the clamping assembly 78) have been assembled with the subassembly 118, whereas FIG. 23 represents the same subassembly 118 as having been assembled with a different clamping assembly 78 comprising a shaped knife 70 and a knife holder 80 and clamp 81 specifically configured to have periodic patterns of peaks and valleys that are complementary to peaks and valleys of the shaped knife 70.

**[0046]** FIGS. 24 and 25 further illustrate the versatility of the modular unit 76 in terms of its adaptability for use with support rings 72 and 74 of various configurations and sizes (diameters). In particular, the placements of the mounting blocks 84 of the units 76 differ with respect to the support rings 72 in FIGS. 24 and 25. The trailing edges 96 of the gates 90 in FIG. 25 create larger gate openings 120 with their respective succeeding knives 70, causing the knives 70 in FIG. 25 to produce much thicker slices than what is produced with the identical units 76 shown in FIG. 24.

**[0047]** FIGS. 26 through 33 contain various views representing a modular unit in accordance with another nonlimiting embodiment of the invention. For convenience, identical reference numerals are used in FIGS. 26 through 33 to denote the same or functionally related elements described for the embodiments

of the modular unit 76 of FIGS. 8 through 25. In view of similarities between the embodiments, the following discussion of FIGS. 26 through 33 will focus primarily on aspects of the embodiment shown therein that differ from the modular units 76 of FIGS. 8 through 25 in some notable or significant manner. Other aspects of the embodiment of FIGS. 26 through 33 that are not discussed in any detail can be, in terms of structure, function, materials, etc., essentially as was described for the modular units 76 of FIGS. 8 through 25.

**[0048]** The modular unit 76 of FIGS. 26 through 33 includes means for inhibiting deflection of the camming portion 106 away from the knife holder 80 when the cam rod 100 is in the clamping position. In the embodiment shown in FIGS. 26 through 33, the deflection inhibiting means comprises complementary features 122 that is configured to] that minimize the extent to which the camming portion 106 of the cam rod 100 can deflect when engaged with and applying a clamping force to the clamp 81. In doing so, the complementary features 122 may also be capable of promoting a more uniform clamping force applied by the clamp 81 along the length of the knife 70. Deflection of the camming portion 106 is limited by interlocking a latch 124 carried on the camming portion 106 with a catch 126 provided by the knife holder 80. In the nonlimiting embodiment shown in the drawings, the latch 124 is depicted as a pin or bolt threaded into or otherwise secured to the camming portion 106, and the catch 126 is depicted as a slot defined in the knife holder 80, though it is foreseeable that other complementary means could be employed for interlocking the camming portion 106 with the knife holder 80 to prevent the camming portion 106 from deflecting away from the camming portion 106, and such other means are within the scope of the invention.

**[0049]** FIG. 26 shows the knife 70, knife holder 80, and clamp 81 installed on the modular unit 76 and the cam rod 100 in its clamping position. FIG. 27 is an identical view but with the clamp 81 removed to more fully reveal the knife holder 80. FIG.

28 shows the modular unit 76 of FIG. 27 from a different angle, and FIG. 29 is an identical view to FIG. 28 but shows the cam rod 100 in its release position. The latch 124 extends radially from the camming portion 106 of the rod 100 so that rotating the cam rod 100 between its clamping position (FIGS. 26-28) and its release position (FIG. 29), causes the latch 124 to rotate into (FIGS. 30, 32, and 33) and out of (FIG. 31) engagement with the catch 126, respectively.

**[0050]** The embodiment of the latch 124 represented in FIGS. 26 through 33 comprises a shank 124a and a head 124b that is wider than the shank 124a. FIGS. 30 through 33 show that the latch 124 engages with the catch 126 as a result of the shank 124a and head 124b of the latch 124 initially entering and traveling through the catch 126, and the shank 124a subsequently entering a restricted (narrower) portion 126a of the catch 126 such that the head 124b engages a shoulder 126b formed by the restricted portion 126a opposite the camming portion 106. To facilitate this action, the entrance 126c to the restricted portion 126a of the catch 126 can be seen in FIGS. 30 and 31 to be sloped and more preferably rounded to have a radius of curvature, creating a ramp that approximates the arcuate path that the latch head 124b travels. Because the clamp 81 overlays the holder 80, a complementary slot 128 is provided in the clamp 81 and aligned with the catch 126 in the holder 80 so that the latch 124 is able to freely enter the catch 126. To maximize its effectiveness, the latch 124 is preferably located roughly at the center of the length of the camming portion 106 between the mounting blocks 84, though such a location is not required. It is also within the scope of the invention to utilize any number of complementary latches 124 and catches 126 along the lengths of the camming portion 106 and knife holder 80.

**[0051]** The drawings show the catch 126 as being provided as a removable and replaceable insert 130 installed in the knife holder 80, so that the physical properties and dimensions of the catch 126 can be tailored for interacting with the latch 124.

The insert 130 is represented as being removably attached with threaded fasteners 132, though other means for securing the insert 130 to the knife holder 80 are also within the scope of the invention. As evident from comparing FIGS. 30 and 31, the eccentricity of the camming portion 106 and the dimensions of the latch 124 and catch 126 (and insert 130 if employed) are coordinated to provide the latching action that enables the complementary features 122 to inhibit if not eliminate any deflection of the camming portion 106 by the process of engaging and clamping the clamp 81 between the camming portion 106 and knife holder 80. The dimensional cooperation of the camming portion 106 and catch 126 can be tailored by altering the dimensions of the latch 124, for example, by adjusting the extent to which the latch 124 is threaded into the camming portion 106.

**[0052]** While the invention has been described in terms of specific or particular embodiments, it should be apparent that alternatives could be adopted by one skilled in the art. For example, the machine 10, cutting head 62, impeller 14, modular units 76, and their respective components could differ in appearance and construction from the embodiments described herein and shown in the drawings, functions of certain components could be performed by components of different construction but capable of a similar (though not necessarily equivalent) function, and various materials could be used in the fabrication of the machine 10, cutting head 62, impeller 14, modular units 76, and their respective components. As such, it should be understood that the above detailed description is intended to describe the particular embodiments represented in the drawings and certain but not necessarily all features and aspects thereof, and to identify certain but not necessarily all alternatives to the represented embodiments and described features and aspects. As a nonlimiting example, the invention encompasses additional or alternative embodiments in which one or more features or aspects of a particular embodiment could be eliminated or two or more features or aspects of different embodiments could be combined. Accordingly, it should be understood that the

invention is not necessarily limited to any embodiment described herein or illustrated in the drawings. It should also be understood that the phraseology and terminology employed above are for the purpose of describing the illustrated embodiment, and do not necessarily serve as limitations to the scope of the invention. Therefore, the scope of the invention is to be limited only by the following claims.

WHAT IS CLAIMED IS:

1. A modular unit for securing a knife to a cutting head of a slicing machine, the modular unit comprising:

mounting blocks that are spaced apart in an axial direction; and

a clamping assembly assembled with the mounting blocks so as to be between the mounting blocks, the clamping assembly comprising:

a knife holder;

a knife supported by the knife holder;

a clamp overlying the knife holder so that the knife is between the knife holder and the clamp;

a cam rod that secures the clamp to the knife holder and clamps the knife therebetween, the cam rod having oppositely-disposed ends rotatably coupled with the mounting blocks and a camming portion between the oppositely-disposed ends and arranged for contacting the clamp, the cam rod being rotatable to have a clamping position and a release position, the camming portion applying a force that clamps the clamp against the knife holder when the cam rod is in the clamping position, the camming portion releasing the force against the clamp when the cam rod is in the release position; and

means for inhibiting deflection of the camming portion away from the knife holder when the cam rod is in the clamping position, the deflection inhibiting means comprising a latch extending from the camming portion and a catch on the knife holder.

2. The modular unit according to claim 1, wherein the latch is threaded into the camming portion.

3. The modular unit according to claim 1, wherein the catch comprises a slot in the knife holder that defines a shoulder, and the latch comprises a shank configured to pass through the slot and a head configured to engage the shoulder.

4. The modular unit according to claim 3, wherein the shoulder of the slot is defined by a narrower portion of the slot.

5. The modular unit according to claim 4, wherein the narrower portion of the slot has an entrance having a radius of curvature that approximates an arcuate path that the head travels.

6. The modular unit according to claim 3, wherein the clamp has a slot that is complementary to the slot in the knife holder.

7. The modular unit according to claim 3, further comprising a removable insert that defines the slot in the knife holder.

8. The modular unit according to claim 1, wherein the camming portion of the cam rod comprises a cylindrical portion of the cam rod that contacts the clamp in the clamping position and disengages the clamp in the release position.

9. The modular unit according to claim 1, wherein the cam rod is rotatably and eccentrically coupled to the mounting blocks, the camming portion is closer to the knife holder in the clamping position, and the camming portion is farther from the knife holder in the release position.

10. A slicing machine comprising a cutting head and a modular unit mounted to the cutting head, the modular unit comprising:

mounting blocks that are spaced apart in an axial direction of the cutting head; and

a clamping assembly assembled with the mounting blocks so as to be between the mounting blocks, the clamping assembly comprising:

a knife holder;

a knife supported by the knife holder;

a clamp overlying the knife holder so that the knife is between the

knife holder and the clamp;

a cam rod that secures the clamp to the knife holder and clamps the knife therebetween, the cam rod having oppositely-disposed ends rotatably coupled with the mounting blocks and a camming portion between the oppositely-disposed ends and arranged for contacting the clamp, the cam rod being rotatable to have a clamping position and a release position, the camming portion applying a force that clamps the clamp against the knife holder when the cam rod is in the clamping position, the camming portion releasing the force against the clamp when the cam rod is in the release position; and

means for inhibiting deflection of the camming portion away from the knife holder when the cam rod is in the clamping position, the deflection inhibiting means comprising a latch extending from the camming portion and a catch on the knife holder.

11. The slicing machine according to claim 10, wherein at least portions of the clamping assembly are removable from the cutting head by disassembling the clamping assembly from the mounting blocks without removing the mounting blocks from the cutting head.

12. The slicing machine according to claim 10, wherein the catch comprises a slot in the knife holder that defines a shoulder, and the latch comprises a shank configured to pass through the slot and a head configured to engage the shoulder.

13. The slicing machine according to claim 12, wherein the shoulder of the slot is defined by a narrower portion of the slot.

14. The slicing machine according to claim 13, wherein the narrower portion of the slot has an entrance having a radius of curvature that approximates an arcuate path that the head travels.

15. The slicing machine according to claim 12, wherein the clamp has a slot that is complementary to the slot in the knife holder.

16. The slicing machine according to claim 12, further comprising a removable insert that defines the slot in the knife holder.

17. The slicing machine according to claim 10, wherein the cam rod is rotatably and eccentrically coupled to the mounting blocks, the camming portion is closer to the knife holder in the clamping position, and the camming portion is farther from the knife holder in the release position.

18. The slicing machine according to claim 10, further comprising an adjustable gate that is assembled with the mounting blocks so as to be between the mounting blocks, the adjustable gate being adjustably secured to the mounting blocks so as to define a trailing edge having an adjustable radial location.

19. The slicing machine according to claim 10, wherein the cutting head comprises support rings that are spaced apart in the axial direction of the cutting head, the modular unit is mounted to and between the support rings, a first of the mounting blocks is secured to a first of the support rings, and a second of the mounting blocks is secured to a second of the support rings.

20. A slicing machine comprising a cutting head and a modular unit mounted to the cutting head, the modular unit comprising:

mounting blocks that are spaced apart in an axial direction of the cutting head; and

a clamping assembly assembled with the mounting blocks so as to be between the mounting blocks, the clamping assembly comprising:

a knife holder;

a knife supported by the knife holder;

a clamp overlying the knife holder so that the knife is between the knife holder and the clamp;

a cam rod that secures the clamp to the knife holder and clamps the knife therebetween, the cam rod having oppositely-disposed ends rotatably coupled with the mounting blocks and a camming portion between the oppositely-disposed ends and arranged for contacting the clamp, the cam rod being rotatable to have a clamping position and a release position, the camming portion applying a force that clamps the clamp against the knife holder when the cam rod is in the clamping position, the camming portion releasing the force against the clamp when the cam rod is in the release position; and

means for inhibiting deflection of the camming portion away from the knife holder when the cam rod is in the clamping position;

wherein the cutting head comprises support rings that are spaced apart in the axial direction of the cutting head, the modular unit is mounted to and between the support rings, a first of the mounting blocks is secured to a first of the support rings, and a second of the mounting blocks is secured to a second of the support rings;

wherein the slicing machine further comprises a first stop that prevents rotation of the cam rod beyond the clamping position and a second stop that prevents rotation of the cam rod beyond the release position.

21. The slicing machine according to claim 20, wherein the first and second stops are defined by the first support ring.

22. A method of modifying the slicing machine of claim 21 by replacing the first support ring with a third support ring, wherein the location of the second stop of the first support ring is different than the location of the second stop of the third support ring so that the release positions established by the first and third support rings are different.

23. The method according to claim 22, wherein the release position established by the third support ring enables the clamping and releasing of a thicker knife than possible with the first support ring.

24. The method according to claim 23, wherein the thicker knife is a shaped knife having a periodic pattern of peaks and valleys.

25. A method of modifying the slicing machine of claim 19 by disassembling the clamping assembly from the mounting blocks and assembling a second clamping assembly to the mounting blocks, the second clamping assembly comprising a second knife holder and a second clamp that each have a periodic pattern of peaks and valleys that is complementary to the shaped knife.

26. The slicing machine according to claim 10, wherein the cutting head is an annular-shaped cutting head, the slicing machine further comprises an impeller coaxially mounted within the cutting head for rotation about an axis of the cutting head in a rotational direction relative to the cutting head, the impeller has means for delivering food products radially outward toward the cutting head, and the knife extends radially inward toward the impeller in a direction opposite the rotational direction of the impeller.

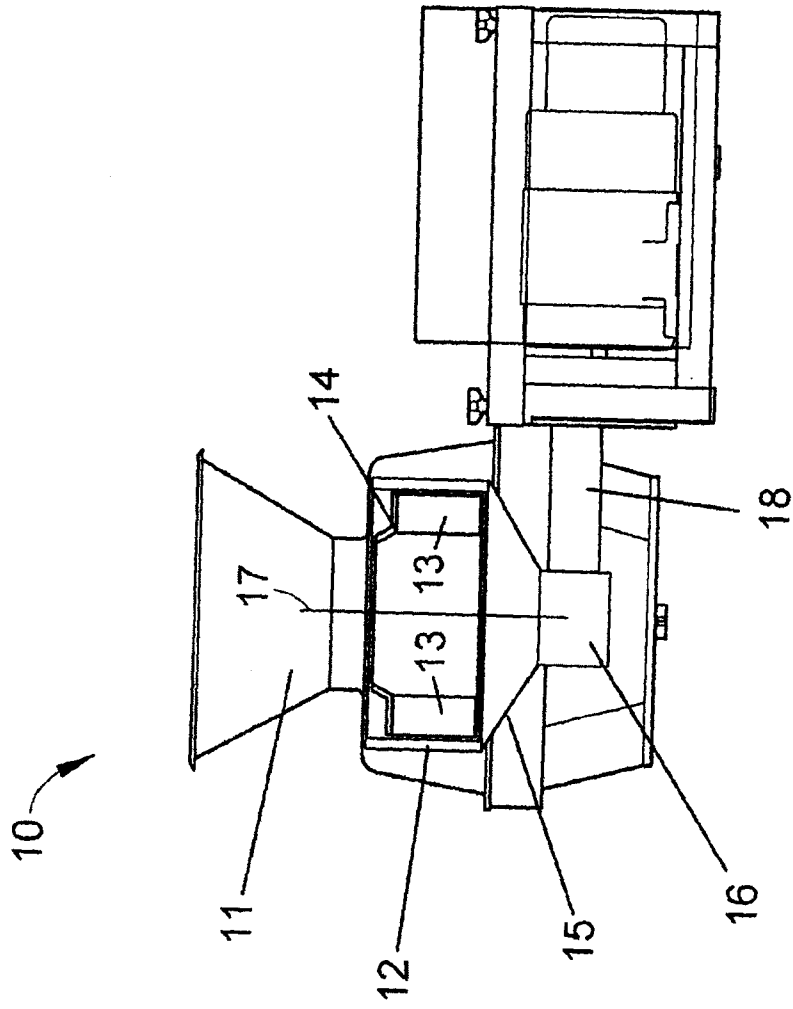
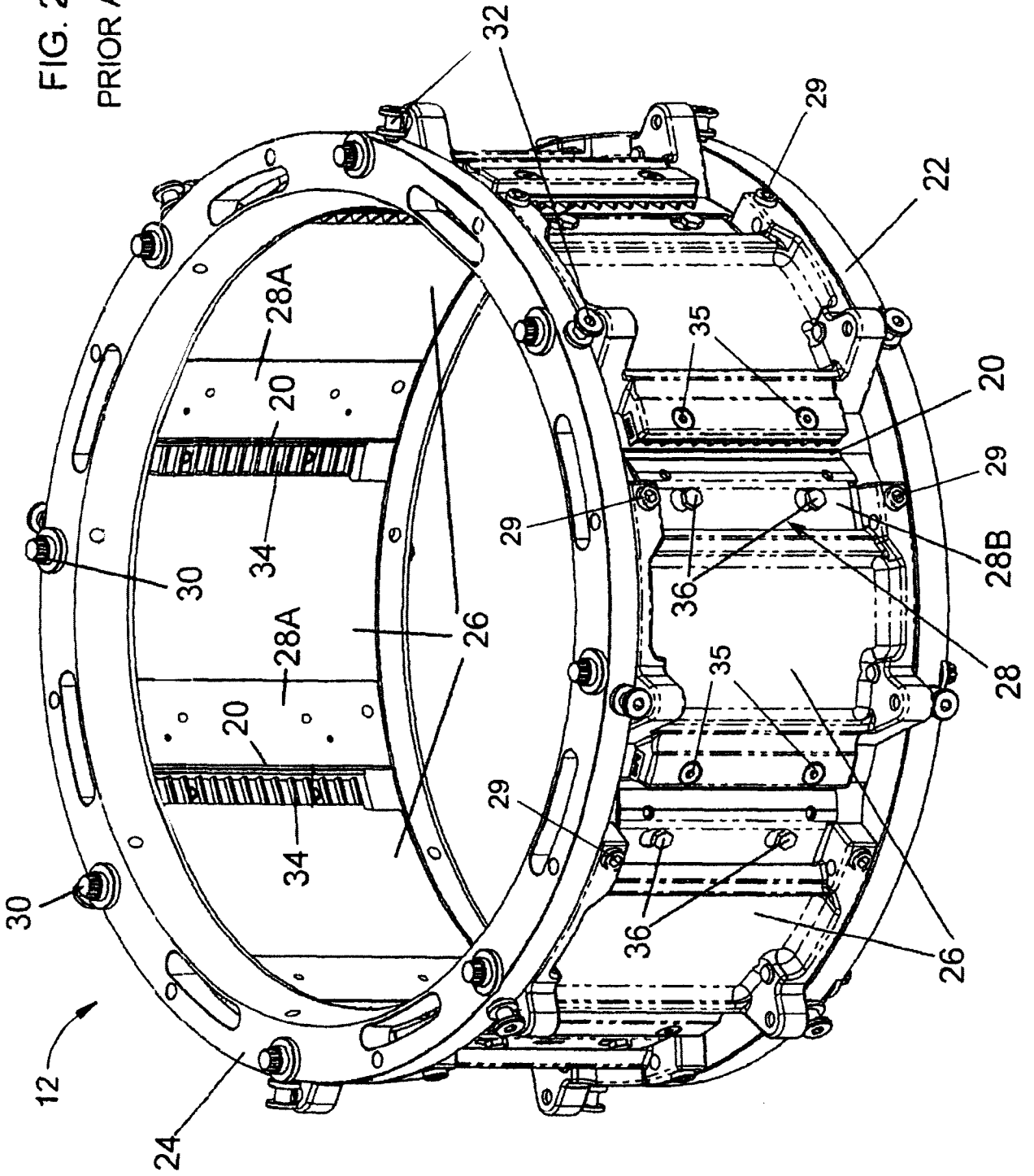

FIG. 1  
PRIOR ART

FIG. 2  
PRIOR ART



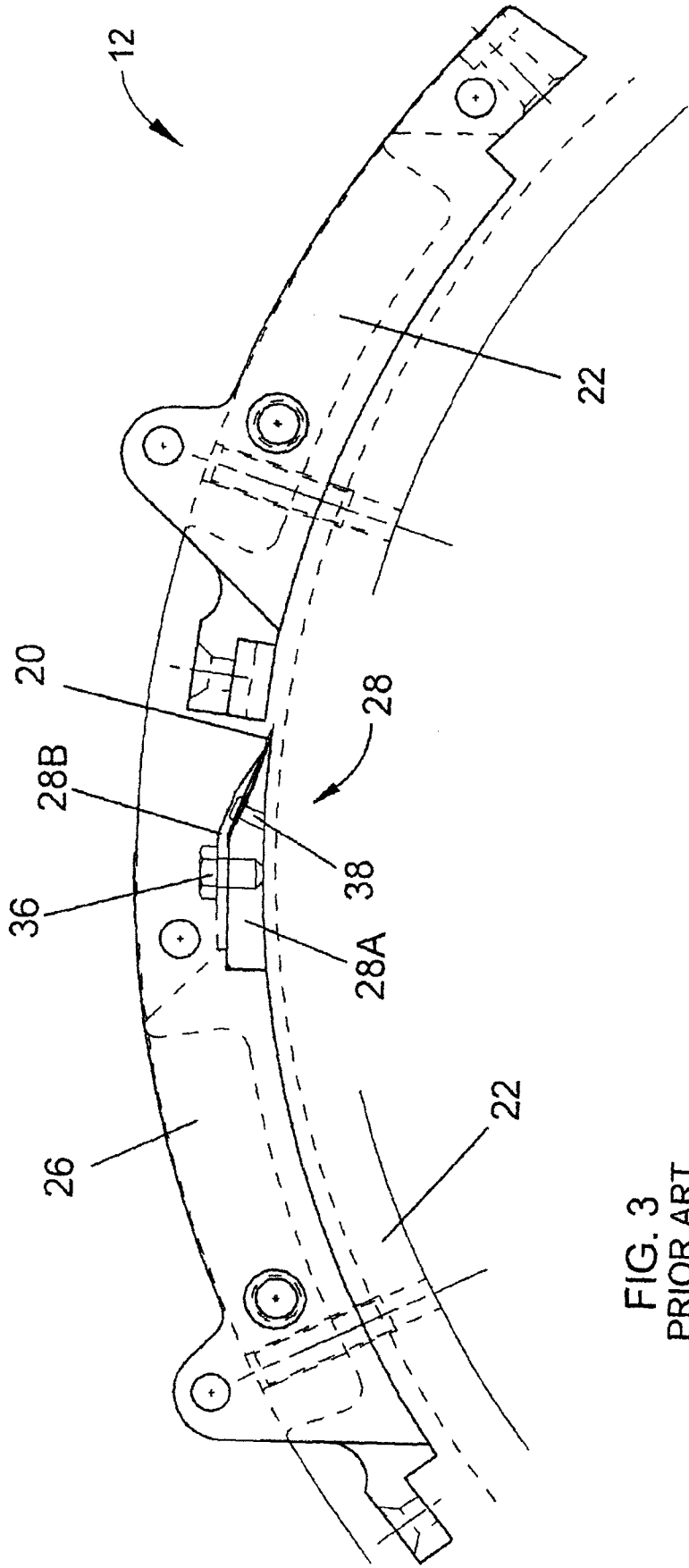

FIG. 3  
PRIOR ART

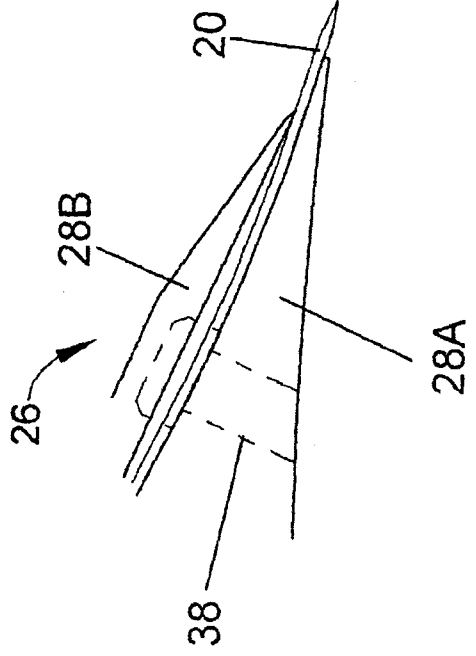

FIG. 4  
PRIOR ART

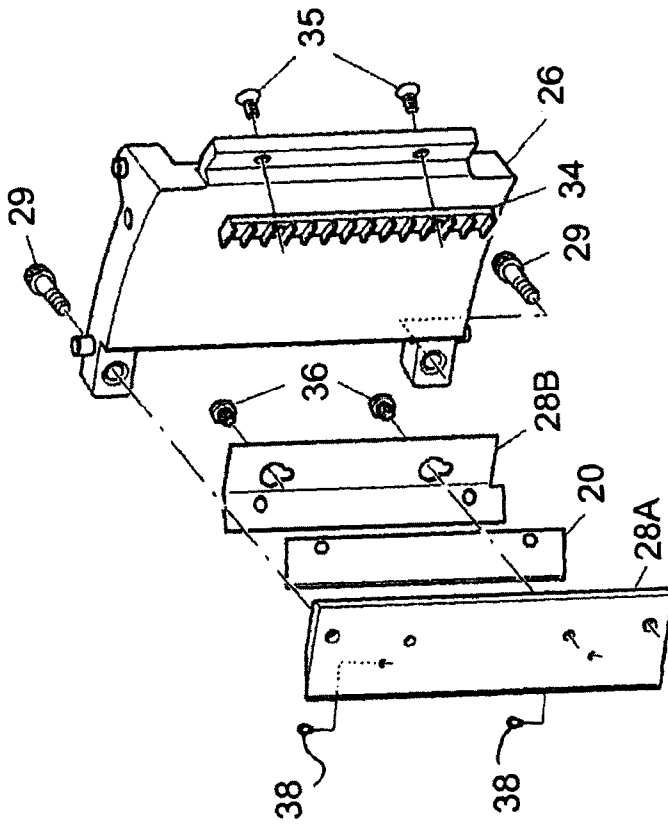

FIG. 5  
PRIOR ART

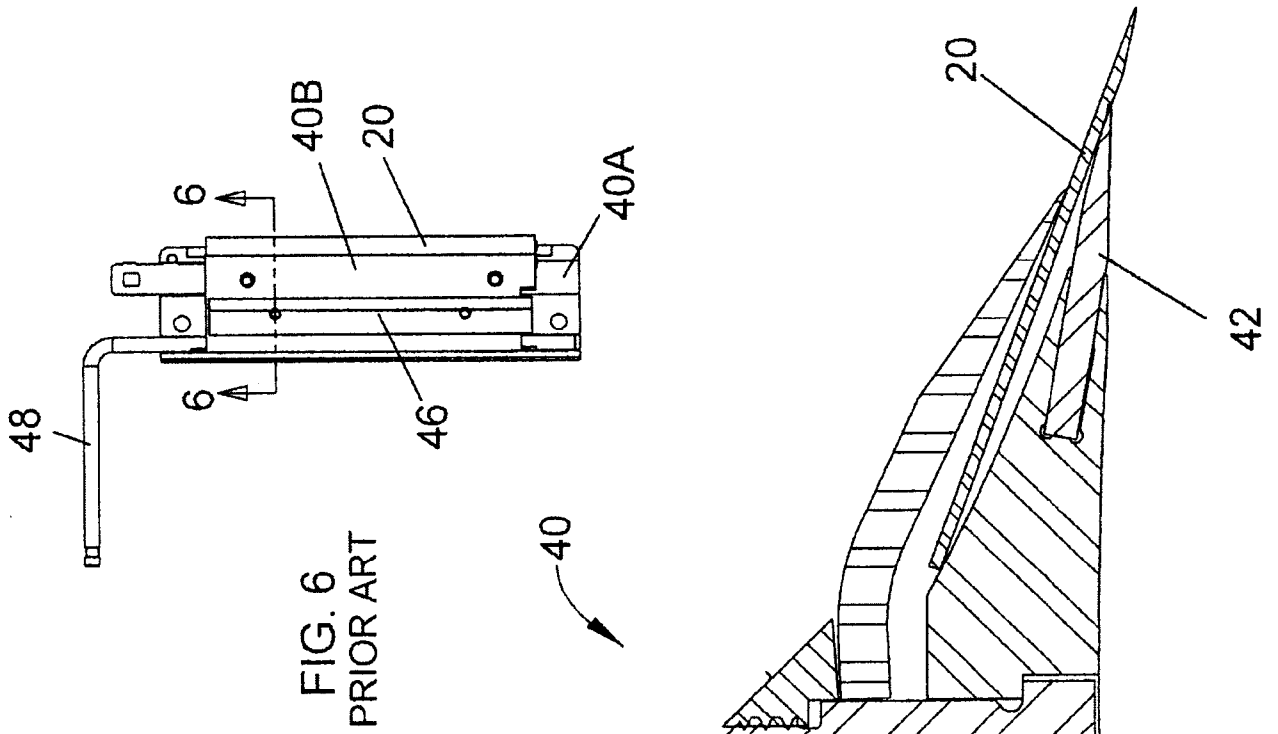
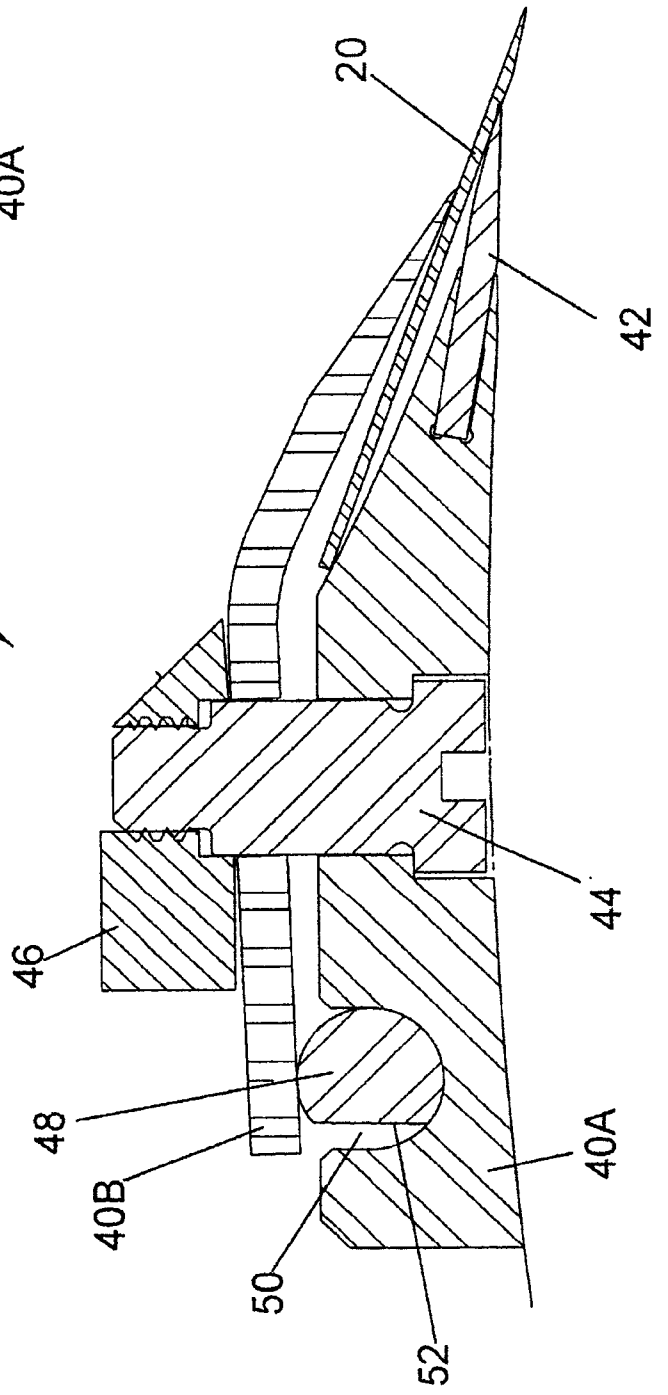

FIG. 7  
PRIOR ART



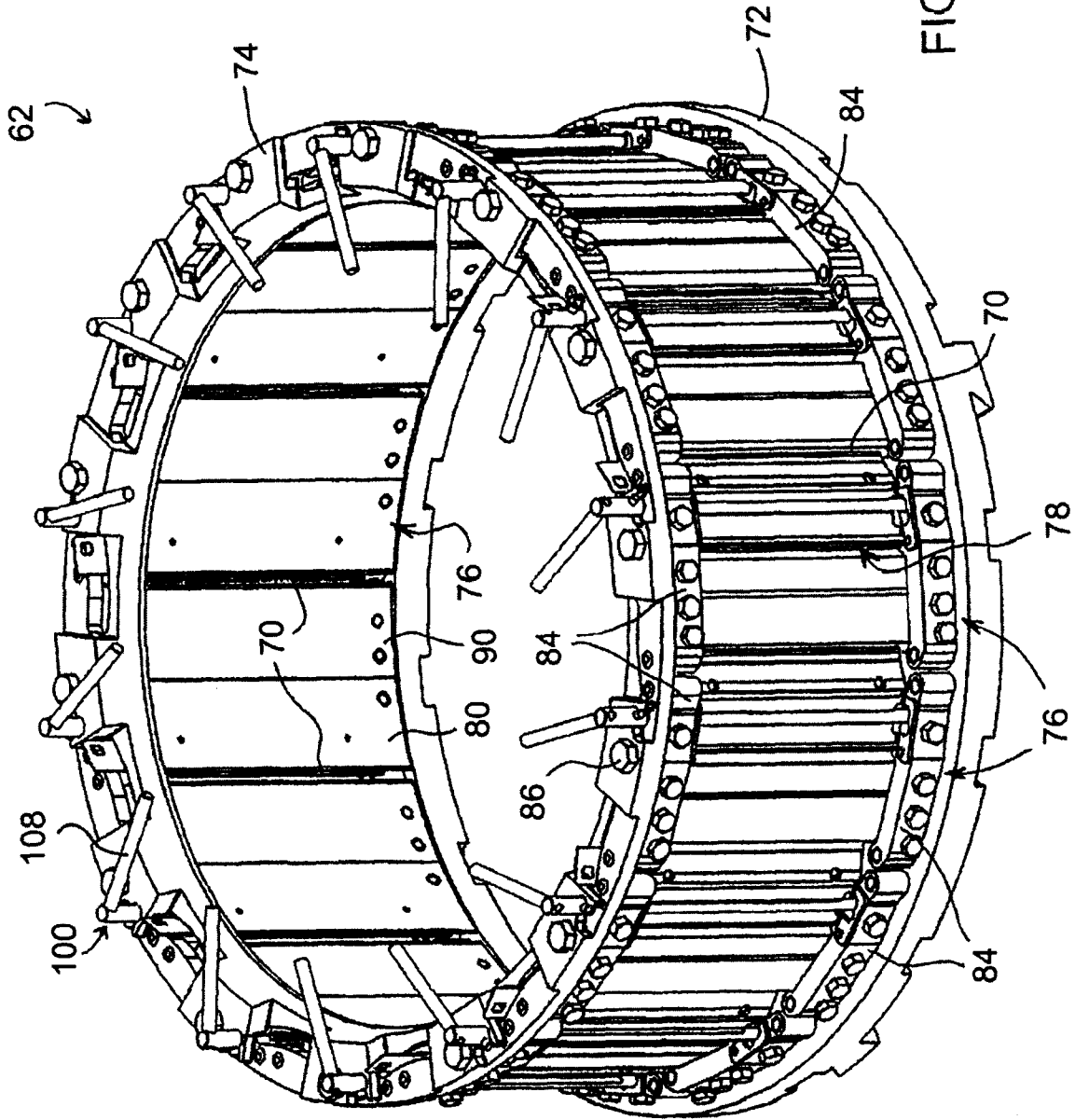

FIG. 8

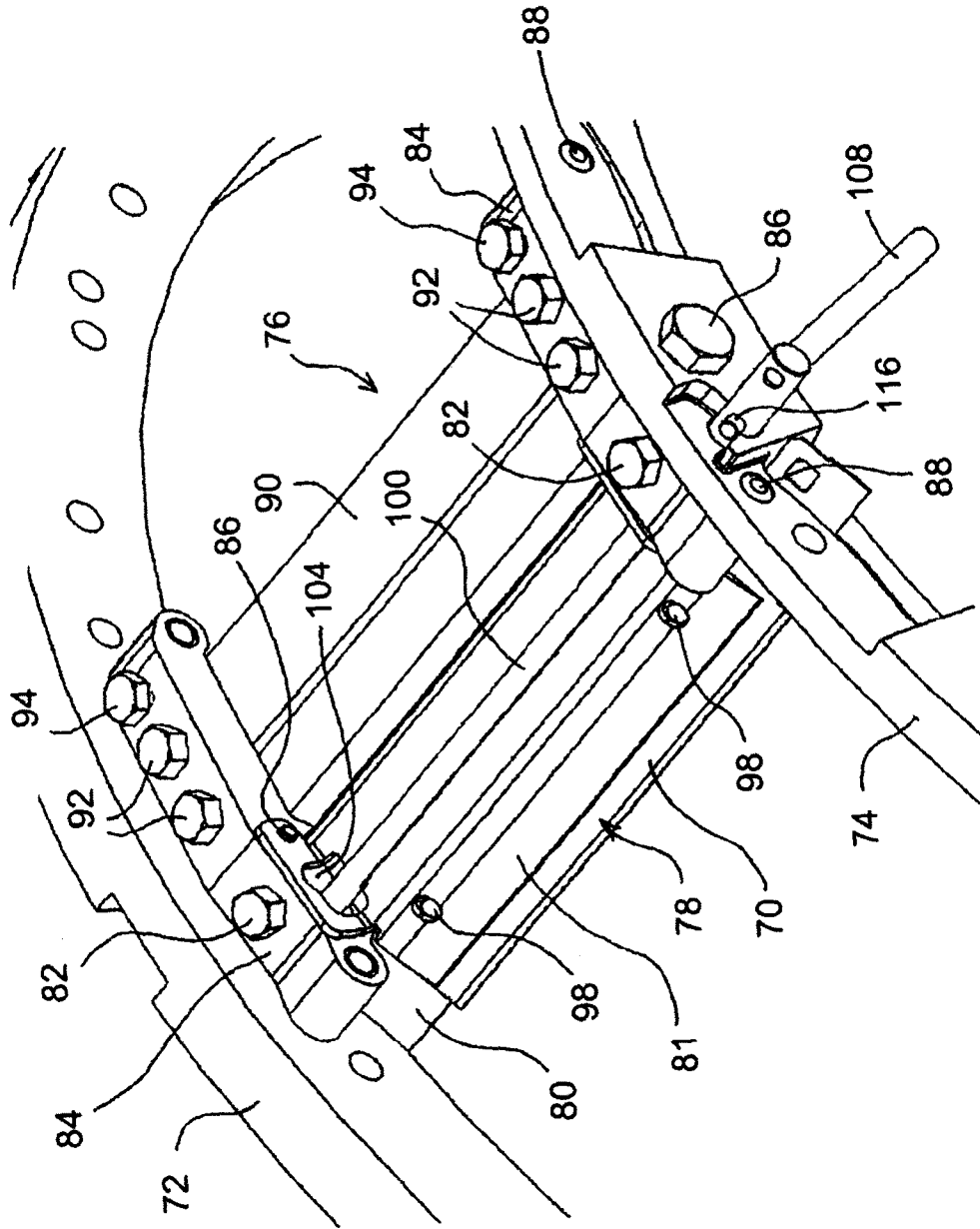
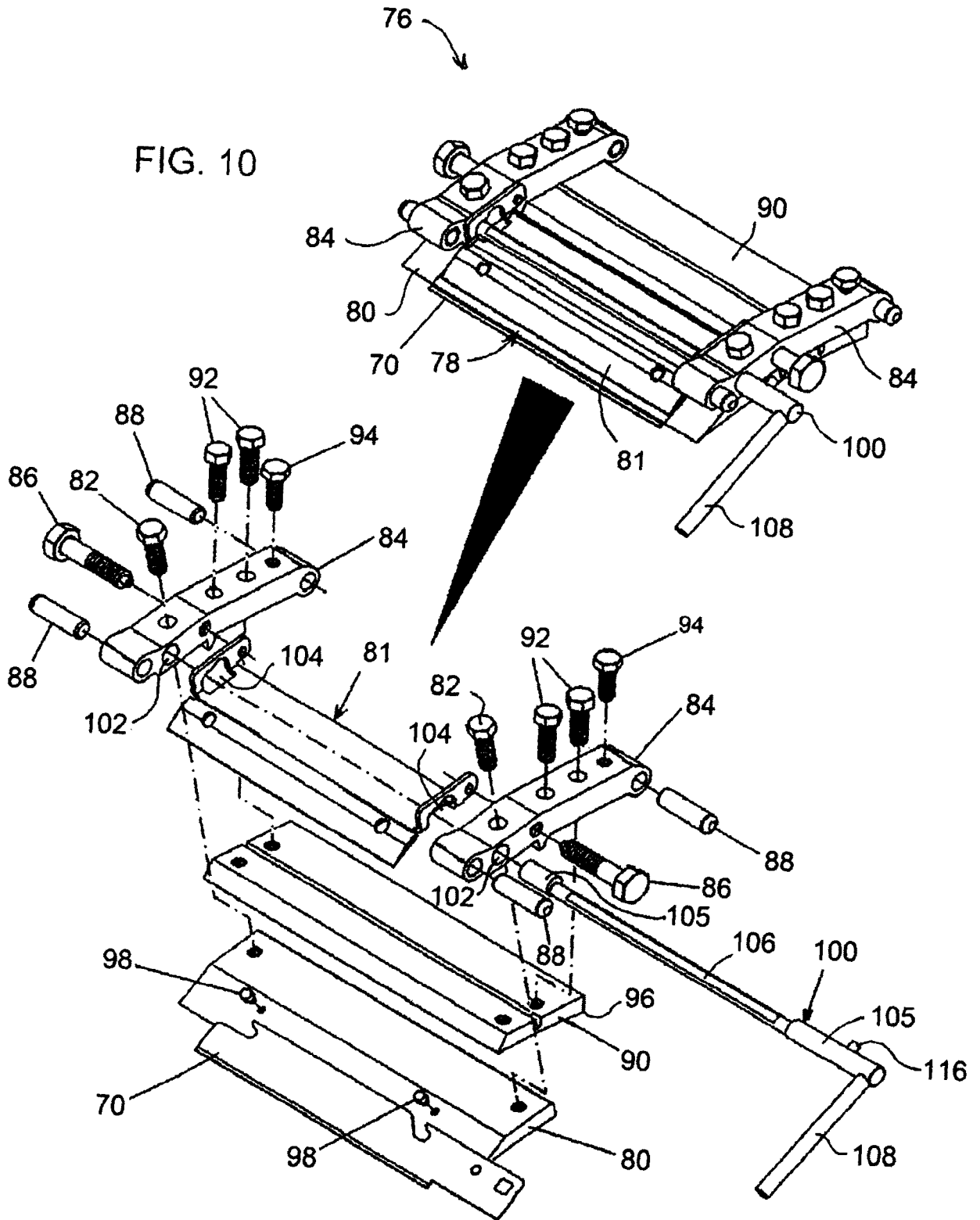

FIG. 9

FIG. 10



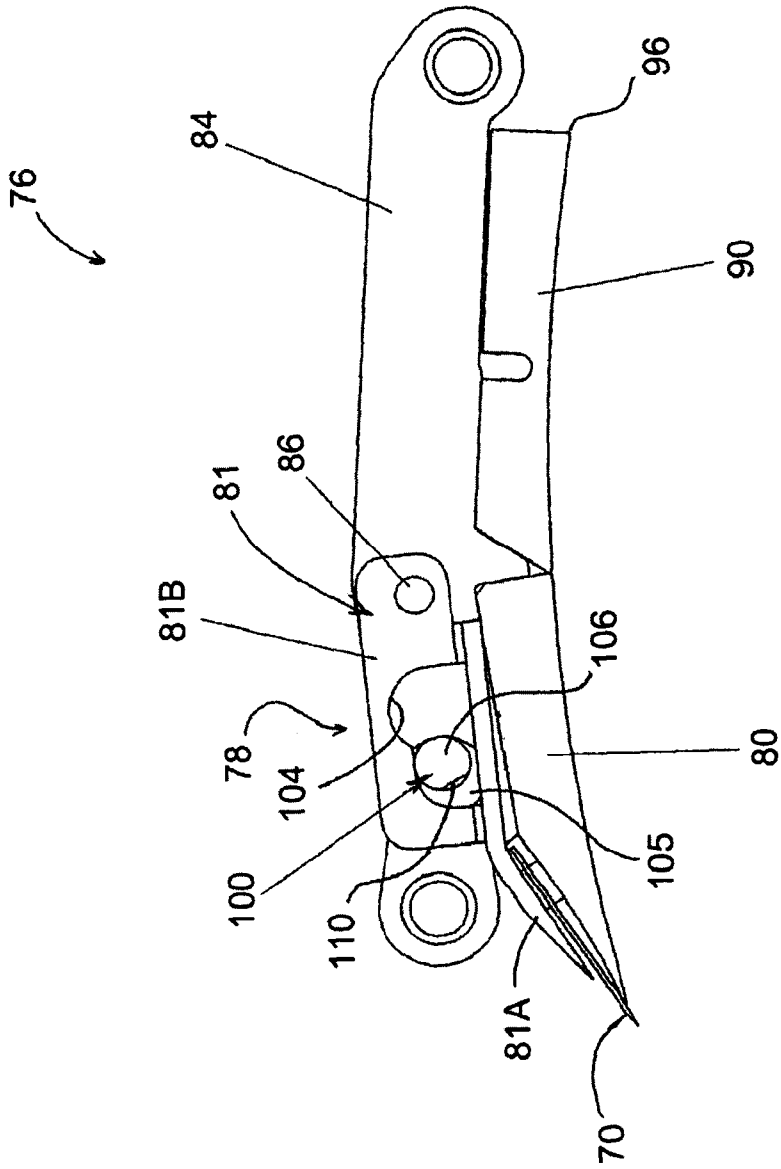

FIG. 11

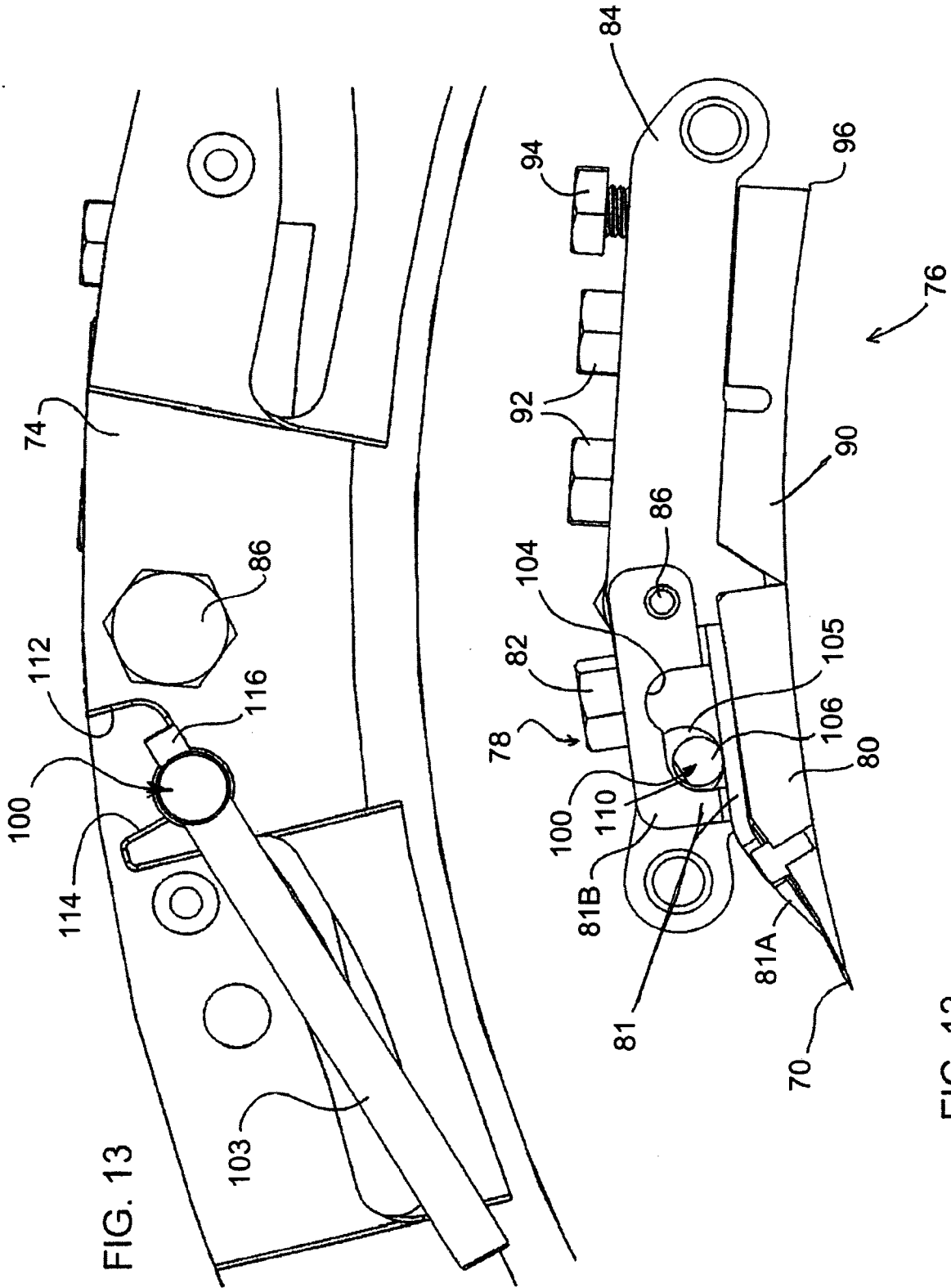

FIG. 13

FIG. 12

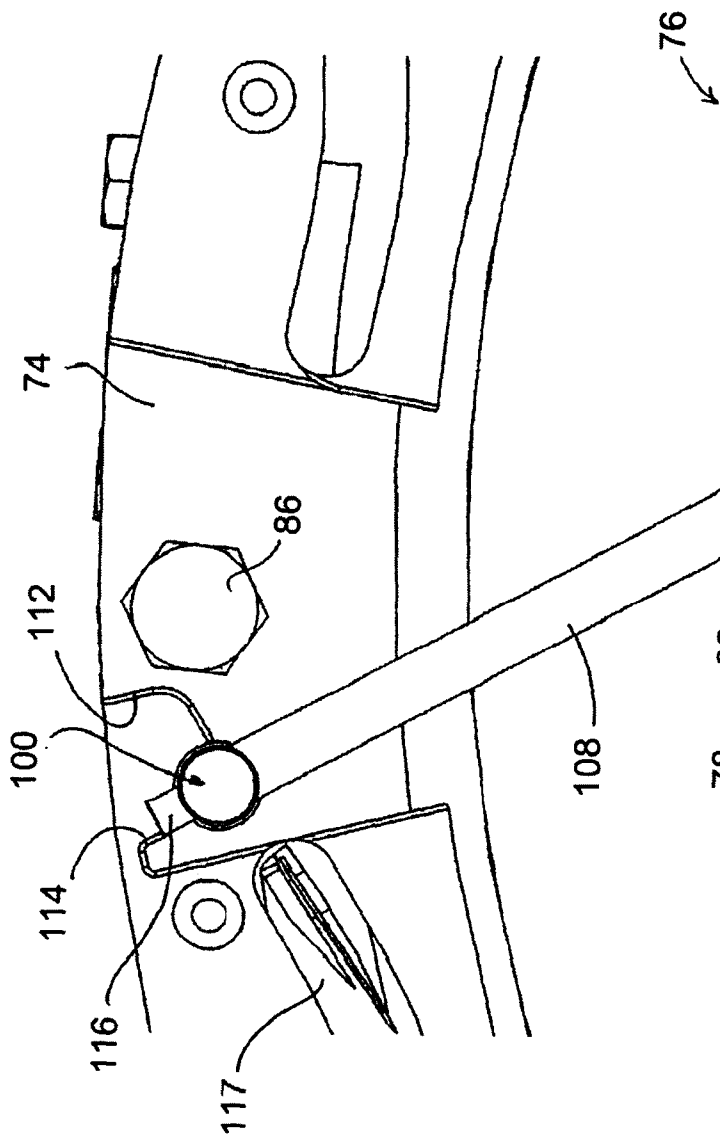

FIG. 15

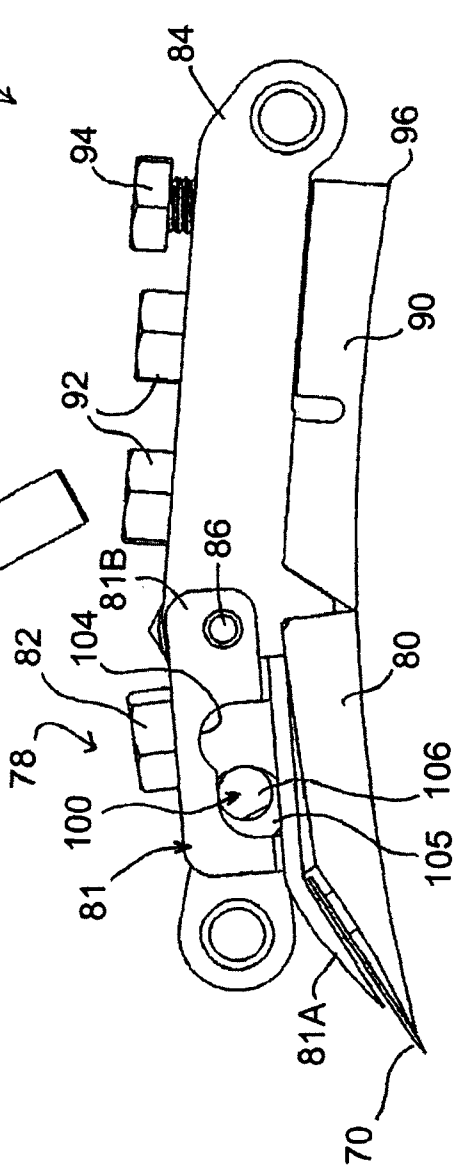
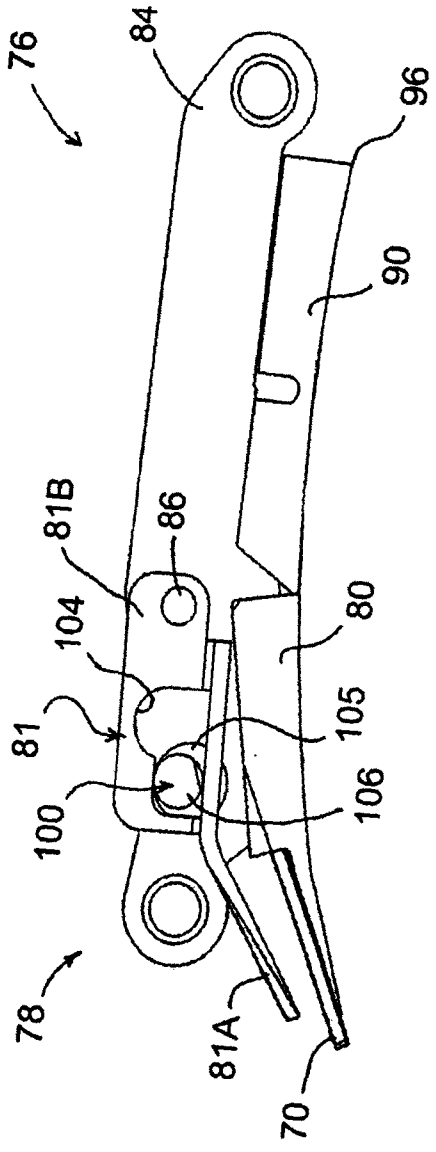
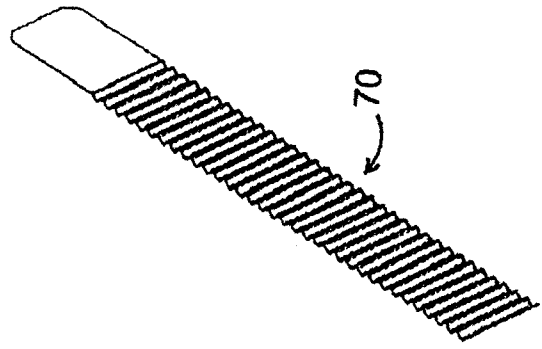
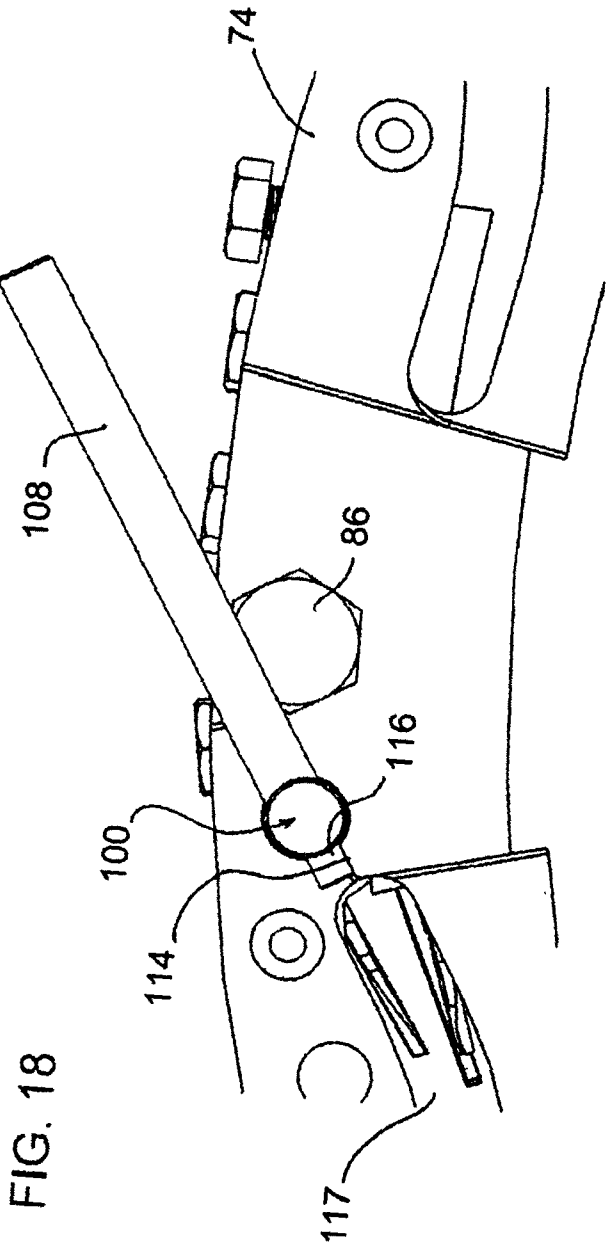
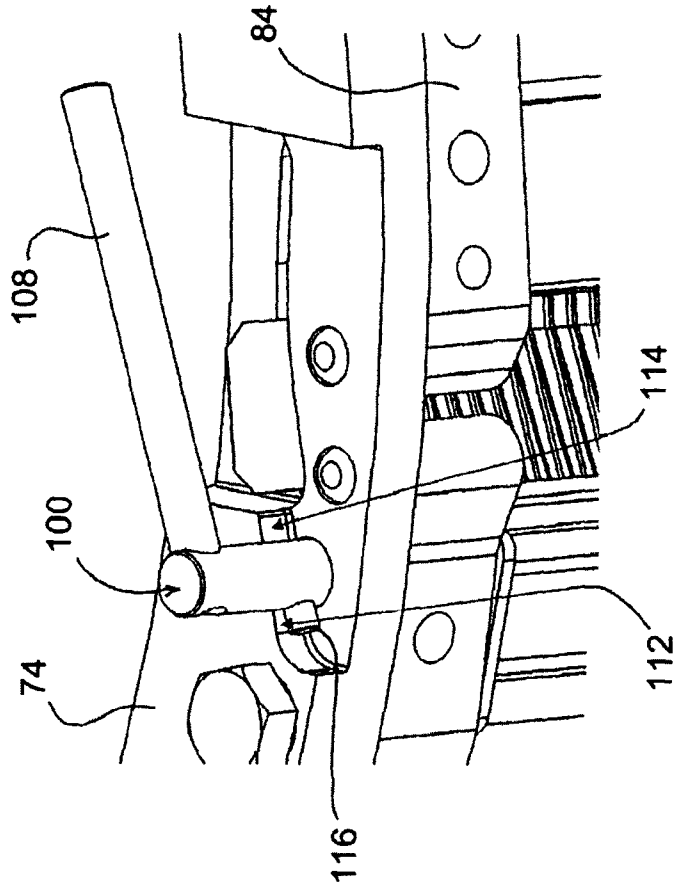
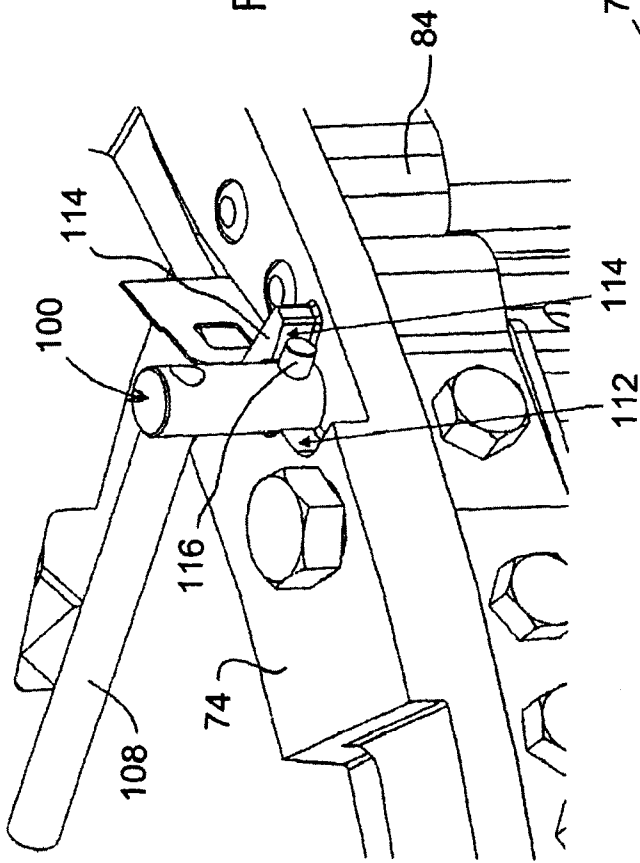

FIG. 14





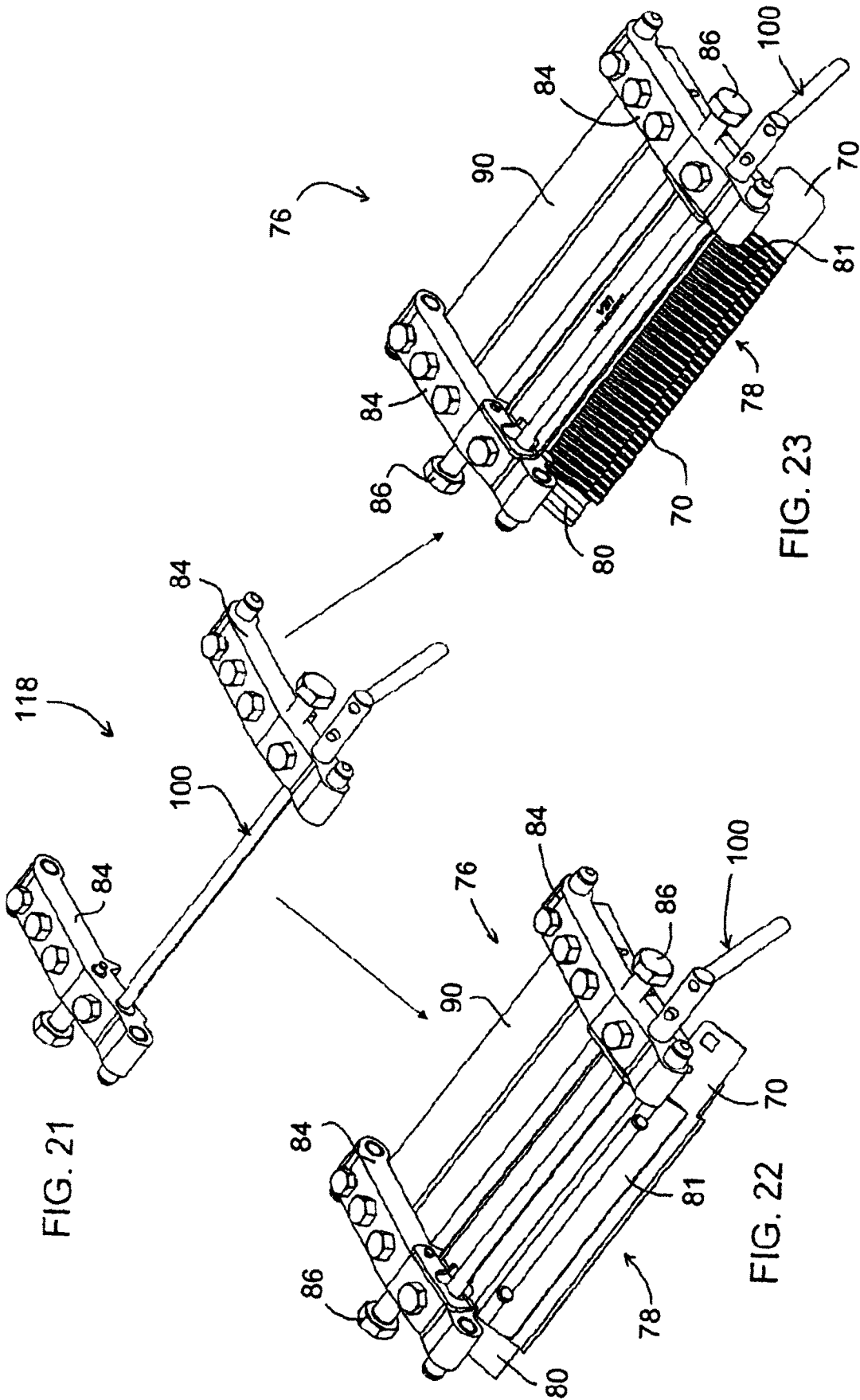

FIG. 21

FIG. 23

FIG. 22

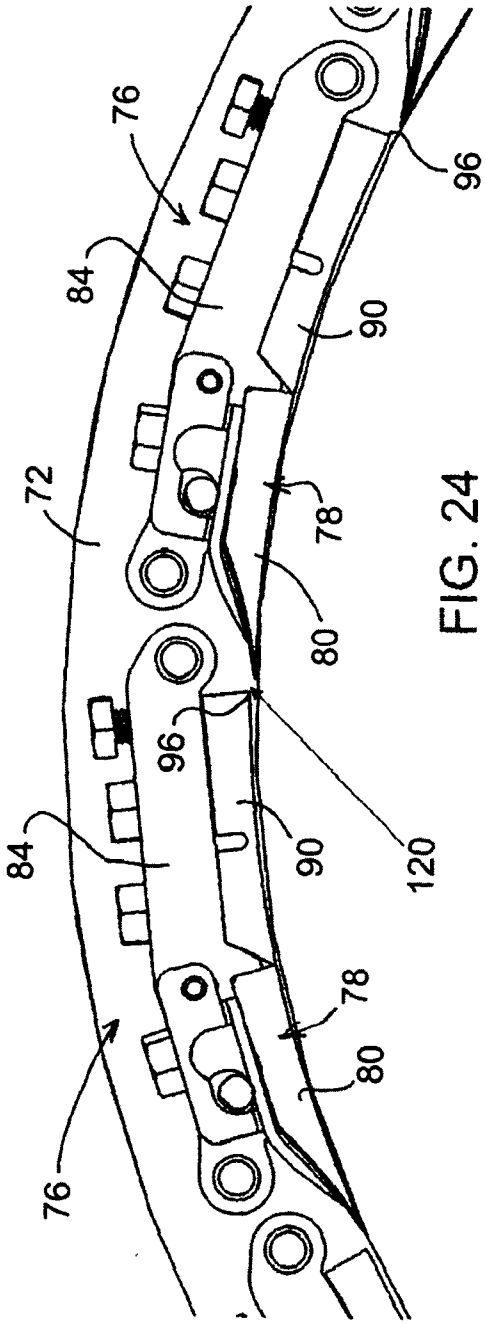

FIG. 24

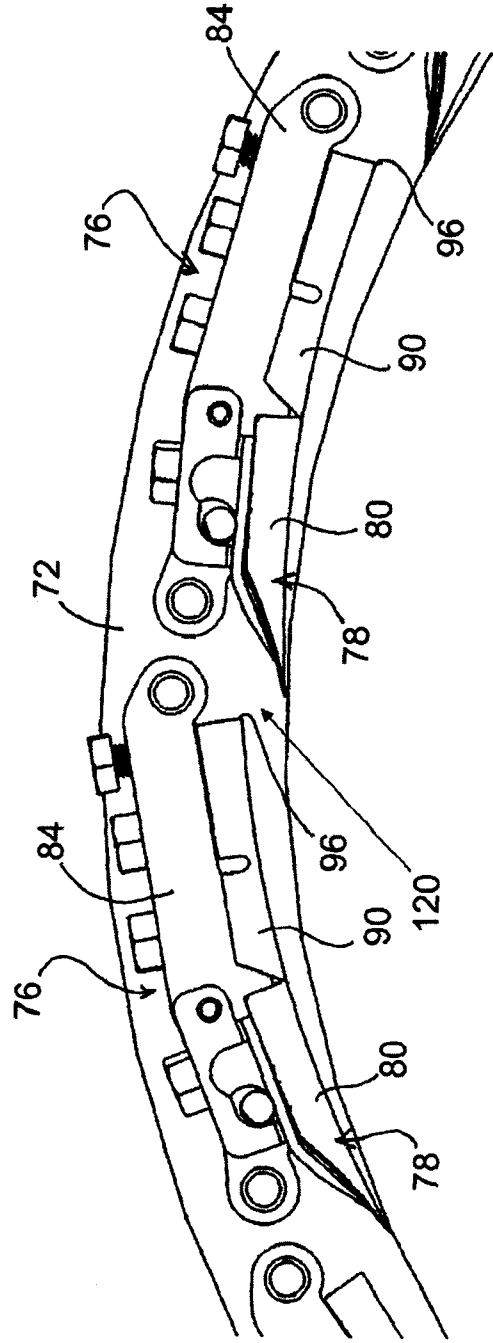

FIG. 25

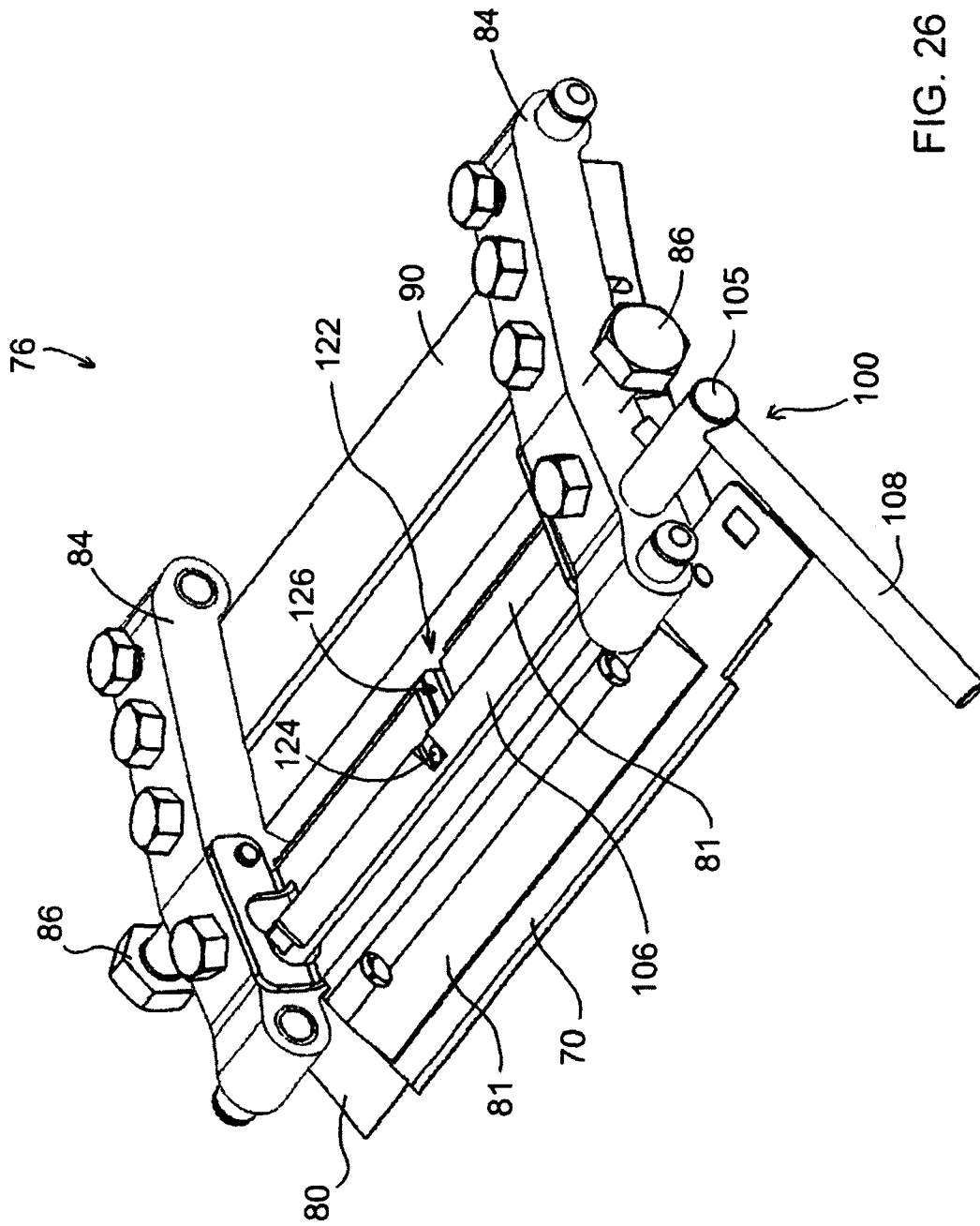

FIG. 26

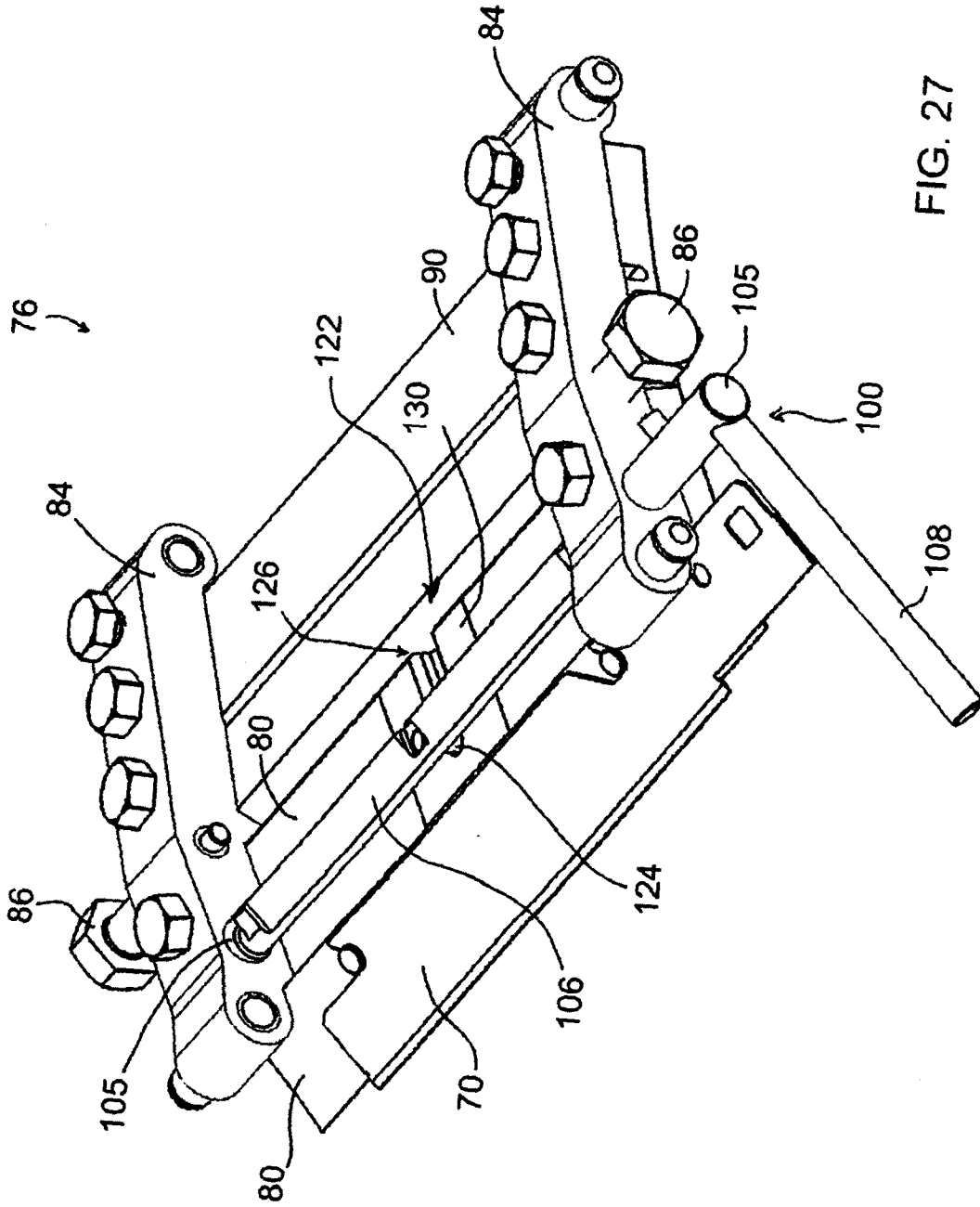

FIG. 27

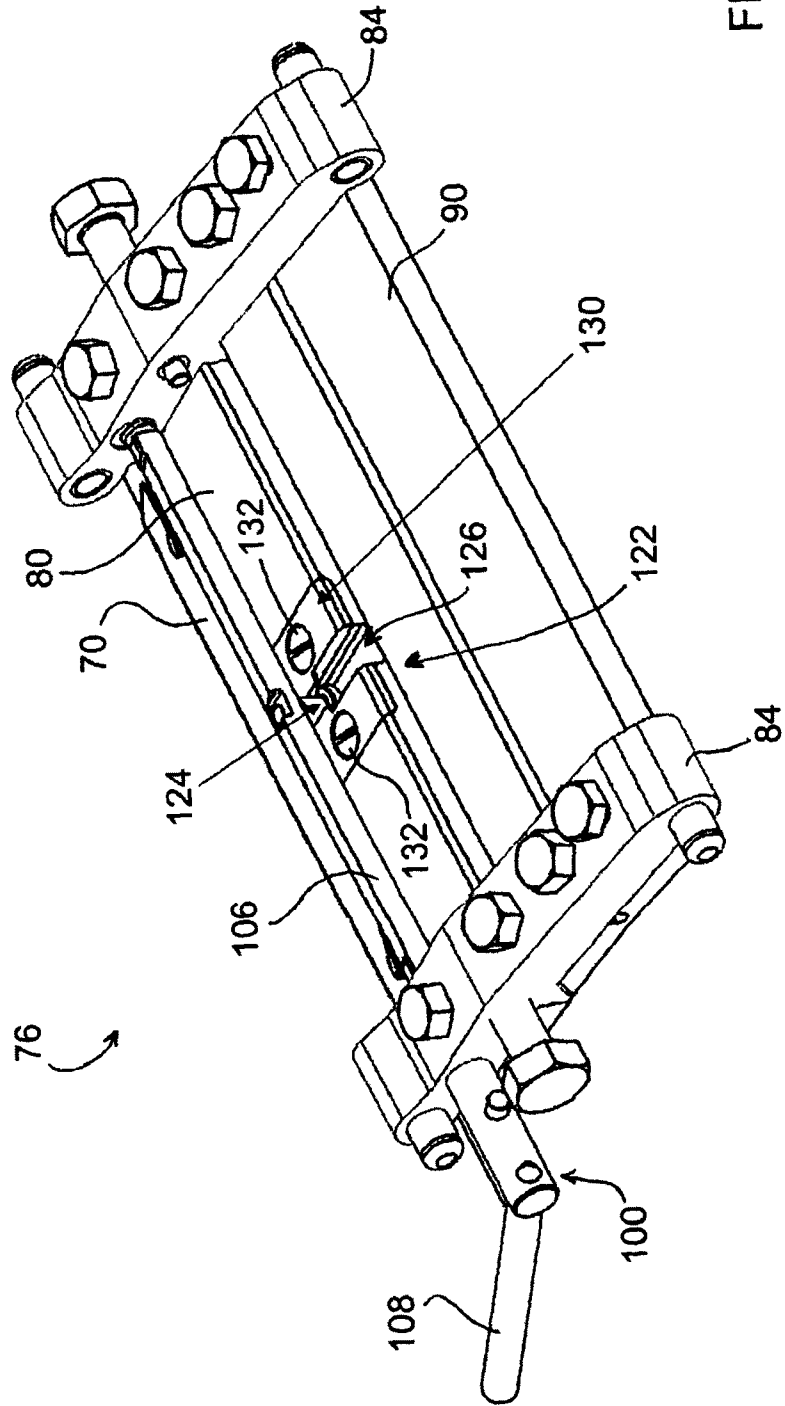

FIG. 28

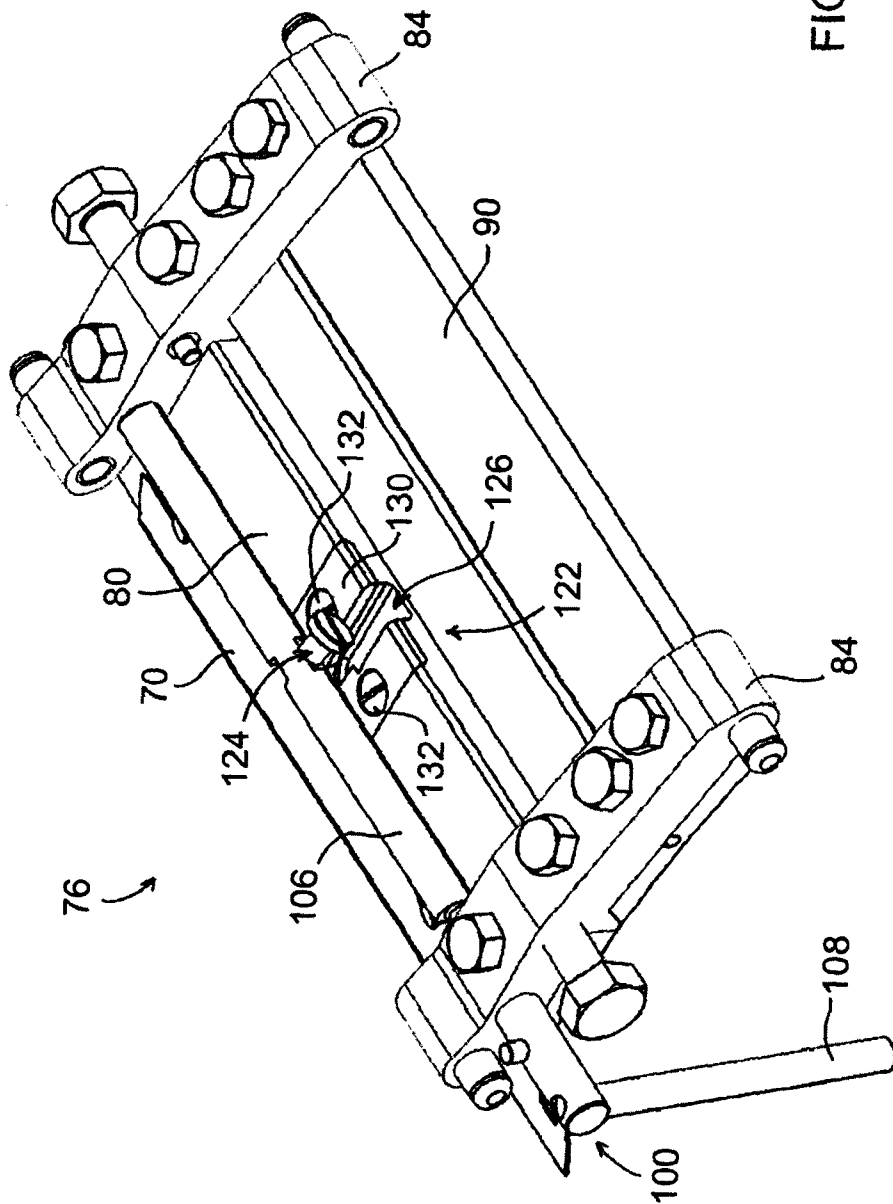

FIG. 29

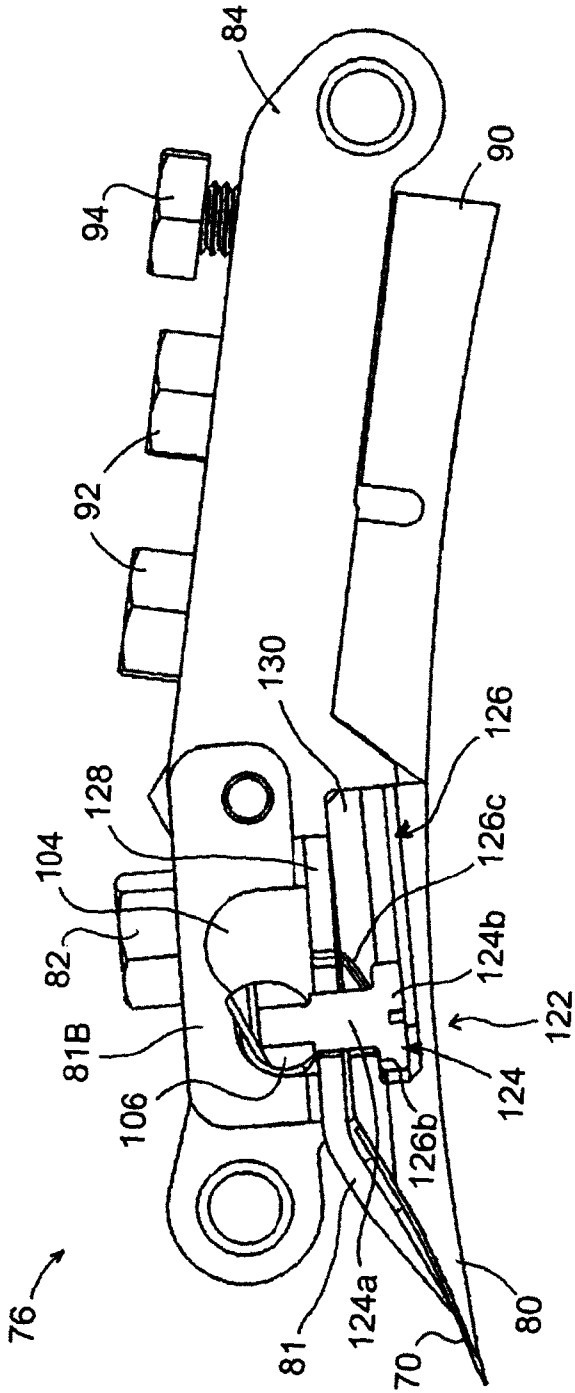

FIG. 30

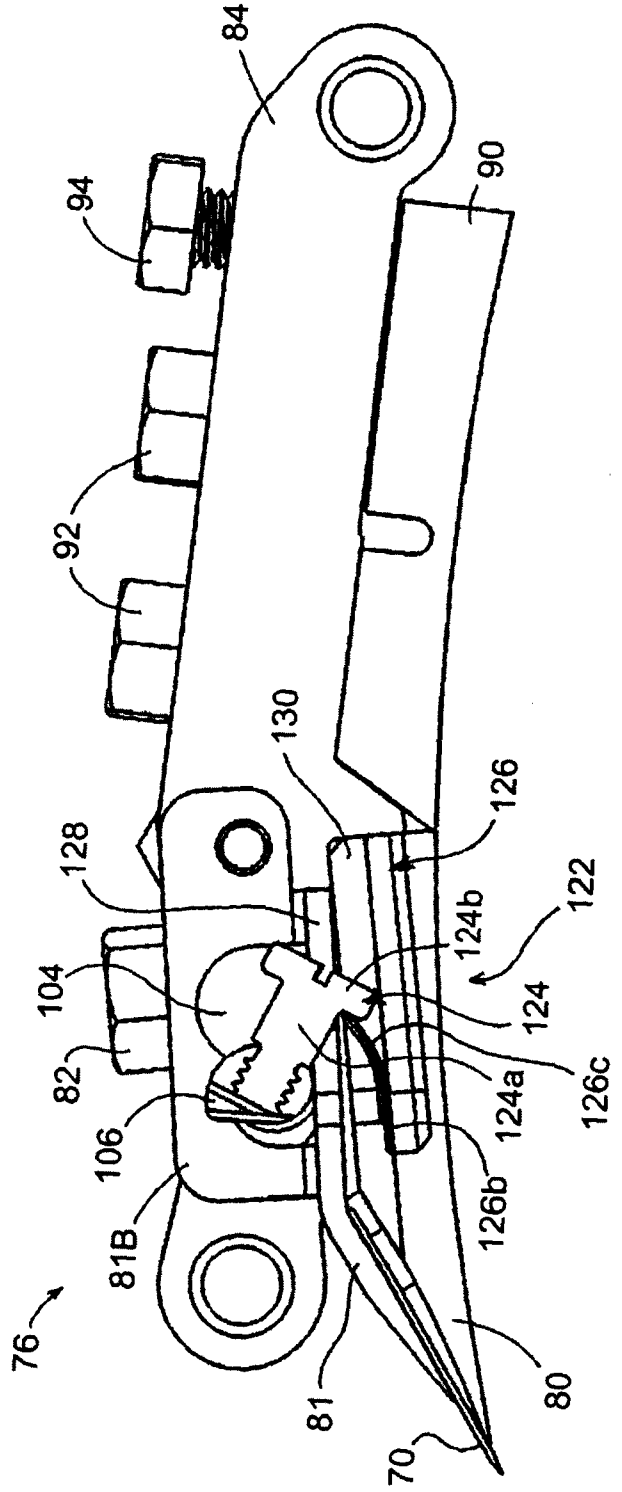

FIG. 31

