



(11) (21) (C) **2,155,107**  
(86) 1994/02/01  
(87) 1994/08/18  
(45) 2000/09/19

(72) Jacobs, Norman A., US  
(72) DeNuzzio, John D., US  
(73) BECTON, DICKINSON AND COMPANY, US

(51) Int.Cl.<sup>6</sup> A61N 1/30

(30) 1993/02/02 (08/012,168) US

(54) **DISPOSITIF D'ADMINISTRATION DE MEDICAMENT ACTIF  
ET METHODE DE PREPARATION**

(54) **ACTIVE DRUG DELIVERY DEVICE, ELECTRODE, AND  
METHOD FOR MAKING SAME**

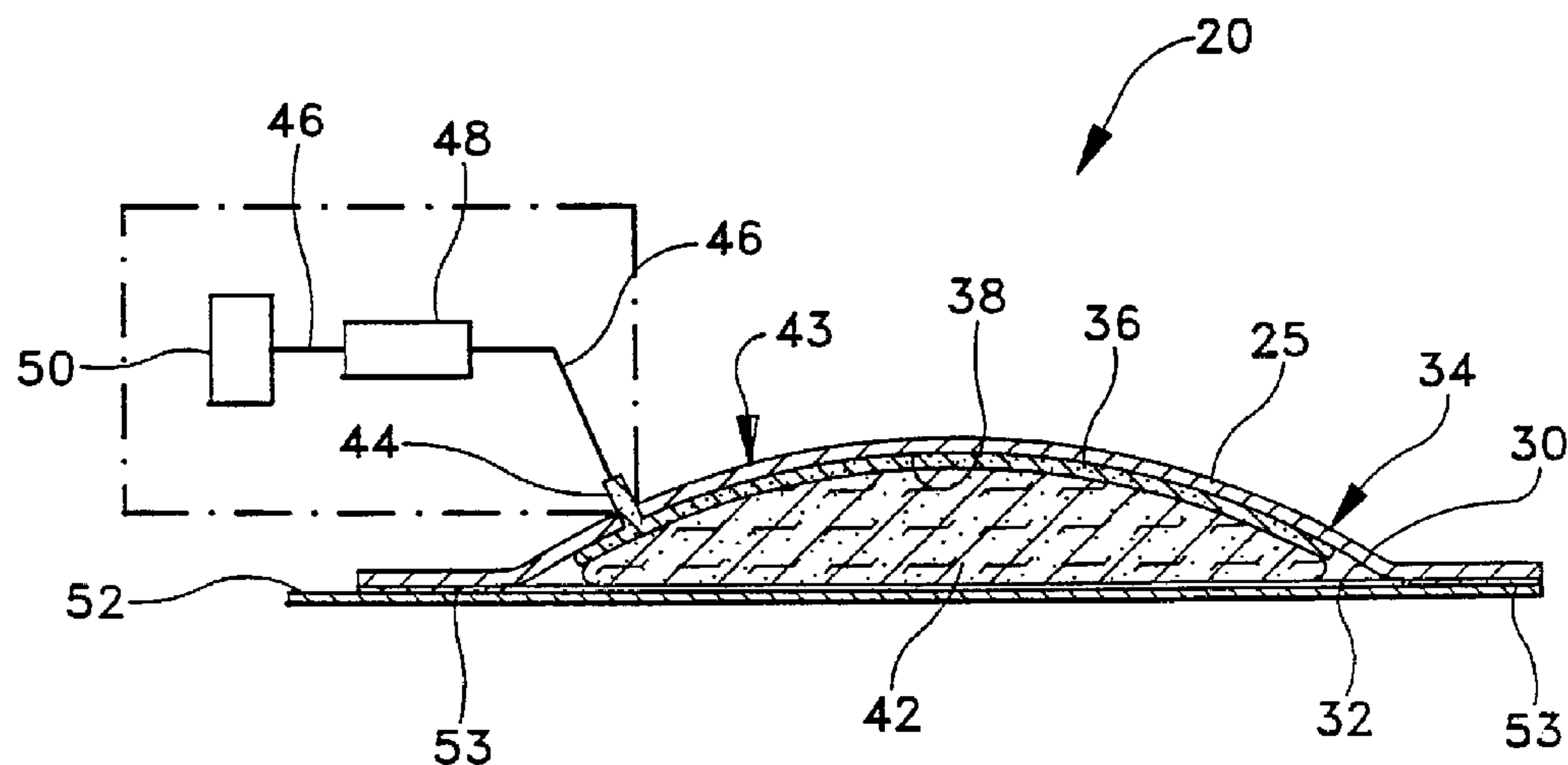

(57) Un dispositif de libération iontophorétique de médicament (20) à ensemble d'électrode active flexible (25) peut présenter au moins une électrode active flexible, au moins un réservoir (42) et un contenant ou un support (43) destiné à maintenir le réservoir et l'électrode en communication électrique. Ladite électrode active flexible est constituée d'une électrode métallique active (36) montée sur une couche dorsale flexible (30). Ladite électrode métallique active est soudée à une partie de la couche dorsale selon une configuration présélectionnée (40), une partie (41) de la surface (32) de cette dernière étant exposée. L'électrode

(57) An iontophoretic drug delivery device (20) with a flexible active electrode assembly (25) may include at least one flexible active electrode, at least one reservoir (42) and a container or holder (43) for holding the reservoir and electrode in electrical communication. The flexible active electrode device includes an active metal electrode (36) on a flexible backing (30). The active metal electrode is bonded to a portion of the backing in a pre-selected pattern (40) leaving a portion (41) of the surface (32) of the flexible backing exposed. The flexible active metal electrode contains a metal selected from the group including silver, copper and molybdenum



(11) (21) (C) **2,155,107**  
(86) 1994/02/01  
(87) 1994/08/18  
(45) 2000/09/19

métallique active contient un métal sélectionné dans le groupe comprenant l'argent, le cuivre et le molybdène et peut renfermer un sel halogène insoluble dudit métal. L'électrode peut être fabriquée à partir d'au moins une encre électroconductrice appliquée selon une configuration présélectionnée sur la couche dorsale flexible. Elle peut également être formée par application d'une couche d'argent métallique sur un circuit à électrode conducteur à première couche métallique ou un circuit à électrode à encre conductrice inerte soudé à la couche dorsale flexible.

and may contain an insoluble halogen salt of the metal. The electrode may be formed from at least one electro-conductive ink applied in a pre-selected pattern to the flexible backing or alternatively may be formed by application of a layer of metallic silver to a conductive first metal layer electrode circuit or an inert conductive ink electrode circuit which is bonded to the flexible backing.



## INTERNATIONAL APPLICATION PUBLISHED UNDER THE PATENT COOPERATION TREATY (PCT)

<p>(51) International Patent Classification<sup>5</sup> : A61N 1/30</p>	A1	<p>(11) International Publication Number: <b>WO 94/17853</b></p> <p>(43) International Publication Date: 18 August 1994 (18.08.94)</p>
<p>(21) International Application Number: PCT/US94/01152</p> <p>(22) International Filing Date: 1 February 1994 (01.02.94)</p> <p>(30) Priority Data: 08/012,168      2 February 1993 (02.02.93)      US</p> <p>(71) Applicant: BECTON DICKINSON AND COMPANY [US/US]; One Becton Drive, Franklin Lakes, NJ 07417-1880 (US).</p> <p>(72) Inventors: JACOBS, Norman, A.; 141 Worthen Road, Lexington, MA 02173 (US). DE NUZZIO, John, D.; 1909 North Hawick Court, Chapel Hill, NC 27516 (US).</p> <p>(74) Agent: HOFFMANN, Charles, R.; Hoffmann &amp; Baron, 350 Jericho Turnpike, Jericho, NY 11753-1317 (US).</p>		<p>(81) Designated States: AT, AU, BB, BG, BR, BY, CA, CH, CZ, DE, DK, ES, FI, GB, HU, JP, KP, KR, KZ, LK, LU, MG, MN, MW, NL, NO, NZ, PL, PT, RO, RU, SD, SE, SK, UA, VN, European patent (AT, BE, CH, DE, DK, ES, FR, GB, GR, IE, IT, LU, MC, NL, PT, SE), OAPI patent (BF, BJ, CF, CG, CI, CM, GA, GN, ML, MR, NE, SN, TD, TG).</p> <p><b>Published</b> <i>With international search report.</i></p>

(54) Title: ACTIVE DRUG DELIVERY DEVICE, ELECTRODE, AND METHOD FOR MAKING SAME

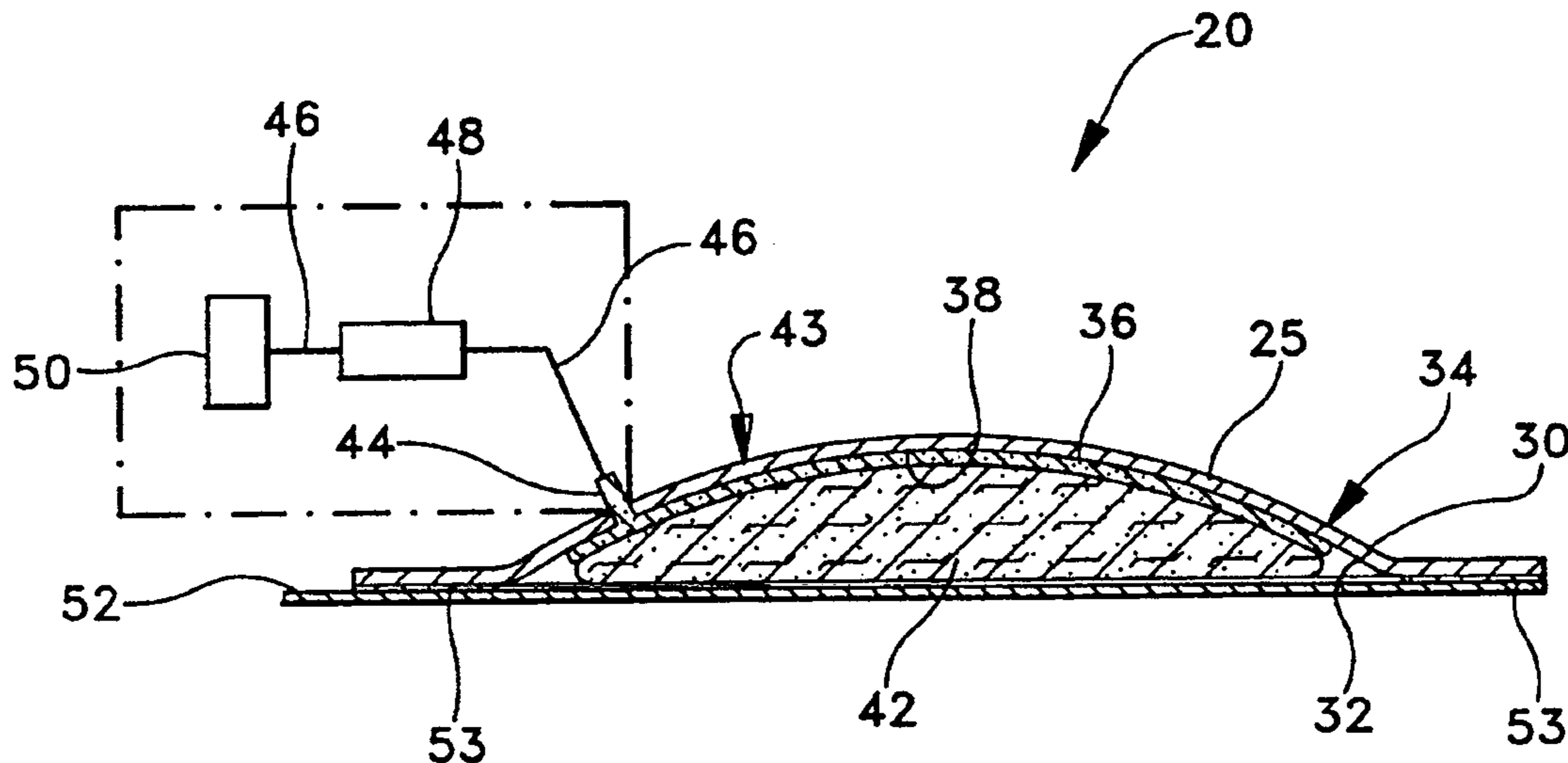

## (57) Abstract

An iontophoretic drug delivery device (20) with a flexible active electrode assembly (25) may include at least one flexible active electrode, at least one reservoir (42) and a container or holder (43) for holding the reservoir and electrode in electrical communication. The flexible active electrode device includes an active metal electrode (36) on a flexible backing (30). The active metal electrode is bonded to a portion of the backing in a pre-selected pattern (40) leaving a portion (41) of the surface (32) of the flexible backing exposed. The flexible active metal electrode contains a metal selected from the group including silver, copper and molybdenum and may contain an insoluble halogen salt of the metal. The electrode may be formed from at least one electro-conductive ink applied in a pre-selected pattern to the flexible backing or alternatively may be formed by application of a layer of metallic silver to a conductive first metal layer electrode circuit or an inert conductive ink electrode circuit which is bonded to the flexible backing.

-1-

ACTIVE DRUG DELIVERY DEVICE, ELECTRODE,  
AND METHOD FOR MAKING SAME

## FIELD OF THE INVENTION

The present invention generally relates to active devices for delivering a medicament to a patient transdermally, i.e., through the skin, and more specifically relates to an active flexible electrode which can be used in an iontophoretic device and a method for making same.

## BACKGROUND OF THE INVENTION

Transdermal administration provides a method by which a medicament can be delivered in a controlled manner to target tissues either for localized effect or for systemic absorption. The transdermal administration of a medicament offers the advantage of being a noninvasive procedure which does not require percutaneous puncture devices, and further, avoids placing stability requirements on the medicament if it is to be introduced through the gastrointestinal tract. Additionally, transdermal administration is ideally suited for sustained delivery of a medicament instead of the bolus dosage characteristic of most other modes.

There are two general types of transdermal drug delivery techniques i.e., "Passive" and "Active".

-2-

The passive technique is traceable to biblical times when healing oils and medicaments were applied to the skin of a patient. Passive transdermal drug delivery has its basis in natural physical phenomena such as osmosis, diffusion and differential solubility.

Active transdermal delivery was first reported in 1908 when it was demonstrated that ions could be driven across the skin by means of an electric current. The active techniques are termed iontophoresis, electro-osmosis and electrophoresis and are collectively referred to here simply as iontophoresis.

Presently, passive transdermal systems are most effective and used in the delivery of unionized lipophilic moieties which are active at low concentrations, e.g., nitroglycerin, nicotine, estrogen and others. Iontophoresis enables ionized solutes to be delivered transdermally and further allows control of delivery rate and duration of delivery.

Conventional iontophoretic devices, such as those described in U.S. Patent Nos. 4,820,263 (Spevak et al.), 4,927,408 (Haak et al.), and 5,084,006 (Lew et al.), are for actively delivering a medicament transdermally. Basically, these devices consist of two electrodes, i.e., a cathode and an anode. Both of these electrodes are disposed so as to be in electrical contact with some

30

-3-

portion of the skin or other area of the patient, such as a mucous membrane. One electrode called the donor electrode, is the electrode from which the ionic substance, medicament, drug precursor or drug is delivered into the body by iontophoresis. The other electrode, called the counter or return electrode, serves to close the electrical circuit through the body. In conjunction with the patient's skin contacted by the electrodes, the circuit is completed by connection of the electrodes to a source of electrical energy, e.g., a battery. In the case where the ionic substance to be delivered into the body is positively charged, i.e., a cation, then the anode will be the donor electrode and the cathode will serve to complete the circuit. If the ionic substance to be delivered is negatively charged, i.e., an anion, then the cathode will be the donor electrode and the anode will be the counter electrode. Further, it may be possible to deliver two drugs simultaneously by providing a cationic drug at the anode and an anionic drug at the cathode.

Iontophoresis should be suitable for noninvasively delivering a medicament over a sustained period. It is often desirable to maintain a certain constant level of medicaments in the patient's system instead of periodically injecting a bolus dosage. In many current iontophoretic systems, such sustained delivery is not practical because of the danger of electrical and chemical burns. U. S. Patent 4,752,285 (Petelenz et al.),

-4-

teaches these burns may stem from two sources, galvanic where the electrical current itself causes burns, and chemical where extremes in pH (which develop during the iontophoretic process) act in conjunction with electric current to cause chemical burns.

Galvanic burns can be minimized or reduced by keeping the current density per unit area of skin below threshold values at which burning begins. Low current densities can be achieved by attention to design so as to maintain uniform electrode contact with the skin. Avoidance of folds, wrinkles and partial contact of the device electrode surface with the patient's skin, all help to eliminate high current density which induces galvanic burns.

U. S. Patent No. 4,883,457 (Sibalis), teaches a multi-layer electrophoretic or electro-osmotic dispensing device with multiple reservoirs using conductors from electroconductive graphite paint. There is no suggestion that these conductors be active electrodes. The multiple layers can be fabricated by a multi-step silk screen printing or transfer process.

In addition, it has been suggested by the art that multiple electrodes and highly flexible devices may be useful in ensuring uniform contact with the patient's skin to avoid galvanic burns. Highly flexible devices are less likely to partially lift off the area of the patient's skin where they are

2155107

-5-

placed, thus avoiding spots of high current density. The use of multiple small electrodes each with its own reservoir allow each electrode area to be maintained in uniform contact with the placement area on the patient's skin.

While galvanic burns may be substantially controlled by the device design, the control of pH and the resulting burns caused by extremes in the alkalinity or acidity of the medicament solution during passage of electric current requires an understanding of the electron transfer processes which occur during active transdermal delivery. As the current passes between the electrode and the medium containing medicament, at a voltage greater than 1.23 relative to the standard hydrogen electrode (SHE) at the positive pole, the voltage necessary for electrolysis of water, there is increased production of hydrogen ions ( $H^+$ ) or at the negative pole, 0.83 volts (SHE) for the production of hydroxide ions ( $OH^-$ ). When the iontophoresis electrode is nonreactive, an increase in  $H^+$  and  $OH^-$  ion concentration is caused by the exchange of charge through the electrolysis of water.

Since the  $H^+$  and  $OH^-$  ions which result from the electrolysis of water are extremely mobile, they migrate rapidly through the electrolyte solution away from the electrode and toward the skin of the patient. Thus, an area of extreme pH is ultimately created directly adjacent to the skin. This area of extreme pH is clearly undesirable and serious burns have been observed when these ions are actively transported through the skin.

2155107

-6-

The problem of electrolysis of water with its concomitant generation of  $H^+$  and  $OH^-$  ions can be addressed by keeping the electrode potential below 1.23 volts relative to (SHE), or by the use of an electrode which is capable of reacting with the complementary ion of the medicament to form an insoluble precipitate at a voltage potential below the voltage potential for the electrolysis of water. The incorporation of a reactive electrode system into an iontophoretic device substantially eliminates the generation of  $H^+$  and  $OH^-$  ions, thus avoiding attack of the skin while maintaining the medicament at a desired pH. The use of an active electrode system with a counter ion which forms a precipitate with the electrode ion further precludes competition for transport between the counter ion and the medicament. A electrode formed from silver in conjunction with a chloride counter ion for the medicament fulfills the requirements for a reactive electrode system. While silver has been shown to perform satisfactorily in an iontophoretic system, cost constrains its use in commercial devices.

The problem of burning a patient's skin during iontophoresis thus can be substantially reduced by ensuring intimate and uniform contact between an iontophoretic delivery device and the skin and incorporation of a reactive electrode into the device.

As described above, fulfillment of the requirement for intimate and uniform contact is

2155107

-7-

facilitated by highly flexible devices and multiple electrodes. Nowhere in the art has there been a recognition that these design features could be coupled with a reactive electrode such as silver, copper or molybdenum thereby providing a significant improvement in the art of iontophoresis. Further, there has also been a need for a way to couple these design features with the ability to readily manufacture the device, while providing flexibility and minimizing the amount of silver used to improve the feasibility of widespread use of iontophoresis, thereby enhancing benefits to patients. Such methods and apparatus are disclosed and claimed herein.

15 SUMMARY OF THE INVENTION

In contrast to the prior devices discussed above, it has been found that an iontophoretic device particularly suitable for providing uniform contact with the skin, substantially eliminating burning of patient's skin while improving delivery efficiency by greatly reducing competitive ion transport can be constituted in accordance with the present invention.

25 The invention includes an iontophoretic delivery device for delivering at least one medicament to an applied area of a patient. The device includes an electrode assembly for driving a medicament for absorption into the applied area to be absorbed by a patient's body. The electrode

2155107

-8-

assembly includes a flexible backing member. The backing member has an inside surface and an outside surface. The inside surface has a first area which has at least one flexible active electrode of a preselected pattern bonded to it, while a second area of the inside surface of the flexible backing member remains exposed.

The iontophoretic delivery device further includes at least one reservoir for containing the medicament to be delivered situated in electrically conductive relation to the flexible electrode assembly. The device has a holder for holding the electrode assembly. The holder also maintains electrical communication between the electrode assembly and the reservoir.

A flexible active electrode assembly for an active drug delivery device of the present invention includes a flexible backing member with an inside surface and an outside surface. The flexible backing member has an active metal member with a preselected pattern bonded to a first area of the backing member leaving a second area of the backing member exposed. The invention further includes a method for making a flexible active electrode for an active drug delivery device. The method includes providing a flexible backing member with an inside surface and an outside surface. The inside surface has two areas, a first area and a second area. An electroconductive material is applied in a preselected pattern to the first area of the inside surface while leaving the second area of the inside

2155107

-9-

surface of the backing member exposed.

The flexible active electrode assembly may be formed from at least one electrically conductive ink applied to the backing member or alternatively from a multi-layer active electrode including a layer of silver applied to an inert ink circuit rendered conductive by the inclusion of graphite or an intermediate metal conductive circuit layer bonded to the surface of the backing member. Alternatively, the electroconductive ink may form the active electrode directly by including a first ink containing a metal selected from the group including silver, copper and molybdenum and a second electroconductive ink containing an insoluble halide salt of the metal. Alternatively, an active electrode can be formed from an ink rendered conductive by inclusion of graphite which incorporates a metal selected from the group including silver, copper and molybdenum. The active electrode may further include an insoluble halide salt of the metal selected.

Alternative embodiments may include a plurality of reservoirs, with a plurality of active electrodes. The active electrode assembly may include a system for activating the plurality of electrodes independently.

An alternative method of assembly may include the backing member as a portion of a continuous web, with a plurality of individual electrodes being formed onto the web, a cutting step may be used to

2155107

-10-

release the individual electrodes from the web for subsequent assembly into devices. A plurality of iontophoretic devices may be formed on the web by adding reservoirs and holders to a plurality of the flexible active electrode assemblies formed on portions of the continuous web, a cutting step then being used to release the devices from the web.

#### BRIEF DESCRIPTION OF THE DRAWINGS

The various features, objects, benefits, and advantages of the present invention will become more apparent upon reading the following detailed description of the preferred embodiments along with the appended claims in conjunction with the drawings, wherein like reference numerals identify corresponding components, and:

Fig. 1 is a cross-sectional view of a preferred embodiment of an iontophoretic device of the present invention having a flexible active electrode;

Fig. 2 is a top plan view of the flexible electrode of the present invention;

Figs. 3A-3E are a sequence of perspective views of stages in a preferred method for manufacture of a flexible electrode of the present invention;

Figs. 4A and 4B are enlarged fragmentary, cross-sectional views of a flexible electrode of preferred embodiments of the present invention having a plurality of active metal members wherein the members are formed as (4A) a layered structure and (4B) as an electrically conductive ink;

2155107

-11-

Fig. 4C is a top plan view of a flexible electrode of the present invention having a plurality of electrodes and electrode circuits; and

5 Fig. 5 is a top plan view of a plurality of the flexible electrodes of the present invention formed with a flexible backing member as a continuous web.

DETAILED DESCRIPTION OF THE PREFERRED EMBODIMENTS

10 The active drug delivery device of the present invention is illustrated in Figs. 1-5 and is generally designated as 20. Referring to Figs. 1 and 2, the active drug delivery device of the present invention, preferably an iontophoretic device 20, includes a flexible active electrode assembly 25 and at least one reservoir 42 for  
15 containing a medicament.

20 The electrode assembly 25 includes a flexible backing member 30 with an inside surface 32 and an outside surface 34. The electrode assembly further includes an active metal member 36 bonded to a first area 38 of inside surface 32 in a preselected pattern 40 leaving a second area 41 of surface 32 exposed.

25 Reservoir 42 is held in electrically conductive relation to the electrode assembly by a container or holder 43 which also serves to hold the flexible electrode assembly and maintain the electrode assembly and reservoir in electrical communication. The holder may include a connector 44 and conductors

2155107

-12-

46. Device 20 may further include a driver assembly 48 and a counter electrode 50 connected by conductors 46 to complete the electrical circuit.

5 Device 20 may further include a protective release covering 52 held to the device by a layer of adhesive 53. The layer of adhesive 53 may also serve for mounting the device to an area of a patient to which the medicament is to be applied.

10 The preferred device 20 may have flexible backing member 30 serve as the backing member for the reservoir, with inside surface 32 also serving as the inside surface of reservoir 42 and outside surface 34 serving as part of holder 43 for the device.

15 Materials suitable for use as flexible backing member 30 include, but are not limited to, flexible films formed from polyethylene, polyethylene terephthalate, polyvinyl chloride and polyvinylidene fluoride. The particular material is not essential  
20 to the present invention as long as it provides flexibility, sufficient support for the active metal member and is compatible with the medicament system.

25 The method of making the electrode assembly of the present invention is generally shown in Figs. 3A through 3E. The active electrode assembly 25 may be prepared with active metal member 36 bonded to inside surface 32 of flexible backing member 30. A flexible conductive metal layer, preferably a

2155107

-13-

flexible foil, 60 forms an electrode circuit 61 which then has a layer of metallic silver 62 bonded thereto to form the active metal member 36, with conductive foil 60 thereby intermediate silver layer 62 and backing member 36. An alternative for formation of active metal member 36 would be to form electrode circuit 61 from an ink rendered conductive by the incorporation of graphite and the like, then bonding metallic silver as a layer thereto.

10 In a preferred embodiment of this method, as shown in Figs. 3A and 3B, forming the preferred active metal electrode assembly includes bonding a layer of conductive metallic foil 60, preferably a layer of copper, to inside surface 32 of flexible  
15 backing member 30. Preselected pattern 40, a photoresist or the like, as shown in Fig. 3C, is then formed on a surface 63 of foil 60. One skilled in the art will appreciate that the preselected pattern may be simple, as shown in Fig. 2, or  
20 complex, with multiple segments and the like. A portion of foil 60 is removed by, for example, etching the surface, with a portion 64 of the preferred foil not included in pattern 40 being removed, thereby forming electrode circuit 61 and exposing second area 41 of surface 32 (Fig. 3D).  
25 The etch process may be an acidic dissolution process, an electrochemical enhanced milling process, an ion milling, a laser milling process and the like for removal of portion 64 of the foil to  
30 leave electrode circuit 61 as shown in Fig. 3D. The particular process is not material to the present invention and is merely a matter of choice.

2155107

-14-

In a preferred embodiment, metallic silver layer 62 is then bonded to at least a portion of the electrode circuit 61 forming an active metal member 36, as shown in Fig. 3E. Metallic silver layer 62 may be applied by an electroplating process, vacuum sputtering or any other method which results in a uniform layer of metallic silver being formed over the metallic foil electrode circuit. The preferred embodiment of the instant invention of forming a layer of metallic silver over the metallic foil electrode circuit instead of simply using silver for the entire electrode circuit serves to minimize the amount of the more expensive silver while maximizing the surface contact area of the silver with the reservoir, thereby enhancing the transfer of silver ions to the counter ion. In addition, by applying the silver after etching the foil to form the electrode circuit, waste of the silver is also further eliminated. In addition, it should be appreciated that the amount of silver applied can vary depending upon the intended application. For example, a thicker layer of silver may be applied when the device is to be used for an extended period of time for delivery of larger quantities of medicament. Further, areas of an electrode circuit external to the reservoir may be left free of silver by masking during the silver application. The metallic silver portion may be treated to form silver chloride on its surface. A preferred method of treatment to form the silver chloride would be to treat the silver layer with aqueous hydrochloric acid while applying an electric current to the electrode.

2155107

-15-

The preferred embodiment shown in Fig. 2 may have active metal member 36 formed from an electrically conductive ink containing a metal selected from the group including silver, copper and molybdenum, all of which form insoluble halide salts, with silver being preferred. The active metal member 36 may be formed from at least one electrically conductive ink applied in preselected pattern 40 on inside surface 32 (Figs. 3A and 3D). The electroconductive ink may further include graphite and an insoluble halide salt of the selected metal. In addition, to provide a counter electrode, a second electroconductive ink containing an insoluble halogen salt of the metal may be applied in a preselected pattern. A more preferred embodiment of the ink includes metallic silver with silver chloride. The techniques for application of ink 54 may include, but are not limited to, impression, lithography, offset, gravure, jet application, silkscreen and the like. One skilled in the art of application of electroconductive inks will recognize that the electroconductive inks containing one of the metals selected from the group silver, copper and molybdenum with or without the insoluble halide salt of the selected metal may be applied so as to maximize the surface exposure of the included metal and halide, thereby ensuring maximum utilization of the metal and function of the electrode. The aforementioned ink application techniques may easily be utilized to apply preselected patterns of more than one electroconductive ink for more than one circuit to a device, analogous to multicolor printing processes.

2155107

-16-

The active electrode embodiment with a silver anode is preferred for cationic drugs having a chloride anion because silver chloride is very insoluble in aqueous systems and further, many cationic drugs are readily available and stable as the hydrochloride salts. An iontophoretic delivery of such a drug with a silver anode, i.e., an active silver electrode, will result in the oxidation of silver to silver ion at the anode surface. The silver ion will react with the available chloride ion from the reservoir and precipitate near the electrode. Consequently, the drug cation will migrate from the reservoir into the patient with greater efficiency than in the case where the drug cation had to compete with the silver cation. This reaction of silver ion with chloride ion is enhanced when silver chloride is incorporated into the electrode as described above. Further because production of  $H^+$  ion is substantially eliminated, pH changes are minimized in the reservoir.

Figs. 4A and 4B show enlarged cross sections of the preferred embodiments of active metal member 36 bonded to inside surface 32 of flexible backing member 30 in preselected pattern 40 leaving second portion 41 of inside surface 32 exposed. Fig. 4A shows the layered embodiment of active metal member 36, i.e. where the active metal, preferably silver, is layered over the electrode circuit formed from a bonded metal layer or from inert electroconductive ink as is shown in Fig. 3D. Fig. 4B shows the embodiment wherein the active metal member is

2155107

-17-

electroconductive ink which directly incorporates the active metal and/or the insoluble chloride salt of the metal.

5 As shown in Fig. 4C, any of the preferred  
embodiments of active metal member 36 may be used to  
provide a plurality of flexible electrodes 36 which  
may be formed on a single flexible backing member  
30. The plurality of electrodes 36 may be attached  
10 to either a first conductor 66 or a second conductor  
68. This arrangement of electrodes on two  
conductors allows the groups of electrodes to be  
activated independently or simultaneously. This  
concept may be expanded to a plurality of conductors  
coupled with a plurality of electrodes to allow  
15 electrodes to be activated independently or together  
by the electrode assembly driver. Alternatively,  
this ability to form independent electrodes  
separately in a preselected pattern allows for the  
formation of a first active electrode circuit  
20 containing a metal selected from the group including  
silver, copper and molybdenum and a second active  
electrode circuit containing an insoluble halide  
salt of the metal. The first electrode may include  
both the active metal and an insoluble halide salt  
25 of the active metal. In addition, by allowing for a  
plurality of electrodes on flexible backing member  
30, the instant invention allows more than one  
medicament to be contained in a plurality of  
reservoirs associated with the plurality of  
30 electrodes. The ability to replicate the electrodes  
allows a design for the device to provide optimum  
flexibility to conform to the application site on

2155107

-18-

the patient thereby minimizing galvanic type burns caused by partial contact, creases and folds.

As shown in Fig. 5, the simple and easily repeated construction of the flexible electrode of the instant invention lends itself to an assembly line process. For example, flexible backing member 30 may be a continuous web 31 and a plurality of flexible electrode assemblies 25 may be applied to the web. Each device may be formed on a portion of the web, to be further assembled into iontophoretic devices. The finished devices could then be released from the web in a final cutting step. An alternative to the completion of an iontophoretic device on the web would be completion of a plurality of flexible electrode assemblies, each on a portion of the web. The individual electrodes would be released from the web by a cutting step followed by subsequent assembly steps to form completed devices.

Thus, while preferred embodiments of the present invention have been described so as to enable one skilled in the art to practice the device, electrode and method of the present invention, it is to be understood that variations and modifications may be employed without departing from the concept and intent of the present invention as defined in the following claims. Accordingly, the preceding description is intended to be exemplary and should not be used to limit the scope of the invention. The scope of the invention should be determined only by reference to the following claims.

-19-

What is claimed is:

1           1.    A flexible electrode assembly for an  
2           active drug delivery device, comprising:

3           a flexible backing member having an inside  
4           surface and an outside surface;

5           an active metal member having a preselected  
6           pattern formed on a first area of said inside  
7           surface of said flexible backing member with a  
8           second area of said inside surface of said flexible  
9           member being exposed;

1           wherein said active metal member includes at least  
2           one electrically conductive ink, said electrically  
3           conductive ink forming a preselected application pattern  
4           on said flexible backing member; and

5           wherein a first of said electroconductive inks  
1           contains a metal selected from the group consisting of  
2           silver, copper and molybdenum, and a second of said  
3           electroconductive inks contains an insoluble halogen  
4           salt of said metal.

1           2.    The electrode assembly of claim 1 wherein  
2           said electroconductive ink contains a metal selected  
3           from the group consisting of silver, copper and  
4           molybdenum.

1           3.    The electrode assembly of claim 1 wherein  
2           at least one of said inks includes a metal selected  
3           from the group consisting of silver, copper and

-20-

4 molybdenum, and an insoluble halide salt of said  
5 metal.

1 4. The electrode assembly of claim 3 wherein  
2 at least one of said inks includes silver, graphite  
3 and silver chloride.

1 5. The electrode assembly of claim 1 wherein  
2 said active metal member further comprises:

3 a first layer of electrically conductive metal  
4 bonded to said first area of said inside surface of  
5 said flexible backing member in a preselected  
6 pattern to form an electrode; and

7 a layer of metallic silver bonded to at least a  
8 portion of said conductive first metal layer, with  
9 said conductive first metal layer being intermediate  
10 said flexible backing member and said metallic  
11 silver layer.

1 6. The electrode assembly of claim 1 wherein  
2 said active metal member further comprises:

3 an electroconductive ink applied to said first  
4 area of said inside surface of said flexible backing  
5 in a preselected pattern to form an electrode  
6 circuit; and

7 a layer of metallic silver bonded to at least a  
8 portion of said electroconductive ink, said con-  
9 ductive ink layer being intermediate said flexible  
10 backing member and said metallic silver layer.

1 7. The electrode assembly of claim 6 wherein  
2 said electroconductive ink includes graphite as a  
3 conductive component.

-21-

1           8. The electrode assembly of claim 6 wherein  
2 said metallic silver has an external surface, said  
3 surface being treated to form a layer of silver  
4 chloride thereon.

1           9. The electrode assembly of claim 1 wherein  
2 said flexible backing member includes a portion of a  
3 continuous web.

1           10. A method for forming a flexible electrode  
2 assembly for an active drug delivery device  
3 comprising the steps of:  
4           providing a flexible backing member having an  
5 inside surface and an outside surface, said inside  
6 surface having a first area and a second area;  
7           applying at least one electroconductive  
8 material to said first area of said inside surface  
9 of said flexible backing member in a preselected  
10 pattern, with said second area of said flexible  
11 backing member being exposed.

1           11. The method of claim 10 wherein the step  
2 of applying said electroconductive material includes  
3 an electroconductive metal selected from the group  
4 consisting of silver, copper and molybdenum.

1           12. The method of claim 10 wherein the step of  
2 applying said electroconductive material further  
3 comprises applying at least one electroconductive  
4 ink.

1           13. The method of claim 12 wherein the step of  
2 applying said electroconductive ink includes

-22-

3 applying a first ink containing a metal selected  
4 from the group consisting of silver, copper and  
5 molybdenum.

1 14. The method of claim 13 further including  
2 applying said first ink containing a metal selected  
3 from the group consisting of silver, copper and  
4 molybdenum to a first portion of said first area of  
5 said backing member and applying a second electro-  
6 conductive ink containing an insoluble halogen salt  
7 of said metal to a second portion of said first area  
8 of said backing member.

1 15. The method of claim 12 wherein the step of  
2 applying said electroconductive ink includes an ink  
3 containing graphite, silver and silver chloride.

1 16. The method of claim 12 wherein the step of  
2 applying an electroconductive ink includes a method  
3 selected from the group consisting of impression,  
4 lithography, offset, gravure, jet application, and  
5 silkscreening.

1 17. The method of claim 10 wherein the step of  
2 applying said electroconductive material further  
3 comprises the steps of:

4 bonding a first layer of said electrically  
5 conductive metal to said first area and said second  
6 area of said inside surface of said flexible backing  
7 member;

8 forming a preselected photoresist pattern onto  
9 said first metal layer, said pattern including a  
10 first portion of said first metal layer substantial-

-23-

11 ly corresponding to said first area of said flexible  
12 backing member;

13 etching said first metal layer to expose said  
14 second area of said flexible member to form a  
15 flexible electrode circuit from said first portion  
16 of said first metal layer; and

17 applying a layer of said metallic silver to at  
18 least a portion of said electrode circuit, with said  
19 first metal layer being intermediate said layer of  
20 said metallic silver and said flexible backing  
21 member.

1 18. A device for actively delivering at least  
2 one medicament to an applied area of a patient,  
3 through, for example, iontophoresis comprising:

4 electrode assembly means for driving a  
5 medicament into the applied area of the patient to  
6 be absorbed by the body of the patient, said  
7 electrode assembly means including a flexible  
8 backing member having an inside surface and an  
9 outside surface, said inside surface having a first  
10 area and a second area, said electrode assembly  
11 means further including at least one flexible active  
12 electrode having a preselected pattern bonded to  
13 said first area of said inside surface of said  
14 flexible backing member with second area of said  
15 inside surface of said flexible backing member being  
16 exposed;

17 at least one reservoir for containing a  
18 medicament situated in electrically conductive  
19 relation to said flexible electrode assembly means;  
20 and

21 holding means for holding said electrode

-24-

22 assembly means and said reservoir and for main-  
23 taining said flexible electrode assembly means in  
24 electrical communication with said reservoir.

1 19. The device of claim 18 wherein at least  
2 one of said active electrodes contains a metal  
3 selected from the group consisting of silver, copper  
4 and molybdenum.

1 20. The device of claim 18 wherein said active  
2 electrode assembly comprises a preselected pattern  
3 of at least one electroconductive ink applied to  
4 said first area of said inside surface of said  
5 flexible backing member.

1 21. The device of claim 20 wherein a first of  
2 said electroconductive inks contains a metal  
3 selected from the group consisting of silver, copper  
4 and molybdenum.

1 22. The device of claim 20 wherein a first of  
2 said electroconductive inks includes graphite, a  
3 metal selected from the group consisting of silver,  
4 copper and molybdenum and an insoluble halide salt  
5 of said metal.

1 23. The device of claim 20 wherein said first  
2 electroconductive ink contains a metal selected from  
3 the group consisting of silver, copper and  
4 molybdenum being applied to a first portion of said  
5 first area of said flexible backing and a second  
6 electroconductive ink containing an insoluble  
7 halogen salt of said metal being applied to a second

-25-

8 portion of said first area of said flexible backing.

1 24. The device of claim 20 wherein said  
2 electroconductive inks are applied by a technique  
3 selected from the group consisting of impression,  
4 lithography, offset, gravure, jet application and  
5 silkscreen.

1 25. The device of claim 18 wherein said active  
2 metal electrode comprises:

3 an electrically conductive first metal layer  
4 formed in a preselected pattern and bonded to said  
5 first area of said inside surface of said flexible  
6 backing material to form an electrode circuit; and

7 a layer of metallic silver bonded to at least a  
8 portion of said electrode circuit with said  
9 conductive first metal layer thereby being inter-  
10 mediate said flexible backing member and said  
11 metallic silver layer.

1 26. The device of claim 18 wherein said  
2 flexible backing member being a backing portion for  
3 said reservoir with said inside surface of said  
4 flexible backing member being adjacent an inside  
5 surface of said reservoir with said outside surface  
6 of said flexible backing member being adjacent an  
7 outside surface of said reservoir.

1 27. The device of claim 18 wherein said device  
2 includes a plurality of reservoirs and said  
3 electrode assembly means includes a plurality of  
4 said flexible active electrodes.

-26-

1           28. The device of claim 27 wherein said  
2 flexible electrode assembly means includes means for  
3 activating said plurality of electrodes independent-  
4 ly of one another.

1           29. The device of claim 18 wherein said  
2 flexible backing member includes a portion of a  
3 continuous web.

2155107

1/3

FIG-1

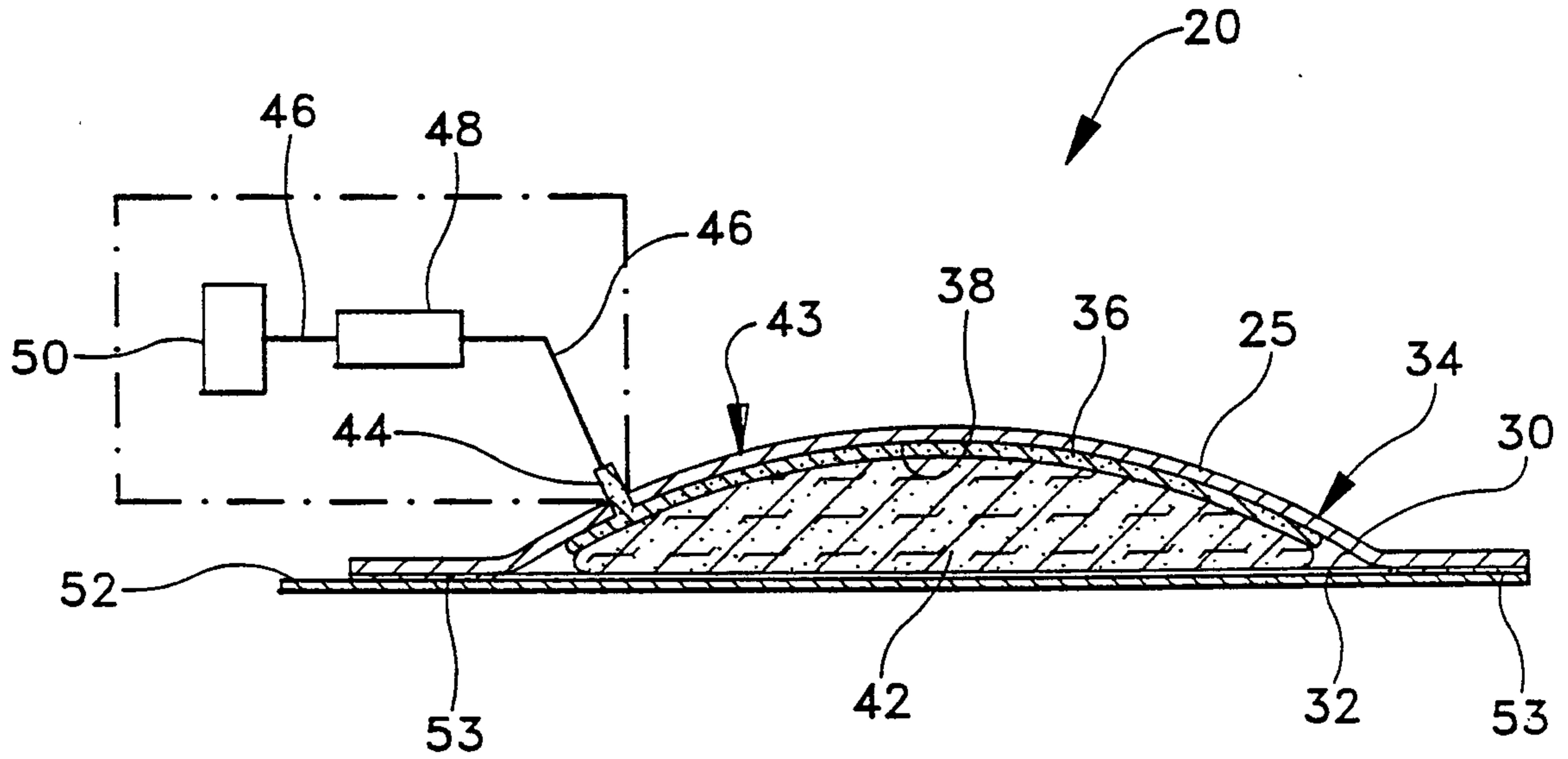
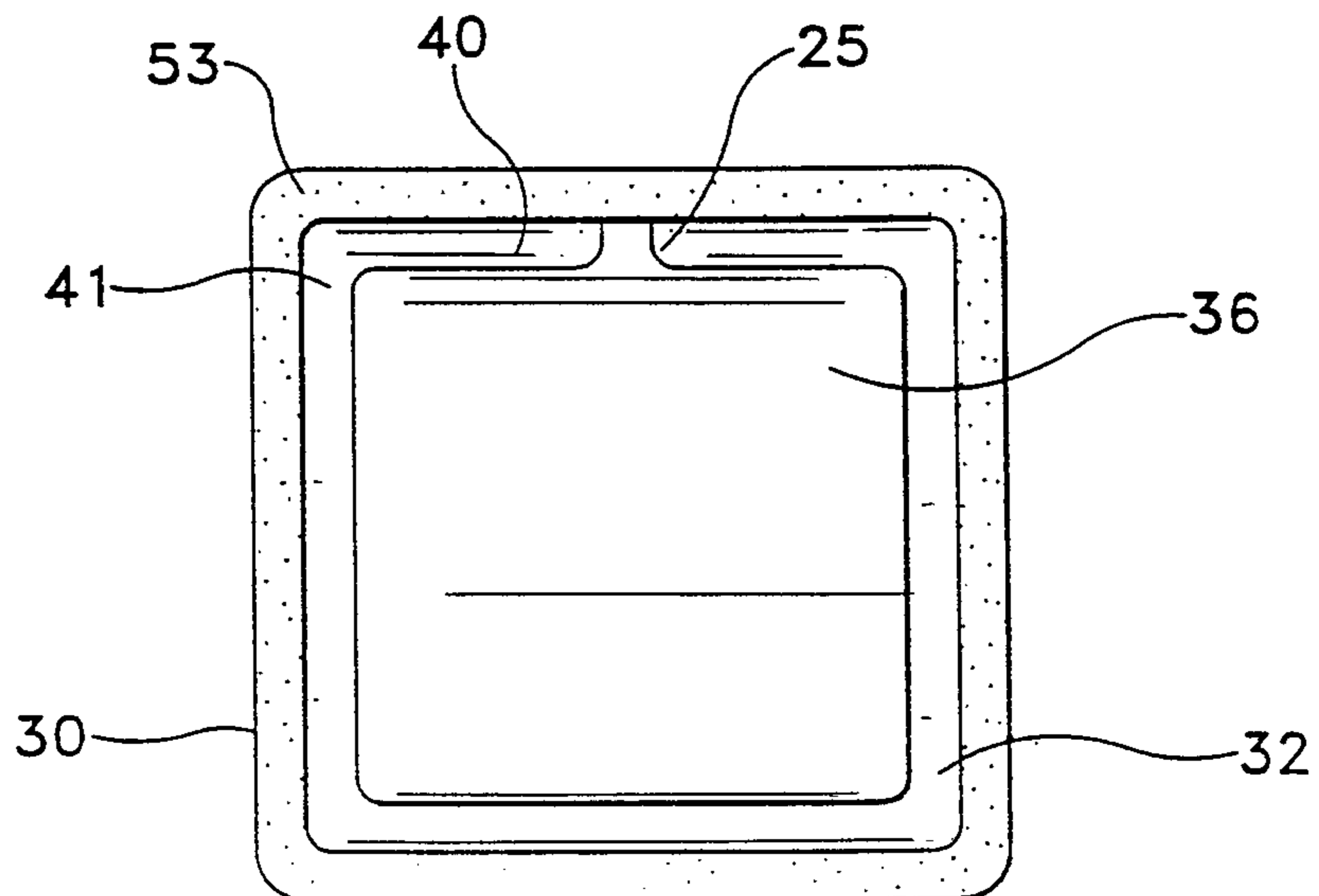

FIG-2



2155107

2/3

FIG-3A

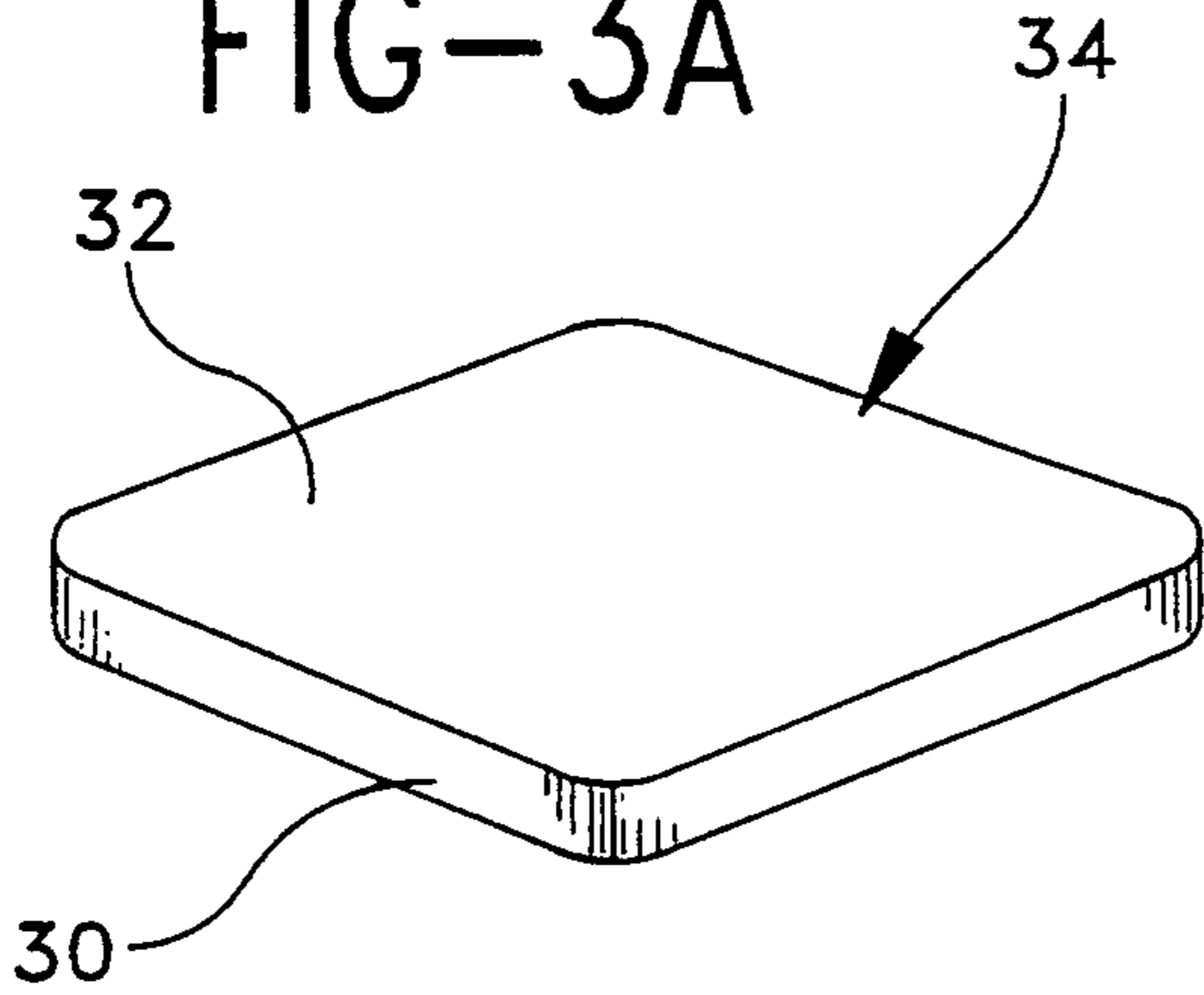

FIG-3B

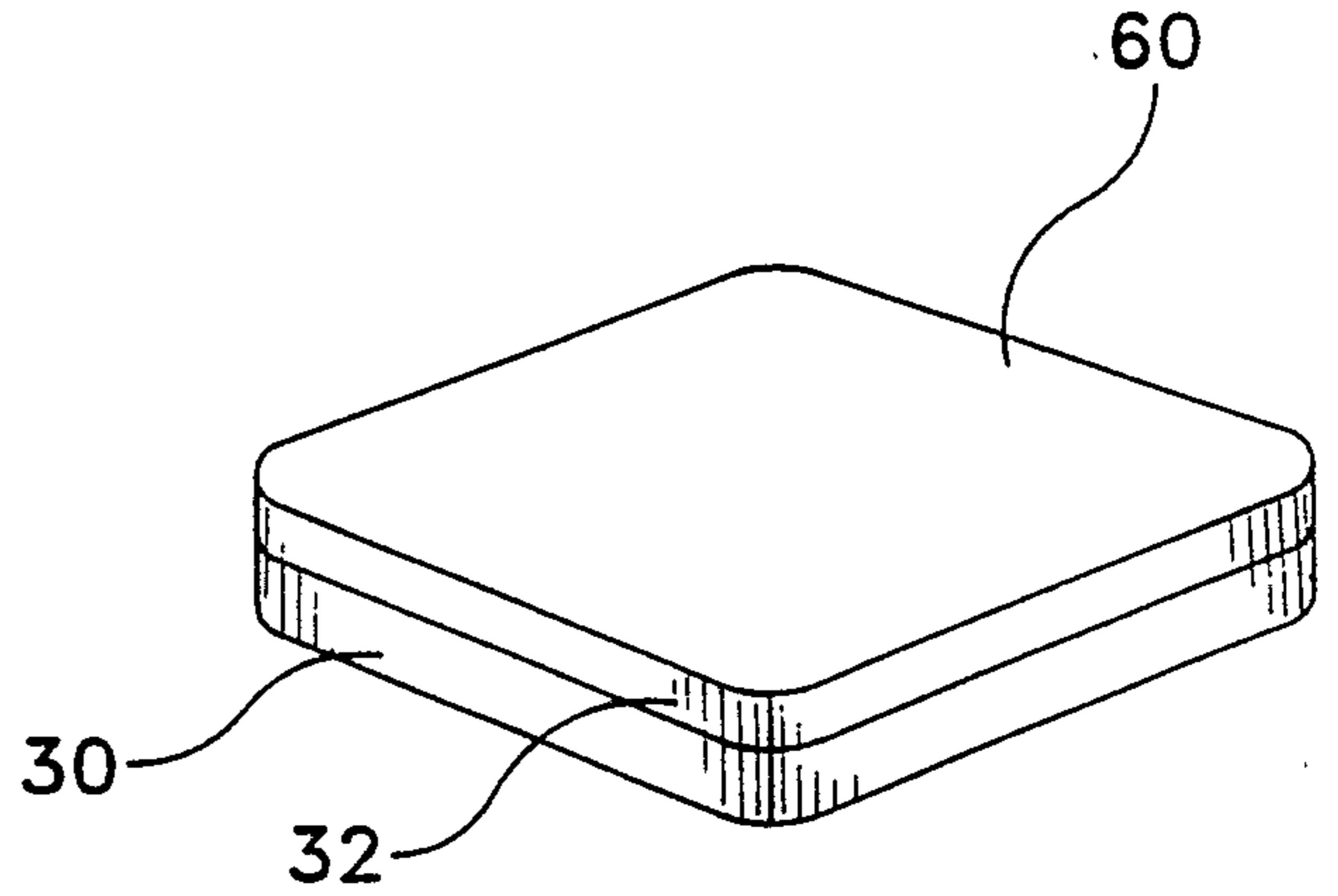

FIG-3C

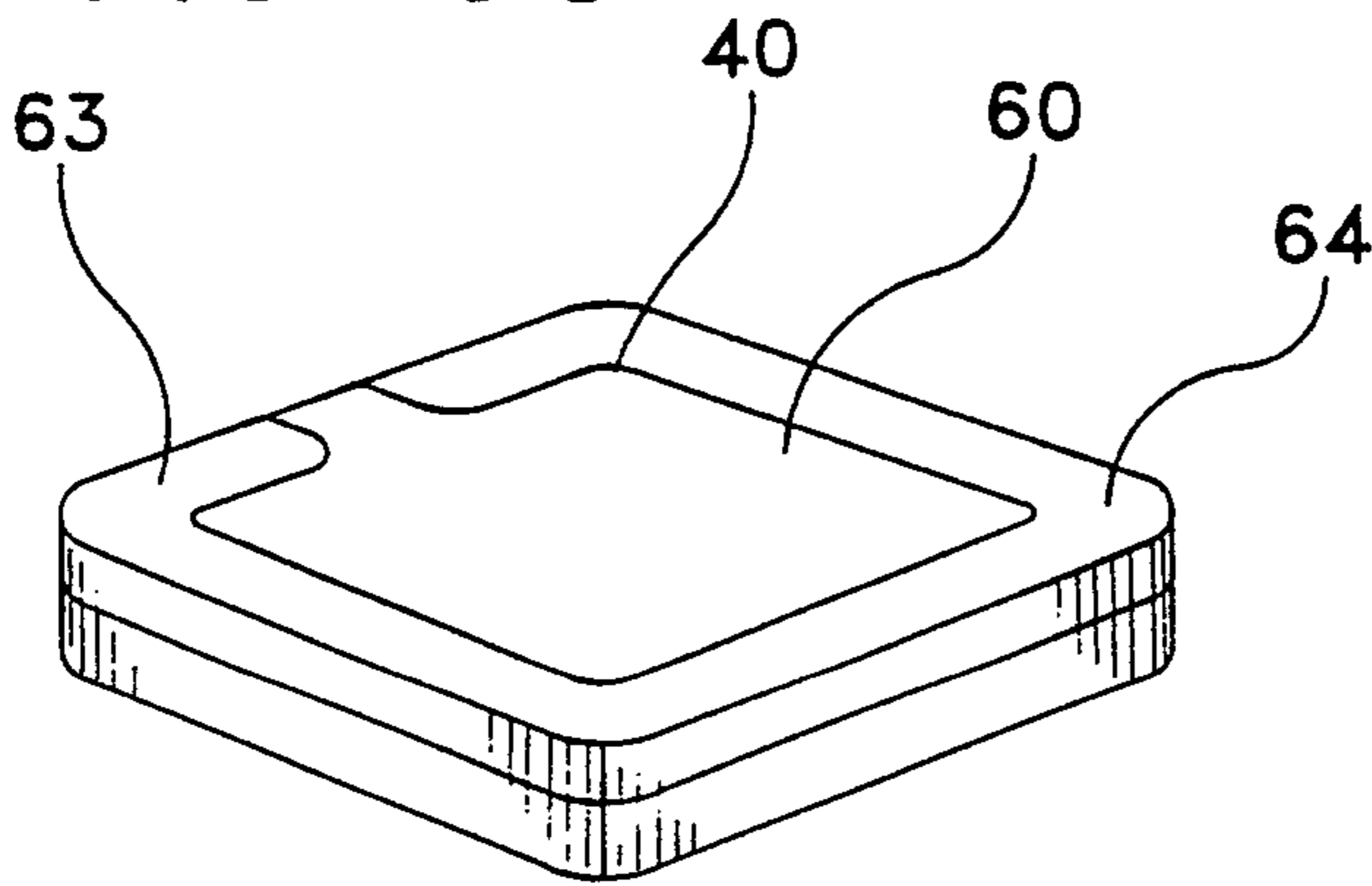

FIG-3D

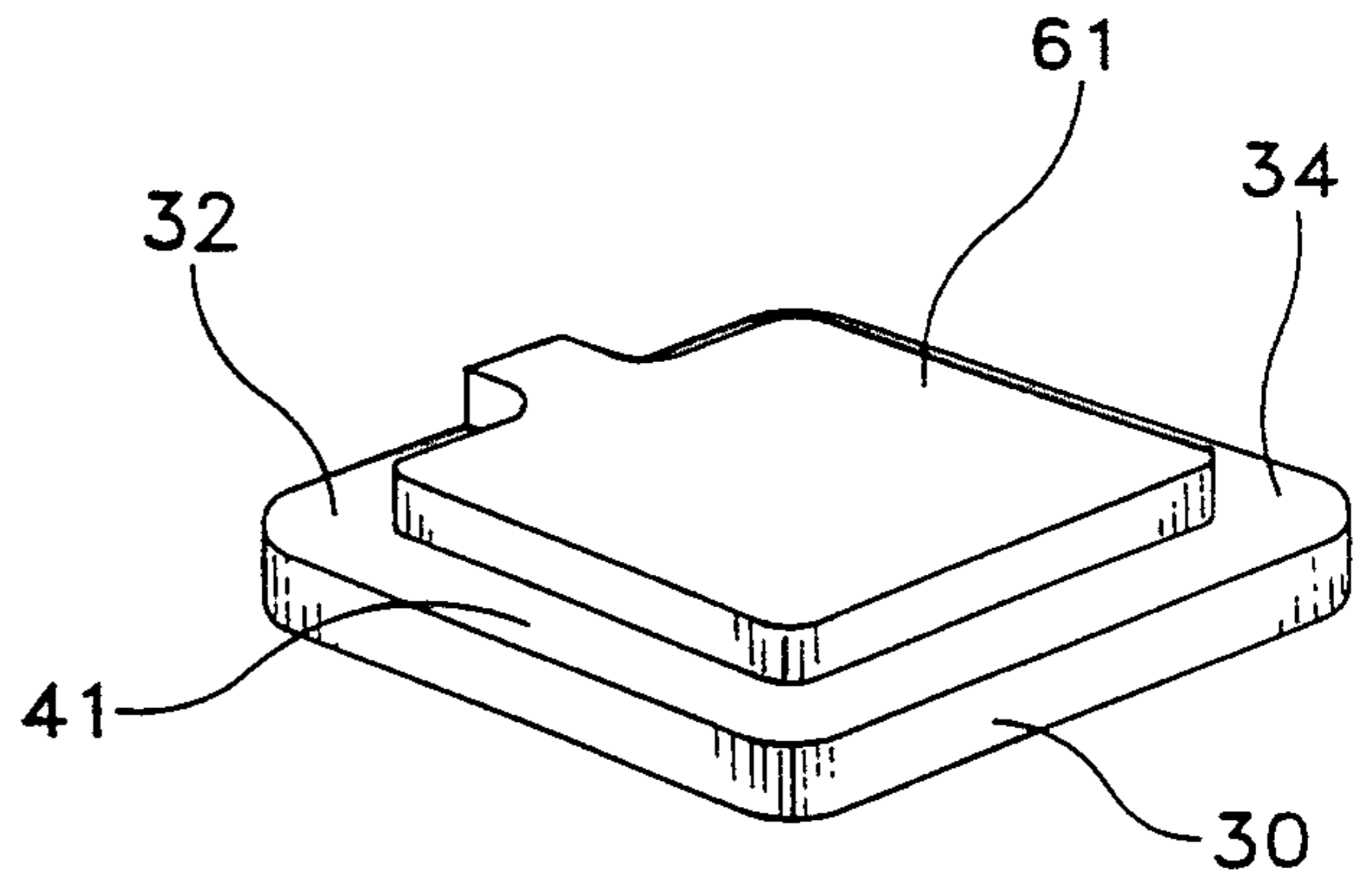
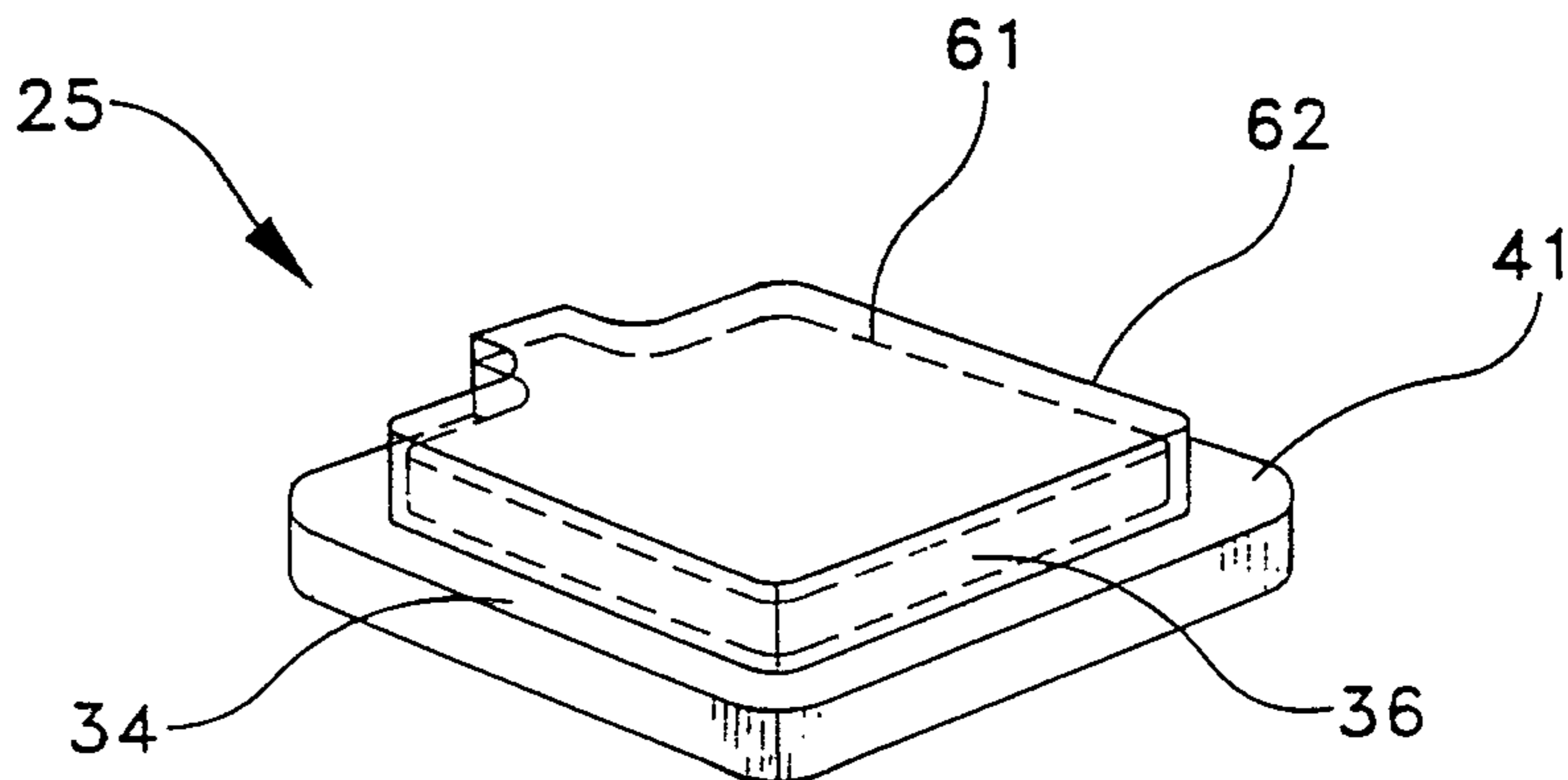

FIG-3E



2155107

3/3

FIG-4A

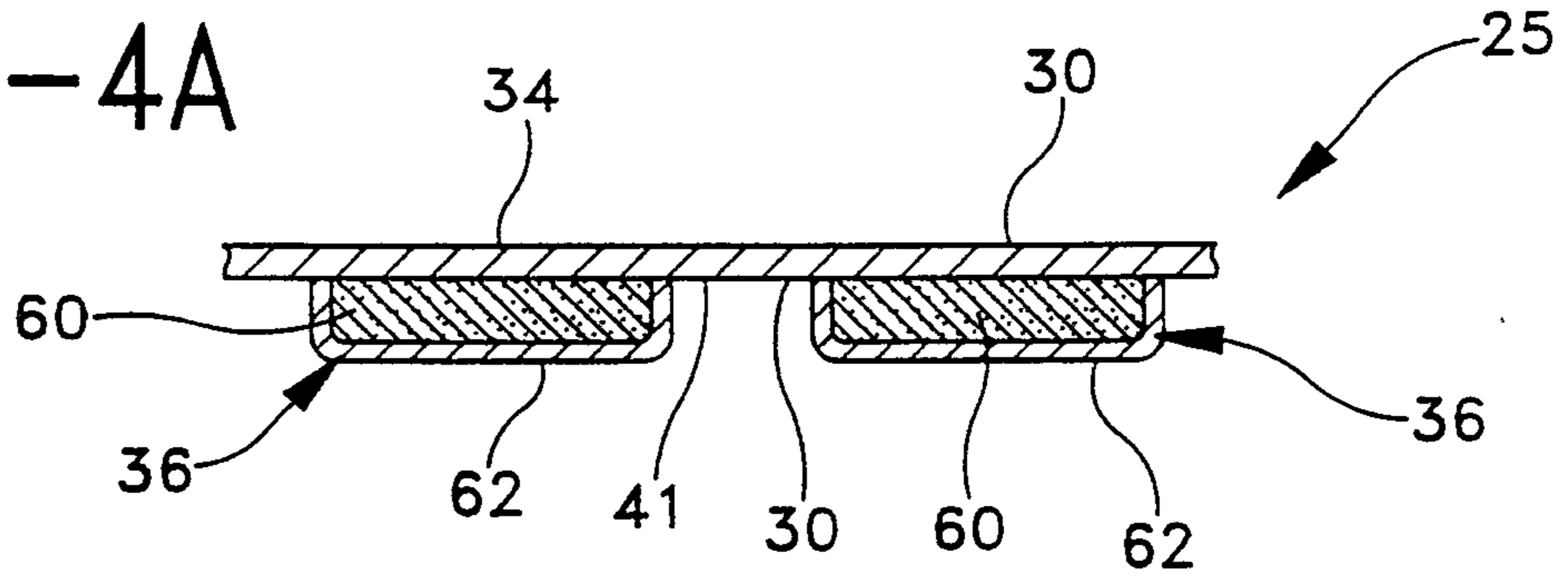

FIG-4B

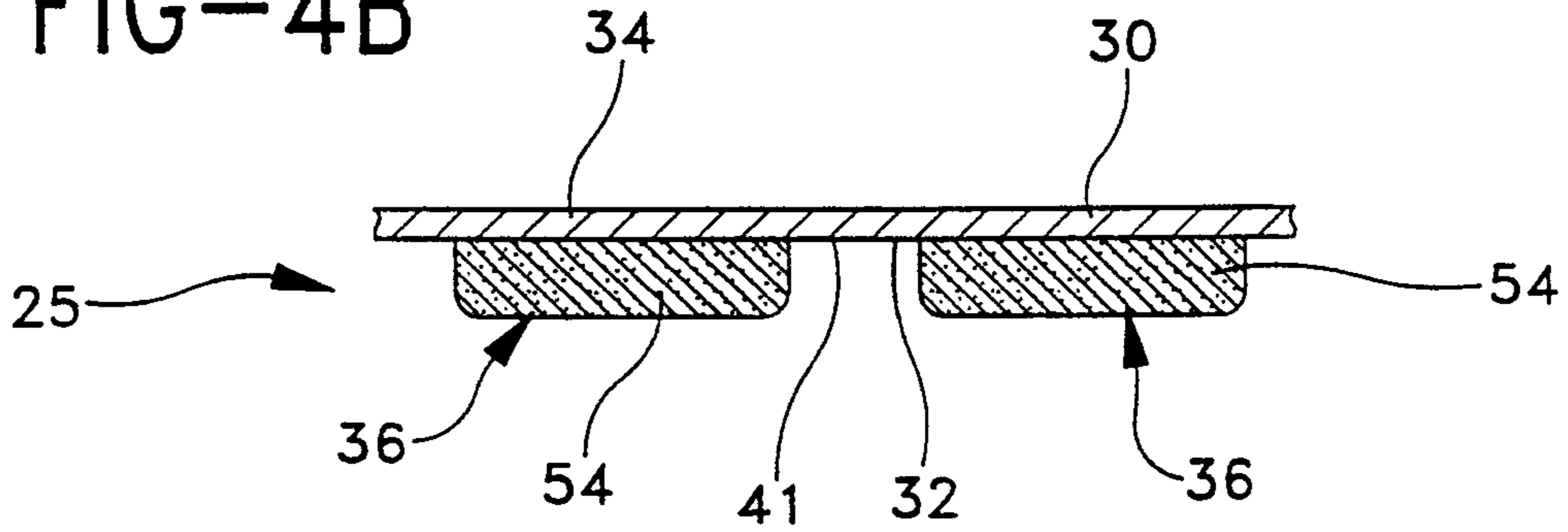

FIG-4C

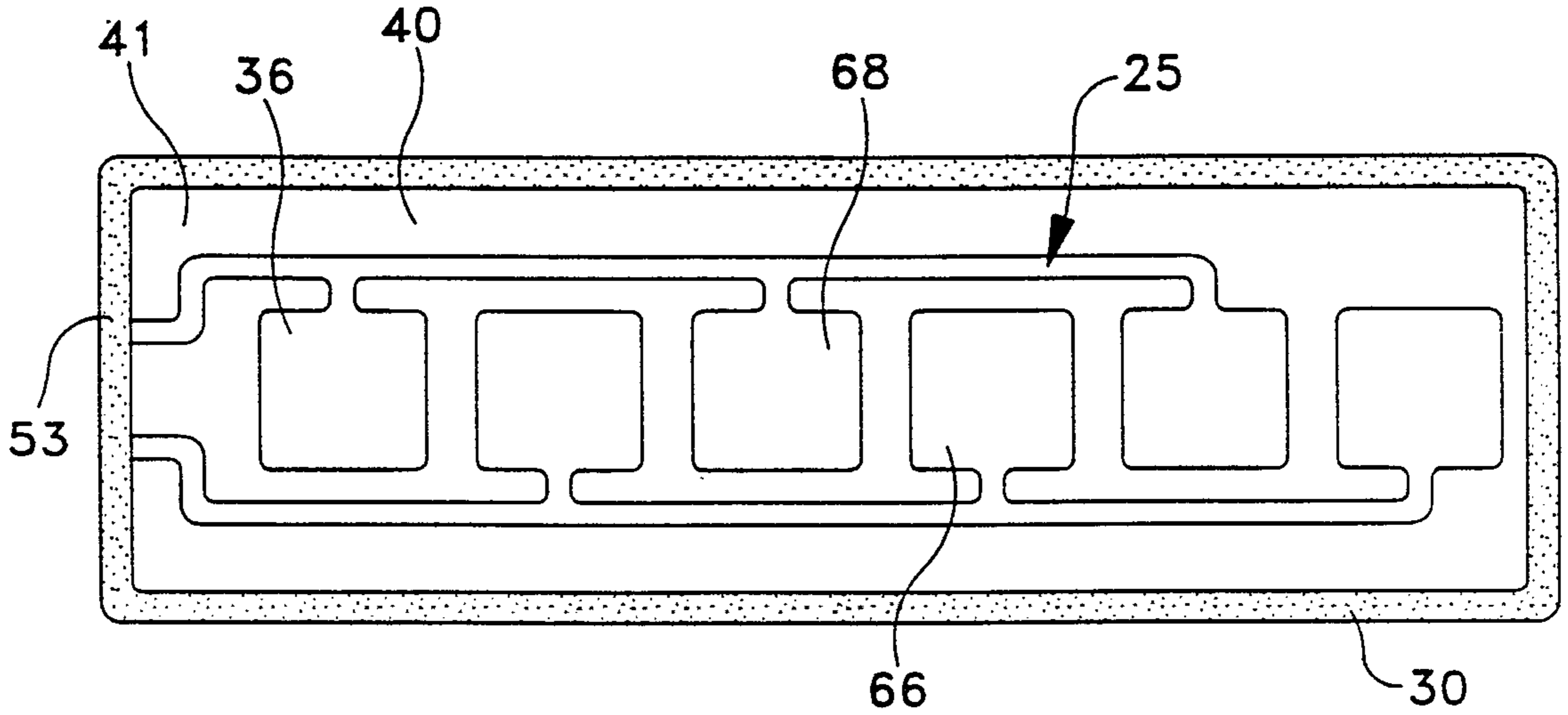
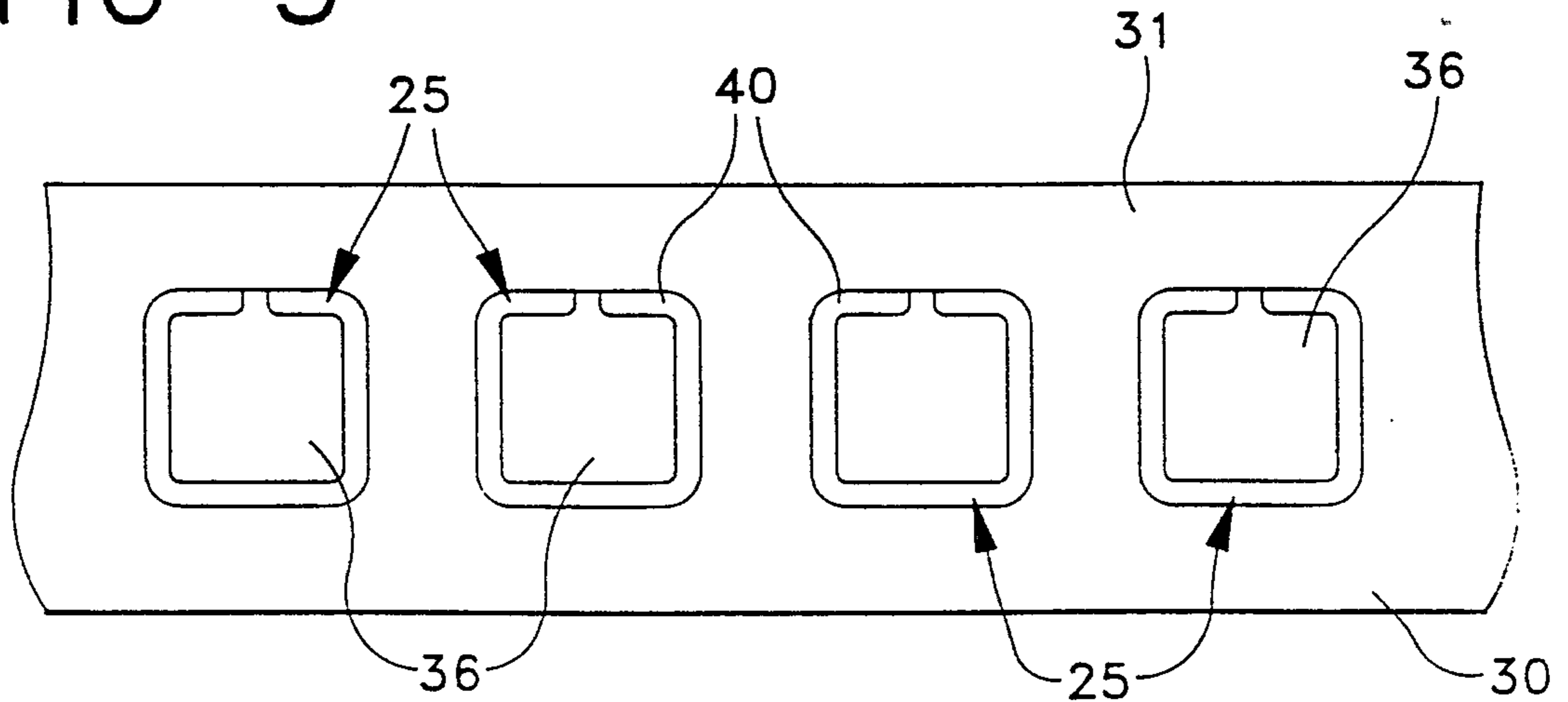

FIG-5



**SUBSTITUTE SHEET**

