

(19) **DANMARK**

(10) **DK/EP 1922044 T3**



(12) **Oversættelse af  
europæisk patentskrift**

**Patent- og  
Varemærkestyrelsen**

- 
- (51) Int.Cl.: **A 61 F 15/00 (2006.01)**                      **A 61 F 13/00 (2006.01)**                      **A 61 M 1/00 (2006.01)**  
**A 61 M 27/00 (2006.01)**
- (45) Oversættelsen bekendtgjort den: **2015-05-26**
- (80) Dato for Den Europæiske Patentmyndigheds bekendtgørelse om meddelelse af patentet: **2015-03-04**
- (86) Europæisk ansøgning nr.: **06803097.2**
- (86) Europæisk indleveringsdag: **2006-09-06**
- (87) Den europæiske ansøgnings publiceringsdag: **2008-05-21**
- (86) International ansøgning nr.: **US2006034825**
- (87) Internationalt publikationsnr.: **WO2007030599**
- (30) Prioritet: **2005-09-07 US 714912 P**
- (84) Designerede stater: **AT BE BG CH CY CZ DE DK EE ES FI FR GB GR HU IE IS IT LI LT LU LV MC NL PL PT RO SE SI SK TR**
- (73) Patenthaver: **Smith & Nephew, Inc., 1450 Brooks Road, Memphis, TN 38116, USA**
- (72) Opfinder: **PATEL, Harish, A., 24 Brett's Farm Road, Norfolk, MA 02056, USA**  
**ACHESON, Dianne, 31 Juniper Drive, Norwood, MA 02062, USA**
- (74) Fuldmægtig i Danmark: **MURGITROYD & COMPANY, Scotland House, 165-169 Scotland Street, Glasgow G5 8PL, Storbritannien**
- (54) Benævnelse: **LUKKET SÅRFORBINDINGSAPPARAT**
- (56) Fremdragne publikationer:  
**GB-A- 2 307 180**  
**US-A1- 6 142 982**  
**US-A1- 2003 040 687**  
**US-A1- 2004 054 338**  
**US-A1- 2005 090 787**  
**US-B1- 6 458 109**



# DESCRIPTION

## BACKGROUND

### 1. Technical Field

[0001] The present disclosure relates to an apparatus for treating an open wound, and, more specifically, relates to a self contained wound dressing with an external portable pump system which draws wound fluids into a collection canister supported by the patient.

### 2. Description of Related Art

[0002] Wound closure involves the migration of epithelial and subcutaneous tissue adjacent the wound towards the center of the wound until the wound closes. Unfortunately, closure is difficult with large wounds or wounds that have become infected. In such wounds, a zone of stasis (i.e. an area in which localized swelling of tissue restricts the flow of blood to the tissues) forms near the surface of the wound. Without sufficient blood flow, the epithelial and subcutaneous tissues surrounding the wound not only receive diminished oxygen and nutrients, but, are also less able to successfully fight microbial infection and, thus, are less able to close the wound naturally. Such wounds have presented difficulties to medical personnel for many years.

[0003] Wound dressings have been used in the medical industry to protect and/or facilitate healing of open wounds. One popular technique has been to use negative pressure therapy, which is also known as suction or vacuum therapy. A variety of negative pressure devices have been developed to allow excess wound fluids, i.e., exudates to be removed while at the same time isolating the wound to protect the wound and, consequently, effect recovery time. Various wound dressings have been modified to promote the healing of open wounds.

[0004] Issues that continually need to be addressed when using a wound dressing include ease of use, efficiency of healing a wound, portability and negative pressure control capabilities. Thus, there remains a need to constantly improve negative pressure wound dressings for open wounds.

[0005] US2003/0040687 is directed to a vacuum assisted tissue treatment system having a porous pad positioned within the wound cavity, and an air tight dressing secured over the pad.

[0006] US2005/090787 is directed to a control unit for a vacuum wound bandage which includes a fluid source for irrigating the wound and a canister for collecting waste material from the wound.

[0007] US2004/054338 is directed to a wound drainage system having a porous pouch positioned within the wound cavity, a sealing material secured over the pouch and to the patients skin and a vacuum pump for pumping waste material from the wound.

[0008] GB2307180 is directed to a portable pump for use with a porous dressing for draining a wound.

## SUMMARY

[0009] In accordance with a preferred embodiment, there is provided a wound dressing apparatus, which comprises:

a wound dressing member including a top layer dimensioned for positioning relative to a wound bed and a packing or absorbent layer, the top layer additionally including a vacuum port;

a portable vacuum pump in fluid communication with the wound dressing member for applying subatmospheric pressure to facilitate removal of fluid from the wound dressing member, the vacuum pump adapted to be carried by the body of a patient, the vacuum pump including control means to control operation of the vacuum pump;

an inlet tubing (116) connecting the portable vacuum pump (114) and the vacuum port of the wound dressing member (102);

a collection canister carried by the body of the patient and in fluid communication with the vacuum pump for collecting fluids removed from the wound dressing member and

an outlet tubing (120) connecting the portable vacuum pump (114) and the collection canister (118);

characterised in that a pressure sensor is disposed within an interior of the wound dressing member and the wound dressing apparatus includes a self-contained battery source, the pressure sensor being adapted to detect pressure in the wound dressing member and second a corresponding signal to the control means, the pressure sensor in electrical connection with the control means through an electrical wiring.

**[0010]** Preferably, the vacuum pump includes a peristaltic vacuum pump and is adapted to produce subatmospheric pressure ranging between about 20 mmHg and about 500 mmHg, more preferably, about 75mmHg to about 125 mmHg. The collection canister may include an absorbent material to contain the fluid removed from the wound dressing member. Preferably, the apparatus also include a body support bag which is adapted for mounting to the patient. The body support bag may have a pouch for retaining at least one of the collection canister and vacuum pump.

**[0011]** The control means may include a controller adapted to control or vary the output of the vacuum source. The vacuum pump preferably includes a self-contained battery.

**[0012]** The preferred wound dressing member includes a lower member positionable adjacent the wound bed, an upper absorbent member positionable adjacent the lower member, and a top member. The upper absorbent member comprises a material selected from the group consisting of foams, nonwoven composite fabrics, cellulosic fabrics, super absorbent polymers, and combinations thereof. The upper absorbent member may also include at least one of a medicament, an anti-infective agent, an antimicrobial, polyhexamethylene biguanide (hereinafter, "PHMB"), antibiotics, debridement agents, analgesics, healing factors, vitamins, growth factors and nutrients.

**[0013]** In another preferred embodiment, a wound dressing apparatus, includes a wound dressing member dimensioned for positioning relative to a wound bed, a portable vacuum pump in fluid communication with the wound dressing member for applying subatmospheric pressure to facilitate removal of fluid from the wound dressing member, and having a self contained battery for operating the vacuum pump, a collection canister in fluid communication with the vacuum pump for collecting fluids removed from the wound dressing member and a body support bag attachable to the body of the patient and having a pouch for retaining at least one of the collection canister and the vacuum pump..

## **BRIEF DESCRIPTION OF THE DRAWINGS**

**[0014]** Various embodiments of the subject wound dressing are described herein with reference to the drawings wherein:

Figure 1 is a partial cross-sectional view of a self contained wound dressing apparatus in accordance with the principles of the present disclosure illustrating the wound dressing member, pump system and collection canister;

Figure 1A is a cross-sectional view taken along the lines 1A-1A of Figure 1 illustrating the vacuum tube of the wound dressing apparatus;

Figure 2 is a schematic view of the pump system;

Figure 3 is a view illustrating a body support bag for containing the collection canister and/or pump system;

Figure 4 is a view illustrating an alternate embodiment of the body support bag of Figure 3; and

Figure 5 is a view illustrating an alternate embodiment of the self contained wound dressing apparatus.

## **DESCRIPTION OF THE PREFERRED EMBODIMENT**

**[0015]** The composite wound dressing apparatus of the present disclosure promotes healing of a wound via the use of an

external peristaltic vacuum pump. The external peristaltic pump applies a vacuum pressure to the wound to effectively draw wound fluid or exudate away from the wound bed. The external peristaltic pump is tethered to the wound dressing and is portable, preferably, carried by the patient, which permits patient mobility. Moreover, the patient does not need to be constrained for any period of time during therapy and while exudates is being removed from the wound.

**[0016]** Referring now to Figure 1, the wound dressing apparatus 100 in accordance with a preferred embodiment of the present disclosure is illustrated. Wound dressing apparatus 100 includes composite wound dressing 102 and pump system 104 tethered to the wound dressing 102. Wound dressing 102 is in the form of an article with multiple layers arranged in juxtaposed or superposed relation. The multiple layers include, but are not limited to a base layer 106, a packing/absorbent layer 108, and a non-porous adherent top layer 110.

**[0017]** The base layer 106 is in direct contact with the wound bed "w". The base layer 106 is typically porous and non-adherent. "Non-adherent" as used herein refers to a material that does not adhere to tissues in and around the wound bed. "Porous" as used herein refers to a material which contains numerous small perforations or pores which allow wound fluids of all kinds to pass through the material to the dressing layers above. The passage of wound fluid through the porous material is preferably unidirectional such that wound exudate does not flow back to the wound bed. This directional flow feature could be in the form of directional apertures imparted into the material layer, a lamination of materials of different absorption to the base layer 106 or specific material selection that encourages directional flow. Exemplary materials used as the base layer 106 include a contact layer sold under the trademark XEROFLO<sup>®</sup> by Kendall Corp, a division of TycoHealthcare.

**[0018]** In addition, agents such as hydrogels and medicaments could be bonded or coated to the base layer 106 to reduce bioburden in the wound, promote healing and reduce pain associated with dressing changes or removal. Medicaments include, for example, antimicrobial agents, growth factors, antibiotics, analgesics, and the like. Furthermore, when an analgesic is used, the analgesic could include a mechanism that would allow the release of that agent prior to dressing removal or change.

**[0019]** The layer proximal to the base layer 106 is the packing/absorbent layer 108. The packing/absorbent layer 108 is intended to absorb and capture wound fluid and exudates. Exemplary materials used as the packing/absorbent layer 108 include the antimicrobial dressing sold under the trademark KERLIX<sup>®</sup> by Kendall Corp., a division of TycoHealthcare. Those skilled in the art will recognize that the packing/absorbent layer 108 can be formed into any suitable shape. The only requirement as to shape is that the packing/absorbent layer 108 is suitable to conform to a particular shape of the wound.

**[0020]** A further use for the packing/absorbent layer 108 is to decrease the incidence of infection in the wound bed. Hence, the packing/absorbent layer 108 may be treated with medicaments. Medicaments include, for example, an anti-infective agent such as an antiseptic or other suitable antimicrobial or combination of antimicrobials, polyhexamethylene biguanide (hereinafter, "PHMB"), antibiotics, analgesics, healing factors such as vitamins, growth factors, nutrients and the like, as well as a simple flushing with isotonic saline solution.

**[0021]** With continued reference still to Figure 1, the top layer 110 encompasses the perimeter of the wound dressing 102 to surround the wound bed "w" to provide an occlusive seal around the perimeter of the wound bed "w". The top layer 110 may include an adhesive bonded to an area that surrounds the wound bed "w" or may incorporate an additional layer which has the adhesive. The adhesive must provide acceptable adhesion to the tissue "t" surrounding the wound bed "w" skin, e.g., the periwound area, and be acceptable for use on skin without contact deterioration (for example, the adhesive should preferably be non-irritating and non-sensitizing.) The adhesive may be semi-permeable to permit the contacted skin to breathe and transmit moisture. Alternatively, the adhesive may be impermeable. Additionally, the adhesive could be activated or de-activated by an external stimulus such as heat or a given fluid solution or chemical reaction. Adhesives include, for example, the ULTEC Hydrocolloid Dressing, by Kendall Corp., a division of TycoHealthcare.

**[0022]** The top layer 110 is preferably in the form of a sheet mounted proximal to the packing/absorbent layer 108. In a preferred embodiment, the peripheral portions 110P of the top layer 110 includes an adhesive and is secured to the tissue "t" about the wound bed "w". The peripheral portions 110P may be secured to the periphery of base layer 102 if desired. It is anticipated that removable liners may also be used to protect the adhesive surface of the top layer 110 prior to use.

**[0023]** The top layer 110 may incorporate a flexible material, e.g., resilient or elastomeric, that seals the top of the wound dressing 102. In one embodiment, the top layer 110 includes the transparent dressing manufactured under the trademark Polyskin II<sup>®</sup> by Kendall Corp, a division of TycoHealthcare. POLYSKIN<sup>®</sup> II is a transparent, semi-permeable material which permits moisture and oxygen exchange with the wound site, and provides a barrier to microbes and fluid containment. In the alternative, the top layer 110 may be impermeable. The transparency of the top layer 110 provides a visual indication of the status of the

wound dressing and more particularly, the status of the saturation level of the layers of the wound dressing. The top layer 110 further includes a vacuum port or connector 112 in fluid communication with the interior of the wound dressing 102. The vacuum port 112 may be a separate component attached to the top layer 110 and connected thereto by conventional means or integrally formed with the top layer 110. The vacuum port 112 may have a valve built therein, e.g., a one way valve, to permit exudates to flow in one direction only, i.e., away from the wound dressing 102 toward the pump system 104. Vacuum port 112 is adapted to be releasably connected to the pump system 104 as will be discussed and may or may not include structure for releasable connection to the pump system.

**[0024]** Referring still to Figure 1, the pump system 104 will be discussed. The pump system 104 includes a vacuum source 114, inlet tubing 116 connecting the inlet side of the vacuum source 114 to the vacuum port 112 of the wound dressing 102 and a collector canister 118 connected to the outlet side of the vacuum source 114 by outlet tubing 120. In the alternative, the collection canister 118 may be disposed "in-line" between the vacuum source 114 and the wound dressing 102. Vacuum source 114 may be any type of pump that is biocompatible and maintains or draws adequate and therapeutic vacuum levels. Preferably, the vacuum level to be achieved is in a range between about 20 mmHg and about 500 mmHg, more preferably, about 75 mmHg and about 125 mmHg. The pump 114 may be removable, reusable, and/or rechargeable. Typically, the pump 114 is a pump of the diaphragmatic or peristaltic type, or the like, in which the moving part(s) draw exudate out of the wound bed into the wound dressing by creating areas or zones of decreased pressure e.g., vacuum zones with the wound dressing 102. This area of decreased pressure preferably communicates with the wound bed "w" to facilitate removal of the fluids therefrom and into the packing/absorbent layer 108. The pump 114 may be actuated by any means known by those skilled in the art. In a preferred embodiment of the present disclosure, the pump 114 is a peristaltic pump. One suitable peristaltic pump is the Kangaroo PET Enteral Feeding Pump manufactured by Kendall Corp., a division of TycoHealthcare. Another suitable peristaltic pump may be the model 101 V/R pmy MK2 manufactured by Watson Marlow LTD of England. Preferably, the peristaltic pump produces subatmospheric pressure ranging from about 20mmHg to about 500 mmHg. A suitable diaphragm pump includes model NMP 850 KNDC manufactured by KNF Neuberger of Germany.

**[0025]** The inlet and outlet tubings 116,120 may be any suitable flexible tubing fabricated from elastomeric and/or polymeric materials. The inlet tubing 116 is preferably releasably connected to the vacuum port 112 through conventional means including a friction fit, bayonet coupling, snap fit or the like. The collection canister 118 may be any flexible disposable pouch or the like. The collection canister 118 may include a super absorbent material such as superabsorbent polymers (SAP), silica gel, sodium polyacrylate, potassium polyacrylamide and related compounds to consolidate or contain wound drainage or debris. The collection canister 118 is preferably transparent to permit viewing into the interior of the canister 118 to assist the patient in determining the remaining capacity of the collection canister 118 and quality of exudates.

**[0026]** Referring to FIG. 2, the pump system 104 includes an internal self contained battery source 122, a pressure sensor or transducer 124 to monitor pressure within the wound dressing, and self-contained regulation or control means 126. The pressure sensor 124 is disposed within the interior of the wound dressing 102 and is in electrical connection with the control means 126 through an electrical wiring 128. (Figure 1) One suitable pressure sensor is the Dynamic ICP Pressure Sensor of the Pressure Division of PCB Piezotronics, Inc. The pressure sensor 124 would also provide information to assist in detecting a leak in the wound dressing 102. The electrical wiring 128 may be passed through the vacuum port 112 and through inlet tubing 116 or on the exterior surface of the inlet tubing 116. Alternatively, the electrical wiring 128 may pass through a conduit or channel in the wall of the vacuum port 112 and /or the inlet tubing 116. Figure 1A illustrates the various arrangements where the electrical wiring 128 passes through the channel of the tubing 116 or the central lumen of the tubing 116. The control means 126 is preferably incorporated within the pump housing of the pump 114. The control means 126 may incorporate a motor controller/driver 130 including processing and drive software or circuitry to control or vary the drive voltage to the motor of the pump 114 responsive to the pressure sensed by the pressure sensor 124 and/or other operational parameters including operational time constraints etc. For example, the motor controller/driver may be programmed to run only for a predetermined period of time after start-up. The output of the motor of the pump 114 may be increased or decreased, or initiated or discontinued, as controlled by the control means 126. The regulation or control means 126 may also have an alarm such as a visual, audio or tactile sensory alarm (e.g., vibratory etc.) to indicate to the patient when specific conditions have been met (e.g., the desired vacuum level, loss of vacuum or leak). An override switch 130 may also be incorporated within the pump system to permit the patient to optionally initiate or terminate operation of the pump as desired without input from the control means 126. Wireless means are also envisioned to operate the pump 114 through the control means 126.

**[0027]** With reference now to Figure 3, there is illustrated a body support bag 134 for supporting at least the canister and/or the pump 114. As discussed, the pump system 104 is adapted for mounting to the body of the patient to be a self contained portal unit. In this regard, the pump system 104 may be at least partially carried or supported by the body support bag 134. The body support bag 134 generally includes a pouch 136 and at least one strap 138, preferably two straps, for securing the pouch 136 to the body of the patient. The body support bag 134 is intended to receive and store at least the collection canister 118 and/or the

pump 114. The body support bag 134 may be worn about the waist of the patient. This is desirable in that it may reduce the length of tubing needed depending on the location of the wound. In addition, the pouch 136 may be located adjacent the abdomen of the patient which may present a significantly enhanced ability to conceal the system. The inlet and outlet tubings 116,120 may be secured to the body with tape or the like, or, optionally, may be unsecured and disposed beneath the patient's clothing. Thus, the body support bag 134 permits the patient to move without restrictions or limitations, and provides an entirely portable capability to the patient during wound drainage and healing.

**[0028]** Figure 4 illustrates an alternate embodiment of the body support bag. In accordance with this embodiment, the body support bag 140 is adapted for mounting to the shoulder of the patient and has a pouch 142. In other respects, the body support bag 140 functions in a similar manner to the body support bag of Figure 3.

**[0029]** In use, the wound dressing apparatus 100 is positioned within the wound bed "w" as shown in Figure 1 and secured about the wound "w" in the manner discussed hereinabove. The pump 114 and/or collection canister 118 are positioned within the pouch 136 of the body support bag 134 (or support bag 140). The body support bag 134, 140 is mounted to the patient either about the waist, shoulder, leg, etc...with the straps 134. The inlet and outlet tubings 114,120 may be secured to the patient's body with tape or the like. Thereafter, the pump 114 is initiated to create a zone of subatmospheric pressure (i.e., a state of vacuum) within the wound dressing 100. The pump 114 may be initiated via the manual override switch 130, or may be started via the pressure sensor 124 which detects the lack of subatmospheric pressure within the wound dressing apparatus 100 and sends a corresponding signal to the control means 126. The control means 126, in turn, activates the pump 114. As the subatmospheric pressure within the wound dressing 102 increases, the top layer 110 and packing/absorbent layer 108 may collapse. Fluids are drawn away from the wound bed "w" and into the packing/absorbent layer 106 of the wound dressing 102. These fluids and /or exudates may be removed from the packing/absorbent layer 106 under the negative pumping energy of the pump 114. The fluids are delivered through the inlet and outlet tubings 116,120 to be collected within the collection canister 118. Once the desired level of subatmospheric pressure is achieved as detected by, e.g., the pressure sensor 124, the pressure sensor 124 sends a signal to the control means 126. The control means 126 may either terminate operation of the pump 114 or alternatively vary the speed or output (e.g., decrease) of the pump 114. In this vacuum state, wound fluid and exudates are continually drawn into the packing/absorbent layer 106. After a period of time, the wound dressing 102 may lose its vacuum state as detected by the pressure sensor 124 or detected visually by the patient. When the loss of a desired vacuum level is achieved, the pressure sensor 124 sends a signal to the control means 126 to activate or increase the output of the pump 114. The pump 114 removes the fluid from the packing/absorbent layer 108 and reestablishes the vacuum state within the wound dressing 102. As indicated hereinabove, in the alternative, the pump 114 may be initiated via the manual override switch 130 when e.g., the patient sees that the collection canister 118 is full. This process may continue several times during wound healing during one application or a series of applications.

**[0030]** Once the wound is fully healed, the wound closure apparatus and pump system may be disposed. The body support bag may also be disposed or cleaned for subsequent use. The pump may be sterilized and reused as well.

**[0031]** Figure 5 illustrates another embodiment of the present disclosure. In accordance with this embodiment, wound dressing apparatus 200 includes micropump 202 which is adapted for mounting within absorbent layer 204. Micropump 202 has a length ranging from about 1 to 3 inches and a relatively small diameter, preferably, no greater than about one inch. The micropump 202 may be any type of pump that is biocompatible and maintains or draws adequate and therapeutic vacuum levels. The micropump 202 may be removable, reusable, and/or rechargeable. The micropump 202 may be a pump of the diaphragmatic, peristaltic or rotary type, or the like, in which the moving part(s) draw exudates out of the wound bed into the wound dressing by creating areas or zones of decreased pressure e.g., vacuum zones with the wound dressing apparatus 200. This area of decreased pressure preferably communicates with the wound bed "w" to facilitate removal of the fluids therefrom and into the absorbent layer 204. The micropump 202 may be actuated by any means known by those skilled in the art. In a preferred embodiment of the present disclosure, the micropump 202 is a peristaltic pump. One suitable micropump is manufactured by Piab Vacuum Products in Hingham, MA. Preferably, the peristaltic pump produces subatmospheric pressure ranging from about 20mmHg to about 500mmHg.

**[0032]** Absorbent layer 204 is preferably a foam filled dressing which is transparent. The foam may be a resilient, liquid absorbent, porous, polymer-based foam. The foam may be a dispensable liquid which at least partially solidifies to a crystal-like arrangement defining hollow tubes to allow exudates drainage. The foam is dispensed within the wound bed and is potentially collapsible to expel air from the foam channels. The foam may be an expandable hydrophilic foam which is capable of absorbing fluid from a wound and maintain the wound bed moist. The hollow tubes or voids defined by the foam also provide a means to conduct electricity, heat, cold, and ultrasound. The hollow tubes or voids also provide a bioactive scaffold for tissue growth. A thin film transparent top layer 205 is secured about the wound area to enclose the wound.

[0033] The self contained battery source and control circuitry may be mounted within housing 206 which is connected to belt 208. Belt 208 is adapted for mounting to the body of a patient, e.g., around the waist area and may include VELCRO® means for securing about the patient. Belt 208 may further support canister 210 which receives the fluid exudates from pump 202 through tube 212. Tube 214 extends from housing 206 to pump 202 and may incorporate electronic wires etc. for operating the pump. In the alternative, tube 212 may incorporate the electrical wires within, e.g., a lumen, and extend from the housing to pump 202 and canister 210.

[0034] It is further contemplated that the wound dressing apparatus may incorporate external means or applications to stimulate tissue growth and/or healing. For example, an auxiliary treatment apparatus may be incorporated into the wound dressing apparatus to impart electrical or mechanical energy for the treatment of the tissue such as, for instance, directing electrical, thermal or vibratory energy on the wound area and/or introducing various drugs into the human body through the skin. The auxiliary treatment apparatus may be incorporated into the housing of the pump 202 as shown schematically as reference numeral 216 and operated via a control means discussed hereinabove. One suitable auxiliary treatment apparatus may include an ultrasonic transducer. Other sensor types are also contemplated for incorporation into the wound dressing apparatus including oxygen, chemical, microbial and/or temperature sensors. The detection of oxygen adjacent the wound area would assist the clinician in determining the status of wound healing. The presence of an elevated temperature may be indicative of an infection. The pump system may incorporate circuitry to communicate with a computer, e.g., a hand-held PALM® device through wireless means.

[0035] While the disclosure has been illustrated and described, it is not intended to be limited to the details shown. As such, further modifications and equivalents of the invention herein disclosed can occur to persons skilled in the art using no more than routine experimentation, and all such modifications and equivalents are believed to be within the scope of the disclosure as defined by the following claims.

## REFERENCES CITED IN THE DESCRIPTION

This list of references cited by the applicant is for the reader's convenience only. It does not form part of the European patent document. Even though great care has been taken in compiling the references, errors or omissions cannot be excluded and the EPO disclaims all liability in this regard.

### Patent documents cited in the description

- [US20030040687A \[0005\]](#)
- [US2005090787A \[0006\]](#)
- [US2004054338A \[0007\]](#)
- [GB2397180A \[0008\]](#)

**Krav**

1. Et sårforbindingsapparat (100), som omfatter:  
5 en sårforbindingsenhed (102) inklusive et toplag dimensioneret til positionering relativt i forhold til et sårleje ("W") og en pakning eller et absorberende lag (108), toplaget (110) derudover inklusive en vakuumport (112);  
en bærbar vakuumpumpe (114, 202) i væskekommunikation med sårforbindingsenheden (102) til tilførsel af subatmosfærisk tryk for at fjerne væske fra sårforbindingsenheden (102), vakuumpumpen (114, 202) tilpasset til at blive båret af en  
10 patients krop, vakuumpumpen (114, 202) inklusive styreanordning (126) til at styre betjening af vakuumpumpen (114, 202);  
et indgangsrør (116), som forbinder den bærbare vakuumpumpe (114) og vakuumporten (112) på sårforbindingsenheden (102);  
en samlebeholder (118) båret af patientens krop og i væskekommunikation med  
15 vakuumpumpen (114, 202) til samling af væsker fjernet fra sårforbindingsenheden (102); og  
et udgangsrør (120), som forbinder den bærbare vakuumpumpe (114) og samlebeholderen (118);  
karakteriseret ved, at en tryksensor (124) er anbragt indvendigt i sårforbindingsenheden  
20 (102) og sårforbindingsapparatet (100) omfatter en uafhængig batterikilde (122), tryksensoren (124) tilpasses til at registrere tryk i sårforbindingsenheden (102) og sende et tilsvarende signal til styreanordningen (126), tryksensoren (124) i elektrisk forbindelse med styreanordningen (126) gennem en elektrisk kabling.
- 25 2. Sårforbinding ifølge krav 1, hvor vakuumpumpen (114) omfatter en peristaltisk pumpe tilførende et subatmosfærisk tryk fra 75 mm Hg til 125 mm Hg.
3. Sårforbindingsapparat ifølge krav 1, hvor vakuumpumpen (114, 202) omfatter en  
30 peristaltisk vakuumpumpe tilførende et subatmosfærisk tryk fra 20 mm Hg til 500 mm Hg.
4. Sårforbindingsapparat ifølge krav 1, hvor samlebeholderen (118) omfatter et absorberende materiale for at indeholde væsken fjernet fra sårforbindingsenheden.
- 35 5. Sårforbindingsapparat ifølge krav 4, hvor det absorberende materiale er et superabsorberende materiale.
6. Sårforbindingsapparat ifølge krav 5, hvor det superabsorberende materiale er et

superabsorberende polymer.

7. Sårforbindingsapparat ifølge krav 1 inklusive en kropsstøttepose (134),  
kropsstøtteposen tilpasset til montering på patienten og har en pose (136) til at holde  
5 mindst en af samlebeholderen (118) og vakuumpumpe (114).
8. Sårforbindingsapparat ifølge krav 1, hvor styreanordningen (126) omfatter en kontroller  
(130) tilpasset til at styre eller variere vakuuskildens udgangseffekt.
- 10 9. Sårforbindingsapparat ifølge krav 1, hvor vakuumpumpen (114) omfatter den  
uafhængige batterikilde (122).
10. Sårforbindingsapparat ifølge krav 1, hvor sårforbindingsenheden (102) omfatter en  
15 nedre enhed (106), som kan positioneres ved siden af sårlejet og en øvre  
absorberende enhed (108, 204), som kan positioneres ved siden af den nedre enhed  
(106).
11. Sårforbindingsapparat ifølge krav 10, hvor den øvre absorberende enhed (108)  
20 omfatter et materiale valgt blandt gruppen bestående af skum, ikke-vævede  
sammensatte stoffer, cellulosestoffer, superabsorberende polymerer og kombinationer  
heraf.
12. Sårforbindingsapparat ifølge krav 11, hvor den øvre absorberende enhed (108)  
25 omfatter mindst en af et medikament, et anti-infektiøst middel, et antimikrobiel,  
polyhexametylenbiguanid, antibiotika, smertestillende midler, helende faktorer,  
vitaminer, vækstfaktorer og næringsstoffer.
13. Sårforbindingsapparat ifølge krav 1, derudover omfattende en kropsstøttepose (134,  
30 140), som kan fastgøres til patientens krop, kropsstøtteposen (134, 140) inklusive en  
pose (136, 142) til at holde mindst en af samlebeholderen (118) og vakuumpumpen  
(114).

DRAWINGS

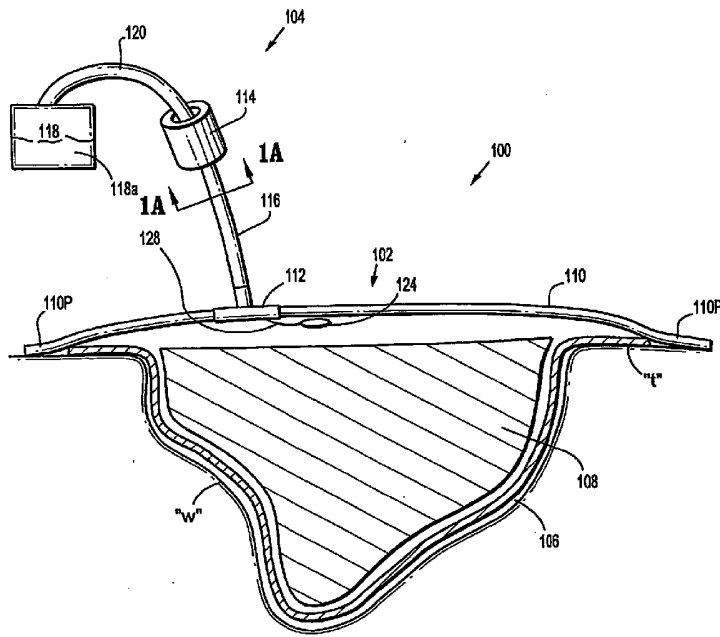

FIG. 1

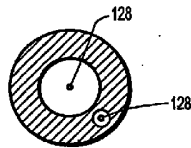

FIG. 1A

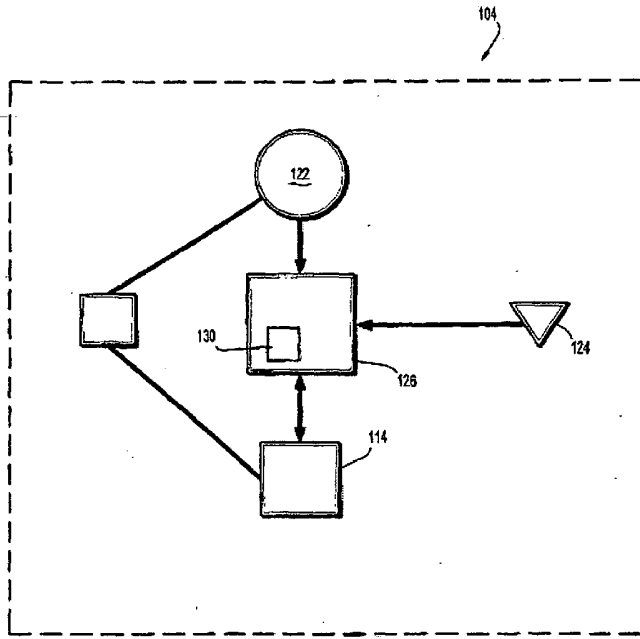
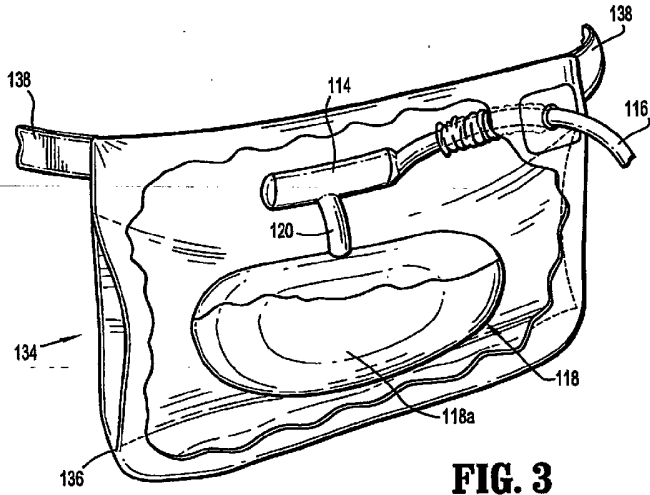
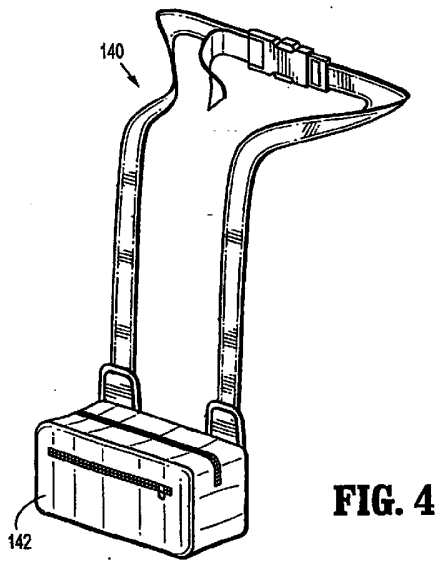

FIG. 2



**FIG. 3**



**FIG. 4**

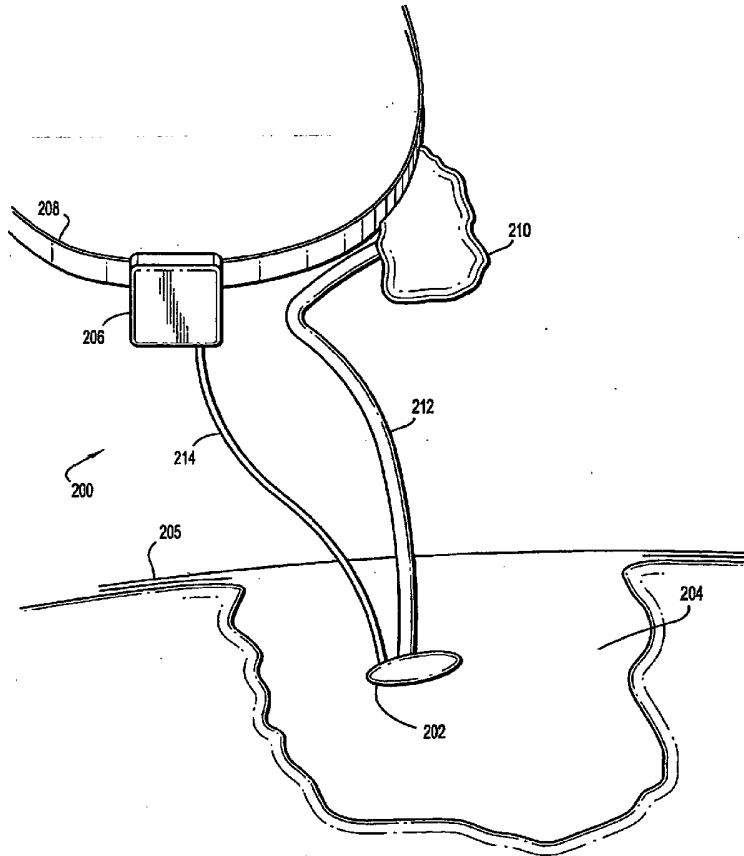

**FIG. 5**