



(19) **United States**

(12) **Patent Application Publication**

**Sane et al.**

(10) **Pub. No.: US 2007/0163250 A1**

(43) **Pub. Date: Jul. 19, 2007**

(54) **HIGHLY INSULATED EXHAUST MANIFOLD**

**Publication Classification**

(76) Inventors: **Ajit Y. Sane**, Medina, OH (US); **Bruce O. Budinger**, Chagrin Falls, OH (US); **Scott A. Churby**, Lodi, OH (US); **Dan T. Moore III**, Cleveland Heights, OH (US); **James L. Eucker**, North Ridgeville, OH (US)

(51) **Int. Cl.**  
*F01N 5/02* (2006.01)  
*F01N 7/10* (2006.01)  
*F01N 3/02* (2006.01)  
(52) **U.S. Cl.** ..... **60/323; 60/320**

Correspondence Address:  
**PEARNE & GORDON LLP**  
**1801 EAST 9TH STREET**  
**SUITE 1200**  
**CLEVELAND, OH 44114-3108 (US)**

(57) **ABSTRACT**

An exhaust manifold (10, 110) is provided having a ceramic inner layer (22, 32) defining an exhaust gas passageway (20), and a composite insulation zone (24, 26) that is highly thermally insulating. In one embodiment, the composite insulation zone (24) includes a plurality of metallic foils (31, 32) in alternating arrangement with layers having insulating qualities. In the composite insulation zone, the layers having insulating qualities can include ceramic layers (26), evacuated spaces, microsphere layers (37) including substantially evacuated microspheres, or a combination of these. A novel sealing arrangement also is provided for sealing the ceramic inner and metallic outer layers of a metal-encased-ceramic exhaust manifold at a location adjacent the inlet port (14, 15, 16) of a runner of the manifold. A sealing gasket (140) is substantially completely encased within or shielded by the metallic outer layer, so as not to contact the cylinder head (115) when assembled to an internal combustion engine.

- (21) Appl. No.: **10/590,172**
- (22) PCT Filed: **Mar. 2, 2005**
- (86) PCT No.: **PCT/US05/06510**
- § 371(c)(1),  
(2), (4) Date: **Aug. 18, 2006**

**Related U.S. Application Data**

- (60) Provisional application No. 60/549,793, filed on Mar. 3, 2004. Provisional application No. 60/559,119, filed on Apr. 2, 2004.

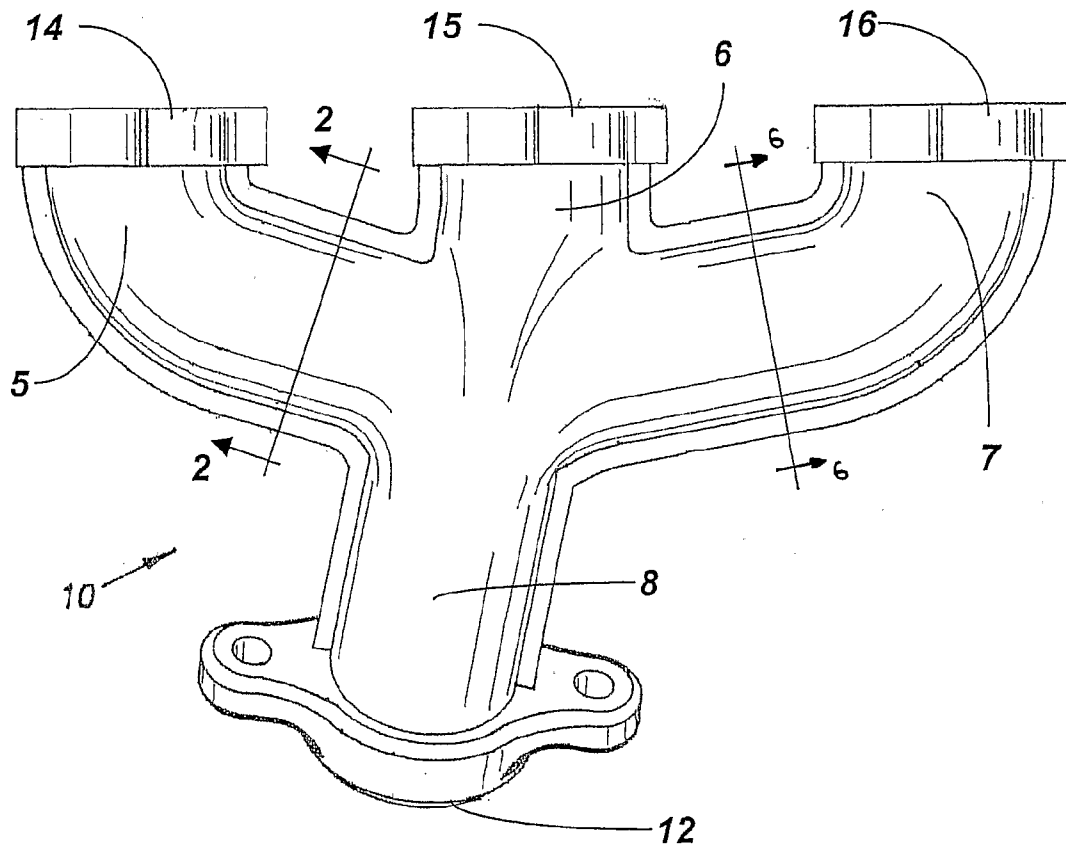

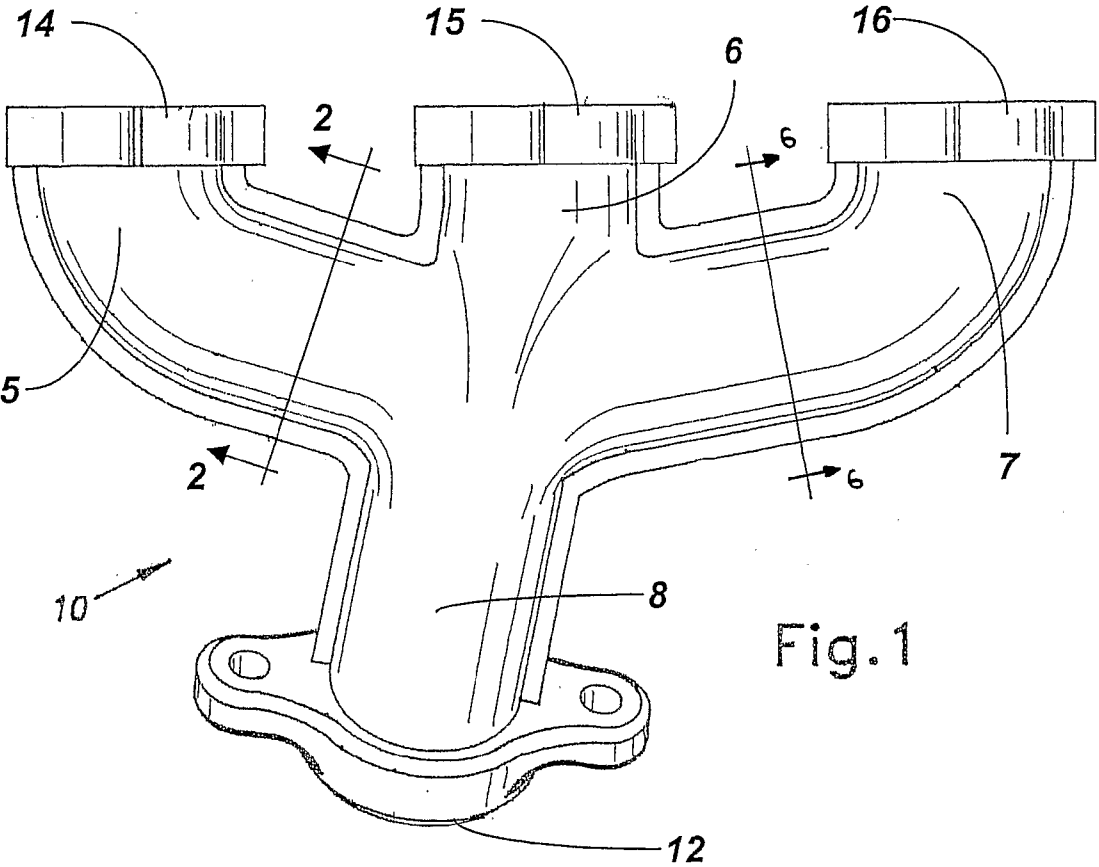

Fig. 1

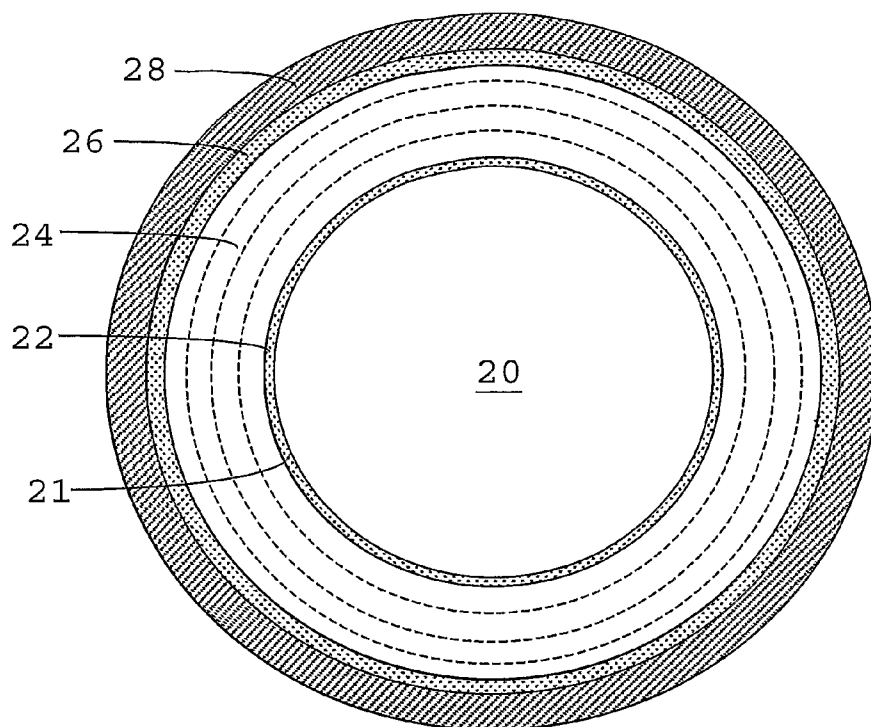

Fig. 2

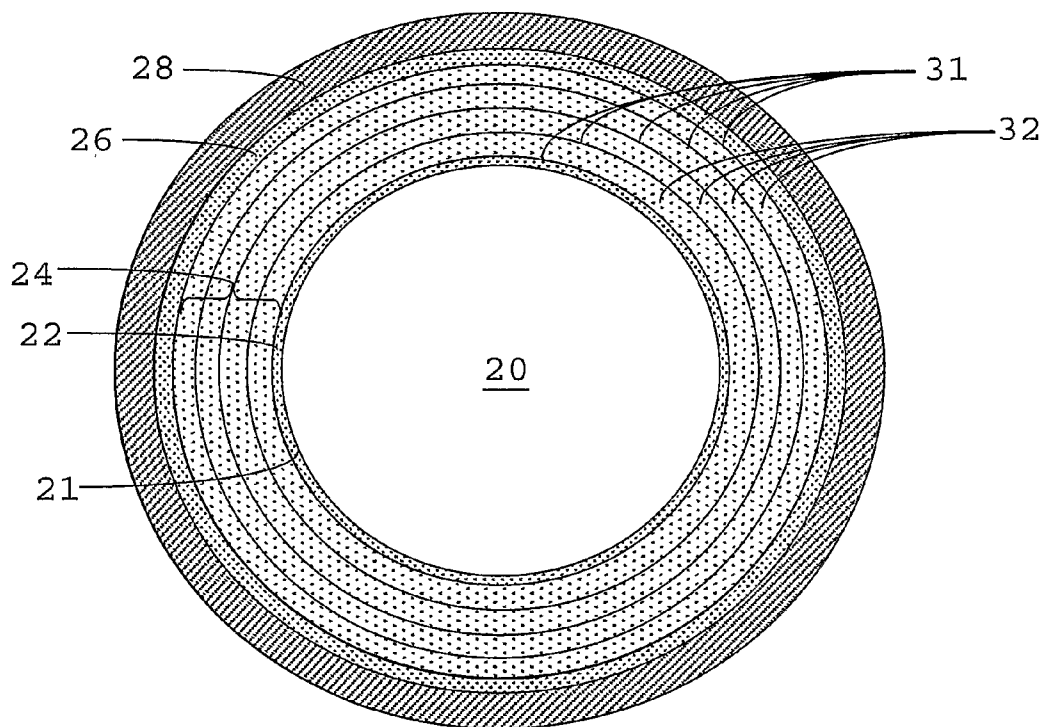

Fig. 3

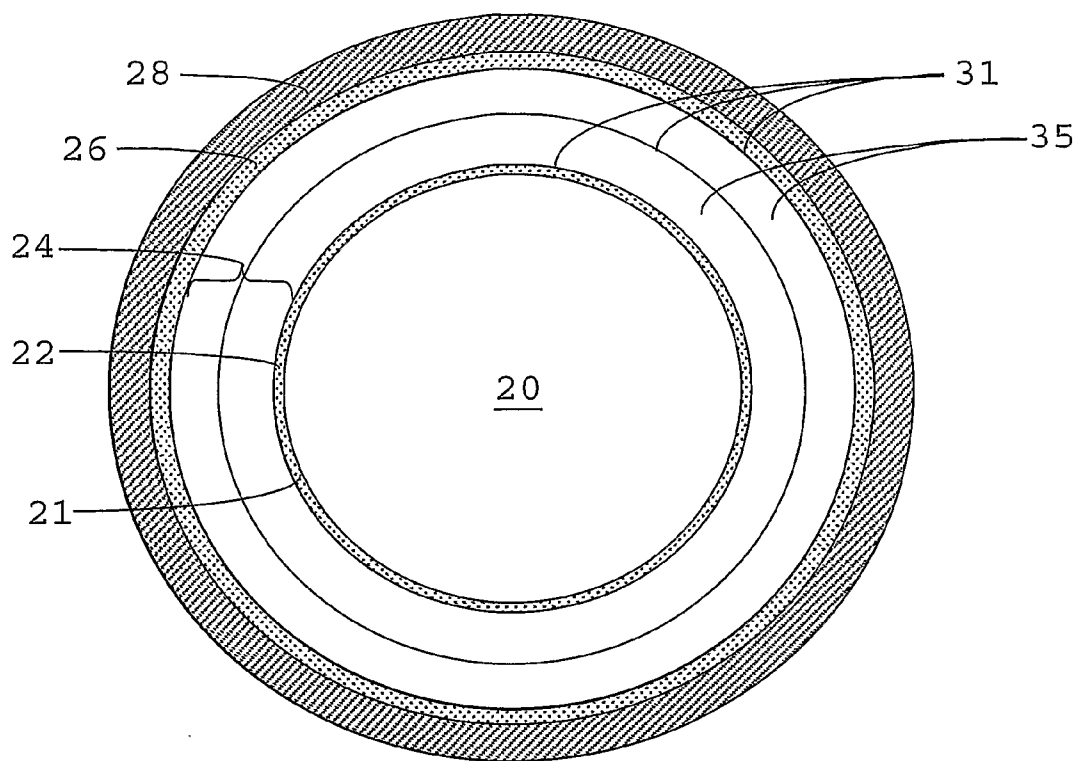

Fig. 4

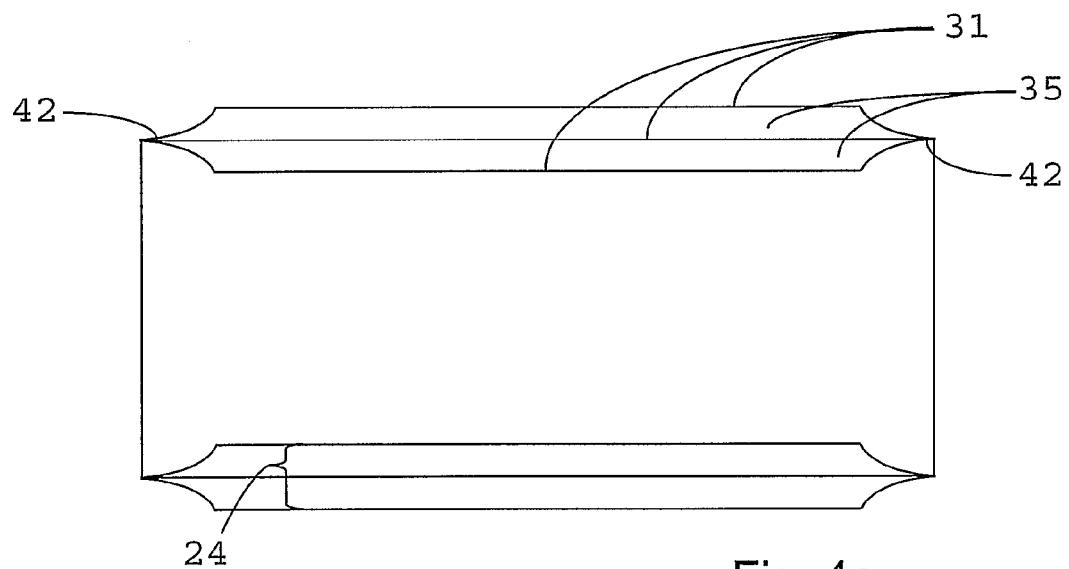

Fig. 4a

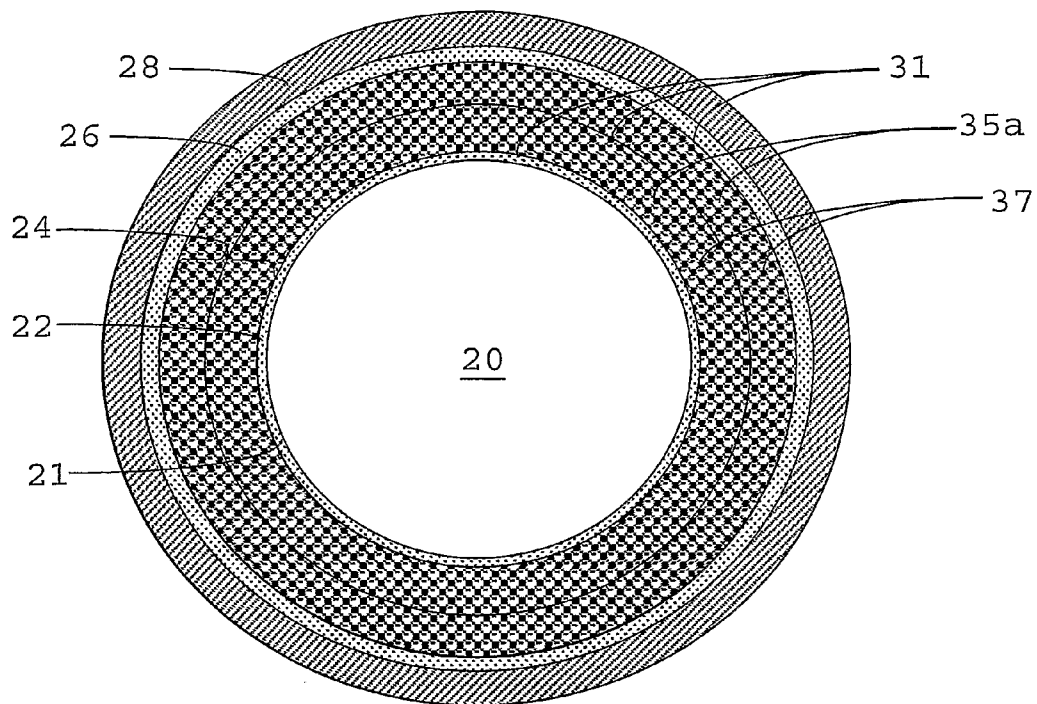

Fig. 5

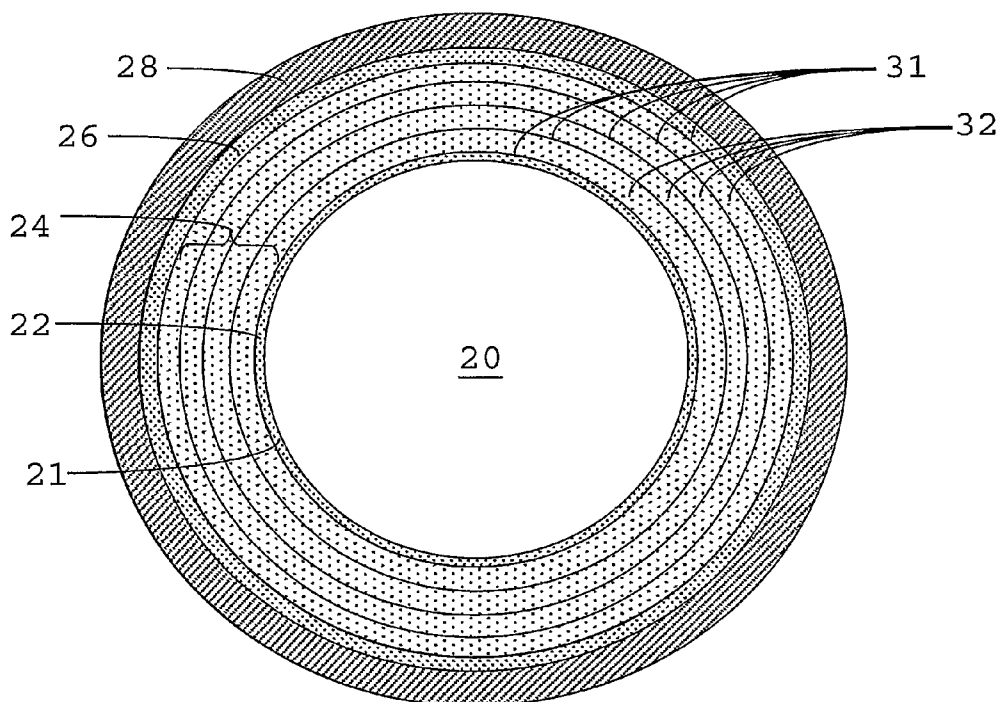

Fig. 6

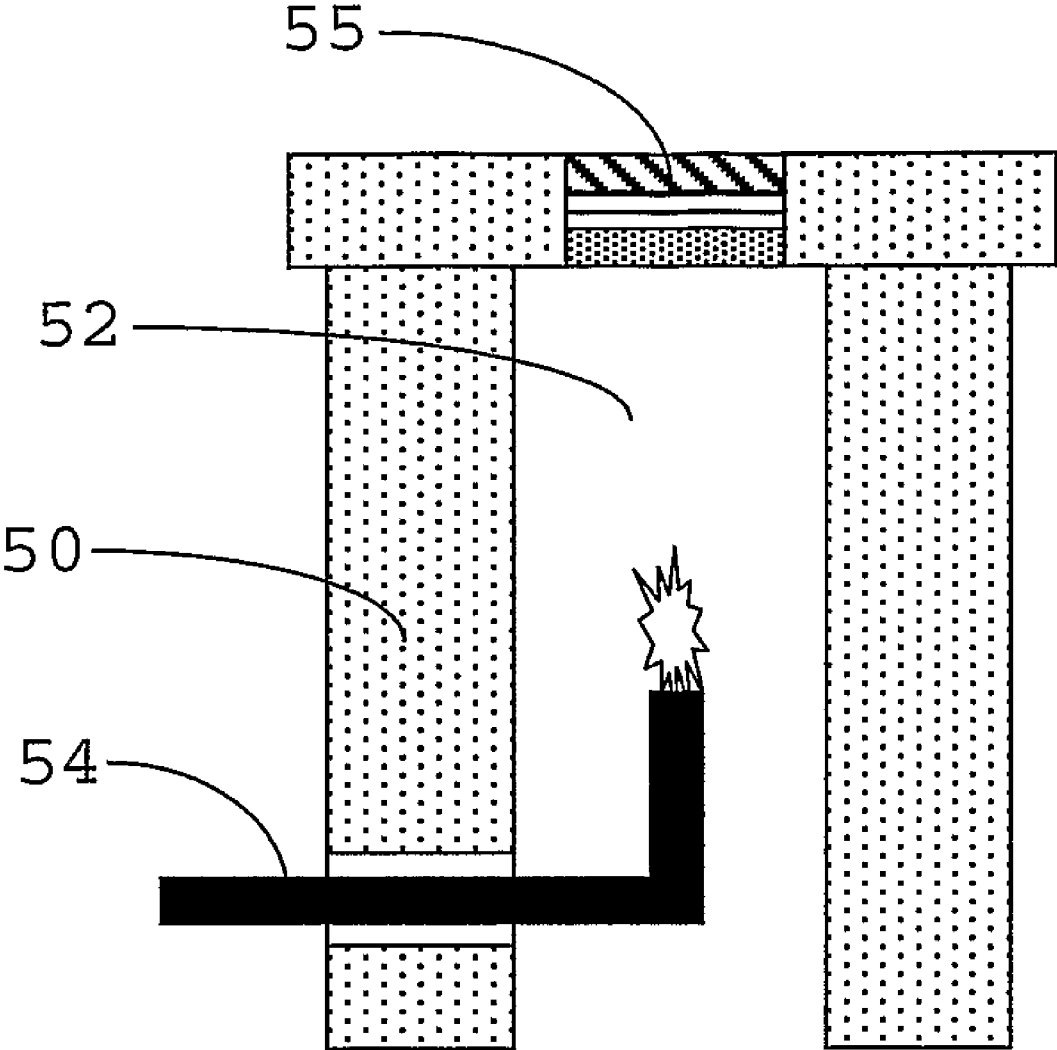

Fig. 7

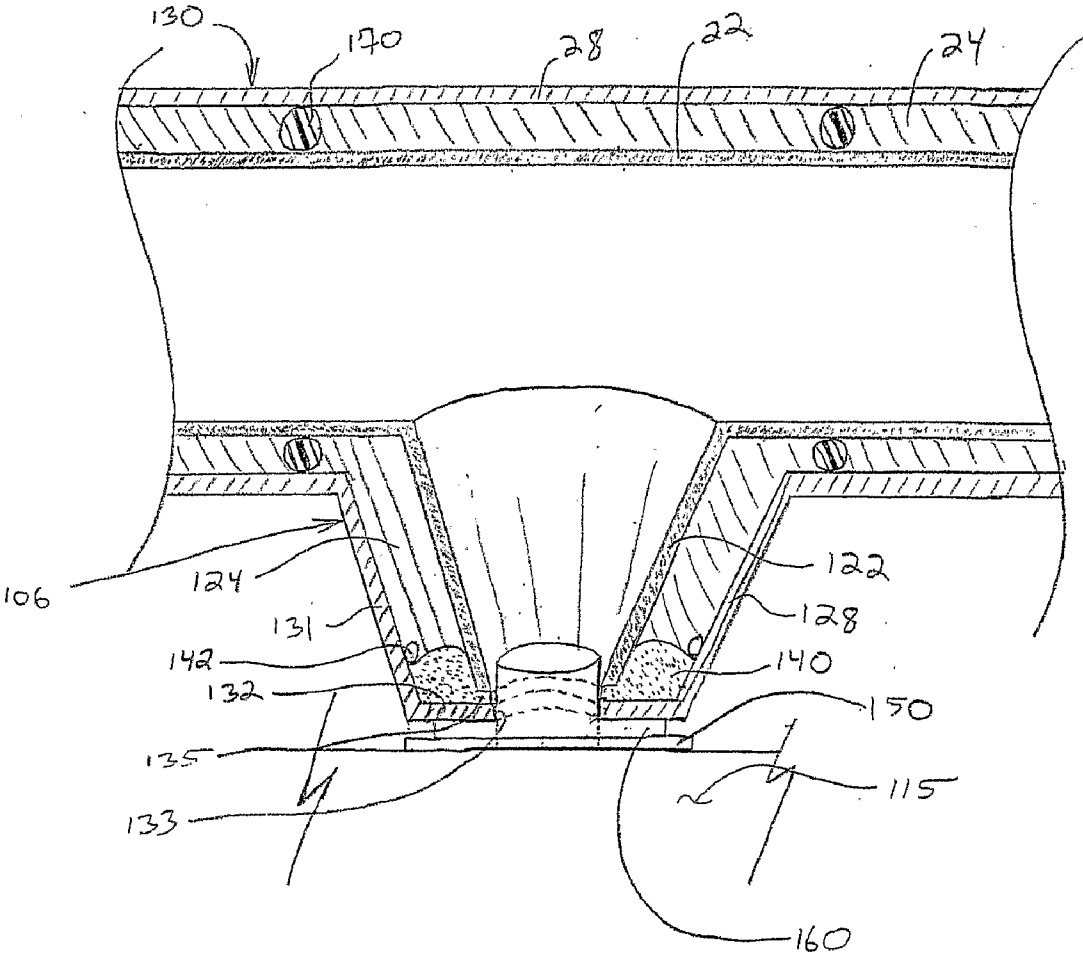

FIG 8

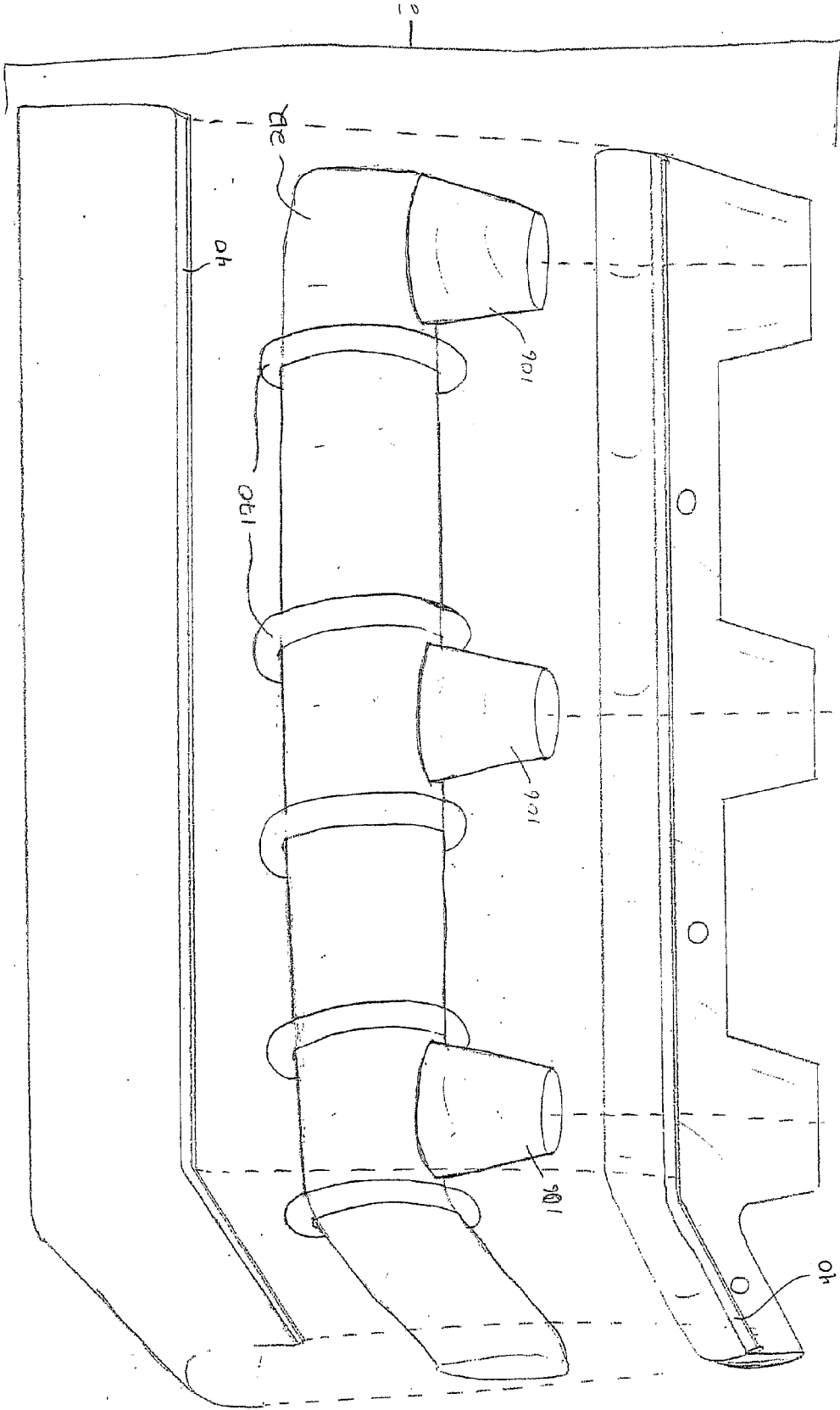

FIG 9

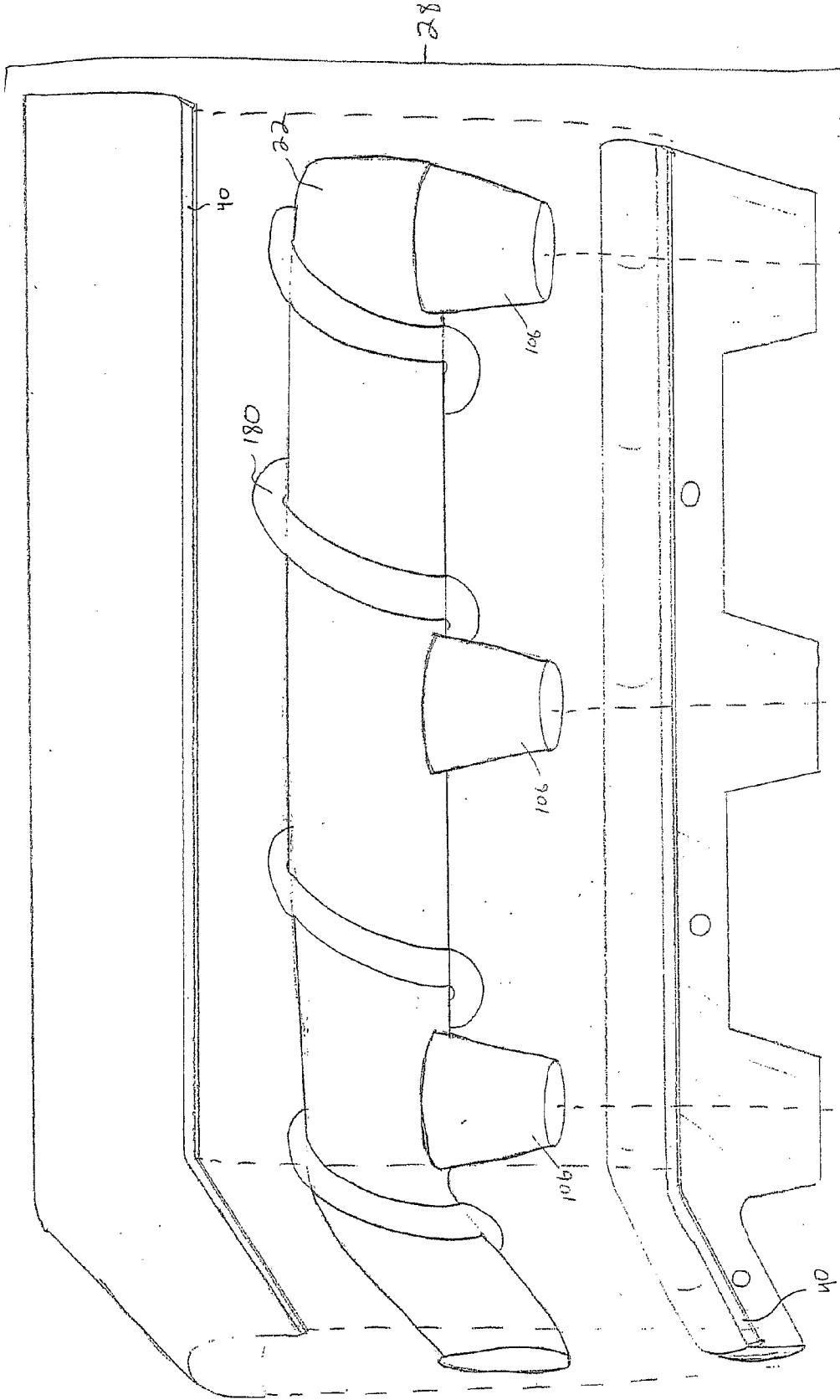

FIG 10ii

**HIGHLY INSULATED EXHAUST MANIFOLD**

[0001] This application claims the benefit of U.S. Provisional Patent Application Ser. No. 60/549,793 filed Mar. 3, 2004, and U.S. Provisional Patent Application Ser. No. 60/559,119 filed Apr. 2, 2004, the contents of both of which are incorporated herein by reference in their entirety.

**BACKGROUND OF THE INVENTION**

[0002] 1. Field of the Invention

[0003] The present invention relates to an exhaust manifold, and more particularly to a highly insulated exhaust manifold for an internal combustion engine.

[0004] 2. Description of Related Art

[0005] Catalytic converters in motorized vehicles, particularly passenger automobiles, must reach a certain temperature before they "light off." Light off occurs when the catalytic converter begins to convert harmful pollutants by oxidizing carbon monoxide and hydrocarbons to CO<sub>2</sub>, and reducing NO<sub>x</sub> to N<sub>2</sub> and O<sub>2</sub>. It is important to minimize the time to light off once a car is started to minimize the amount of harmful pollutants emitted to the atmosphere.

[0006] Catalytic converters typically are heated to light off by the high temperature engine exhaust gas itself. Unfortunately, the catalytic converter normally is mounted downstream of the exhaust manifold which conducts the heated exhaust gas from the engine. A typical exhaust manifold is made of metal, or substantially made of metal. Metal exhaust manifolds conduct and disperse thermal energy away from exhaust gas to the outside atmosphere. This loss in thermal energy reduces the exhaust gas temperature before it reaches the catalytic converter and delays light off.

[0007] Various techniques for insulating exhaust manifolds and/or for providing other means to speed up light off have been suggested and attempted. Cast iron exhaust manifolds are useful but heavy. Also, the mass (large thermal mass) of iron drains heat from the exhaust gas. Welded tubing exhaust manifolds have less mass, but are complicated and expensive. Double-walled welded tubing exhaust manifolds have been suggested, with an air gap between the walls, but the two walls have the same thickness and are both structural.

[0008] U.S. Pat. No. 5,419,127 teaches an exhaust manifold having inner and outer metal walls enclosing a layer of insulating material. Because the inner layer is metal and defines the wall of the exhaust gas pathway (i.e. it contacts the traveling exhaust gas), it conducts heat from the traveling exhaust gas thus delaying light off. In addition, the metal inner layer is subject to erosion or loss of integrity over time from thermal cycling.

[0009] U.S. Pat. No. 6,725,656 describes an insulated exhaust manifold having a ceramic inner layer and a ceramic insulation layer encased in a metallic outer structural layer. This arrangement has proven effective at substantially reducing the amount of heat conducted away from exhaust gases while traveling through the exhaust manifold on the way to the catalytic converter, resulting in reduced skin (outer surface) temperature for the manifold. However, it is desirable to reduce even further the skin temperature of the manifold.

**SUMMARY OF THE INVENTION**

[0010] An exhaust manifold is provided having a ceramic inner layer defining an exhaust gas passageway, a composite insulation zone disposed exterior to and adjacent the inner layer, and an outer structural layer disposed exterior to the composite insulation zone. The composite insulation zone includes at least one metallic foil layer.

[0011] An exhaust manifold also is provided having a main tube portion and at least one runner extending from the main tube portion, which has an inlet port located in a terminal end of the runner. The runner has a ceramic inner layer that is substantially encased within and spaced apart from a metallic outer layer, wherein the ceramic inner layer defines an exhaust gas passageway therein for conducting exhaust gas from the inlet port toward and into the main tube portion of the manifold. A sealing gasket is disposed and compressed between the ceramic inner and metallic outer layers at or adjacent the terminal end of the runner. The sealing gasket is encased within the metallic outer layer.

[0012] An exhaust manifold also is provided having a ceramic inner layer defining an exhaust gas passageway, an outer structural layer disposed exterior to the ceramic inner layer, and a strain isolation layer disposed intermediate the ceramic inner layer and the outer structural layer, wherein the strain isolation layer includes an intumescent mat.

[0013] An exhaust manifold also is provided having a ceramic inner layer encased within and spaced apart from a metallic outer layer thus defining an annular space therebetween. The manifold has a main tube portion and at least one runner extending from the main tube portion, wherein at least one O-ring gasket is provided and compressed in the annular space at a location in the main tube portion of the exhaust manifold.

**BRIEF DESCRIPTION OF THE DRAWINGS**

[0014] FIG. 1 is a top view of an exhaust manifold for conducting exhaust gas away from one side of a typical V-6 engine.

[0015] FIG. 2 is a cross-sectional view taken along line 2-2 in FIG. 1, showing an embodiment of the manifold having an inner layer, a composite insulation zone, a strain isolation layer, and an outer structural layer.

[0016] FIG. 3 is a cross-sectional view as in FIG. 2, wherein the composite insulation zone is composed of alternating discrete metallic foil and ceramic layers.

[0017] FIG. 4 is a cross-sectional view as in FIG. 2, wherein the composite insulation zone is composed of a plurality of metallic foil layers, with adjacent ones of the foil layers enclosing and defining substantially evacuated annular spaces therebetween.

[0018] FIG. 4a is a longitudinal cross-section of the composite insulation zone of FIG. 4 shown apart from the manifold, showing the individual metallic foils joined together along the circumference of their respective terminal edges, thereby defining the annular spaces in between adjacent foils.

[0019] FIG. 5 is a cross-sectional view as in FIG. 2, wherein the composite insulation zone is composed of at least one pair of opposing metallic foil layers enclosing and

defining an annular space therebetween, wherein the annular space is filled with substantially evacuated glass or ceramic microspheres.

[0020] FIG. 6 is a cross-sectional view taken along line 6-6 in FIG. 1, showing an embodiment of the manifold having an inner layer, a composite insulation zone and an outer structural layer, where the composite insulation zone has been provided with a plurality of intumescent tabs in openings made at discrete locations through the layers of the composite insulation zone.

[0021] FIG. 7 shows a schematic diagram, in cross-section, of a testing apparatus for testing the insulative properties of sample disc composites as further described in the examples hereinbelow.

[0022] FIG. 8 is a lateral cross-sectional view, shown partially in perspective, of an exhaust manifold runner mated or mounted to an associated cylinder head of an internal combustion engine for receiving exhaust gases therefrom, having a separate sealing gasket disposed internally of the metallic outer layer.

[0023] FIG. 9 shows a slip cast ceramic inner layer having an appropriate configuration as it is being enclosed within opposing metal clamshell halves to provide a metal-encased-ceramic exhaust manifold. O-ring gaskets are provided at strategic locations along the main tube portion of the ceramic inner layer.

[0024] FIG. 10 shows a slip cast ceramic inner layer as in FIG. 9, but having a ceramic rope wrapped in a helical configuration around the main tube of the ceramic inner layer as a spacer.

#### DETAILED DESCRIPTION OF PREFERRED EMBODIMENTS OF THE INVENTION

[0025] In the description that follows, when a range such as 5 to 25 (or 5-25) is given, this means preferably at least 5 and, separately and independently, preferably not more than 25. Also, as used herein an "extruded" portion of a layer, for example of a metallic or ceramic layer, refers to a portion of that layer that has the form of a hollow extruded solid. When referred to as a "circumferential portion," this means the extruded portion preferably has a circular or substantially circular cross-section. It is to be noted an "extruded" portion need not (and most likely will not) have been formed by the process of extrusion; it may be formed, e.g., via slip casting, metal casting or other suitable technique effective to produce hollow solids having a generally extruded form. Also, an "extruded" portion need not have a perfectly extruded form, such as a closed polygon or circle that has been extruded to form a perfect prism or cylinder; the term "extruded" portion is used merely for convenience to indicate a generally elongate portion of a layer of an exhaust manifold as hereinafter described. Also as used herein, an "annular" space refers to the space defined between adjacent but spaced apart concentric layers of an exhaust manifold. It is not necessary that the "annular" space be ring-shaped or cylindrical as for a true annulus, or that the concentric layers be truly parallel.

[0026] The term ceramic includes any inorganic compound, typically (though not necessary) crystalline, formed between a metallic (or semimetallic) and a nonmetallic element, and mixtures thereof; for example, alumina

(Al<sub>2</sub>O<sub>3</sub>), titania (TiO<sub>2</sub>), and boron nitride (BN), where Al and Ti are metallic elements, B is semimetallic, and O and N are both nonmetallic. Ceramics also include mixtures of ceramic compounds; i.e. soda-lime-silica glass is a ceramic composed of sodium oxide, calcium oxide and silicon oxide. As used herein, a ceramic (such as a ceramic layer, ceramic fibers or filler material, or any other ceramic component or material) can be and preferably is substantially ceramic; preferably comprising at least 80, preferably at least 85, preferably at least 90, preferably at least 92, preferably at least 94, preferably at least 96, preferably at least 98, wt. % ceramics as described in the preceding sentence, with the balance being additives and/or contaminants. Ceramics or ceramic materials include glasses, such as borosilicate glass, aluminosilicate glass, calcium aluminoborate glass, calcium aluminoborosilicate, and other known or conventional glass materials. Glasses are a special subclass of ceramic materials having an amorphous structure.

[0027] An exhaust manifold has at least one inlet and at least one outlet. With reference to FIG. 1, an exhaust manifold 10 is shown having three inlets or runners 5, 6 and 7 and one collector or outlet tube 8. Preferably, runners 5, 6, and 7 have inlet flanges 14, 15 and 16 respectively for mounting to exhaust ports in the engine block, and outlet tube 8 preferably has an outlet flange 12 for mounting to the exhaust pipe of an exhaust system. The manifold pictured in FIG. 1 is configured to conduct exhaust gas away from one side of a typical V-6 internal combustion engine. Exhaust gas from each of three cylinders on one side of the engine (not shown) enters that cylinder's corresponding runner 5, 6 or 7 in the exhaust manifold and exits the manifold through outlet tube 8. The outer surfaces of the inlet flanges preferably define a plane of assembly for mounting the exhaust manifold 10 to the head of the internal combustion engine. The inlet flanges 14, 15, and 16, and outlet flange 12 are all preferably made from cast iron or steel.

[0028] It will be understood that a manifold can be configured having, for example, 2, 4, 6, or any number of runners to accommodate engines having different numbers of cylinders (e.g. 4, 8, 12, etc.) and different configurations (e.g. in-line instead of V-oriented cylinders).

[0029] Referring to FIG. 2, manifold 10 is composed of multiple layers. In one embodiment, all the runners and the outlet tube have the same multiple layer construction. The manifold 10 has at least the following layers: inner layer 22, composite insulation zone 24, and outer structural layer (or outer layer) 28. Optionally and preferably, manifold 10 also has a strain isolation layer 26 disposed between outer layer 28 and insulation zone 24. The compositions and physical characteristics of each of the above layers will now be described.

[0030] Inner layer 22 defines an exhaust gas passageway 20 preferably having a diameter of 1-3 inches. Inner layer 22 is a dense ceramic layer or glaze that provides a smooth, nonporous or substantially nonporous, thermally resistant inner surface 21 for contacting hot exhaust gas as it passes through the manifold 10. The inner layer 22 is preferably composed of non-fibrous thermal shock resistant and erosion resistant dense ceramic, less preferably of ceramic fibers and a non-fibrous ceramic filler material. It is preferred that the non-fibrous dense ceramic is chosen from one or more of phases belonging to ceramic multi-component systems com-

prising alumina-silica-calcia-magnesia-titania. While oxide materials are usually cheaper to fabricate, it is also possible to consider a combination of non-oxide or oxide and non-oxide systems such as  $\text{Si}_3\text{N}_4$ , SiC, Si/SiC, Si/Si $_3\text{N}_4$  (e.g., the notation Si/SiC means silicon bonded SiC) and SiC— $\text{Si}_3\text{N}_4$ — $\text{Al}_2\text{O}_3$ — $\text{Y}_2\text{O}_3$ . The primary selection criterion is the thermal shock resistance under cyclic conditions when the engine is quickly turned to full power after it is allowed to be at ambient temperature. In the case of fibrous materials, the ceramic filler material preferably fills the void or interstitial space between the fibers, and coats the fibers. The ceramic fibers are preferably aluminosilicate fibers, less preferably silica fibers, less preferably alumina (such as Saffil from DuPont) or zirconia fibers, less preferably alumina-borosilicate fibers (such as Nextel from 3M), less preferably a mixture thereof. The above ranking of ceramic fibers is largely based on material cost and/or shrinkage under operating and processing conditions. Aluminosilicate fibers are presently the most widely available ceramic fibers (they are less expensive than alumina or zirconia) that are suitable to withstand the temperature ranges for many exhaust manifolds, typically 1600-1800° F. Any of the above fibers will perform adequately for most exhausts having a temperature of about 1600-1800° F. (i.e. automobile exhausts). Silica can withstand exhaust temperatures up to about 2100° F., while the more expensive alumina and zirconia fibers can withstand exhaust temperatures up to 2300° F. and beyond but are more expensive.

[0031] The ceramic filler material in inner layer 22 is selected to be stable or substantially stable against oxidation in strong oxidizing environments up to 1600, 1800, 2000, 2100, or 2300,° F., or greater, as the application requires. Material preference can be based on factors other than but not excluding performance. Such additional factors may include cost, ease of fabrication or incorporation into a particular manufacturing scheme, and thermo-mechanical compatibility with other constituents. Preferred ceramic filler materials suitable to withstand oxidation up to 2100° F. are alumina, mullite (aluminosilicate), silica, other metal oxides (e.g. titania, magnesia, or ceria), partially stabilized zirconia (PSZ), silicon carbide, silicon nitride, aluminum nitride, silicon boride, molybdenum disilicide, as well as borides, carbides, nitrides and oxides of refractory metals, and mixtures thereof. Included in these materials is a glass or glass-ceramic frit constituent of some of these components: alumina, silica,  $\text{B}_2\text{O}_3$ ,  $\text{P}_2\text{O}_5$ ,  $\text{TiO}_2$  and an alkaline earth oxide such as MgO, CaO or a mixture thereof. Less preferably, the ceramic filler material can be an alkaline oxide or transition metal oxide. Alkaline oxides and transition metal oxides may provide similar performance to alumina or silica filler materials in inner layer 22. Less preferably, the ceramic filler material in inner layer 22 is SiC,  $\text{SiB}_4$ ,  $\text{Si}_3\text{N}_4$ , or a mixture thereof. Such materials are even less preferred when the ceramic filler material in inner layer 22, particularly non-fibrous and crystalline ceramic, is in the sintered form. Less preferably, the ceramic filler material can be those glasses that may cause unacceptable dimensional changes in ceramic fibers, for example, when used in conjunction with silica or high silica fibers: glasses such as alkali containing calcium borosilicate glass, aluminosilicate glass, calcium aluminoborate glass, less preferably any other glass material capable of withstanding exhaust temperatures of 1200, preferably 1400, preferably 1600, preferably 1800, preferably 2100,° F. Less preferably, ceramic filler material

in inner layer 22 can be any other highly refractive ceramic material known in the art. The ceramic filler material preferably is provided as a ceramic powder (preferably colloidal when used as an inorganic binder) which, once it is fired, preferably forms into and fills the spaces between, preferably coating, the ceramic fibers. The ceramic fibers can be short fibers, long fibers, or a mixture thereof. Short fibers have a length of about 10-1000, preferably 20-100,  $\mu\text{m}$ , and long fibers have a length greater than 10,000  $\mu\text{m}$  (10 mm). Both long and short fibers preferably have a diameter of 0.1-20, preferably 0.15-10, preferably 0.2-5,  $\mu\text{m}$ .

[0032] Inner layer 22 is preferably 40-98, preferably 50-96, preferably 60-94, preferably 70-92, preferably 75-90, wt. % ceramic filler material, balance ceramic fibers. Inner layer 22 preferably has a porosity less than 20%, preferably less than 15%, preferably less than about 10%, with the localized porosity at the inner surface 21 of inner layer 22 being near zero or substantially zero, in any event less than 5, preferably less than 3, preferably less than 1, percent. It is important to have a very low or as low as possible (near zero) localized porosity at the inner surface 21 in order to provide a gas-tight or substantially gas-tight exhaust passageway 20, and further to provide a highly smooth surface to minimize frictional losses and pressure drop across the manifold 10. Inner layer 22 has a thickness of 0.05-8, preferably 0.08-3, preferably 0.1-2, mm. In the case of non-fibrous composition, inner layer 22 has a thickness of 0.05-10 mm, preferably 0.1-8 mm, preferably 1-6 mm.

[0033] The inner layer has low thermal conductivity and thermal diffusivity compared to metal. In addition, it is backed up by a highly insulating zone 24 as shown in FIG. 2 and described below. Consequently, the passing exhaust gas in passageway 20 retains a much greater proportion of its thermal energy rather than conducting/convecting it to the outer layers as heat.

[0034] In the embodiment illustrated in FIG. 3, the composite insulation zone 24 is a multi-layer zone composed of alternating layers of thin metallic foils 31 having ceramic insulating layers 32 disposed between adjacent ones of the foils 31. The foils 31 preferably are made from a highly reflecting or low emissivity metal or metal alloy, most preferably aluminum. By "highly reflecting," it is meant that majority of infra-red radiation is reflected and not transmitted. The most preferred case is 100% reflectance of infra-red radiation and 0% transmission or absorption. The next most preferred is at least 80% reflectance. By "low emissivity," it is meant that emissivity is less than 0.5 and preferably less than 0.3. According to published literature, polished aluminum typically has emissivity in the range of 0.1 to 0.2 even if it is oxidized at 1100° F. The presence of the foils 31 facilitates a substantial reduction in radiative heat transfer. The use of multiple foils 31 in the composite insulation zone 24 assures their effectiveness in the case of degradation of their properties under excessive heat, specifically for those foils at a temperature above 1100° F. The metallic foils preferably are 0.005-0.2 mm, preferably 0.01-0.1, preferably about 0.02-0.05, mm thick. Though it is preferred (for simplicity) that all the metallic foils 31 in the insulation zone 24 are made from the same material and have the same thickness, it is contemplated that different metallic foils 31 can be made from different metals or have different thicknesses. For example, based on the reflectance and/or emissivity properties of different metals, one may select combi-

nations of foils 31 to provide an insulating zone 24 having insulating properties that are particularly suited or adapted to a specific application, exhaust gas temperature, or desired outer surface or "skin" temperature. Foils 31 closer to the inner layer 22 may be selected from high temperature oxidation resistant alloys such as polished nickel or cobalt alloys, while foils closer to outer layer 28 may be aluminum or aluminum alloys. Determination and selection of further combinations of metallic foils 31 as described herein can be made for a specific application by persons of ordinary skill in the art without undue experimentation.

[0035] The ceramic insulating layers 32 in the composite insulation zone 24 preferably are composed of ceramic fibers and/or non-fibrous (preferably colloidal) ceramic filler material similarly to the inner layer 22. In the insulating layers 32, ceramic fibers can be provided in the form of a ceramic paper as known in the art; non-fibrous or colloidal ceramic particles can be provided, e.g., in the form of a suitable particle suspension such as a ceramic paste. The ceramic fibers and filler material used in the ceramic insulating layers 32 can be the same materials as inner layer 22, except for a given insulating layer 32 they are combined in different ratios compared to the inner layer 22. In the insulating layers 32, fibers make up 65-99, preferably 70-96, preferably 75-94, preferably 80-92, preferably 85-90, wt. % of the layer, with the balance being ceramic filler material. Alternatively, the ceramic insulating layers 32 can be provided having substantially 100% ceramic fibers with no or substantially no filler material.

[0036] Preferably, the ceramic fibers in each of the insulating layers 32 are silica fibers, alumina fibers, or aluminosilicate (or boroaluminosilicate) fibers of sufficiently high alumina content, preferably 40-99, more preferably 50-90, more preferably 55-80, most preferably 60-75, wt. % alumina. High alumina content in the insulating layers 32 enables the composite insulation zone 24 to resist shrinkage at high temperature. Alternatively, high purity silica fibers may be used if the manifold 10 is to be used with lower temperature exhaust such that the resulting shrinkage of insulation zone 24 will not be greater than 0.5%. The insulating layers 32 preferably have a porosity of 20-95, preferably 40-90, preferably 60-90, preferably 70-90, preferably about 75-85, percent. This high porosity is achieved by increasing the ratio of ceramic fibers to filler material as compared to inner layer 22.

[0037] It is possible to use ceramic filler material having a high level of microporosity, thereby increasing the thermal resistance, and consequent insulation capacity, of the layers 32. For example, silica in the form of silica aerogel particles can be used to fill interfiber spaces to improve insulating characteristics of the layer. The composite insulation zone 24 preferably has an overall thickness of 1-40, preferably 2-30, preferably 2-20, mm, including all of the metallic foil 31 and ceramic insulating layers 32 therein.

[0038] The ceramic insulating layers 32 preferably are rigidized to promote dimensional stability and erosion resistance. Rigidization is preferably achieved with one of the following rigidizers: colloidal silica or silica precursor, colloidal alumina or alumina precursor, finely divided glass frit, or a mixture thereof. Where one of the above (or another) rigidizer is used as the ceramic filler material in a layer 32, no additional rigidizer is required. Where a non-

rigidizer is used as the ceramic filler material in a layer 32, that layer preferably also contains 1-15, preferably 3-12, preferably 4-10, preferably 5-8, preferably about 6, wt. % rigidizer. In a further embodiment illustrated in FIG. 4, each pair of metallic foils 31 in the insulation zone 24 encloses and defines a substantially evacuated annular space 35 between the adjacent foils. As seen in the figure, adjacent pairs of foil layers can share a foil layer in common, e.g., yielding the illustrated construction:

[foil][evacuated space][foil][evacuated space][foil]

In this embodiment, spacers, e.g. in the form of periodically spaced annular rings of suitable thickness, may be provided in the evacuated spaces 35 to maintain the separation of adjacent metallic foil layers and the integrity of the respective evacuated annular spaces 35. Cylindrical sections of the insulation zone 24 can be made according to this embodiment by joining cylindrical metallic foils 31 around the circumference of their respective terminal edges as shown in FIG. 4a, and then evacuating the thus-defined annular spaces between the foils via known or conventional techniques. The foils can be joined, e.g., by brazing or welding their circumferentially extending terminal ends 42 together to create a circumferential weld-seam between the foils that is substantially air-tight and effective to maintain a vacuum in the annular spaces 35. Each space 35 preferably is filled with insulating ceramic material selected from those materials described for the inner layer 22. In addition, the spaces 35 may also be filled with loose ceramic powder (the term "loose" means no binder is provided, the powder particles are uncohered) with low intrinsic thermal conductivity such as aerogel particle of silica, fumed silica, stabilized and expanded vermiculite having fine pores, etc.

[0039] FIG. 5 illustrates a further embodiment in which a microsphere layer 37 is disposed between adjacent metallic foil 31 layers. Each pair of opposing metallic foil 31 layers defines an annular space 35a between the foils. The annular space is filled with substantially evacuated hollow glass or ceramic microspheres to provide the highly evacuated microsphere layer 37 in between adjacent metallic foils 31 in the composite insulation zone 24. As discussed below, the use of evacuated microspheres makes it easier to provide substantially evacuated spaces in the composite insulation zone 24 without having to evacuate annular spaces between metallic foil 31 layers. Such an arrangement results in the effective thermal conductivity of the microsphere layer 37 being less than that of a stagnant air layer of equivalent dimensions. Such a layer of stagnant air has been reported to have thermal conductivity of about 0.02 BTU/hr-ft-° F. Preferably, the microspheres are in the range of 10-1000, preferably 100-500 (+/-10%) microns in diameter having a composition substantially belonging to the system of Al<sub>2</sub>O<sub>3</sub>-SiO<sub>2</sub>-Alkaline Earth Oxide (CaO, MgO, etc) including fused silica with a softening point greater than 2000° F. and preferably 25000° F. Suitable microspheres are commercially available from Hy-Tech Thermal Solutions, L.L.C., Melbourne, Fla., USA. The microspheres in the microsphere layer 37 can be, and preferably are, loosely packed in the annular space 35a between adjacent foils 31. By loosely packed, it is meant that the microspheres essentially are poured or injected into the annular space 35a sufficient to fill the space between the foils, but are not adhesively bound to one another or to the foils 31, e.g. using any sort of binder. Loosely packed does not necessarily

mean that the microspheres are not packed tightly or crammed in the annular space 35a (they can be), only that no adhesive or binder is used to cohere them. Less preferably, the microsphere layer 37 can include a binder, such as a ceramic binder material, effective to provide a cohesive microsphere layer 37 in the annular space 35a. Use of a binder is less preferred because the binder itself may reduce flowability of microspheres, making it more difficult to pack them in the annular space 35a. Preferably, to ensure maximum evacuated volume, microspheres are packed as tightly as possible into the annular space 35a to provide the microsphere layer 37.

[0040] The evacuated annular space 35 described above and illustrated in FIG. 4 has better insulating properties than the microsphere layer 37 described in the preceding paragraph because the evacuated annular space 35 has a lower thermal mass than the microsphere layer 37. However, the microsphere layer 37 may be preferred because it is easier to make and provide in the manifold 10 from a manufacturing standpoint; i.e. it is not required to join the metallic foils 31 circumferentially at their terminal edges because the microsphere layer 37 does not depend on a hermetic air tight seal. Instead, the microsphere layer 37 approximates an evacuated space or layer because the internal volumes of the microspheres themselves are evacuated or at substantially reduced pressure as a result of the process by which they are manufactured. Thus, a substantial proportion of the volume of the microsphere layer 37 is evacuated or maintained at substantially reduced pressure. Further, the microsphere walls are made from ceramic material and consequently are poor conductors of heat.

[0041] The composite insulation zone 24 can be or comprise a combination of any or all of the above-described layers having insulating properties, in alternating arrangement with the metallic foils 31. For example, the composite insulation zone 24 can include a ceramic insulating layer 32, a microsphere layer 37, an evacuated annular space 35, or any combination of these in alternating arrangement with and separated by metallic foils 31. Appropriate combinations of these layers in the composite insulation zone 24 can be determined and selected by a person of ordinary skill in the art without undue experimentation based on a particular application.

[0042] The composite insulation zone 24 is effective to insulate the exhaust gas traveling through passageway 20 adjacent inner layer 22 such that the gas retains at least 80 preferably 85, preferably 90, preferably 95, percent of its initial thermal energy (or temperature) on exiting the manifold 10.

[0043] The strain isolation layer 26 is an optional layer is disposed exterior to and adjacent, preferably in direct contact with, the outer surface of the composite insulation zone 24. Strain isolation layer 26 is disposed between the composite insulation zone 24 and the outer layer 28. Strain isolation layer 26 is a very thin layer, preferably 0.05-3, more preferably 0.1-2, mm thick, and is preferably made of ceramic fibers and/or ceramic filler material. Preferably, strain isolation layer 26 is composed of the same or similar ceramic fibers as the inner layer 22. However, the ceramic filler material in isolation layer 26 is chosen to be metal resistant; i.e. to resist seepage of molten metal during application or casting of outer structural layer 28 which is

preferably a metal layer as will be described. The preferred metal resistant ceramic filler material in strain isolation layer 26 depends on the metal used for outer layer 28. If outer layer 28 is a ferrous metal layer (i.e. steel), then zirconia, alumina, boron nitride, zircon (zirconium silicate  $ZrSiO_4$ ), or a mixture thereof is the preferred ceramic filler material for layer 26. If aluminum or an aluminum alloy is used for outer layer 28, then the preferred ceramic filler material for isolation layer 26 is alumina, boron nitride, calcium aluminoborate glass, calcium aluminoborosilicate, calcium aluminate cement or a mixture thereof. When boron nitride is used (preferably with a ferrous metal outer layer 28), the boron nitride is preferably applied via spray coating, dipping, or other similar means. Boron nitride is preferably applied as a slurry of boron nitride and a liquid such as water, preferably having ceramic fibers as described above dispersed therein. Strain isolation layer 26 has 70-99, preferably 80-90, wt. % ceramic fibers, balance filler material. When boron nitride, zircon, alumina and mixtures containing them are used for the isolation layer, ceramic fibers may not be required but are preferred. Layer 26 is a compliant layer and is not rigidized.

[0044] Alternatively, the strain isolation layer is an intumescent mat. The intumescent mat is composed of ceramic fibers, an expandable material and a binder material, wherein the basic construction is that of a highly porous, compliant and resilient fibrous mat. The binder is present in an amount effective to bind the ceramic fibers and the expandable material together in the mat construction to provide a coherent fibrous mat. Suitable binder materials include organic binders such as methyl cellulose ether, less preferably starch, less preferably polyvinyl acetate or polyvinyl butyrol, less preferably another known organic binder, less preferably a mixture thereof. Less preferably the binder can be a mixture of organic and inorganic binders. The expandable material preferably is in the form of embedded particles of vermiculite, perlite, or combinations thereof, which are dispersed throughout the fibrous mat. Vermiculite is a naturally occurring mineral, a member of the phyllosilicate group. Perlite is a naturally occurring siliceous rock or volcanic glass. Each of these materials exhibits the unique property of expanding many (i.e. 4-20) times on heating. Preferably, the fibrous mat has the following composition by weight: 20-60, preferably 25-50, preferably 30-45 weight percent ceramic fibers, 35-75, preferably 40-65, preferably 45-60 weight percent vermiculite or perlite (or combination) particles, balance ceramic filler or binder material. The binder has the effect of constraining the fibers in their resting orientation or state, resulting in the intumescent mat being resilient (or rebounding) following external compression or expansion of the mat. Conversely, the vermiculite particles expand in volume on being heated, and the expansion of the dispersed vermiculite particles tends to cause the intumescent mat to expand on heating. The result of these competing effects is a compliant, resilient intumescent mat that expands on heating, and contracts or rebounds substantially back to its initial (unexpanded or substantially unexpanded) state on cooling. The expanding/rebounding property of the intumescent mat will be maintained so long as the mat is not heated above the temperature at which the binder is baked off. Once this temperature (referred to as the crossover temperature) has been reached, the binder is depleted from the mat and the force tending to constrain the expansion of the ceramic fibers is removed. Therefore, above the crossover tempera-

ture the intumescent mat irreversibly expands from the heat-induced expansion of the dispersed vermiculite (or perlite) particles; on cooling the mat will no longer contract or rebound to its initial state because the contracting/binding influence of the binder material has been removed. Once the intumescent mat has been cycled once above the crossover temperature, it will no longer rebound from an expanded state.

[0045] If the crossover temperature is likely to be exceeded (e.g. during operation of the manifold 10) then the thickness of the intumescent mat should be adjusted so that after binder burn-off and consequent expansion of the vermiculite, the inner layer 22 is subjected to a modest compression so that it will not be damaged. Under these conditions, if the metallic outer layer 28 expands relative to ceramic inner layer 22, expansion of the intumescent mat is accommodated by the expanded outer layer 28 resulting in reduced compression at the inner layer 22. It is important to select the temperature (the reference temperature) at which the metallic outer layer 28 and the ceramic inner layer 22 are assembled, and their relative expansion coefficients. By judicious selection of materials and adjusting effective expansion coefficients, thermal mismatch can be reduced. For example, a cast manifold undergoes a large temperature excursion during fabrication (as determined by the melting point of the metal) and hence there is a greater likelihood of expansion/contraction mismatch once the cast outer layer 28 cools. On the other hand, if the outer layer 28 is provided as an assembly of two split-molded or clamshell molded halves assembled around the inner layers at or near room temperature, the outer layer 28 is less likely to exhibit so great a thermal mismatch with the inner layer 22.

[0046] For example, aluminum is cast at a temperature in the range of 600-650° C., while its temperature during use as the outer layer in a manifold disclosed herein would be much less, e.g. 200-300° C. Therefore, for a manifold whose metal outer layer 28 is assembled at room temperature, the outer layer 28 is likely to be expanding by 200-300° C. (operating temperature for the outer layer 28); whereas for a cast metallic outer layer 28, the outer layer would not exhibit any substantial thermal expansion below the casting temperature of 600-650° C., which it will not reach due to the highly insulative properties of the composite insulation zone 24.

[0047] Therefore, when an intumescent mat is used for the strain isolation layer 26, its expansion-contraction properties and its thickness relative to (a) the gap between the concentric outer layer 28 and the insulation zone 24 and (b) the anticipated thermal excursions due to the fabrication process for the outer layer and the manifold operating conditions, should be taken into account in intumescent material selection.

[0048] The intumescent (expansion-contraction) property of the intumescent mat is advantageous because as the manifold heats up or cools down with respect to a reference temperature determined by the fabrication process, expansion of the metallic outer layer 28 and the various ceramic inner layers (22 and 32) can occur at different rates. The intumescent mat allows for and can accommodate large changes in the relative displacement of these layers through its reversible expansion-contraction characteristics over a large fraction of the mat's original thickness. For example,

a 2 mm thick intumescent mat layer 26 that exhibits a 50% reversible change in displacement on heating/cooling can fill the space between the outer layer 28 and insulation zone 24, and provide effective support even if the spacing between the layer 28 and zone 24 varies from 1 to 3 mm due to thermal mismatch.

[0049] Strain isolation layer 26 absorbs or dampens vibrational stresses from the engine and from road harshness. Layer 26 also accommodates the unmatched thermal expansion characteristics of outer layer 28 and insulation zone 24. Because layer 28 is preferably made of metal, and the insulation zone 24 can include ceramic layers 32, the outer layer 28 has a much higher coefficient of thermal expansion than insulation zone 24 (typically about or at least twice as high). Consequently, the expansion and contraction of outer layer 28 due to thermal cycling may cause the ceramic layers in the composite insulation zone 24 to fracture in the absence of a compliant strain isolation layer 26. Even when ceramic insulating layers 32 are not used, the strain isolation layer 26 still prevents or minimizes mechanical stresses from the outer layer 28 from being transferred ultimately to the ceramic inner layer 22 which may be damaged or crack under mechanical stress.

[0050] In the absence of a strain isolation layer 26, intumescent tabs 38 can be provided in openings 44 made at discrete locations through the layers of the composite insulation zone 24 (see FIG. 6) in order to stabilize the inner layer 22 relative to the outer layer 28 through thermal cycling of the exhaust manifold 10. In addition, if a strain isolation layer 26 is absent, the intumescent tabs 38 dampen mechanical vibrations or stresses between the outer layer 28 and the inner layer 22. Such damping helps ensure the inner layer 22 of the manifold is not damaged or cracked from mechanical stresses as described in the preceding paragraph. The intumescent tabs 38 can be made or cut from the same material as the intumescent mat previously described.

[0051] As indicated above, outer layer 28 is a structural layer and preferably is made from metal. Layer 28 can be a metal-containing layer or a metal composite layer. Metal-containing materials and metal composites are generally known in the art. Preferably, a metal composite layer contains ceramic filler material such as SiC, alumina, or a mixture thereof. Outer layer 28 is disposed exterior to and adjacent the strain isolation layer 26 if present. In the absence of a strain isolation layer, outer layer 28 is disposed exterior to and adjacent the insulation zone 24. An outer metal layer provides mechanical and impact strength, and ensures gas-tightness of the exhaust manifold. Preferably, outer layer 28 is made of a ferrous metal, preferably cast ferrous metal or metal alloy such as steel. Less preferably, outer layer 28 is made from aluminum, less preferably any other suitable metal or metal alloy known in the art. Aluminum conserves weight, but may be subjected to creeping under stress from an applied load. This is why a ferrous metal (such as steel) outer layer 28 is preferred. However, aluminum can be used advantageously if steps are taken to avoid excess loading of the manifold to maintain stresses below the creep threshold, i.e. with brackets to support the manifold. Preferably, the outer layer 28 is 1-25, preferably 2-20, preferably 5-15, mm thick.

[0052] An exhaust manifold having a ceramic inner layer 22, a composite insulation zone 24, a strain isolation layer 26

and a metal outer layer **28** can be made as follows. The inner layer **22** is made first by slip casting the inner layer **22** in the appropriate configuration for the desired manifold; i.e. having the appropriate piping configuration, number and placement of runners, etc. Slip casting techniques are very well known in the art and will not be described further here, except to describe the preferred slip casting composition. The slip casting composition, also called "slip" preferred for use herein is a fused silica based slip composition. Such a fused silica slip composition is available from Industrial Ceramic Products, Marysville, Ohio. The slip composition is used to produce the layer **22** such that after firing, it is resistant to thermal shock, dimensional changes at elevated temperatures and high velocity gases.

[0053] The metallic outer layer **28** is prepared as two clamshell halves that can be suitably joined, e.g. along mating perimeter flanges **40** provided on each half (see FIGS. **9** and **10**). Alternatively, the halves can be suitably joined by welding as known in the art. Prior to joining the clamshell halves, the strain isolation layer **26** (if present), composite insulation zone **24** and previously slip cast inner layer **22** are prepared and assembled together in the appropriate order, and placed within the volume of one of the clamshell halves such that the other clamshell half of the outer layer **28** can be fit thereover, enclosing all the constituent layers to form the manifold **10**. Then the clamshell halves are suitably joined by a conventional technique to provide the finished exhaust manifold **10**. Alternatively, if a metal seepage-resistant strain isolation layer is used, the inner layer **22**, insulation zone **24** and strain isolation layer **26** can be constructed and assembled, and then used as a mold core for casting the outer metal layer **28** directly thereto.

[0054] To make the composite insulation zone, at least one metallic foil **31** is coated on one of its surfaces with ceramic fibers, hollow micro-spheres, ceramic binder, ceramic particulates etc., depending on the desired construction for the insulation zone **24**. The coating can be provided as an appropriate slurry or paste having the desired combination or ratio of fibers to filler material or other insulating components as described above. Such ceramic slurries are well known in the art, and typically contain from 1 to 2 percent by weight solids, balance water. A second metallic foil is then provided over the coating on the first foil surface to provide a sandwich composite. This composite is then folded to conform to the proper shape and contour within the outer layer **28** clamshell half, between the inner layer **22** and strain isolation layer **26** (if present) prior to fitting the second outer layer **28** clamshell half to complete the manifold. Additional layers of foil/ceramic can be provided if it is desired to provide a composite insulation zone **24** having multiple ceramic insulating layers **32**. Once the manifold is assembled, it is heated to bake off the water or other volatiles from the ceramic slurries thus leaving behind the insulating material. If evacuated annular spaces **35** are to be used, the metallic foils are formed into concentric cylindrical forms and their terminal circumferential edges are joined as described above and illustrated in FIG. **4a**, around the inner layer **22**. For simplicity of construction in this embodiment, the composite insulation zone can be made in a plurality of discrete sections which are separately and adjacently fitted around the slip cast inner layer **22**. If a microsphere layer **37** is to be used, then adjacent metallic foils **31** can be assembled to provide the composite insulation zone **24**, and

then microspheres injected into the intermediate annular space **35a** between adjacent metallic foils.

[0055] In a further embodiment, a catalyst belonging to a family of inorganic compounds,  $ABO_z$  where O is oxygen, is added to the inner surface **21** of the inner layer **22**. Preferably the catalyst has either a perovskite structure (with A being a rare earth element and an alkaline earth element, and B being a transition metal element), or a fluorite structure (with A being a rare earth element and B being Ce or Zr). For a perovskite catalyst, A is preferably La and Sr, and B is preferably Fe, Co or Mn, less preferably Ti, Ga, Cr, or Ni. For a fluorite catalyst, A is preferably a rare earth metal such as Gd or Y and less preferably alkaline earth metal such as Ca or Mg. When the  $ABO_z$  catalyst has a perovskite structure z is 2-5; when it has a fluorite structure z is 1-4.

[0056] Other known catalysts, such as partially substituted  $BiMoO_3$  and Gd-doped  $CeO_2$ , also can be used. Such a catalyst preferably is activated at a lower temperature than the platinum and palladium catalysts typical of most catalytic converters, and can begin to convert CO and  $NO_x$  to  $CO_2$  and  $N_2$  and  $O_2$  during the period prior to light off after a vehicle is started. The catalyst preferably is provided as finely divided (preferably colloidal) particles, and can be added to the inner layer slip prior to slip casting thereof. Preferably, the catalyst particles are 0.1-5, preferably 0.5-4, preferably 1-3, wt. % of the total solids in the inner layer slip.

[0057] In addition to unmatched thermal expansion, another issue related to metal-encased-ceramic type exhaust manifolds is the need to provide an appropriate gas-tight seal between the inner ceramic and outer metallic layers. This is particularly important adjacent the manifold inlet and exit ports, for example at the lip of the runner inlets where high temperature exhaust gas flows at high pressure out from the cylinder head of an engine and into the manifold. At these locations, an improper or low integrity seal between the metallic and inner ceramic layers will permit hot exhaust gases to enter the annular space between those layers where the gases can damage or potentially oxidize insulation material. In addition, exhaust gas in this annular space may not be conducted into the catalytic converter before being emitted to the atmosphere, thus increasing harmful emissions.

[0058] FIG. **8** shows, in cross-section, a runner **106** of an exhaust manifold **110** mated or mounted to an associated exhaust port of a cylinder head **115** (shown schematically in FIG. **8**) in order to receive hot exhaust gases therefrom during engine operation. In this embodiment, the runner **106** is formed from metallic outer layer **128** and ceramic inner layer **122** generally as described above, except that they are dimensioned and configured as follows. To form the runner **106**, the outer layer **128** has a metallic extruded portion **131** (preferably in the form of a circumferential portion) that extends radially from the main tube portion **130** of the outer metal layer of the manifold, with an inwardly extending (preferably circular) flange portion **132** located at its terminal end. The inwardly extending flange portion **132** can be formed integrally with extruded portion **131** when the outer layer **128** (or its clamshell half) is cast. The flange portion **132** extends inward and defines a preferably circular opening or inlet port **133** for the runner **106**.

[0059] The ceramic inner layer 122 of the runner 106 also has a substantially extruded configuration, and extends from the main tube portion of the ceramic inner layer, extending concentrically within the metallic extruded portion 131 of the outer layer 128 toward the inlet port 133 or flange portion 132. The ceramic extruded inner layer 122 of the runner 106 approaches but does not contact the flange portion 132, leaving a small gap 135 between the terminal end of the inner layer 122 and the flange portion 132. In the illustrated embodiment, the extruded (preferably circumferential) portions of both the outer and ceramic inner layers 131 and 122 are conically shaped, with the reduced diameter portions located distal from the main tube of the manifold 110 adjacent the inlet port 133. This construction may be preferred, for example, when the exhaust port in the cylinder head 115 has a smaller diameter than the exhaust gas passageway 20 of the main tube of the manifold 110, and it is desired to taper the diameter of the runner 106 (inner layer 122) between these two diameters. Ideally, the ceramic extruded inner layer 122 of the runner 106 has the same or substantially the same diameter as the main tube portion of the ceramic inner layer at the point where the two portions are joined.

[0060] It is desirable that the terminal edge of the ceramic inner layer 122 and the inlet port 133 are substantially round because this configuration results in a substantially circular inlet port 133 which permits the highest possible flux of exhaust gas per area, and also permits the greatest amount of compressive force to be uniformly exerted against the intermediately located sealing gasket 140 (described below).

[0061] In one embodiment, the entire ceramic inner layer (main tube portion and the depending extruded portion(s) 122 for the runner or runners 106) is slip cast as a single, integral structure wherein the interior passages of the main tube portion and the extruded portion(s) 122 have continuous fluid communication therebetween. See, e.g., FIG. 9 (discussed more fully below) showing a complete and integrally formed ceramic inner layer that has been slip cast into an appropriate configuration, which is then enclosed within opposing metal clamshell halves to provide the manifold.

[0062] A sealing gasket 140 is provided and compressed against the flange portion 132 adjacent the terminal end of the ceramic extruded inner layer 122. To achieve this construction, an O-ring gasket having an annular width equal to or somewhat less than that of the flange portion 132, and suitable thickness, can be laid down on the inner surface of the flange portion 132. Subsequently, the ceramic inner layer 122 can be inserted into position such that its terminal edge compresses the sealing gasket 140 thereby forming a seal between the ceramic inner layer 122 and the metallic outer layer 128 adjacent the runner inlet port 133. Preferably, the sealing gasket 140 is appropriately dimensioned and is made from a suitably flexible material such that when compressed as described in this paragraph, it is caused to expand into the gap 135 thereby shielding the terminal edge of the ceramic inner layer 122 from direct contact with the flange portion 132. In this manner, the fragile terminal edge of the ceramic inner layer 122 never contacts the metal flange portion 132, and the gasket material provided in the gap 135 protects the ceramic layer from damage due to unmatched thermal expansion through thermal cycling of the manifold. Also, a perimeter extending rib 142 can be provided that extends

inward from the inner surface of the metal extruded portion 131. The rib 142 extends toward the ceramic inner layer 122, but not far enough that it will contact that layer during cyclic expansion/compression which may be expected from thermal cycling. This rib 142 limits the expansion of the sealing gasket 140 away from the flange portion 132 on compression, thereby forcing the gasket 140 into greater and more intimate contact with the ceramic layer surface resulting in a more robust seal. The rib 142 can be formed integrally with and as part of the metal outer layer, or it can be separately provided and adhered at an appropriate location.

[0063] As seen in FIG. 8, the sealing gasket 140 is entirely shielded from direct contact with the cylinder head 115, as it is substantially completely contained in the space between the outer and ceramic inner layers 128 and 122. Insulation material, e.g. in the form of a composite insulation zone 124 or other insulating material or layer as herein described (e.g. similar to the ceramic insulating layers 32 described above), can be provided in the space between the outer and ceramic inner layers 128 and 122.

[0064] When installed, the runner 106 is coupled to the cylinder head 115 such that the exhaust port is aligned with the inlet port 133 of the runner 106. The runner 106 and cylinder head 115 can be mechanically coupled via suitable or conventional structure used for that purpose. Conventionally, a washer gasket 150 is provided and compressed in between the exhaust port and the inlet port 133 mating surfaces to prevent exhaust gas from leaking out from the exhaust port and around the runner 106 ("blow-by" leakage). However, as will be evident from the foregoing description and the associated figures, the washer gasket 150 is only responsible for preventing blow-by leakage of hot exhaust gases. The separate sealing gasket 140, which is provided substantially entirely within the metallic outer layer 128, is separately responsible for preventing hot exhaust gases from entering the annular space between the metallic outer and ceramic inner layers 128 and 122 of the runner 106. Thus, the sealing gasket 140 does not experience the abrasive sliding action that occurs between the inlet and exhaust port surfaces, and is not subject to being worn down thereby, even after a significant period of use and repeated thermal cycling.

[0065] In the embodiment illustrated in FIG. 8, a baffle washer 160 can be provided adjacent the facing surface of the flange portion 132 extending within the inlet port 133. The baffle washer 160 includes a flat circular portion that is provided or abutted against the outer or facing surface of the flange portion 132, and a cylindrical portion extending from the flat circular portion through the inlet port 133 of the runner 106, past the gap 135 and at least partially within the ceramic extruded inner layer 122. The baffle washer 160 is made from Inconel, less preferably stainless steel or other suitable high strength and oxidation resistant alloy. The baffle washer 160 is provided to shield the sealing gasket 140 compressed within the gap 135 from the turbulent flow of exhaust gas as it enters the inlet port 133. This may increase the useful life of the manifold by protecting the integrity of the gasket seal between the metal and ceramic layers located adjacent the inlet port 133. In addition, because the flat circular portion of the baffle washer, and not the flange portion 132 of the metal layer 128, contacts the washer gasket 150 and forms the seal therewith, the baffle washer 160 also may protect the integrity of the metallic

outer layer of the manifold against oxidation from the turbulent exhaust gases. This is an advantage because although the cylinder head **115** typically is equipped with a water cooling jacket, the runner **106** has no such cooling capability. The presently described structure minimizes contact between high temperature exhaust gases and the outer metal layer adjacent the inlet port **133**, which is particularly desirable if that layer is made of aluminum.

[0066] In an alternative construction, the washer gasket **150** that provides the seal between the flange portion **132** and the cylinder head **115** can be provided with a sleeve portion extending upward and through the inlet port **133** of the runner **106**, substantially lining the inlet port **133**. This construction also will prevent turbulent exhaust gases from impinging on the sealing gasket **140**.

[0067] The sealing gasket **140** is made from a suitably flexible material that is effective to maintain a gas-tight seal as described above. The sealing gasket **140** can be made, for example, from Grafoil® which is a well known compressible and resilient graphite material having a crystalline structure. In a preferred embodiment, when such a graphite material is used it is impregnated or formulated with additives to render it oxidation resistant. For example, Grafoil® can be impregnated with a substantially amorphous material selected from or containing (but not limited to) borate, silicate and/or phosphate glass of a transition metallic element, alkaline earth elements, alkali metals, Group III elements such as zinc, calcium, magnesium, and aluminum, and ceramic fillers such as TiB<sub>2</sub>, SiB<sub>6</sub> and TiC. Such materials can be chosen so as to obtain a protective layer separating the Grafoil and hot exhaust. Alternatively, the sealing gasket **140** also can be made out of ceramic fibers. In this case, one should select fiber compositions that will not undergo slow shrinkage or fracture during operating conditions. In this case it is desirable to compress the gasket seal **140** so that under any operating conditions, the movement between opposing surfaces of the gasket seal **140** will exhibit elastic deformation.

[0068] In a further alternative, the gasket seal **140** can be constructed having two parts or layers; for example with one layer that faces the hot exhaust gas being made out of ceramic fibers (which are substantially oxidation resistant), and another layer located distally from the exhaust gases (more proximate the insulating material provided between the ceramic inner layer **122** and the metal outer layer **128**) being made of a carbon or graphite based composition such as Grafoil®. Such a design combines the oxidation resistance of ceramic fibers with the excellent sealing capability of flexible graphite based materials like Grafoil®.

[0069] In addition to oxidation resistant additives, the gasket seal material also can include additives to enhance its thermal conductivity. Suitable conductivity enhancing additives include, e.g., Ag, BN, AlN, alumina, magnesia, SiC. By enhancing the thermal conductivity of the seal gasket **140**, the gasket **140** exhibits more efficient heat transfer properties enabling it to dissipate more heat. As a result, its temperature can be kept as low as possible to prevent or slow or minimize oxidation from the hot exhaust gases.

[0070] In the construction illustrated in FIG. 8, the metal-to-ceramic seal is provided by a sealing gasket **140** located in a position in between the respective layers adjacent the inlet port **133** for the associated runner **106**, yet it is

substantially entirely shielded from contact with the cylinder head **115** by the metallic outer layer **128** (flange portion **132**). Also in this design, the terminal end of the ceramic inner layer **122** is completely encased within the metallic outer layer **128** adjacent the inlet port **133** of the runner, and does not come into contact with the cylinder head. This design has multiple advantages. Because the ceramic layer is not exposed, the ceramic layer is protected from damage during handling and assembly of the manifold to the engine. Also, more precise compression of the gasket seal **140** can be achieved between the spaced terminal ends of the respective ceramic and metallic layers adjacent the inlet port **133** of the runner **106**.

[0071] Selection of gasket materials having suitable flexibility, compressibility, stiffness, etc., can be employed to achieve a precisely defined degree of compression or compressive force in the final installation, depending on manifold-specific design criteria such as the strength and/or brittleness of the particular ceramic composition used for the inner layer. Also, the gasket seal **140** can be made from a relatively soft material compared to the washer gasket **150** used to prevent blow-by leakage, which is an advantage because softer materials are more suitable for sealing against ceramic layers because they exert less stress on the ceramic while ensuring a gas-tight seal. Use of a soft gasket material would not be practical were the ceramic layer to be sealed directly against the cylinder head as in conventional constructions, because a soft gasket would wear very quickly due to manifold-to-cylinder head abrasion from thermal cycling because the head and the manifold will experience different rates of expansion and contraction. In a conventional manifold-to-cylinder head surface seal, the gasket is extremely hard and compresses only slightly, perhaps 10-15%. The sealing gasket **140** in the present embodiment preferably is compressed at least 20%, more preferably at least 30% between the concentric ceramic and metallic layers **122** and **128**.

[0072] As a result, manifold longevity is improved because the insulation layer (or composite insulation zone **124**) located between these layers will not be subjected to turbulent exhaust gases as a result of a degraded seal between the ceramic and metallic layers from manifold-to-cylinder head abrasion. Even if the washer gasket **150** were to become damaged or its integrity breached, this would not affect the integrity of the sealing gasket **140** which prevents turbulent exhaust gases from entering the annular insulation space between the ceramic and metallic layers. A further advantage of using the separate sealing gasket **140** is that the integrity of the resulting seal can be tested during the manufacturing process of the manifold itself, and no longer is left to the final engine assembly operation.

[0073] After the manifold has been assembled, in particular after the construction of the runner **106** as described above has been completed, it may be desirable for certain high temperature applications (e.g. exhaust gas temperatures about or greater than 1850° F.) to further seal the gap **135** between the ceramic and metallic layers via methods that may include brazing, dip coating or thermal spray coating.

[0074] Referring now to FIG. 9, a further embodiment is shown where O-ring gaskets **170** are provided at strategic locations in the annular space between the ceramic inner layer **22** and the metallic outer layer **28** of the main tube

portion of the exhaust manifold 10. In particular, a pair of O-ring gaskets 170 are provided in the main tube portion located on opposite sides of each runner 106. These O-ring gaskets 170 are or can be made from the same or similar materials as the sealing gasket 140 previously described, and are provided to prevent turbulent exhaust gases from traveling through the insulation space between the ceramic and metallic layers. The O-ring gaskets 170 are optional components, and are provided as a failsafe in the unlikely event the sealing gasket 140 described above should fail. In that event, the O-ring gaskets 170 will confine any exhaust gas that may be permitted to enter the insulation space to only that space adjacent the associated runner 106 where the gas entered; turbulent exhaust gases will not be permitted to flow through the remainder of the manifold insulation, and any loss of insulating capacity due to damage from these gases will be confined to only the runner 106 whose sealing gasket 140 might have failed.

[0075] An additional benefit of the O-ring gaskets 170 is that the spacing between the ceramic inner and metallic outer layers 22 and 28 can be very precisely controlled based on the thickness and compression of the O-ring gaskets, so that this spacing is no longer dependent on the insulation material (such as insulation zone 24 described in detail above) to provide the spacing. If the O-ring gaskets are to be provided solely for spacing purposes, then alternatively a ceramic rope 180 can be wrapped around the main tube of the ceramic inner layer 22 of the manifold 10 in a generally helical configuration as shown in FIG. 10 as a spacer. This configuration will not prevent the travel of exhaust gases in the insulation space or zone 24 because of the helical pathway of the rope 180, but it can be used as an effective spacer. The O-ring gaskets 170 or ceramic rope 180 are made from a compressible, compliant material, similar as that described for the sealing gasket 140 above. Therefore, these gaskets 170 or rope 180 also are able to absorb relative expansions/contractions between the concentric metallic outer and ceramic inner layers 28 and 22 of the manifold 10. Thus, when either the O-ring gaskets 170 or the ceramic rope 180 is/are used as spacers, these elements can take the place of a strain isolation layer 26 as described above. Alternatively, if a strain isolation layer 26 is to be used, then it is laid into the metallic clamshell halves for the outer layer 28 along the inner surface thereof prior to installing the inner layer 22 structure therein as shown in FIGS. 9-10 (discussed below).

[0076] When either the O-ring gaskets 170 or ceramic rope 180 is/are used as described above, the manifold can be assembled as follows. First, the ceramic inner layer 22/122 is slip cast as a unitary structure in the appropriate configuration for the desired manifold; i.e. having appropriately shaped and oriented main tube portion, depending extruded portions for runners, etc. Next, the O-ring gaskets 170 or ceramic rope 180 is/are provided around the main tube portion of the slip cast inner layer 22 in the appropriate configuration or at appropriate locations. The O-rings may be fashioned out of a ceramic rope that is cut to exact length so that when the rope is wrapped around the inner layer and the metallic clamshells are closed, resultant compression forces the two ends of the rope to join and effectively act as an O-ring. Alternatively, ceramic rope can be wrapped around tightly for multiple turns so that the contacting faces and sides are pressed against each other to form O-ring type seal. Grooves may be provided in the metallic shell to

facilitate positioning and constraining the ceramic rope or O-ring gaskets for sealing purposes.

[0077] Then, ceramic inner layer 22/122 is inserted into one of a pair of clamshell halves for the metallic outer layer 28/128 of the exhaust manifold. In the embodiments shown in FIGS. 9 and 10, the clamshell halves are made such that all the runners are provided in one clamshell half. The ceramic inner layer 22/122 having the O-ring gaskets 170 or ceramic rope 180 thereon is inserted into one of the clamshell halves so that the respective runner portions of the ceramic inner and metallic outer layers 122 and 128 are appropriately aligned. Once the appropriate alignment has been achieved, the ceramic layer 22/122 is seated in the respective clamshell half and then the second clamshell half is aligned and assembled to the first clamshell half, thereby enclosing the ceramic inner layer 22/122 therebetween. The O-ring gaskets 170 or ceramic rope 180 is/are designed so that they are compressed in the space between the ceramic layer 22/122 and the opposing clamshell halves of the metallic outer layer 28/128 when the clamshell halves are pressed together. Uniform compression across the entire manifold can be achieved by measuring the compressive force at periodic locations, e.g., using conventional load cells mounted to a fixture for compressing the clamshell halves together. Compressive load can be measured, for example, at four locations on the manifold, preferably corresponding to locations where O-ring gaskets 170 or the ceramic rope 180 is/are compressed between the clamshell halves and the ceramic inner layer 22/122. The clamshell halves can be selectively compressed together and fastened at selected locations such that the compressive force across the entire manifold as determined by the load cells is substantially uniform. It will be understood that adjustments can be made to the fastening means to ensure uniform compression. The clamshell halves can be secured together via any conventional or suitable fastening means, including welding, bolting or other suitable fasteners.

[0078] In this embodiment, it is preferred that a series of small access holes 190 be drilled through the wall of at least one of the clamshell halves so that insulating material can be provided or injected into the annular space between the respective ceramic and metallic layers once the manifold has been assembled. The insulating material can be in any suitable form that will permit injection through these access holes 190 that will substantially fill up the aforementioned annular space to thereby provide an appropriate insulating layer. Suitable insulating materials include ceramic fibers and filler materials, as well as glass or ceramic microspheres discussed above, or slurries of any of these or combinations of these. If a slurry is used, preferably the continuous phase is a highly volatile material such as alcohol, less preferably water. The slurry can be used to fill the annular space and then the volatile carrier baked or flashed off such that the flashed vapor can escape through the access holes 190 before they are sealed (described in next paragraph). If a separate strain isolation layer 26 is to be used in this embodiment, then it is laid down on the inner surface of each clamshell half prior to assembling around the ceramic layer 22 as shown in FIGS. 9-10, and the access holes 190 must be drilled completely through the outer layer 28 and the strain isolation layer 26 to permit injection of insulating material.

[0079] A metallic foil layer also can be provided in this embodiment. If a metallic foil layer is to be provided, it should be wrapped around the ceramic inner layer 22/122 prior to encasing that layer within the metallic outer layer 28/128, and preferably it is wrapped against the ceramic inner layer 22/122 prior to placing the O-rings 170 or ceramic rope 180 thereon. If the metallic foil is provided over the O-rings 170 or ceramic rope 180, then it will interfere with uniformly filling the space between the ceramic and metallic layers with insulation material through the access holes 190. Once this space has been filled, the access holes 190 can be closed as by welding a plug therein. Alternatively, the holes 180 can be threaded to accommodate threaded bolts or plugs (not shown).

[0080] Yet another method may be used to place ceramic insulation layers and metal foils between the space created by ceramic inner layer (22/122), metallic outer layer (28/128) and seals such as O-rings 170 or ceramic rope 180. Specifically, insulation components can be fabricated into modular fashion so that individual insulation modules can be inserted into and fitted within the annular sections defined radially between the ceramic inner and metallic outer layers, and longitudinally between adjacent O-rings 170 or turns of the ceramic rope 180. Since the contacting area of seals is much smaller than the contacting area of the modular ceramic insulation, the net effect on heat transfer due to slightly different thermal resistance of the seals will be very small. For example, two "C" sections or insulation modules may be placed in opposing relationship in the annular spaces defined for respective clamshell halves prior to assembly thereof, such that upon closing of the clamshell the opposed "C" shaped modules join to form a complete annular insulating layer. Similarly in cone shaped regions of the manifold (such as runner 106), a suitable cone shaped insulation package can be made for easy placement. It is understood that there are several methods to achieve the manifold architecture described in FIGS. 1-10 and the methods listed above are examples illustrating basic principles of assembly.

[0081] An exhaust manifold disclosed herein facilitates faster light off of the catalytic converter because the exhaust gas retains a greater proportion of its initial thermal energy on exiting the manifold and entry into the catalytic converter. Also, because heat loss to the exhaust manifold is significantly reduced, lighter metal such as aluminum can be used in the manifold provided operational stresses to the manifold are minimized as described above. The need for heat shields and for other high temperature resistant materials such as silicone-coated wires in the engine compartment also may be reduced or eliminated. Further, manifolds disclosed herein resist erosion and corrosion because the ceramic inner layer 22 effectively resists these effects.

EXAMPLES

[0082] A series of 4-inch diameter disc composites were prepared in order to simulate the composite structure of an exhaust manifold having a composite insulation zone as described herein, and to demonstrate the improved insulative properties of such a composite structure. In all, four disc composites were prepared, three samples incorporating a composite insulation zone and a fourth sample that did not have a composite insulation zone. All four samples included an inner ceramic layer made by pouring a fused silica slip composition on a Plaster of Paris mold. The slip composition

was product ICP-3 available from Industrial Ceramic Products, Marysville, Ohio. After the slip was dried each dried piece was fired in a ceramic kiln to cure the piece and form a finished inner ceramic layer. All four of the inner ceramic layers had a thickness of 0.265 inch.

[0083] Three separate composite insulation zones also were prepared. The first two consisted of alternating layers of aluminum foil and ceramic paper but were of different overall thickness (see table 1 for thicknesses). The third layer consisted of alternating layers of aluminum foil and thin layers of Zyalite™ ceramic paste from Vesuvius-McDaniel, Beaver Falls, Pa. Each of these composite layers was then laminated on one side to an inner ceramic layer, and on the other side to a layer of cold rolled steel to produce an overall composite structure of:

[0084] [ceramic inner layer][composite insulation zone][cold rolled steel layer]This composite structure was meant to simulate the composite structure of an exhaust manifold having the analogous layers as described hereinabove.

[0085] The fourth ceramic inner layer was laminated directly to a cold rolled steel layer to simulate the laminate construction of a conventional ceramic-lined exhaust manifold, and resulted the following composite construction:

[ceramic inner layer][cold rolled steel layer]

[0086] A test apparatus illustrated schematically in FIG. 7 was used to test the insulative properties of each of the four-above described sample composites. As seen in FIG. 7, one-inch thick Fiberfrax insulation boards 50 were used to create a vertically oriented enclosed channel 52. Each of the four disc composite test pieces (ref. num. 55 in FIG. 7) was suspended at the top of the channel 52 with the ceramic inner layer facing downward and exposed to the channel 52, and the steel layer facing upward away from the channel. An oxy-acetylene torch 54 was inserted through the Fiberfrax wall at the base of the channel 52 and ignited to heat the ceramic inner layer and simulate a hot exhaust gas condition. For each of the four samples the exposed surface temperatures of the inner ceramic layer and the steel layer were monitored by thermocouples, and the steady state values are reported below in table 1. For sample 2, data were collected for two ceramic inner layer surface temperatures which is the reason for the notation "#1" and "#2" for that sample.

TABLE 1

	Sample 1	Sample 2	Sample 3	Comparative
Ceramic inner layer thickness	0.265 inch	0.265 inch	0.265 inch	0.265 inch
Composite insulation zone thickness	0.105 inch	0.120 inch	0.120 inch	None
Cold rolled steel layer thickness	0.187 inch	0.187 inch	0.187 inch	0.187 inch
Insulation zone composition	Aluminum foil/ Ceramic paper	Aluminum foil/ Zyalite	Aluminum foil/ Zyalite	None
Ceramic inner layer surface T	1875° F.	#1: 1856° F. #2: 1882° F.	1906° F.	1851° F.

TABLE 1-continued

	Sample 1	Sample 2	Sample 3	Comparative
Steel surface T	340° F.	#1: 325° F. #2: 384° F.	212° F.	878° F.
Ambient Conditions	71° F.; 20% RH; Air speed = 0	71° F.; 20% RH; Air speed = 0	72° F.; 20% RH; Air speed = 8.9 MPH	71° F.; 20% RH; Air speed = 0

[0087] From the above it will be seen that a composite insulation zone including layers of highly reflective material such as aluminum foil greatly improves the insulative properties of the overall composite structure. Thus the outer metal surface or "skin" of the overall composite structure exhibits a greatly reduced surface temperature compared to a conventional construction where no composite insulation zone is provided.

[0088] Although the hereinabove described embodiments of the invention constitute the preferred embodiments, it should be understood that modifications can be made thereto without departing from the spirit and scope of the invention as set forth in the appended claims.

1. An exhaust manifold comprising a ceramic inner layer defining an exhaust gas passageway, a composite insulation zone disposed exterior to and adjacent said inner layer, a strain isolation layer disposed between said composite insulation zone and said outer structural layer, and an outer structural layer disposed exterior to said composite insulation zone, said composite insulation zone comprising at least one metallic foil layer.

2. An exhaust manifold according to claim 1, said composite insulation zone comprising a plurality of said metallic foil layers and at least one ceramic insulating layer disposed between adjacent ones of said metallic foil layers.

3. An exhaust manifold according to claim 1, said composite insulation zone comprising a plurality of said metallic foil layers and at least one substantially evacuated annular space disposed between adjacent ones of said metallic foil layers.

4. An exhaust manifold according to claim 1, said composite insulation zone comprising a plurality of said metallic foil layers and at least one microsphere layer disposed between adjacent ones of said metallic foil layers.

5. (canceled)

6. An exhaust manifold according to claim 1, said strain isolation layer being an intumescent mat.

7. An exhaust manifold according to claim 6, said intumescent mat comprising, by weight, 20-60 percent ceramic fibers, and 35-75 percent expandable material.

8. An exhaust manifold according to claim 7, said expandable material being vermiculite, perlite, or a mixture thereof.

9. An exhaust manifold according to claim 7, said intumescent mat further comprising an organic binder material effective to bind said ceramic fibers together to provide a coherent fibrous mat.

10. An exhaust manifold according to claim 6, said intumescent mat exhibiting the property of expanding on heating of said mat, and contracting on cooling thereof.

11. An exhaust manifold according to claim 6, said intumescent mat having a crossover temperature below which said mat exhibits the property of expanding on

heating and contracting on cooling, and above which said mat no longer exhibits the property of contracting on cooling.

12. An exhaust manifold according to claim 1, wherein said inner layer is 0.05-10 mm thick, said composite insulation zone is 1-40 mm thick and said outer layer is 1-25 mm thick.

13. An exhaust manifold according to claim 1, wherein said inner layer comprises a catalyst effective to convert at least a portion of CO and NO<sub>x</sub> in an exhaust gas flowing through said exhaust passageway to CO<sub>2</sub>, and N<sub>2</sub> and O<sub>2</sub> respectively.

14. An exhaust manifold according to claim 13, wherein said catalyst has the form ABO<sub>2</sub> and is selected from the group consisting of a) a perovskite catalyst, wherein A is a rare earth element and an alkaline earth element, and B is a transition metal element; and b) a fluorite catalyst, wherein A is a rare earth element and B is Ce or Zr.

15. An exhaust manifold according to claim 14, said catalyst being a perovskite metal oxide catalyst, wherein A is lanthanum and strontium, and B is selected from the group consisting of iron, cobalt, manganese, titanium, gallium, chromium, and nickel.

16. An exhaust manifold according to claim 14, said catalyst being a fluorite metal oxide catalyst, wherein A is a rare earth element, B is either Ce or Zr.

17. An exhaust manifold comprising a ceramic inner layer defining an exhaust gas passageway, an outer structural layer disposed exterior to said ceramic inner layer, and a strain isolation layer disposed intermediate said ceramic inner layer and said outer structural layer, said strain isolation layer comprising an intumescent mat.

18. An exhaust manifold according to claim 17, said intumescent mat comprising, by weight, 20-60 percent ceramic fibers, and 35-75 percent expandable material.

19. An intumescent mat according to claim 18, said expandable material being vermiculite, perlite, or a mixture thereof.

20. An exhaust manifold according to claim 18, said intumescent mat further comprising an organic binder material effective to bind said ceramic fibers together to provide a coherent fibrous mat.

21. An exhaust manifold according to claim 18, said intumescent mat exhibiting the property of expanding on heating of said mat, and contracting on cooling thereof.

22. An exhaust manifold according to claim 17, said intumescent mat having a crossover temperature below which said mat exhibits the property of expanding on heating and contracting on cooling, and above which said mat no longer exhibits the property of contracting on cooling.

23. An exhaust manifold according to claim 1, said manifold having a main tube portion and at least one runner extending from said main tube portion with an inlet port located at a terminal end of the runner, wherein the layers and the composite insulation zone described in claim 1 are provided in the main tube portion of the manifold,

the runner comprising a ceramic inner layer that is substantially encased within and spaced apart from a metallic outer layer thereof, said ceramic inner layer defining an exhaust gas passageway therein for conducting exhaust gas from said inlet port toward and into said main tube portion of said manifold,

wherein a sealing gasket is disposed and compressed between said ceramic inner and metallic outer layers of the runner at or adjacent the terminal end thereof, said sealing gasket being shielded by the metallic outer layer.

24. An exhaust manifold according to claim 23:

said metallic outer layer of said runner comprising a metallic extruded portion that extends from the main tube portion of the manifold, and an inwardly extending flange portion located at the terminal end of the metallic extruded portion,

said ceramic inner layer of said runner having an extruded configuration and extending from the main tube portion of the manifold, wherein the ceramic extruded layer approaches but does not contact the flange portion of the metallic outer layer of the runner, leaving a small gap between a terminal end of the ceramic extruded layer of the runner and the flange portion,

said sealing gasket being at least partially expanded in the gap between the terminal end of the ceramic extruded layer and the flange portion of the metallic outer layer, thereby shielding the terminal edge of the ceramic extruded layer from direct contact with said flange portion.

25. An exhaust manifold having a main tube portion and at least one runner extending from said main tube portion and having an inlet port located at a terminal end of the runner, the runner comprising a ceramic inner layer that is substantially encased within and spaced apart from a metallic outer layer, said ceramic inner layer defining an exhaust gas passageway therein for conducting exhaust gas from said inlet port toward and into said main tube portion of said manifold,

wherein a sealing gasket is disposed and compressed between said ceramic inner and metallic outer layers at or adjacent the terminal end of said runner, said sealing gasket being shielded by the metallic outer layer.

26. An exhaust manifold according to claim 25:

said metallic outer layer of said runner comprising a metallic extruded portion that extends from the main tube portion of the manifold, and an inwardly extending flange portion located at the terminal end of the metallic extruded portion,

said ceramic inner layer of said runner having an extruded configuration and extending from the main tube portion of the manifold, wherein the ceramic extruded layer approaches but does not contact the flange portion of the metallic outer layer of the runner, leaving a small gap between a terminal end of the ceramic extruded layer of the runner and the flange portion,

said sealing gasket being at least partially expanded in the gap between the terminal end of the ceramic extruded layer and the flange portion of the metallic outer layer, thereby shielding the terminal edge of the ceramic extruded layer from direct contact with said flange portion.

27. An exhaust manifold comprising a ceramic inner layer encased within and spaced apart from a metallic outer layer thus defining an annular space therebetween, said manifold having a main tube portion and at least one runner extending from said main tube portion,

wherein at least one O-ring gasket is provided and compressed in said annular space at a location in said main tube portion of said exhaust manifold.

28. An exhaust manifold according to claim 27, said ceramic inner layer comprising a ceramic main tube portion and a ceramic extruded portion that extends from and is in fluid communication with said ceramic main tube portion, said ceramic extruded portion defining an exhaust gas passageway therein for said at least one runner,

said metallic outer layer comprising a metallic main tube portion and a metallic extruded portion that extends from said metallic main tube portion, said metallic extruded portion substantially enclosing said ceramic extruded portion therein, thereby forming said at least one runner extending from said main tube portion of said manifold,

wherein said at least one O-ring gasket is located in said main tube portion adjacent said at least one runner.

29. An exhaust manifold according to claim 28, comprising a pair of O-ring gaskets located in said main tube portion adjacent opposite sides of said at least one runner.

\* \* \* \* \*