

(19)



Europäisches Patentamt
European Patent Office
Office européen des brevets



(11)

EP 0 902 505 A3

(12)

EUROPEAN PATENT APPLICATION

(88) Date of publication A3:
29.11.2000 Bulletin 2000/48

(51) Int. Cl.⁷: **H01R 13/523**

(43) Date of publication A2:
17.03.1999 Bulletin 1999/11

(21) Application number: **98117075.6**

(22) Date of filing: **09.09.1998**

(84) Designated Contracting States:
**AT BE CH CY DE DK ES FI FR GB GR IE IT LI LU
MC NL PT SE**
Designated Extension States:
AL LT LV MK RO SI

(72) Inventors:
• **Holmes, Robert
Skene, Aberdeenshire, AB32 6QN (GB)**
• **Meikle, Duncan James
Whitegairns, Aberdeen, AB23 8UH (GB)**

(30) Priority: **09.09.1997 GB 9719078
12.03.1998 GB 9805168**

(74) Representative:
**Pattullo, Norman et al
Murgitroyd and Company
373 Scotland Street
Glasgow G5 8QA (GB)**

(71) Applicant:
**Hydro-Bond Engineering Limited
Aberdeen, AB23 8EF (GB)**

(54) Sealed electrical and/or optical connector

(57) An electrical and/or optical connector is provided which is particularly, but not exclusively, for use underwater. The connector comprises male and female portions (100, 400, 10, 200, 300) wherein the male portion (100, 400) is provided with at least one probe (120) and the female portion (10, 200, 300) is provided with at least one socket. A moveable shuttle (12, 110) is provided on the male (100, 400) and/or female (10, 200, 300) portions to seal the probe (120) and/or sockets to

allow the connector to be mated and/or disconnected underwater. The portions may also be left disconnected underwater when "live". The portions typically contain an insulating fluid and are typically provided with pressure compensation means. There is also provided a housing for an electrical and/or optical connector which is particularly, but not exclusively, for use with a remotely operated vehicle.

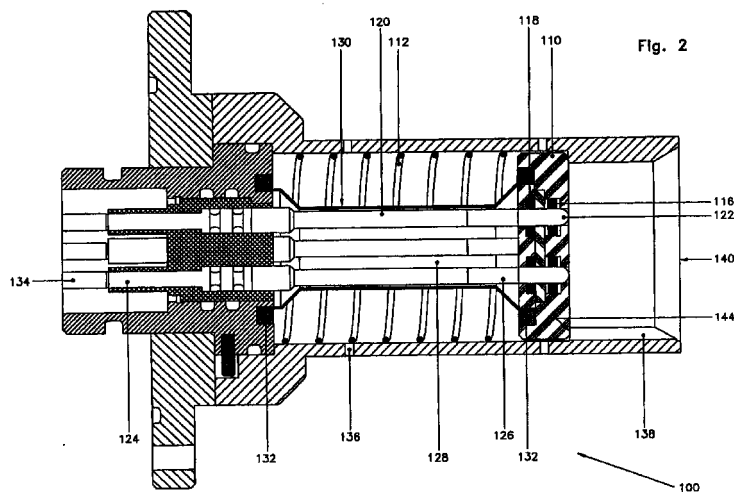

EP 0 902 505 A3



European Patent Office

EUROPEAN SEARCH REPORT

Application Number
EP 98 11 7075

DOCUMENTS CONSIDERED TO BE RELEVANT			
Category	Citation of document with indication, where appropriate, of relevant passages	Relevant to claim	CLASSIFICATION OF THE APPLICATION (Int.Cl.6)
X	EP 0 493 375 A (TRONIC ELECTRONIC SERVICES LIM) 1 July 1992 (1992-07-01)	1-22,28	H01R13/523
Y	* page 2, column 1, line 41 - page 3, column 3, line 12; figures 2,4 *	23-27, 29-31	
Y	GB 2 264 201 A (SWIFT 943 LTD) 18 August 1993 (1993-08-18) * page 7, line 5 - line 10; figure 1 *	23-27	
Y	EP 0 290 338 A (INST FRANCAIS DU PETROL ;GEOMECANIQUE (FR)) 9 November 1988 (1988-11-09) * page 3, column 4, line 38 - page 4, column 5, line 23; figures 1,2 *	29-31	
A	WO 96 22617 A (OCEAN DESIGN INC) 25 July 1996 (1996-07-25) * page 2, line 1 - page 3, line 10; figures 2,7 *	1-28	
The present search report has been drawn up for all claims			TECHNICAL FIELDS SEARCHED (Int.Cl.6)
			H01R
Place of search	Date of completion of the search	Examiner	
THE HAGUE	20 September 2000	Criqui, J-J	
CATEGORY OF CITED DOCUMENTS		T : theory or principle underlying the invention E : earlier patent document, but published on, or after the filing date D : document cited in the application L : document cited for other reasons	
X : particularly relevant if taken alone Y : particularly relevant if combined with another document of the same category A : technological background O : non-written disclosure P : intermediate document		& : member of the same patent family, corresponding document	

EPO FORM 1503 03.82 (P4/C01)

**ANNEX TO THE EUROPEAN SEARCH REPORT
ON EUROPEAN PATENT APPLICATION NO.**

EP 98 11 7075

This annex lists the patent family members relating to the patent documents cited in the above-mentioned European search report. The members are as contained in the European Patent Office EDP file on
The European Patent Office is in no way liable for these particulars which are merely given for the purpose of information.

20-09-2000

Patent document cited in search report	Publication date	Patent family member(s)	Publication date
EP 0493375 A	01-07-1992	EP 0251655 A	07-01-1988
		GB 2192316 A, B	06-01-1988
		NO 170959 C	03-11-1994
		US 4795359 A	03-01-1989
GB 2264201 A	18-08-1993	US 5334032 A	02-08-1994
EP 0290338 A	09-11-1988	FR 2615044 A	10-11-1988
		CA 1287671 A	13-08-1991
		CN 88102693 A, B	16-11-1988
		DE 3873598 A	17-09-1992
		DE 3873598 T	10-12-1992
		IN 170415 A	21-03-1992
		JP 1157077 A	20-06-1989
		JP 2678616 B	17-11-1997
		MX 169766 B	23-07-1993
		NO 881927 A, B,	07-11-1988
		US 4874328 A	17-10-1989
WO 9622617 A	25-07-1996	US 5645442 A	08-07-1997
		AU 4760096 A	07-08-1996
		BR 9607250 A	30-11-1999
		EP 0804818 A	05-11-1997
		NO 973348 A	19-09-1997

EPO FORM P0459

For more details about this annex : see Official Journal of the European Patent Office, No. 12/82