



- (51) **International Patent Classification:**
A01G 9/10 (2006.01)
- (21) **International Application Number:**
PCT/EP2017/064002
- (22) **International Filing Date:**
08 June 2017 (08.06.2017)
- (25) **Filing Language:** English
- (26) **Publication Language:** English
- (30) **Priority Data:**
PA 2016 00401 06 July 2016 (06.07.2016) DK
- (71) **Applicant:** ELLEPOT A/S [DK/DK]; Storstrømsvej 55,
6715 Esbjerg (DK).
- (72) **Inventor:** PEDERSEN, Bjarne, Brun; Degnegyden 3,
Orte, 5560 Aarup (DK).
- (74) **Agent:** LARSEN & BIRKEHOLM A/S; Banegårdsplad-
sen 1, 9. sal, 1570 Copenhagen V (DK).
- (81) **Designated States** (*unless otherwise indicated, for every
kind of national protection available*): AE, AG, AL, AM,
AO, AT, AU, AZ, BA, BB, BG, BH, BN, BR, BW, BY, BZ,
CA, CH, CL, CN, CO, CR, CU, CZ, DE, DJ, DK, DM, DO,
DZ, EC, EE, EG, ES, FI, GB, GD, GE, GH, GM, GT, HN,

HR, HU, ID, IL, IN, IR, IS, JP, KE, KG, KH, KN, KP, KR,
KW, KZ, LA, LC, LK, LR, LS, LU, LY, MA, MD, ME, MG,
MK, MN, MW, MX, MY, MZ, NA, NG, NI, NO, NZ, OM,
PA, PE, PG, PH, PL, PT, QA, RO, RS, RU, RW, SA, SC,
SD, SE, SG, SK, SL, SM, ST, SV, SY, TH, TJ, TM, TN, TR,
TT, TZ, UA, UG, US, UZ, VC, VN, ZA, ZM, ZW.

- (84) **Designated States** (*unless otherwise indicated, for every
kind of regional protection available*): ARIPO (BW, GH,
GM, KE, LR, LS, MW, MZ, NA, RW, SD, SL, ST, SZ, TZ,
UG, ZM, ZW), Eurasian (AM, AZ, BY, KG, KZ, RU, TJ,
TM), European (AL, AT, BE, BG, CH, CY, CZ, DE, DK,
EE, ES, FI, FR, GB, GR, HR, HU, IE, IS, IT, LT, LU, LV,
MC, MK, MT, NL, NO, PL, PT, RO, RS, SE, SI, SK, SM,
TR), OAPI (BF, BJ, CF, CG, CI, CM, GA, GN, GQ, GW,
KM, ML, MR, NE, SN, TD, TG).

Declarations under Rule 4.17:

— *of inventorship (Rule 4.17(iv))*

Published:

— *with international search report (Art. 21(3))*

(54) **Title:** USE OF AN AIR PERMEABLE COMPOSITE SHEET MATERIAL FOR PROPAGATION PLUGS FOR ORGANIC PRODUCTION

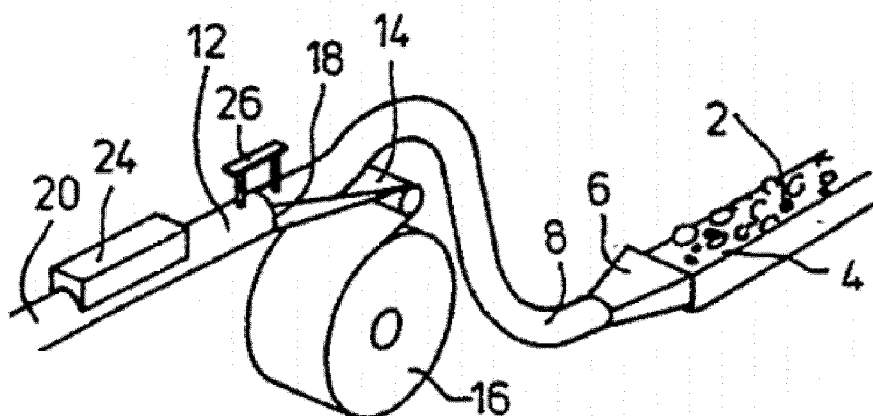

Fig. 1

(57) **Abstract:** The present invention relates to the production of propagation plugs, primarily small blocks of sphagnum (2) for the growing of cuttings and seed plants, and of the type consisting of a cylindrical block having an envelope of paper or a similar material and an associated filling of sphagnum (2) or a corresponding substrate material. The paper is an air permeable composite sheet material (14) comprising a) a biodegradable nonwoven sheet material; and b) a hot melt adhesive comprising at least 50% w/w of one or more biodegradable bioplastics. The hot melt adhesive is supplied to at least a part of a face of the biodegradable nonwoven sheet material (14).



Use of an air permeable composite sheet material for propagation plugs for organic production

Technical field of the invention

The present invention relates to the production of propagation plugs, primarily small
5 blocks of sphagnum for the growing of cuttings and seed plants, and of the type consisting of a cylindrical block having an envelope of paper or a similar material and an associated filling of sphagnum or a corresponding substrate material.

Background of the invention

Organic production does not allow for the use of chemically processed or derived
10 fertilizers commonly used in conventional agriculture. Some examples of these fertilizers are Urea, Ammonia, Ammonium Nitrate, Phosphoric Acid, Ammonium Phosphate compounds, and Calcium Nitrate. Materials that are allowed in organic production must be natural, organic materials or raw, mined minerals with few
15 exceptions. When producing propagation plugs having an envelope of paper and an associated filling of sphagnum, it is important that the paper retain its strength when wet, since the paper has a supporting function. This problem has been solved by coating the paper with a binder of petrochemical origin. During the production
20 process of propagation plugs, a continuous paper sheet is folded to a tube. The paper is fixed into a tube shape by gluing together parts of the opposing faces of the paper sheet. Sphagnum is then positioned within the formed tube by suction. The continuously formed tube is then cut into propagation plugs of suitable size.
The adhesive that has conventionally been used for the gluing step is a hot melt adhesive based on resins or waxes, mixed with fillers, pigments, and other
25 additives, such as stabilizers. Neither the conventional binder nor the hot melt adhesive can be used in a paper sheet in propagation plugs for organic production.

Summary of the invention

It is an object of the present invention to provide a paper sheet suitable for the
30 production of propagation plugs for organic production.

A first aspect relates to the use of an air permeable composite sheet material for producing continuous lengths of propagation plugs, the air permeable composite sheet material comprising:

- a biodegradable and air permeable nonwoven sheet material; and
- 5 - a hot melt adhesive comprising at least 50% w/w of one or more biodegradable bioplastics;

wherein the hot melt adhesive is supplied to at least a part of a face of the biodegradable and air permeable nonwoven sheet material.

- 10 As used in the specification and the appended claims, the singular forms "a", "an", and "the" include plural referents unless the context clearly dictates otherwise. Ranges may be expressed herein as from "about" or "approximately" one particular value and/or to "about" or "approximately" another particular value. When such a range is expressed, another embodiment includes from the one particular value
- 15 and/or to the other particular value. Similarly, when values are expressed as approximations, by use of the antecedent "about", it will be understood that the particular value forms another embodiment.

- 20 The term "continuous lengths of propagation plugs" refers to the production of growth medium, which is made in a continuous line as e.g. disclosed in WO9203914. The length of growth medium is thereafter cut into pieces of suitable size (height relative to the diameter), corresponding to the desired size of a propagation pot.

- 25 The term "biodegradable" as used herein describes the chemical dissolution of materials by bacteria or other biological means.

- 30 As used herein, the term "nonwoven sheet material" means a sheet material that has a structure of individual fibers or threads which are interlaid, but not in an identifiable repeating manner. Nonwoven sheet materials may be formed by a variety of processes such as, for example, meltblowing processes, spunbonding processes, coforming processes, and hydroentangling.

The fibers used for the air permeable nonwoven sheet material must be biodegradable, which can be natural or synthetic fibers, e.g. cellulosic fibers, protein fibers or synthetic polymer fibers. Natural fibers can comprise pulped or shredded cellulose fibers, such as wood pulp, shredded wood, shredded paper (tissue, newsprint and the like), straw, cotton fiber, composted vegetation, fibrous sphagnum moss, peat moss, shredded stalks including shredded corn stalks and shredded pine straw (including needles, twigs, cones and small branches). Shredded vegetation is preferably dry before shredding. Protein fibers can e.g. be hair or gelatin. Biodegradable synthetic fibers can comprise reconstituted cellulose fibers, such as rayon fibers, vinyl polymer fibers, such as fibrous polyvinyl alcohol and polyamide fibers.

The term "cellulosic fibers" as used herein describes fibers made from an organic compound derived primarily from plants such as trees.

The term "wood pulp fibers" as used herein describes a type of cellulosic fiber made from a lignocellulosic fibrous material prepared by chemically or mechanically separating cellulosic fiber from plants such as trees or cotton.

The term "regenerated/reconstituted cellulosic fibers" as used herein describes a type of cellulosic fiber made from wood pulp using a solvent fiber spinning process. The process involves dissolving wood pulp in a solvent, and spinning the resultant spinning solution into fibers.

In one or more embodiments, the biodegradable and air permeable nonwoven sheet material consist of spunlaced fibers without fiber binding materials. The term "spunlaced" as used herein refers to a structure of individual fibers or threads, which are physically entangled, without thermal bonding. Physical entanglement may be achieved using a water entanglement process, or alternatively, a needling process or a combination of both processes. The spunlaced fibers provide the strength to the nonwoven sheet without the need for a binder, also, and very importantly for the present use, when the nonwoven sheet is wet.

The inventor has found that another way of adding strength to the nonwoven sheet, especially when wet, is to treat the nonwoven sheet material with a binder formulation comprising or consisting of polysaccharide containing at least two carboxylic groups and a low molecular weight organic mono-, di- or poly-carboxylic acid in an aqueous carrier.

The carboxylated polysaccharide is one capable of forming a sol or a gel in the aqueous carrier. The carboxylated polysaccharide of the invention is preferably selected from carboxymethyl cellulose (CMC); polyuronic acid, such as galacturonic acid, for instance as comprised by pectin, including; polyuronic acid such as mannuronic acid and guluronic acid, for instance as comprised by alginic acid; oxidatively degraded polyuronic acid, for instance as disclosed in U.S. Pat. No. 6,903,209; sodium carboxymethyl starch (CMS), for instance as disclosed in U.S. Pat. No. 4,716,186; oxidized starch, for instance as disclosed in U.S. Pat. Nos. 5,959,101 and 6,518,419; carboxmethyl hemicellulose as such and in admixture with carboxymethyl cellulose, such as disclosed in U.S. 2005/0061204 A1; carboxymethyl lignocellulose, such as disclosed in U.S. Pat. No. 7,384,892. The carboxylated polysaccharide of the invention comprises its stoichiometric and non-stoichiometric sodium and potassium salts. Two or more carboxylated polysaccharides can be used in admixture.

The low molecular weight carboxylic acid is preferably an aliphatic carboxylic acid, most preferred a low molecular weight aliphatic di- or three-basic carboxylic acid. In particular, the carboxylic acid is one suitable for human consumption, such as acetic acid, mandelic acid, citric acid, tartaric acid, aspartic acid and glutamic acid. Particularly preferred are citric acid and tartaric acid. "Low molecular weight" in respect of the aliphatic organic acid of the invention signifies a molecular weight of less than 1000 Da, in particular of less than 500 Da, most preferred of less than 300 Da. Two or more carboxylic acids can be used in admixture.

The aqueous carrier is preferably water. The aqueous carrier may additionally comprise small amounts of inorganic salts such as sodium chloride, anti-oxidant such as ascorbic acid, metal ion scavenging agent such as EDTA, neutral or acidic surfactant, and the like.

The binder solution is preferably cured within the temperature range from 60° Celsius to 120° Celsius for 3 to 40 minutes. Still higher curing or drying temperatures require correspondingly shorter heating times, such as, for instance
5 from 1 minute or less at 200° Celsius. Alternatively, curing can be accomplished by heating the wet surface of the fibrous material for a very short time at a very high temperature, such as for a fraction of a second at a temperature of about 900° Celsius by irradiating the fibrous material with an infrared source. An important
10 aspect of the method of the invention is that curing is accomplished by the normal drying temperatures and processing times of the paper machine. The process of the invention does not require non-standard changes in procedures and parameters of the industrial-scale paper machine with which the process is carried out.

Curing temperature and time is influenced by the nature of the carboxylated
15 polysaccharide, the carboxylic acid, their weight proportions in the carrier, and the physical and chemical nature of the fibrous material. A person skilled in the art can determine adequate reaction conditions for a particular combination of carboxylated polysaccharide and carboxylic acid by carrying out a few simple experiments based on the present disclosure of the invention.

20 The binder formulation may comprise a weight ratio of low molecular carboxylic acid to carboxylated polysaccharide from 0.1 to 30 parts of acid per 100 parts of polysaccharide, more preferred from 5 to 15 parts of acid per 100 parts of polysaccharide. The combined concentration of carboxylated carbohydrate and
25 organic acid in the aqueous carrier can vary from 0.1% by weight to 30% by weight. For spray coating, a dry weight of from 1% to 5% is preferred.

In one or more embodiments, the biodegradable and air permeable nonwoven sheet material is coated with a binder formulation consisting of:

30 - a polysaccharide containing at least two carboxylic groups, selected from the group consisting of carboxymethyl cellulose; polyuronic acid; oxidatively degraded polyuronic acid; sodium carboxymethyl starch; oxidized starch; carboxmethyl hemicellulose; carboxymethyl lignocellulose; and mixtures thereof; or stoichiometric and non-stoichiometric sodium and potassium salts thereof;

- a low molecular weight organic mono-, di- or poly-carboxylic acid, selected from the group consisting of acetic acid, mandelic acid, citric acid, tartaric acid, aspartic acid, glutamic acid, formic acid, propionic acid, butanoic acid, pentanoic acid, oxalic acid, maleic acid, succinic acid, and glutaric acid; or a mixture of said organic mono-, di- or poly-carboxylic acids; and
- an aqueous carrier.

As used herein, "hot-melt adhesive" refers to a thermoplastic polymer or copolymer (e.g. polyhydroxybutyrate, polyhydroxyvalerate, or polyhydroxyalkanoate) that is heated to obtain a liquid of flowable viscosity, and, after application, cooled to obtain a solid. Generally, the molecular weight of the adhesive is tailored to provide good rheology as a melt and sufficient strength as a solid to resist shearing forces experienced in the application. The primary feature of hot-melt adhesives is the ability of the thermoplastic material (e.g. polyhydroxybutyrate, polyhydroxyvalerate, or polyhydroxyalkanoate) to flow above a certain temperature, and to provide a strong bond at the normal use temperature. Upon cooling, the material hardens, either through passing through the glass transition temperature or the crystallization temperature. This hardening lends physical integrity to the bond.

The hot melt may be coated on the entire face, or on both faces, of the biodegradable and air permeable nonwoven sheet material. Preferably, the hot melt is coated only on the one or two side edge areas (in the longitudinal direction) of the biodegradable and air permeable nonwoven sheet material, since only the joining edge area needs fixation.

In one or more embodiments, the hot melt adhesive comprises or consists of one or more biodegradable bioplastics selected from the group consisting of poly(lactic acid), aliphatic biopolyesters, polyhydroxybutyrate, polyhydroxyvalerate, polyhydroxyalkanoate, cellulose-based bioplastics, and mixtures thereof.

Especially, polyhydroxyalkanoates have shown also to function as soil conditioner. The term soil conditioner implies compounds, which favourably alter the physical and/or chemical properties of soil. The concept of using polymer materials as soil conditioners is not new. Natural polymers such as polyuronic acids, alginic acids,

agar, gum, pectin, starch, etc. have been successfully used in the past for soil conditioning. In one or more embodiments, the hot melt adhesive comprises or consists of polyhydroxyalkanoates.

- 5 The polyhydroxyalkanoates (PHAs) are synthesized by soil microbes for use as intracellular storage material. Hence, nonwoven sheet material made from the polymers are generally recognized by soil microbes as a food source.

10 In one or more embodiments, the hot melt adhesive comprises or consists of one or more biodegradable bioplastics selected from the group consisting of a poly(3-hydroxybutyrate) homopolymer, a poly(3-hydroxybutyrate-co-4-hydroxybutyrate), a poly(3-hydroxybutyrate-co-3-hydroxyvalerate), a poly(3-hydroxybutyrate-co-5-hydroxyvalerate), a poly(3-hydroxybutyrate-co-3-hydroxyhexanoate), and mixtures thereof.

15 Preferably, the hot melt adhesive comprises or consists of one or more biodegradable bioplastics of non-GMO (genetically modified organism) origin.

20 The hot melt adhesive comprises at least 50% w/w of one or more biodegradable bioplastics, such as at least 55% w/w, e.g. at least 60% w/w, such as at least 65% w/w, e.g. at least 70% w/w, such as at least 75% w/w, e.g. at least 80% w/w, such as at least 85% w/w, e.g. at least 90% w/w, such as at least 95% w/w, e.g. at least 99% w/w. Other components may be inorganic fillers or biodegradable organic fillers.

25 In one or more embodiments, hot melt adhesive comprises a reactive filler component, such as an aluminium compound, a magnesium compound, a calcium compound, a barium compound or a mixture thereof. Preferred are these compounds that react with acidic functional groups, for example carboxylic acid groups, carboxylic acid anhydride groups, hydroxyl groups, acidic amine groups, sulfonic acid groups, phosphonic acid groups, etc. The reactive filler may be, for example, in the form of oxides, hydroxides, silicates, etc., or a mixture thereof. Some exemplary compounds include, for example, aluminum oxide (Al₂O₃), aluminum hydroxide (Al(OH)₃), magnesium oxide (MgO), magnesium hydroxide

30

(Mg(OH)₂), calcium oxide (CaO), calcium hydroxide (Ca(OH)₂), barium oxide (BaO), barium hydroxide (Ba(OH)₂), aluminometasilicates, fluoroaluminosilicates and mixtures thereof. Aluminium compounds are particularly preferred, especially aluminium compounds that react with acidic functional groups.

- 5 Aluminium oxide, aluminium hydroxide, aluminium silicate, aluminium metasilicate and mixtures thereof are of particular note.

The reactive filler may be present in the hot-melt adhesive composition in any suitable amount. Of particular note is an amount of about 5% to about 50% by weight, or, of about 10% to about 45% by weight, or, of about 15% to about 40% by weight, based on the weight of the hot-melt adhesive composition. Use of reactive filler in the amounts noted above helps to bring characteristics of the adhesive composition closer to those of the biodegradable and air permeable nonwoven sheet material in terms of thermal expansion, deformation, stiffness, etc.

10 The amounts noted above also lead to less shrinkage due to consolidation thus reducing internal stress in the adhesive, to less stress concentration in a joint formed with the adhesive, to better fatigue resistance in the joint, and to decreased sensitivity of the adhesive composition to moisture.

20 A second aspect relates to a method of manufacturing continuous lengths of propagation plugs comprising:

- suctioning sphagnum or a corresponding substrate material through a pipe into a suction chamber for deposition and compaction within the suction chamber by suction applied through a perforated tube in the suction chamber;
- forming a plug of the compacted sphagnum or a corresponding substrate material in an outlet conduit of the suction chamber as part of compacting the sphagnum or a corresponding substrate material within the suction chamber;
- introducing an air permeable composite sheet material through an aperture in the pipe; wherein the air permeable composite sheet material comprises:
 - a biodegradable and air permeable nonwoven sheet material; and
 - 30 - a hot melt adhesive comprising at least 50% w/w of one or more biodegradable bioplastics;

wherein the hot melt adhesive is supplied to at least a part of a face of the biodegradable and air permeable nonwoven sheet material;

- forming a lining hose from the air permeable composite sheet material in an end portion of the pipe adjacent the suction chamber; and
- joining the edge area of the lining hose by conveying the lining hose containing the compacted sphagnum or a corresponding substrate material through a heating station, such that thereafter the air permeable nonwoven sheet material is stabilized in its hose shape for further advancing inside the pipe.

In one or more embodiments, the method further comprises the step of conveying the lining hose containing the compacted sphagnum or a corresponding substrate material from the suction chamber by gripping the lining hose and moving the gripped lining hose.

A third aspect relates to an air permeable composite sheet material supplied on a reel, the sheet material being of the type used for producing continuous lengths of propagation plugs; the composite sheet material comprising:

- a biodegradable and air permeable nonwoven sheet material; and
- a hot melt adhesive comprising at least 50% w/w of one or more biodegradable bioplastics;

wherein the hot melt adhesive is supplied to at least a part of a face of the biodegradable and air permeable nonwoven sheet material.

It should be noted that embodiments and features described in the context of one of the aspects of the present invention also apply to the other aspects of the invention.

25 **Brief description of the figures**

Figure 1 shows a perspective view of a system performing the method in accordance with various embodiments of the invention.

Detailed description of the invention

30 Figure 1 shows a perspective view of a system performing the method in accordance with various embodiments of the invention. In the right hand side of the figure is shown an amount of sphagnum or a corresponding substrate material 2

supplied on a conveyor belt 4 forwardly conveying towards the end of a suction funnel 6. The suction funnel 6 projects into a first part 8 of a conveyor pipe. It is not decisive how the sphagnum is supplied to the first part 8 of the conveyor pipe, as long as it is a continuous delivery. The first part 8 of the conveyor pipe extends into a folding zone 12, in which an air permeable composite sheet material 14 according to the present invention is supplied from a storage reel 16 and successively wrapped about the first part 8 of the conveyor pipe and continues into a second part 20 of the conveyor pipe. The air permeable composite sheet material 14 continues into the second part 20 of the conveyor pipe through a narrow annular slot 18 (holding means 26 is arranged for fixing of the pipe parts in this area) to form an inner lining hose in the second part 20 of the conveyor pipe. The air permeable composite sheet material 14 comprises a hot melt adhesive supplied to at least a part of a face of an air permeable biodegradable nonwoven sheet material. The hot melt is activated in a heating station 24, whereby the air permeable composite sheet material 14 is stabilized in its hose shape for further advancing inside the second part 20 of the conveyor pipe.

References

- 2 Sphagnum or a corresponding substrate material
- 4 Conveyor belt
- 5 6 Suction funnel
- 8 First part of a conveyor pipe
- 12 Folding zone
- 14 Air permeable composite sheet material
- 16 Storage reel
- 10 18 Annular slot
- 20 Second part of a conveyor pipe
- 24 Heating station
- 26 Holding means

Claims

1. Use of an air permeable composite sheet material for producing continuous lengths of propagation plugs, the air permeable composite sheet material comprising:
- 5 - a biodegradable and air permeable nonwoven sheet material; and
- a hot melt adhesive comprising at least 50% w/w of one or more biodegradable bioplastics;
- wherein the hot melt adhesive is supplied to at least a part of a face of the biodegradable and air permeable nonwoven sheet material.
- 10
2. Use according to claim 1, wherein the biodegradable and air permeable nonwoven sheet material consist of spunlaced fibers without fiber binding materials.
3. Use according to claim 1, wherein the biodegradable and air permeable nonwoven sheet material is coated with a binder formulation consisting of:
- 15 - a polysaccharide containing at least two carboxylic groups, selected from the group consisting of carboxymethyl cellulose; polyuronic acid; oxidatively degraded polyuronic acid; sodium carboxymethyl starch; oxidized starch; carboxmethyl hemicellulose; carboxymethyl lignocellulose; and mixtures thereof; or stoichiometric and non-stoichiometric sodium and potassium salts thereof;
- 20 - a low molecular weight organic mono-, di- or poly-carboxylic acid, selected from the group consisting of acetic acid, mandelic acid, citric acid, tartaric acid, aspartic acid, glutamic acid, formic acid, propionic acid, butanoic acid, pentanoic acid, oxalic acid, maleic acid, succinic acid, and glutaric acid; or a mixture of said organic mono-
- 25 , di- or poly-carboxylic acids; and
- an aqueous carrier.
4. Use according to any one of the claims 1-3, wherein the hot melt adhesive comprises one or more biodegradable bioplastics selected from the group consisting of poly(lactic acid), aliphatic biopolyesters, polyhydroxybutyrate,
- 30 polyhydroxyvalerate, polyhydroxyalkanoate, cellulose-based bioplastics, and mixtures thereof.

5. Use according to any one of the claims 1-3, wherein the hot melt adhesive comprises one or more biodegradable bioplastics selected from the group consisting of a poly(3-hydroxybutyrate) homopolymer, a poly(3-hydroxybutyrate-co-4-hydroxybutyrate), a poly(3-hydroxybutyrate-co-3-hydroxyvalerate), a poly(3-hydroxybutyrate-co-5-hydroxyvalerate), a poly(3-hydroxybutyrate-co-3-hydroxyhexanoate), and mixtures thereof.
6. Use according to any one of the claims 1-5, wherein the hot melt adhesive comprises a reactive filler component, selected from the group consisting of:
aluminum oxide, aluminum hydroxide, magnesium oxide, magnesium hydroxide,
calcium oxide, calcium hydroxide, barium oxide, barium hydroxide,
aluminometasilicates, fluoroaluminosilicates, and mixtures thereof.
7. Use according to any one of the claims 1-6, wherein the air permeable composite sheet material is supplied on a reel.
8. A method of manufacturing continuous lengths of propagation plugs comprising:
- suctioning sphagnum or a corresponding substrate material through a pipe into a suction chamber for deposition and compaction within the suction chamber by suction applied through a perforated tube in the suction chamber;
- forming a plug of the compacted sphagnum or a corresponding substrate material in an outlet conduit of the suction chamber as part of compacting the sphagnum or a corresponding substrate material within the suction chamber;
- introducing an air permeable composite sheet material through an aperture in the pipe; wherein the air permeable composite sheet material comprises:
- a biodegradable and air permeable nonwoven sheet material; and
- a hot melt adhesive comprising at least 50% w/w of one or more biodegradable bioplastics;
wherein the hot melt adhesive is supplied to at least a part of a face of the biodegradable and air permeable nonwoven sheet material;
- forming a lining hose from the air permeable composite sheet material in an end portion of the pipe adjacent the suction chamber; and
- joining the edge area of the lining hose by conveying the lining hose containing the compacted sphagnum or a corresponding substrate material through a heating

station, such that thereafter the air permeable nonwoven sheet material is stabilized in its hose shape for further advancing inside the pipe.

9. A method according to claim 8, wherein the biodegradable and air permeable
5 nonwoven sheet material consist of spunlaced fibers without fiber binding materials.

10. A method according to claim 8, wherein the biodegradable and air permeable nonwoven sheet material is coated with a binder formulation consisting of:

- a polysaccharide containing at least two carboxylic groups, selected from the
10 group consisting of carboxymethyl cellulose; polyuronic acid; oxidatively degraded polyuronic acid; sodium carboxymethyl starch; oxidized starch; carboxmethyl hemicellulose; carboxymethyl lignocellulose; and mixtures thereof; or stoichiometric and non-stoichiometric sodium and potassium salts thereof;
- a low molecular weight organic mono-, di- or poly-carboxylic acid, selected from
15 the group consisting of acetic acid, mandelic acid, citric acid, tartaric acid, aspartic acid, glutamic acid, formic acid, propionic acid, butanoic acid, pentanoic acid, oxalic acid, maleic acid, succinic acid, and glutaric acid; or a mixture of said organic mono-, di- or poly-carboxylic acids; and
- an aqueous carrier.

20 11. A method according to any one of the claims 8-10, wherein the hot melt adhesive comprises one or more biodegradable bioplastics selected from the group consisting of poly(lactic acid), aliphatic biopolyesters, polyhydroxybutyrate, polyhydroxyvalerate, polyhydroxyalkanoate, cellulose-based bioplastics, and
25 mixtures thereof.

12. A method according to any one of the claims 8-10, wherein the hot melt adhesive comprises one or more biodegradable bioplastics selected from the group consisting of a poly(3-hydroxybutyrate) homopolymer, a poly(3- hydroxybutyrate-co-
30 4-hydroxybutyrate), a poly(3-hydroxybutyrate-co-3- hydroxyvalerate), a poly(3- hydroxybutyrate-co-5-hydroxyvalerate), a poly(3-hydroxybutyrate-co-3- hydroxyhexanoate), and mixtures thereof.

13. A method according to any one of the claims 8-12, wherein the hot melt adhesive comprises a reactive filler component, selected from the group consisting of: aluminum oxide, aluminum hydroxide, magnesium oxide, magnesium hydroxide, calcium oxide, calcium hydroxide, barium oxide, barium hydroxide,
5 aluminometasilicates, fluoroaluminosilicates, and mixtures thereof.
14. A method according to any one of the claims 8-13, wherein the air permeable composite sheet material is supplied on a reel.
- 10 15. An air permeable composite sheet material supplied on a reel, the sheet material being of the type used for producing continuous lengths of propagation plugs; the air permeable composite sheet material comprising:
- a biodegradable and air permeable nonwoven sheet material; and
- a hot melt adhesive comprising at least 50% w/w of one or more biodegradable
15 bioplastics;
wherein the hot melt adhesive is supplied to at least a part of a face of the biodegradable nonwoven sheet material.
16. An air permeable composite sheet material supplied on a reel according to claim
20 15, wherein the biodegradable and air permeable nonwoven sheet material consist of spunlaced fibers without fiber binding materials.
17. An air permeable composite sheet material supplied on a reel according to claim
25 15, wherein the biodegradable and air permeable nonwoven sheet material is coated with a binder formulation consisting of:
- a polysaccharide containing at least two carboxylic groups, selected from the group consisting of carboxymethyl cellulose; polyuronic acid; oxidatively degraded polyuronic acid; sodium carboxymethyl starch; oxidized starch; carboxymethyl hemicellulose; carboxymethyl lignocellulose; and mixtures thereof; or stoichiometric
30 and non-stoichiometric sodium and potassium salts thereof;
- a low molecular weight organic mono-, di- or poly-carboxylic acid, selected from the group consisting of acetic acid, mandelic acid, citric acid, tartaric acid, aspartic acid, glutamic acid, formic acid, propionic acid, butanoic acid, pentanoic acid, oxalic

acid, maleic acid, succinic acid, and glutaric acid; or a mixture of said organic mono-, di- or poly-carboxylic acids; and
- an aqueous carrier.

- 5 18. An air permeable composite sheet material supplied on a reel according to any one of the claims 15-17, wherein the hot melt adhesive comprises a reactive filler component, selected from the group consisting of: aluminum oxide, aluminum hydroxide, magnesium oxide, magnesium hydroxide, calcium oxide, calcium hydroxide, barium oxide, barium hydroxide, aluminometasilicates,
10 fluoroaluminosilicates, and mixtures thereof.

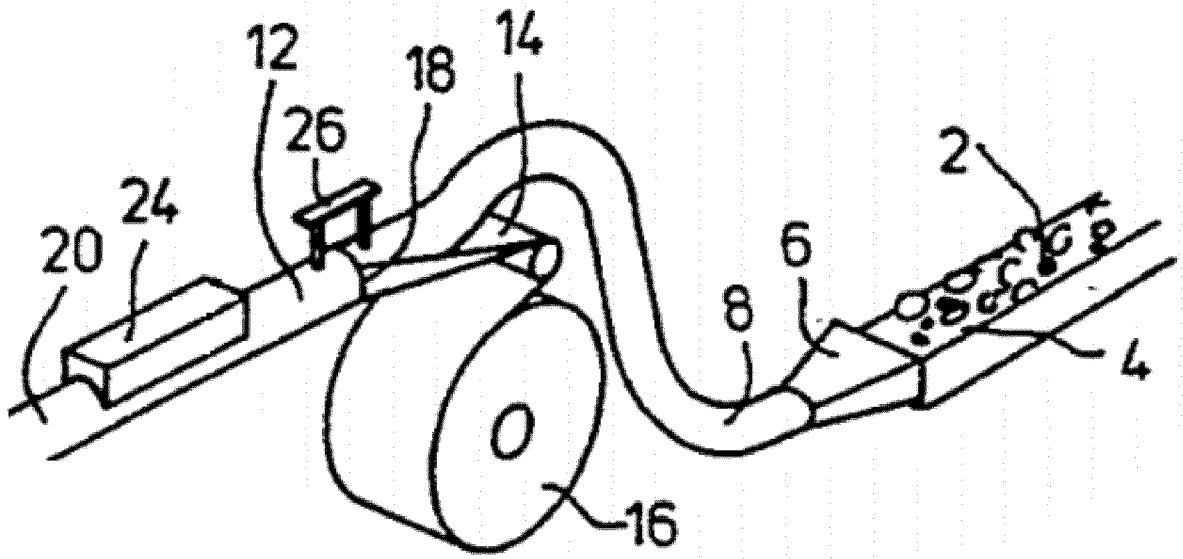

Fig. 1

INTERNATIONAL SEARCH REPORT

International application No
PCT/EP2017/064002

A. CLASSIFICATION OF SUBJECT MATTER
INV. A01G9/10
ADD.
According to International Patent Classification (IPC) or to both national classification and IPC

B. FIELDS SEARCHED
Minimum documentation searched (classification system followed by classification symbols)
A01G

Documentation searched other than minimum documentation to the extent that such documents are included in the fields searched

Electronic data base consulted during the international search (name of data base and, where practicable, search terms used)
EPO-Internal

C. DOCUMENTS CONSIDERED TO BE RELEVANT

| Category* | Citation of document, with indication, where appropriate, of the relevant passages | Relevant to claim No. |
|-----------|--|------------------------|
| X | US 5 595 020 A (ITO SUMIO [JP] ET AL) 21 January 1997 (1997-01-21) | 1,15 |
| Y | examples 2,3 | 7,8,14 |
| A | | 2-6, 9-13, 16-18 |
| Y | ----- US 5 382 403 A (ELLEGAARD OYVIND [DK]) 17 January 1995 (1995-01-17) | 7,8,14 |
| A | column 2, line 23 - column 4, line 8; claims 9-12; figures & WO 92/03914 A1 19 March 1992 (1992-03-19) cited in the application ----- -/-- | 1-6, 9-13, 15-18 |

Further documents are listed in the continuation of Box C.

See patent family annex.

* Special categories of cited documents :

- "A" document defining the general state of the art which is not considered to be of particular relevance
- "E" earlier application or patent but published on or after the international filing date
- "L" document which may throw doubts on priority claim(s) or which is cited to establish the publication date of another citation or other special reason (as specified)
- "O" document referring to an oral disclosure, use, exhibition or other means
- "P" document published prior to the international filing date but later than the priority date claimed

- "T" later document published after the international filing date or priority date and not in conflict with the application but cited to understand the principle or theory underlying the invention
- "X" document of particular relevance; the claimed invention cannot be considered novel or cannot be considered to involve an inventive step when the document is taken alone
- "Y" document of particular relevance; the claimed invention cannot be considered to involve an inventive step when the document is combined with one or more other such documents, such combination being obvious to a person skilled in the art
- "&" document member of the same patent family

| | |
|---|--|
| Date of the actual completion of the international search 23 August 2017 | Date of mailing of the international search report 04/09/2017 |
|---|--|

| | |
|--|---|
| Name and mailing address of the ISA/ European Patent Office, P.B. 5818 Patentlaan 2 NL - 2280 HV Rijswijk Tel. (+31-70) 340-2040, Fax: (+31-70) 340-3016 | Authorized officer Merckx, Alain |
|--|---|

INTERNATIONAL SEARCH REPORT

International application No
PCT/EP2017/064002

| C(Continuation). DOCUMENTS CONSIDERED TO BE RELEVANT | | |
|--|--|-----------------------|
| Category* | Citation of document, with indication, where appropriate, of the relevant passages | Relevant to claim No. |
| A | WO 2013/174386 A1 (SUNGROW AS [DK]) 28 November 2013 (2013-11-28) page 8, line 14 - line 28; figures ----- | 1-18 |
| A | US 3 788 003 A (CREIGHTON S ET AL) 29 January 1974 (1974-01-29) column 6, line 38 - column 7, line 15; claims; figures 1,2,7 ----- | 1,8,15 |
| A | US 4 231 186 A (RUUSKA MAUNO) 4 November 1980 (1980-11-04) column 2, line 30 - column 3, line 27; claims; figures ----- | 1,15 |
| A | GB 2 130 064 A (POTMA OY) 31 May 1984 (1984-05-31) the whole document ----- | 1,15 |

INTERNATIONAL SEARCH REPORT

Information on patent family members

International application No

PCT/EP2017/064002

| Patent document cited in search report | Publication date | Patent family member(s) | Publication date |
|--|------------------|-------------------------|-----------------------------|
| US 5595020 | A | 21-01-1997 | JP 2747879 B2 06-05-1998 |
| | | | JP H07123869 A 16-05-1995 |
| | | | TW 274506 B 21-04-1996 |
| | | | US 5595020 A 21-01-1997 |
| ----- | | | |
| US 5382403 | A | 17-01-1995 | AT 140361 T 15-08-1996 |
| | | | AU 665518 B2 11-01-1996 |
| | | | BR 9106808 A 06-07-1993 |
| | | | CA 2089655 A1 04-03-1992 |
| | | | DE 69120953 D1 22-08-1996 |
| | | | DE 69120953 T2 20-02-1997 |
| | | | DK 0548167 T3 25-11-1996 |
| | | | EP 0548167 A1 30-06-1993 |
| | | | ES 2092577 T3 01-12-1996 |
| | | | FI 930931 A 03-03-1993 |
| | | | GR 3021401 T3 31-01-1997 |
| | | | HU 215530 B 28-01-1999 |
| | | | JP 2763959 B2 11-06-1998 |
| | | | JP H06500694 A 27-01-1994 |
| | | | NO 930659 A 24-02-1993 |
| | | | PL 168978 B1 31-05-1996 |
| | | | RU 2090055 C1 20-09-1997 |
| | | | US 5382403 A 17-01-1995 |
| | | | WO 9203914 A1 19-03-1992 |
| | | | ----- |
| WO 2013174386 | A1 | 28-11-2013 | AU 2013265732 A1 15-01-2015 |
| | | | CA 2873937 A1 28-11-2013 |
| | | | CN 104363753 A 18-02-2015 |
| | | | DK 2852276 T3 26-09-2016 |
| | | | EP 2852276 A1 01-04-2015 |
| | | | ES 2594809 T3 22-12-2016 |
| | | | LT 2852276 T 25-11-2016 |
| | | | PL 2852276 T3 30-12-2016 |
| | | | PT 2852276 T 14-10-2016 |
| | | | SI 2852276 T1 31-01-2017 |
| | | | US 2015135589 A1 21-05-2015 |
| | | | WO 2013174386 A1 28-11-2013 |
| | | | ----- |
| US 3788003 | A | 29-01-1974 | NONE |
| ----- | | | |
| US 4231186 | A | 04-11-1980 | AR 214325 A1 31-05-1979 |
| | | | AT 352461 B 25-09-1979 |
| | | | AU 513561 B2 11-12-1980 |
| | | | BG 35591 A3 15-05-1984 |
| | | | BR 7703691 A 21-03-1978 |
| | | | CA 1061563 A 04-09-1979 |
| | | | CS 202573 B2 30-01-1981 |
| | | | DE 2725220 A1 22-12-1977 |
| | | | DK 252677 A 10-12-1977 |
| | | | ES 459546 A1 16-11-1978 |
| | | | FI 761655 A 10-12-1977 |
| | | | FR 2354044 A1 06-01-1978 |
| | | | GB 1553484 A 26-09-1979 |
| | | | GR 61247 B 12-10-1978 |
| | | | HU 174338 B 28-12-1979 |
| | | | IT 1083137 B 21-05-1985 |
| | | | JP S5922489 B2 26-05-1984 |
| | | | JP S52150249 A 13-12-1977 |

INTERNATIONAL SEARCH REPORT

Information on patent family members

International application No

PCT/EP2017/064002

| Patent document cited in search report | Publication date | Patent family member(s) | Publication date |
|--|------------------|-------------------------|------------------|
| | | NL 7706068 A | 13-12-1977 |
| | | SE 433694 B | 12-06-1984 |
| | | SU 639407 A3 | 25-12-1978 |
| | | US 4231186 A | 04-11-1980 |
| | | YU 136577 A | 31-05-1982 |
| ----- | | | |
| GB 2130064 | A | 31-05-1984 | |
| | | AT 384522 B | 25-11-1987 |
| | | AU 556704 B2 | 13-11-1986 |
| | | BR 8306251 A | 19-06-1984 |
| | | CA 1232455 A | 09-02-1988 |
| | | CS 8308451 A2 | 17-09-1985 |
| | | DE 3338856 A1 | 17-05-1984 |
| | | DK 521383 A | 17-05-1984 |
| | | ES 275579 U | 01-08-1985 |
| | | FI 71650 B | 31-10-1986 |
| | | FR 2535936 A1 | 18-05-1984 |
| | | GB 2130064 A | 31-05-1984 |
| | | GR 79033 B | 02-10-1984 |
| | | IN 162864 B | 16-07-1988 |
| | | IT 1162982 B | 01-04-1987 |
| | | JP S59109120 A | 23-06-1984 |
| | | NO 834175 A | 18-05-1984 |
| | | SE 458816 B | 16-05-1989 |
| | | SU 1360571 A3 | 15-12-1987 |
| | | US 4578899 A | 01-04-1986 |
| | | YU 223983 A | 30-04-1988 |
| ----- | | | |