



US007150027B2

(12) **United States Patent**
d'Alayer de Costemore d'Arc

(10) **Patent No.:** **US 7,150,027 B2**
(45) **Date of Patent:** **Dec. 12, 2006**

(54) **TRANSFER DEVICE FOR INFORMATION CARRIERS**

(75) Inventor: **Stéphane Marie André d'Alayer de Costemore d'Arc**, Genappe (BE)

(73) Assignee: **Staar S.A.**, Brussels (BE)

(*) Notice: Subject to any disclaimer, the term of this patent is extended or adjusted under 35 U.S.C. 154(b) by 179 days.

(21) Appl. No.: **10/519,658**

(22) PCT Filed: **Dec. 10, 2003**

(86) PCT No.: **PCT/BE03/00215**

§ 371 (c)(1),
(2), (4) Date: **Dec. 23, 2004**

(87) PCT Pub. No.: **WO2004/055805**

PCT Pub. Date: **Jul. 1, 2004**

(65) **Prior Publication Data**

US 2005/0249102 A1 Nov. 10, 2005

(30) **Foreign Application Priority Data**

Dec. 18, 2002 (BE) 2002/0736

(51) **Int. Cl.**
G11B 17/04 (2006.01)

(52) **U.S. Cl.** **720/656**

(58) **Field of Classification Search** **720/656,**
720/619-625, 645

See application file for complete search history.

(56) **References Cited**

U.S. PATENT DOCUMENTS

5,764,612 A *	6/1998	Tanaka et al.	720/623
5,867,338 A	2/1999	Ohira	
5,914,929 A *	6/1999	Kato et al.	720/656
6,377,538 B1	4/2002	D'Alayer	
2003/0103434 A1 *	6/2003	Kuo	369/77.1

FOREIGN PATENT DOCUMENTS

EP	1087388 A1	3/2001
JP	2002170305 A *	6/2002
JP	2002358710 A *	12/2002

* cited by examiner

Primary Examiner—William J Klimowicz
(74) *Attorney, Agent, or Firm*—Leydig, Voit & Mayer, Ltd.

(57) **ABSTRACT**

A transfer device is provided that ensures transfer of information carriers of different dimensions due to a single loading device including a detection mechanism means (32) associated with linking elements (40). Upon the insertion of an information carrier, the linking elements (40) cooperates with a projection (50A, 50B) set in relation with the size of the inserted information carrier. The projection is supported by a slider (52) that actuates clamping and driving mechanisms to ensure the setting of the inserted information carrier in its operative position. Thus, the synchronization between the clamping and driving mechanisms is made in relation with the size of said carrier.

9 Claims, 4 Drawing Sheets

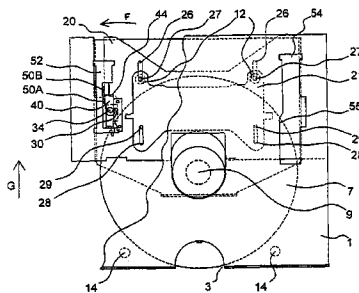
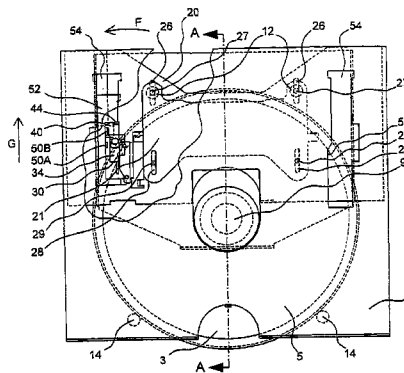

FIG. 1

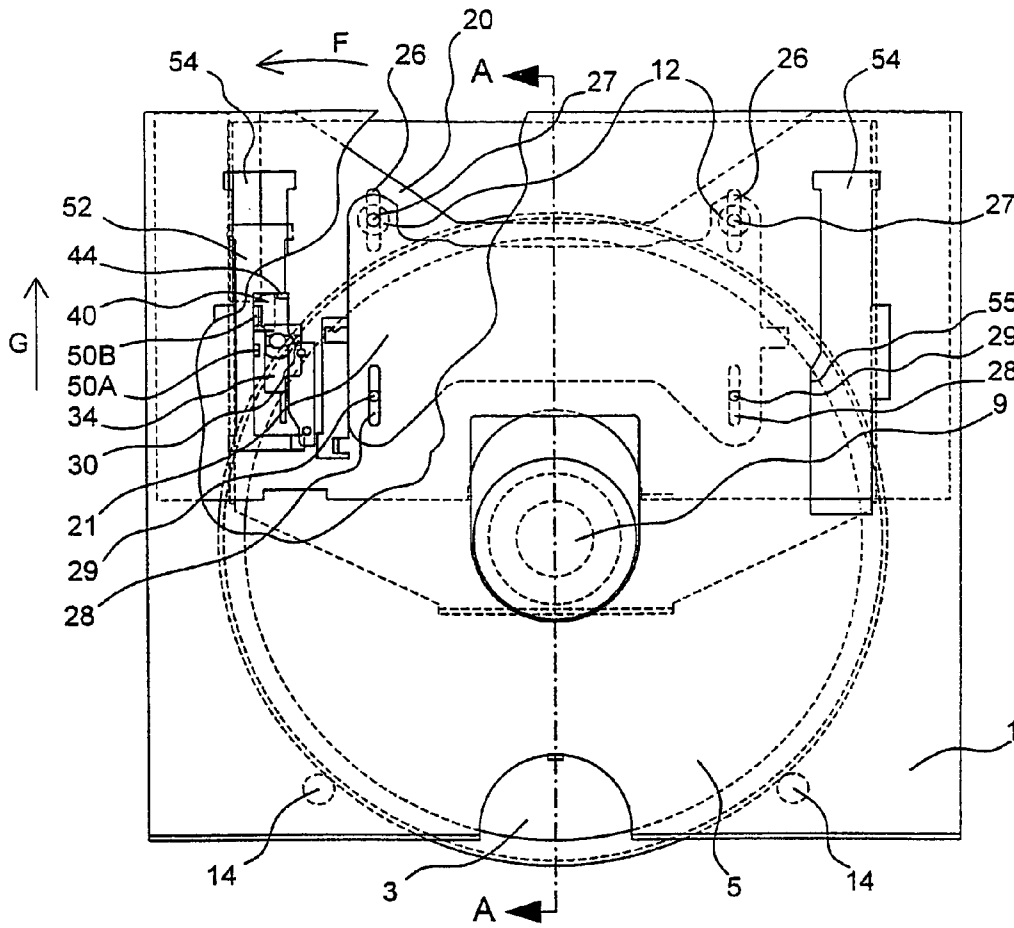

FIG. 7

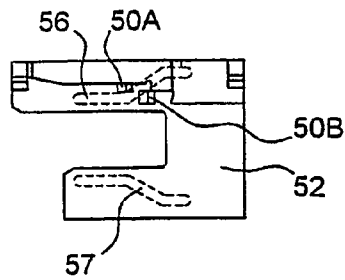

FIG. 8

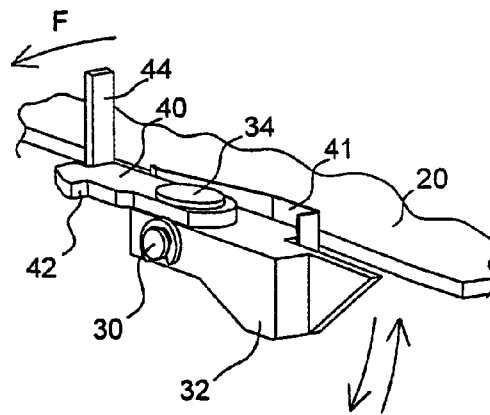

FIG. 1A

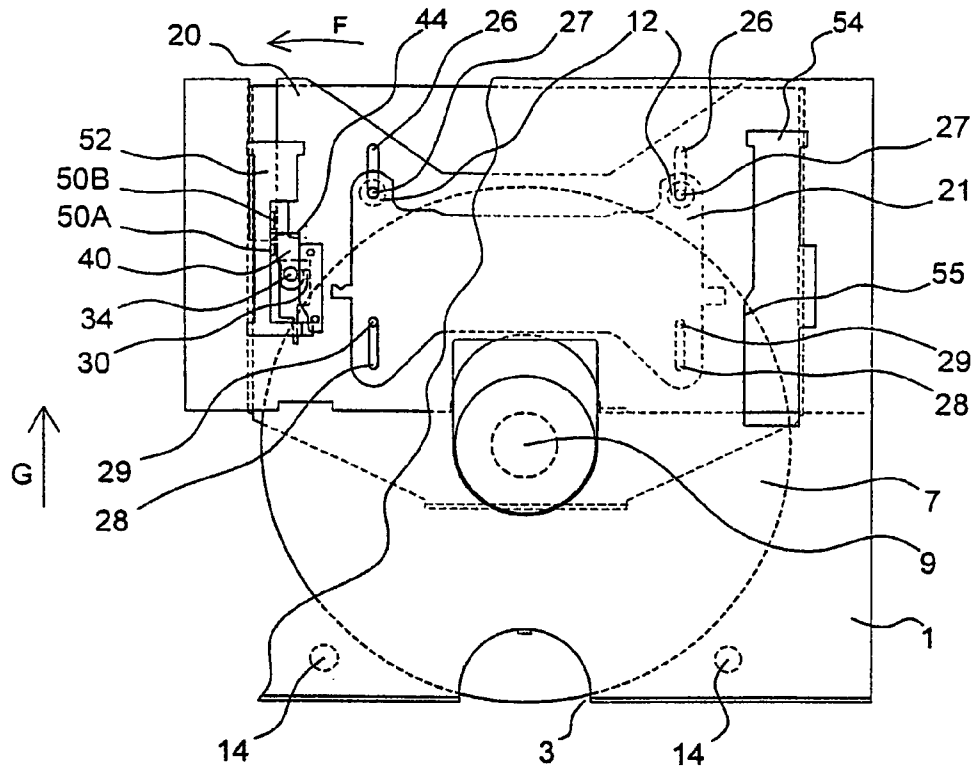

FIG. 2

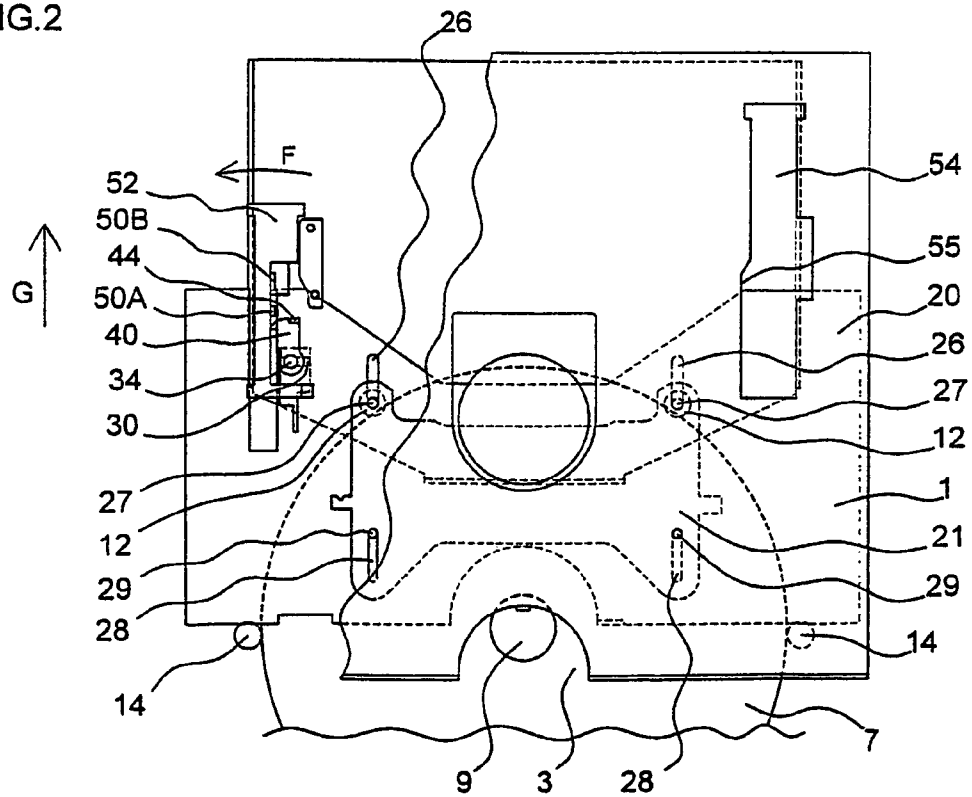

FIG.4A

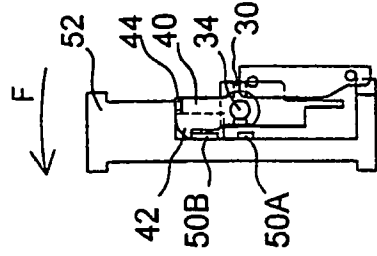

FIG.4

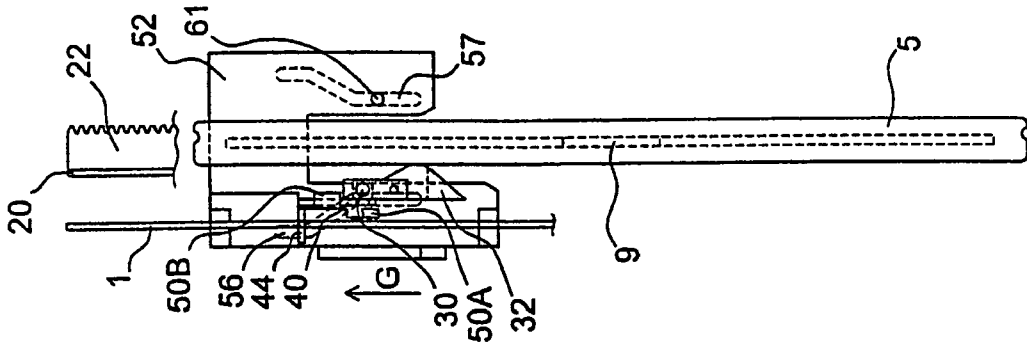

FIG.3

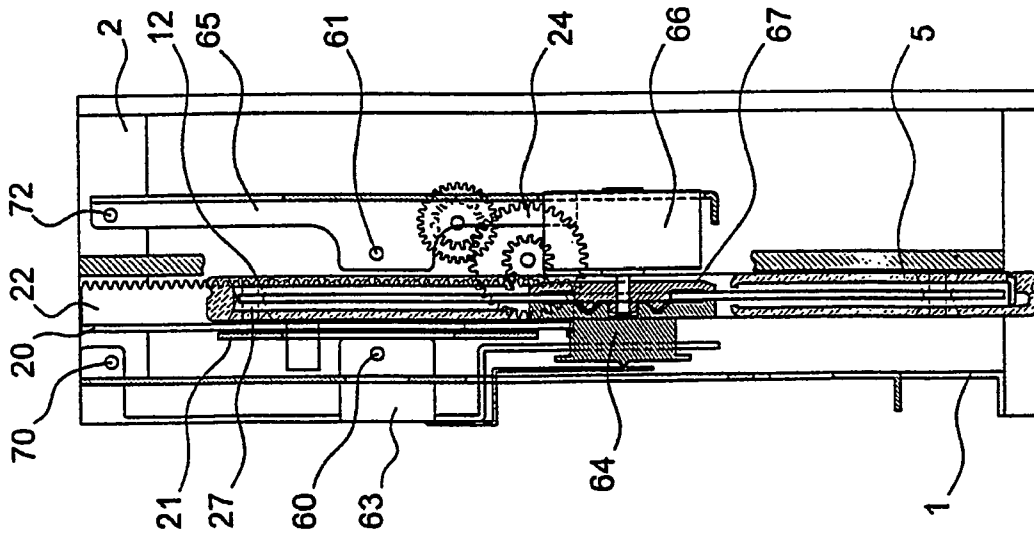

FIG.6A

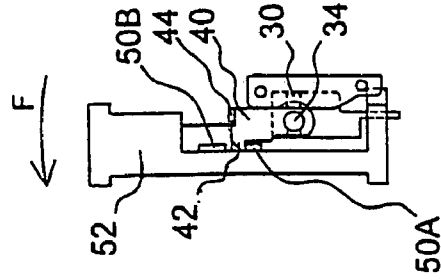

FIG.6

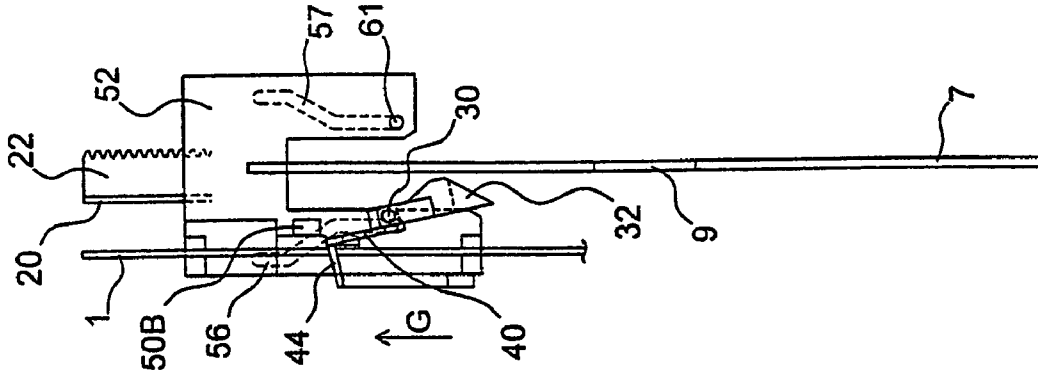
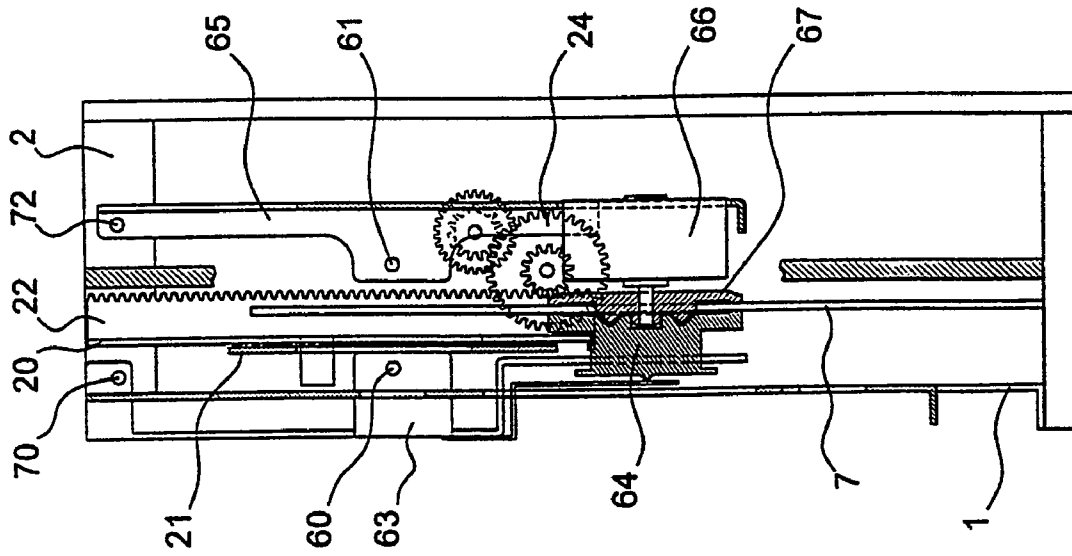

FIG.5



1

TRANSFER DEVICE FOR INFORMATION CARRIERS

FIELD OF THE INVENTION

The present invention relates to transfer devices ensuring the loading/unloading of information carriers in/from record and/or playback apparatuses and particularly to such devices for information carriers of a substantially circular periphery such as optical, magnetic discs, CD, DVD. The present invention relates more particularly to transfer devices for those information carriers appearing in two configurations different in size and/or thickness as, for instance, bare discs and discs housed in protective cartridges such as the one disclosed in U.S. Pat. No. 6,377,538, which is assigned to the same assignee as the present invention.

BACKGROUND OF THE INVENTION

Transfer devices have been developed for information carriers of different configurations. For example, the transfer devices disclosed in U.S. Pat. No. 5,867,338 and EPA 1.087.388 ensure the loading of bare discs and cartridges holding discs. However, these devices involve either elements selected by the user himself before he inserts the carrier (U.S. Pat. No. 5,867,338) or a loading mechanism adapted to each type of carrier (EPA 1.087.388), for instance one loading mechanism for bare discs and another loading mechanism for discs housed in cartridges. Such devices are thus complex, expensive and require a lot of space.

SUMMARY OF THE INVENTION

The aim of the present invention is to overcome the above-mentioned drawbacks by providing a single, simple, low cost, reliable, compact device that ensures the transfer of information carriers having substantially the same profile, but having configurations different in size and/or thickness, by adapting, during said transfer, simultaneously and automatically the driving and clamping mechanisms of the apparatus to the inserted information carrier.

A further aim of the invention is to utilize, by controlling them differently, mechanisms already provided in transfer devices to limit the increase of parts, the additional cost, the overall height and the required space.

Another aim of the invention is to avoid requiring any specific manipulation/selection by the user before he inserts a carrier into the apparatus.

Further characteristics, advantages, particularities of the invention will appear from the preferred embodiment, hereafter described in a non-limiting way and to which further improvements, modifications can be brought without departing from the scope of the invention, in conjunction with the drawings for which:

BRIEF DESCRIPTION OF THE DRAWINGS

FIG. 1 is a schematic top view of an exemplary apparatus incorporating a transfer device according to the present invention with a portion of the frame being cut away for clarity and the apparatus being in the operative playback position for a disc housed in a cartridge.

FIG. 1A is a partial top view of an apparatus incorporating a transfer device according to the present invention similar to FIG. 1 (but in somewhat smaller scale) with the information carrier being a bare disc.

2

FIG. 2 is a partial top view of the apparatus of FIG. 1A with the apparatus being in its inoperative position of ejection/insertion.

FIG. 3 is a partial cross-sectional view of the apparatus of FIG. 1 taken in the plane of line A—A of FIG. 1.

FIG. 4 is a simplified drawing of the cross-sectional view of FIG. 3 in which only the key elements of the transfer device are shown.

FIG. 4A is a top view of a portion of the linking element and slider shown in FIG. 4.

FIG. 5 is a cross-sectional view similar to the view of FIG. 3 of an apparatus and transfer device configured to handle a bare disc.

FIG. 6 is a simplified cross-sectional view similar to FIG. 3 of the apparatus and transfer device of FIG. 5.

FIG. 6A is a top view of a portion of the linking element and slider shown in FIG. 6 (similar to FIG. 4A).

FIG. 7 is a view of a slider of a transfer device according to the invention.

FIG. 8 is a perspective view of a linking element of a transfer device according to the invention.

For clarity and simplicity purposes, only the elements strictly necessary for the understanding of the invention appear on each figure.

DETAILED DESCRIPTION OF THE INVENTION

In the illustrated embodiment, the information carrier is a standard optical disc such as a CD, DVD, etc. also called a compact disc, digital video disc, used either bare (for carriers having a small thickness) or enclosed in a cartridge (for carriers having different dimensions such as a thickness and diameter larger than those of a bare disc) similar to the cartridge described in U.S. Pat. No. 6,377,538, which is assigned to the same assignee as the present invention.

Turning to the figures, the apparatus incorporating the transfer device comprises a fixed frame 1 provided with a semi-circular opening 3 allowing an easy pick-up of an information carrier 5, 7 by its central hole 9 in the eject position (FIG. 2). The apparatus comprises notably two pairs of mobile rollers 12, 14 having V-shaped profiles powering an appropriate centering of the information carrier 5, 7 during its transfer. The rollers 12, 14 are not essential elements for understanding the invention, and thus they appear schematically in the drawings. By the way, any other centering mechanism could be utilized. The transfer device includes a mobile frame 20 bearing a rack 22 (FIGS. 3 to 6) powered by a micro-motor (not shown) through a gear train 24. This mobile frame 20 supports a sub-frame 21 that also is mobile thanks to the combination, on one hand, of grooves 26 provided in the frame 20 and shafts 27 set on the sub-frame 21 (the shafts 27 bearing one pair of rollers 12) and on the other hand, of grooves 28 provided in the sub-frame 21 and studs 29 set on the frame 20. The mobile frame 20 bears laterally a pair of support elements 30, such as shafts (only the left one is shown) around which a detection mechanism can move, in this case pivot, such as feelers 32 (FIGS. 4, 6, 8) provided with resilient elements (not shown), urging them to pivot anti-clockwise. Each feeler 32 bears a shaft 34 around which linking elements 40, such as a ratchet, can rotate under the action of a resilient element 41, such as a leaf spring, urging a pivotal movement in the direction of the arrow F (FIGS. 1 to 2, 4A, 6A, 8). So, the detection elements or feelers 32 may pivot in a substantially vertical plane while the linking elements or ratchets 40 may pivot in plane different from that of the feelers 32, in

this case in a substantially perpendicular plane. The ratchets **40** bear a profile **42** at one of their ends. The profile **42** is shaped as a hook (FIGS. **4A**, **6A**, **8**) that cooperates with discontinuities such as projections **50A**, **50B** (FIGS. **4**, **6**, **7**) that, preferably and for the simplicity of the device, are integral with sliders **52** (only the left one is shown) supported and guided by openings **54** provided in the fixed frame **1** (FIG. **1**). The projections **50A**, **50B** are set at spaced-apart positions or levels (FIG. **7**).

Each slider **52** bears two grooves **56**, **57** (FIG. **7**) on the external side opposite to that bearing the projections **50A**, **50B**. The grooves **56**, **57** have a S-shaped profile for guiding studs **60**, **61** (FIGS. **3**, **4**, **5**, **6**), respectively supported by a clamping mechanism **63**, utilizing for instance a magnet **64** (FIGS. **3**, **5**), by a driving mechanism **65**, including for instance a motor **66** bearing a turntable **67** supporting the information carrier **5**, **7**. The clamping and driving mechanisms pivot around fixed shafts **70**, **72** supported by the lateral sides **2** of the apparatus. So, during the loading of the support, each slider **52**, while moving longitudinally, ensures that the clamping **63** and driving **65** mechanisms pivot around their shafts **70**, **72** to clamp and drive the information carrier **5**, **7** when it is to be set in operative position, whether said carrier is a bare disc **7** or a cartridge **5** (FIGS. **3**, **5**). Upon ejection of the information carrier **5**, **7**, the sliders **52** ensure the pivoting of the clamping **63** and driving **65** mechanisms in the opposite direction to move them away from the carrier and thus allow its transfer to its inoperative position of ejection/insertion. Of course, one can imagine that only one of the clamping and driving mechanisms is movable as it is their relative movement which sets the information carrier **5**, **7** in its operative, inoperative positions.

The ratchets **40** and projections **50A**, **50B** on the sliders **52** synchronize the mobile frame **20** powered by the rack **22** with the means setting the operative position, for instance the clamping **63** and driving **65** mechanisms such as disclosed hereafter.

Upon the loading of an information carrier **7** having a small thickness—for example a bare disc—the feelers **32** (FIG. **6**) remain at their lower level under the action of their resilient elements, a level at which they do not enter into contact with the surface of the information carrier **7** while the ratchets **40** are thus at their higher position. So, the hooks **42** cooperate with the projections **50A** (FIGS. **6**, **6A**) to connect the movement of each slider **52** to that of the rack **22** and the mobile frame **20**.

During the loading of an information carrier **5** having a larger thickness—for example a cartridge—said carrier encounters the feelers **32** which then pivot around their shaft **30** against their resilient elements (FIG. **4**) to move the ratchets **40** downwards and thus force their hooks **42** to cooperate with the projections **50B** (FIGS. **4**, **4A**) in order to connect the movement of each slider **52** to that of the rack **22** but with a delay as compared to an information carrier **7** having a small thickness.

The setting of the hooks **42** is such that they are locked on the projections **50A**, **50B** when the mobile frame **20** is shifted in the direction of the arrow **G** (FIGS. **1** to **2**, **4**, **6**). The pivoting shafts **34** of the feelers are located in-between the hooks **42** and their driving mechanism, that is to say the mobile frame **20**. Moreover, each ratchet **40** includes a substantially vertical leg **44** (FIG. **8**) protruding of openings **54** provided in the fixed frame **1** (FIGS. **1**, **1A**) and of a profile which locks said leg **44** to prevent any pivoting of the

ratchets **40** and thus to ensure the effective locking of the hooks **42** on the projections **50A**, **50B** in case of vibration or shock.

Thus, the feelers **32** and the ratchets **40** ensure the synchronization between the transfer of the information carriers **5**, **7** and the means ensuring their setting in operative position, in the illustrated embodiment, the clamping **63** and driving **65** mechanisms, by utilizing a single mechanism requiring no particular care or manipulation from the user.

During the ejection or the unloading of an information carrier **7** having a small thickness—e.g., a bare disc—the sliders **52** are shifted in synchronism with the rack **22** in the direction opposite to that of the arrow **G**. The profile of the hooks **42** is such that the force imparted by the mobile frame **20** on the ratchets **40** tends to pivot them in the direction opposite to that of the arrow **F** for disengaging them from the projections **50A**. However, this movement is opposed by the profile of the openings **54** locking the leg **44** of the ratchet **40** for preventing any pivoting. Said carrier **7** is then totally free from its clamping **63** and driving **65** mechanisms. Simultaneously, the clearance **55**, provided in the profile of each opening **54** (FIGS. **1** to **2**), unlocks the leg **44**, thus allowing the ratchet **40** to pivot around the shaft **34** and, as a result, the hooks **42** to disengage from the projections **50A**. The ratchets **40** are then disconnected from the sliders **52**. The mobile frame **20**, powered by the rack **22**, allows the information carrier **7**, supported by the pairs of rollers **12**, **14**, to be ejected from the apparatus for being picked-up by its central hole **9**. Once the carrier has been removed, the feelers **32** remain pivoted in their lower position under the action of their resilient elements. Thus, the ratchets **40** stay at their higher position, ready for the insertion of an information carrier **5** or **7**.

Upon the unloading of an information carrier **5** of a larger thickness—e.g., a cartridge—the sliders **52** are shifted in sync with the rack **22** in the direction opposite to that of the arrow **G**. In the same way, the profile of the hooks **42** enables the traction effort generated by the mobile frame **20** to pivot said hooks in the direction opposite to that of the arrow **F** to disengage them from the projections **50B**. However, this movement is opposed again by the profile of each opening **54** locking the leg **44** of the ratchets **40**. Said carrier **5** is then totally free from its clamping **63** and driving **65** mechanisms. Simultaneously, the clearance **55**, provided in the profile of each opening **54**, unlocks the legs **44**, allowing the hooks **42** to disengage from the projections **50B** and thus the ratchets **40** to pivot and move away from the sliders **52**. The mobile frame **20**, powered by the rack **22**, allows the information carrier **5**, supported by the pairs of rollers **12**, **14**, to be ejected from the apparatus for being picked-up by its central hole **9**. The feelers **32**, once the carrier **5** has been removed, pivot counterclockwise towards their lower position under the action of their own resilient elements, as a result, the ratchets **40** are set at their higher position, ready for the insertion of an information carrier **5** or **7**.

REFERENCE NUMBERS

- 1** fixed frame
- 2** lateral walls
- 3** opening
- 5,7** information carrier
- 9** central hole of **5**, **7**
- 12, 14** mobile rollers
- 20** mobile frame
- 21** sub-frame
- 22** rack

5

- 24 gears train
- 26 groove
- 27 shaft
- 28 groove
- 29 stud
- 30 support element, shaft
- 32 detection mechanism/feeler
- 34 shaft
- 40 linking element/ratchet
- 41 resilient element/leaf spring
- 42 profile/hook
- 44 leg
- 50A, 50B projection
- 52 slider
- 54 opening
- 55 clearance
- 56, 57 groove
- 60, 61 stud
- 63 clamping mechanism
- 64 magnet
- 65 driving mechanism
- 66 motor
- 67 turntable

What is claimed is:

- 1. A transfer device for information carriers of different sizes comprising:
 - a mobile frame for ensuring the transfer of an inserted information carrier, the mobile frame cooperating with a slider that ensures the setting of the inserted information carrier in an operative position;
 - a detection mechanism cooperating with the inserted information carrier;
 - a mobile linking element associated with the detection mechanism; and
 - a plurality of projections provided on the slider, the projections being arranged at spaced-apart positions

6

- 5 corresponding to the different sizes of information carriers, the mobile linking element cooperating with the projections to establish a connection between the mobile frame and the slider to ensure the transfer and the setting in operative position of the information carrier.
- 2. A transfer device according to claim 1, wherein the detection mechanism comprises feelers that pivot around support elements supported by the mobile frame.
- 10 3. A transfer device according to claim 2, wherein the linking element pivots in a plane substantially perpendicular to the plane in which the detection mechanism pivots.
- 15 4. A transfer device according to claim 1, wherein the linking element includes ratchets that are movable relative to the detection mechanism.
- 20 5. A transfer device according to claim 4, wherein the linking element includes a pivoting shaft and hooks and the pivoting shaft is located between the hooks and the mobile frame.
- 6. A transfer device according to claim 1, wherein the slider supports the projections located at spaced-apart positions.
- 7. A transfer device according to claim 1, wherein the linking element bears a leg that is arranged substantially vertically.
- 8. A transfer device according to claim 7, wherein a fixed frame includes openings having a profile that locks the leg to prevent any pivoting of the linking element.
- 30 9. A transfer device according to claim 8, wherein a clearance is provided in the profile of each opening to unlock the leg and thus let the linking element disengage from the projections.

* * * * *