

(19) World Intellectual Property Organization
International Bureau



(43) International Publication Date
6 January 2011 (06.01.2011)

(10) International Publication Number
WO 2011/002362 A1

(51) International Patent Classification:
H02M 1/44 (2007.01) *H02M 7/23* (2006.01)
H02M 7/493 (2007.01) *H02M 7/77* (2006.01)
H02M 7/17 (2006.01) *H02M 7/81* (2006.01)

(21) International Application Number:
PCT/SE2009/050844

(22) International Filing Date:
30 June 2009 (30.06.2009)

(25) Filing Language: English

(26) Publication Language: English

(71) Applicant (for all designated States except US): SAAB AB [SE/SE]; S-581 88 Linköping (SE).

(72) Inventor; and

(75) Inventor/Applicant (for US only): NETTELBLAD, Bo [SE/SE]; Svensksundsgatan 1a, S-416 61 Göteborg (SE).

(74) Agent: ALBIHNS AB; Valhallavägen 117, P.O. Box 5581, S-114 85 Stockholm (SE).

(81) Designated States (unless otherwise indicated, for every kind of national protection available): AE, AG, AL, AM, AO, AT, AU, AZ, BA, BB, BG, BH, BR, BW, BY, BZ, CA, CH, CL, CN, CO, CR, CU, CZ, DE, DK, DM, DO,

DZ, EC, EE, EG, ES, FI, GB, GD, GE, GH, GM, GT, HN, HR, HU, ID, IL, IN, IS, JP, KE, KG, KM, KN, KP, KR, KZ, LA, LC, LK, LR, LS, LT, LU, LY, MA, MD, ME, MG, MK, MN, MW, MX, MY, MZ, NA, NG, NI, NO, NZ, OM, PE, PG, PH, PL, PT, RO, RS, RU, SC, SD, SE, SG, SK, SL, SM, ST, SV, SY, TJ, TM, TN, TR, TT, TZ, UA, UG, US, UZ, VC, VN, ZA, ZM, ZW.

(84) Designated States (unless otherwise indicated, for every kind of regional protection available): ARIPO (BW, GH, GM, KE, LS, MW, MZ, NA, SD, SL, SZ, TZ, UG, ZM, ZW), Eurasian (AM, AZ, BY, KG, KZ, MD, RU, TJ, TM), European (AT, BE, BG, CH, CY, CZ, DE, DK, EE, ES, FI, FR, GB, GR, HR, HU, IE, IS, IT, LT, LU, LV, MC, MK, MT, NL, NO, PL, PT, RO, SE, SI, SK, TR), OAPI (BF, BJ, CF, CG, CI, CM, GA, GN, GQ, GW, ML, MR, NE, SN, TD, TG).

Declarations under Rule 4.17:

— as to applicant's entitlement to apply for and be granted a patent (Rule 4.17(ii))

Published:

— with international search report (Art. 21(3))

(54) Title: METHOD FOR REDUCING ELECTROMAGNETIC INTERFERENCE RADIATED FROM A POWER SUPPLY ARRANGEMENT

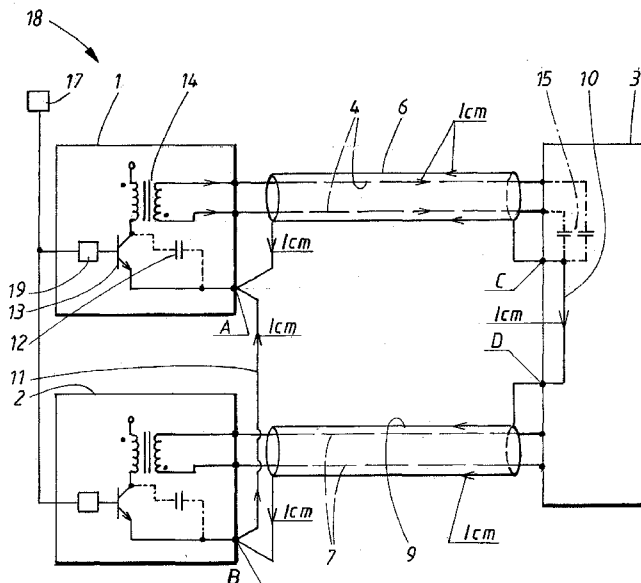

FIG. 1

(57) Abstract: The present invention relates to a method for reducing electromagnetic interference radiated from a power supply arrangement comprising a plurality of switching mode power supply units (1, 2) connected to an external device (3), wherein each switching mode power supply unit (1, 2) comprises a ground point (A, B). The radiate electromagnetic interference is reduced by synchronizing a switching frequency of each switching mode power supply unit (1, 2), such that all of said synchronized switching mode power supply units (1, 2) have an identical switching frequency, thereby reducing the difference in electric potential between said ground points (A, B). The present invention also relates to a corresponding power supply arrangement.



WO 2011/002362 A1

Method for reducing electromagnetic interference radiated from a power supply arrangement

TECHNICAL FIELD

5 The present invention relates to a method for reducing electromagnetic interference radiated from a power supply arrangement comprising a plurality of switching mode power supply units connected to an external device. The present invention also relates to a power supply arrangement, which is configured to radiate less electromagnetic interference, and which comprises
10 a plurality of switching mode power supply units connected to an external device.

BACKGROUND ART

Prior art power supply arrangements comprising a plurality of switching mode
15 power supply units connected in parallel to one or several loads by means of shielded conductors generate high electromagnetic interference (EMI). Said EMI can degrade the performance of adjacent electrical or electronic equipment. The terms noise and radio-frequency interference (RFI) are sometimes used in the same context. The EMI generated by the power
20 supply system can be propagated either by conduction via the input and output conductors, by the ground points, or by radiation from the casings and/or conductors.

The known solution to this problem is to apply filters to the output terminals of
25 each power supply unit and/or input terminals of the at least one load. These filters however bring about several problems: They are bulky and have relatively high weight. This problem also increases with the amount of power supplied by the power supply unit, mainly because of the magnetic filter components. This is particularly disadvantageous in airborne, space and
30 other applications where weight and size are important factors. Another problem is that extensive testing of filter component combinations is necessary to accomplish adequate power supply noise reduction, because

filter components are not ideal. It is also necessary to perform measurements on the individual power supply units connected in parallel to at least one load to determine if the power supply units comply with EMI regulations. This implies that for testing purposes, you need one filter prototype for each power supply unit in your power supply system. Testing and verification is thus
5 costly and labour intensive.

There is consequently a need for a method for reducing electromagnetic interference radiated from a power supply arrangement, as well as for an
10 improved power supply arrangement, which overcomes the above mentioned problems.

SUMMARY

The object of the invention is to provide an inventive method and power supply arrangement comprising a plurality of switching mode power supply units connected to an external device, wherein each switching mode power supply unit comprises a ground point, where the previously mentioned
15 problems are avoided.

20 This object is achieved by the inventive method for reducing electromagnetic interference radiated from a power supply arrangement according to claim 1, by synchronizing a switching frequency of each switching mode power supply unit, such that all of said synchronized switching mode power supply units have an identical switching frequency, thereby reducing the difference in
25 electric potential between said ground points.

This object is also achieved by a power supply arrangement for reducing electromagnetic interference radiated from said power supply arrangement according to claim 8, wherein the power supply arrangement comprises
30 synchronization means, which is configured to synchronize a switching frequency of each switching mode power supply unit, such that all of said synchronized switching mode power supply units have an identical switching

frequency, whereby the difference in electric potential between the ground points is reduced.

Further advantageous aspects of the invention are provided by the
5 dependent claims.

BRIEF DESCRIPTION OF THE DRAWINGS

The invention will below be described in connection to a number of drawings, wherein;

10 Figure 1 shows schematically a switching mode power supply system connected to an external device;

Figure 2 shows schematically a system according to figure 1, where a common-mode current is returning mainly in a shield not belonging to the power supply generating said common-mode current; and

15 Figure 3 shows schematically a system according to figure 1, where a common-mode current is returning mainly in a shield belonging to the power supply generating said common-mode current.

DETAILED DESCRIPTION

20 Figure 1 shows a power supply system 18 comprising a first and second switching mode power supply units 1, 2, hereinafter called power supply units 1, 2. Each power supply unit 1, 2 is connected to an external electrical device 3, hereinafter called external device 3. The first power supply unit 1 is connected to the external device 3 by means of first conductors 4, which are
25 surrounded by a first electrically conducting shield 6. The first shield 6 is connected to a first ground point A associated with the first power supply unit 1, and to a third ground point C associated with the external device 3.

Correspondingly, the second power supply unit 2 is connected to the external
30 device 3 by means of second conductors 7, which are surrounded by a second electrically conducting shield 9. The second shield 9 is connected to a second ground point B associated with the second power supply unit 2, and

to a fourth ground point D associated with the external device 3. The third and fourth ground points C and D of the external device are mutually connected by means of a first common ground connection 10 associated with the external device, whereas the first and second ground points A and B of the power supply units 1, 2 are mutually connected by means of a second common ground connection 11 associated with the power supply system 18. The power supply system 18 and the external device 3 are thus separately grounded. Said first to fourth ground points A – D can be realised by a connection to the chassis of the associated equipment.

10

Third and fourth ground points C and D at the external device 3 can of course alternatively be the same point, in which case the first common connection 10 between said ground points C, D becomes superfluous. The invention is not limited to an arrangement where the plurality of power supply units are connected to an external device 3 comprising a single unit, but incorporates also the example where the plurality of power supply units 1, 2 are connected to a plurality of units associated with the external device 3. In such case, the ground points of the plurality of units associated with the external device are mutually connected by a first common ground connection, associated with the external device, such that a current can flow in said first common ground connection between said plurality of units.

20

The external device 3 can represent a load, a radar unit, a generator, a control unit, or any other type of electrical device. The invention is furthermore not limited to shielded conductors for connecting the external device 3 with the power supply system 18, but said connection can be realised by any type of cable comprising a ground conductor connected to the common ground system of the power supply system 18 as well as the external device 3, for example a three wire cable of which one wire is ground conductor.

30

The first common ground connection 10 of the external device between third and fourth ground points C and D consists of conducting wires, or of a conducting frame element associated with the external device 3, or a combination thereof. Correspondingly, the second common ground
5 connection 11 of the power supply units 1 and 2 between first and second ground points A and B consists of conducting wires, or of a conducting frame element associated with the power supply units 1 and 2, or a combination thereof.

10 A switching mode power supply unit 1, 2 normally suffers from the problem of generating high electromagnetic interference EMI due to its switching characteristics. The EMI generated by the power supply unit 1, 2 can subsequently be propagated to other electrical equipment either by conduction via the electrical terminals, or by radiation from the unit's casing.
15 The problem is more relevant in high power applications, i.e. power supply systems supplying more than 1 kW, or more than 10 kW. Such a power supply system can preferably be used for supplying power to a radar system, especially an airborne radar system, and more specifically a radar system used in an airborne early warning and control system.

20

The invention is based on the finding, that radiated EMI from multiple switching mode power supply units is closely related to the common-mode currents of the power supply arrangement. A common-mode current is an unwanted current that flows into or out of electrical equipment by the ground
25 connections. Furthermore, the amount of radiated EMI is partly a function of a loop area in said power supply arrangement, in which the common-mode currents are flowing, as will be explained hereinafter in more detail.

In figure 1, a common-mode current I_{cm} , generated for example by stray
30 capacitance inside the power transformer 14 of the first power supply 1, will flow in the first conductors 4 from the first power supply 1 to the external device 3. At the external device 3, the common-mode current I_{cm} will flow into

the first common ground connection 10, for example by means of a capacitive coupling between the first conductors 4 and the first common ground connection 10. This coupling is indicated by equivalent capacitances 15. Finally, the common-mode current I_{cm} will return to the first power supply 1 by means of the first shield 6 or the second shield 9 and the second common ground connection 11, forming two current loops.

Theoretically, most of the common-mode current will return in the route having the least impedance, which normally is the shield connected to the power supply unit that generated the common-mode current, but some part of the current will return through other parts, unless there is equal electric potential at first and second ground points A and B in figure 1. In practice, the electric potential at first and second ground points A and B varies with time due to the switching of the switching transistor 13 in the power supply 1. Consequently, the route of the common-mode currents I_{cm} will largely be affected by the difference in electric potential at first and second ground points A and B.

One of the main sources of differential potential at first and second ground points A and B in switched mode power supply units is capacitive coupling of the switching signal between the switching transistor 13 and its heat exchanger. Said capacitive coupling is illustrated by a capacitor 12 in the first power supply unit 1 in figure 1. The heat exchanger is normally attached to the chassis of the power supply units 1, 2, which is connected to the ground of the power supply unit 1. The change in electric potential over time due to the switching signal in each individual power supply units 1 and 2 will consequently be coupled to the first and second ground points A and B respectively.

From the above reasoning, it is immediately apparent that if the individual power supply units 1 and 2 operate with different switching frequencies, the electric potential at first and second ground points A and B will inevitably be

different over time, such that common-mode current I_{cm} generated by power supply 1 will return more or less in the first shield 6 as well as in the second shield 9, all depending in the current electric potential situation.

- 5 Figure 2 shows an example of a plurality of switching mode power supply units 1, 2 connected to an external device 3 having a first common ground connection 10, where the electric potential is lower in the second ground point B than in the first ground point A, such that the common-mode current I_{cm} generated by the first power supply unit 1 will flow in the first conductors 4, and then return via the first common ground connection 10, second shield 9, second common ground connection 11 to ground point A, and finally back to the power transformer 14 of the first power supply 1. This current loop, which conducts high frequency switching currents, will radiate relatively high EMI, because the electro magnetic coupling is a strong function of a current loop area 16, which is delimited by first conductors 4, first common ground connection 10, second shield 9, and second common ground connection 11. This effect can be illustrated by considering the current loop to represent an antenna.
- 10
- 15
- 20 According to the invention, the amount of radiated EMI is reduced by reducing the antenna effect. This is accomplished by attempting to control the generated common-mode currents I_{cm} , such that they will return mainly in the shield belonging to the power supply that generated them. The inventive concept is realized by synchronizing the switching frequencies of the individual power supply units, such that differences in potential over time at first and second ground points A and B will be reduced. If the individual power supply units operate with identical switching frequencies, the difference in potential at first and seconds ground points A and B will be reduced. Such a situation is shown in figure 3, where the switching
- 25
- 30 frequencies are synchronized, such that the potential is nearly identical in first and second ground point A and B. The common-mode current I_{cm} generated in the power transformer 14 of first power supply 1 will

consequently flow in the first conductors 4, and then return via the first shield 6 to the first ground point A, and finally back to the power transformer 14 of the first power supply unit 1. This reduced current loop will, due to the practically non-existing loop area, radiate much less EMI.

5

Synchronization means, which is configured to synchronize the power supply units 1, 2 can be implemented in various ways, for example by means of an external control unit 17, which controls the switching frequency of each power supply unit 1, 2. In that case, synchronization signals will be supplied
10 from the external control unit 17 to a switching regulator 19 of each power unit 1, 2 of the power supply system 18. Said switching regulator 19 subsequently supplies a synchronized switching frequency signal to the switching transistor 13. A more robust design (not shown) for implementing the synchronization means would be to configure one single power supply
15 unit to operate a master unit, which synchronizes the switching frequencies of all remaining slave power supply units in the power supply system by means of synchronization signals supplied to said remaining slave power supply units. The latter design is more robust, since if the master/slave concept fails, the power supply units can continue to operate in an
20 unsynchronized mode.

In certain circumstances, it might be desirable also to synchronize the phase of the oscillating switching frequency signals of each power supply unit 1, 2 of the power supply system 18, in addition to synchronizing the switching
25 frequencies. Additional phase synchronization, such that the switching frequency signals of all power supply units 1,2 exhibit substantially no phase difference, further reduces differences in potential over time at first and second ground point A and B of the power supply system 18. The term substantially above is minimal and refers to occasional synchronization signal
30 propagation delays due to the physical distance between the power supply units 1, 2. The phase synchronization can for example be performed by

means of the external control unit 17 or by means of the master/slave concept described hereinbefore.

5 The external device 3 according to the invention can be represented by a single electrical unit, or by a plurality of electrical units interconnected by means of a first common ground connection 10 associated with the external device 3. The external electrical units can be represented by one or more loads, radar units, generators, control units, or any other type of electrical units.

10

The invention is not limited to a Flyback type of power supply unit 1, 2 as depicted in the figures, but is equally applicable to all types switching mode power supply units, for example Buck, Boost, Forward, Full bridge etc.

15 Furthermore, the invention is not limited to a power supply system 18 comprising only two power supply units 1, 2, but is equally applicable to any number of plural power supply units.

20 Only the common-mode current I_{cm} generated by the first power supply 1 is illustrated in figure 2 and 3, but common-mode currents will be generated by all operating power supply units 1, 2 of the power supply system (18).

The term electric potential at a certain point means the voltage difference between said certain point and the associated common ground point.

25 The first and second electric conductors 4,7 can comprise a pair of conductors, for example for supplying AC or DC to the external device 3, or for receiving AC or DC from the external device 3, or for sending and/or receiving control signals to/from an external device 3.

30 The ground points A, B associated with the power supply units 1,2 can be represented by ground terminal points normally located outside the power supply unit 1,2, together with other terminal means like power output

terminals, control terminals etc. The ground points C, D associated with the external device 3 can be represented by ground terminal points of the external device 3.

- 5 Since figure 2 and 3 merely function to illustrate the common-mode currents I_{cm} in the circuits without or with switching frequency synchronization, neither the details of the power supply units 1, 2 nor the synchronization means are illustrated in the schematic figure 2 and 3.
- 10 The invention is not limited to the embodiments and examples described above, but may vary freely within the scope of the appended claims.

CLAIMS

1. Method for reducing electromagnetic interference radiated from a power supply arrangement comprising a plurality of switching mode power supply units (1, 2) connected to an external device (3), wherein each switching mode power supply unit (1, 2) comprises a ground point (A, B), **characterized by**
- 5
- synchronizing a switching frequency of each switching mode power supply unit (1, 2), such that all of said synchronized switching mode power supply units (1, 2) have an identical switching frequency, thereby reducing the difference in electric potential between said ground points (A, B).
- 10
2. The method according to claim 1, **characterized by**
- 15
- controlling a common-mode current (I_{cm}), generated by each switching mode power supply unit (1, 2), to return mainly in a ground conductor (6, 9) associated with conductors (4, 7) that are connected to the switching mode power supply unit (1, 2) that generated said common-mode current (I_{cm}), such that the generated common-mode current radiates less electromagnetic interference due to a reduced current loop area.
- 20
3. The method according to any previous claim, **characterized by**
- 25
- providing a first ground conductor (6) connected to a first ground point (A) of a first switching mode power supply unit (1), and a second ground conductor (9) connected to a second ground point (B) of a second switching mode power supply unit (2),
- mutually connecting said first and second ground conductors (6, 9) by means of a first common ground connection (10) associated with the external device (3), as well as by means of a second common ground connection (11) associated with the switching mode power supply units (1, 2), thereby providing a ground-loop, comprising first
- 30

ground conductor (6), first common ground connection (10), second ground conductor (9) and second common ground connection (11).

4. The method according to claim 3, **characterized in that** first and second ground conductors (6, 9) are represented by first and second electrically conducting shields (6, 9) surrounding first and second conductors (4, 7) respectively.
5. The method according to any previous claim, **characterized by** synchronizing a phase of a switching frequency signal of each switching mode power supply unit (1, 2) in the power supply arrangement, such that the switching frequency signals of all switching mode power supply units (1, 2) exhibit substantially no phase difference.
6. The method according to any previous claim, **characterized by** synchronizing the switching mode power supply units (1, 2) by means of an external control unit (17) that controls the switching frequency, and optionally also a phase of a switching frequency signal, of each switching mode power supply unit (1, 2) in the power supply arrangement, or by means of a single switching mode power supply unit (1, 2) operating as a master unit, which master unit controls the switching frequencies, and optionally also the phase of switching frequency signals, of all remaining switching mode power supply units (1, 2) in the power supply arrangement.
7. The method according to any previous claims, **characterized in that** the plurality of switching mode power supply units (1, 2) form a power supply system (18), and said power supply system (18) supplies more than 1 kW, preferably more than 10 kW, to at least one external load

(3), wherein said external load (3) is a radar system, especially an airborne radar system.

- 5 8. Power supply arrangement comprising a plurality of switching mode power supply units (1, 2), which are connected to an external device (3), wherein each switching mode power supply unit (1, 2) comprises a ground point (A, B), **characterized in that** the power supply arrangement comprises synchronization means, which is configured to synchronize a switching frequency of each switching mode power supply unit (1, 2), such that all of said synchronized switching mode power supply units (1, 2) have an identical switching frequency, whereby the difference in electric potential between the ground points (A, B) is reduced.
- 10
- 15 9. The power supply arrangement according claim 8, **characterized in that** the power supply arrangement comprises synchronization means, which is configured to control a potential common-mode current (I_{cm}) generated by each switching mode power supply unit (1, 2) to return mainly in a ground conductor (6, 9) associated with conductors (4, 7) that are connected to the switching mode power supply unit (1, 2) that generated said common-mode current (I_{cm}), such that a potential common-mode current (I_{cm}) generated by the power supply arrangement radiates less electromagnetic interference due to a reduced current loop area.
- 20
- 25
- 30 10. The power supply arrangement according to any of claims 8 to 9, **characterized in that** the power supply arrangement comprises synchronization means, which is configured to synchronize a phase of a switching frequency signal of each switching mode power supply unit (1, 2) of the power supply arrangement, such that switching frequency signals of all switching mode power supply units (1, 2) are arranged to exhibit substantially no phase difference, whereby the

difference in electric potential between the ground points (A, B) associated with each switching mode power supply unit (1, 2) is further reduced.

5 11. The power supply arrangement according to any of claims 8 to 10, **characterized in that** the synchronization means, which is arranged to synchronize the switching mode power supply units (1, 2), comprises

10 an external control unit (17), which is configured to control the switching frequency, and optionally also a phase of a switching frequency signal, of each switching mode power supply unit (1, 2) in the power supply arrangement, or

15 a single switching mode power supply unit (1, 2) that is configured to operate as a master unit, which master unit is configured to control the switching frequencies, and optionally also a phase of switching frequency signals, of the remaining slave switching mode power supply units (1, 2) in the power supply arrangement.

20 12. The power supply arrangement according to any of claims 8 to 11, **characterized in that**

a first ground conductor (6) is connected to a first ground point (A) of a first switching mode power supply unit (1),

a second ground conductor (9) is connected to a second ground point (B) of a second switching mode power supply unit (2),

25 said first and second ground conductors (6, 9) are mutually connected by means of a first common ground connection (10) associated with the external device (3), as well as by means of a second common ground connection (11) associated with the switching mode power supply units (1, 2), thereby providing a ground-loop, comprising first ground conductor (6), first common ground connection (10), second ground conductor (9) and second common ground connection (11).

30

13. The power supply arrangement according to any of claims 8 to 12,
characterized in that the external device (3) can be represented by
one or more load units, generator units, control units, or any other type
of electrical units.

14. The power supply arrangement according to any of claims 8 to 13,
characterized in that
a first power supply unit (1) is connected to the external device
(3) by means of first conductors (4) and a first ground conductor (6),
a second power supply unit (2) is connected to the external
device (3) by means of second conductors (7) and a second ground
conductor (9), and
the first and second ground conductors (6, 9) are represented by
first and second electrically conducting shields (6, 9) surrounding first
and second conductors (4, 7) respectively.

15. The power supply arrangement according to any of claims 8 to 14,
characterized in that the plurality of switching mode power supply
units (1, 2) form a power supply system (18), which is configured to
supply more than 1 kW, preferably more than 10 kW, to at least one
external load (3), wherein said external load (3) is a radar system,
especially an airborne radar system.

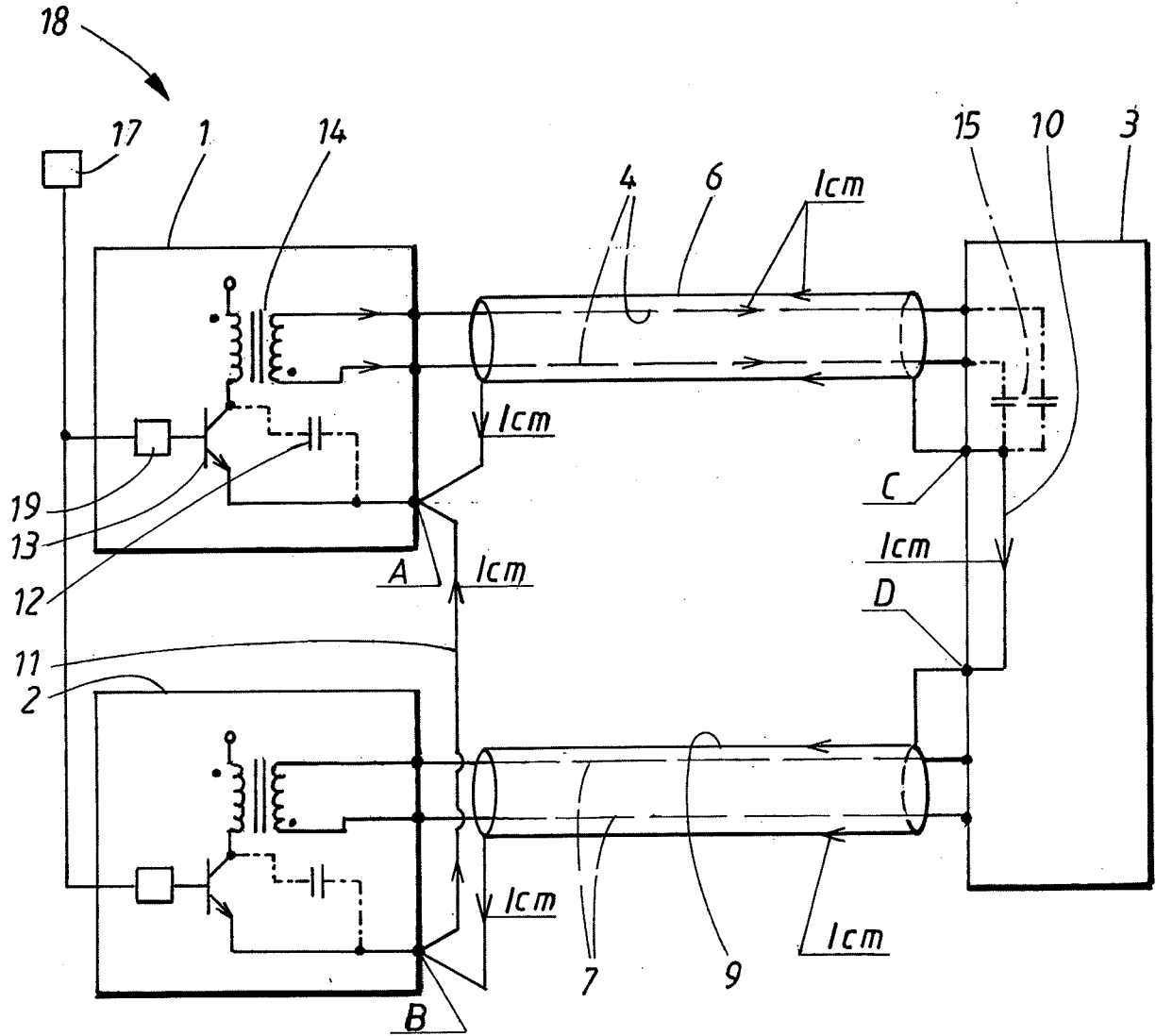

FIG. 1

2/3

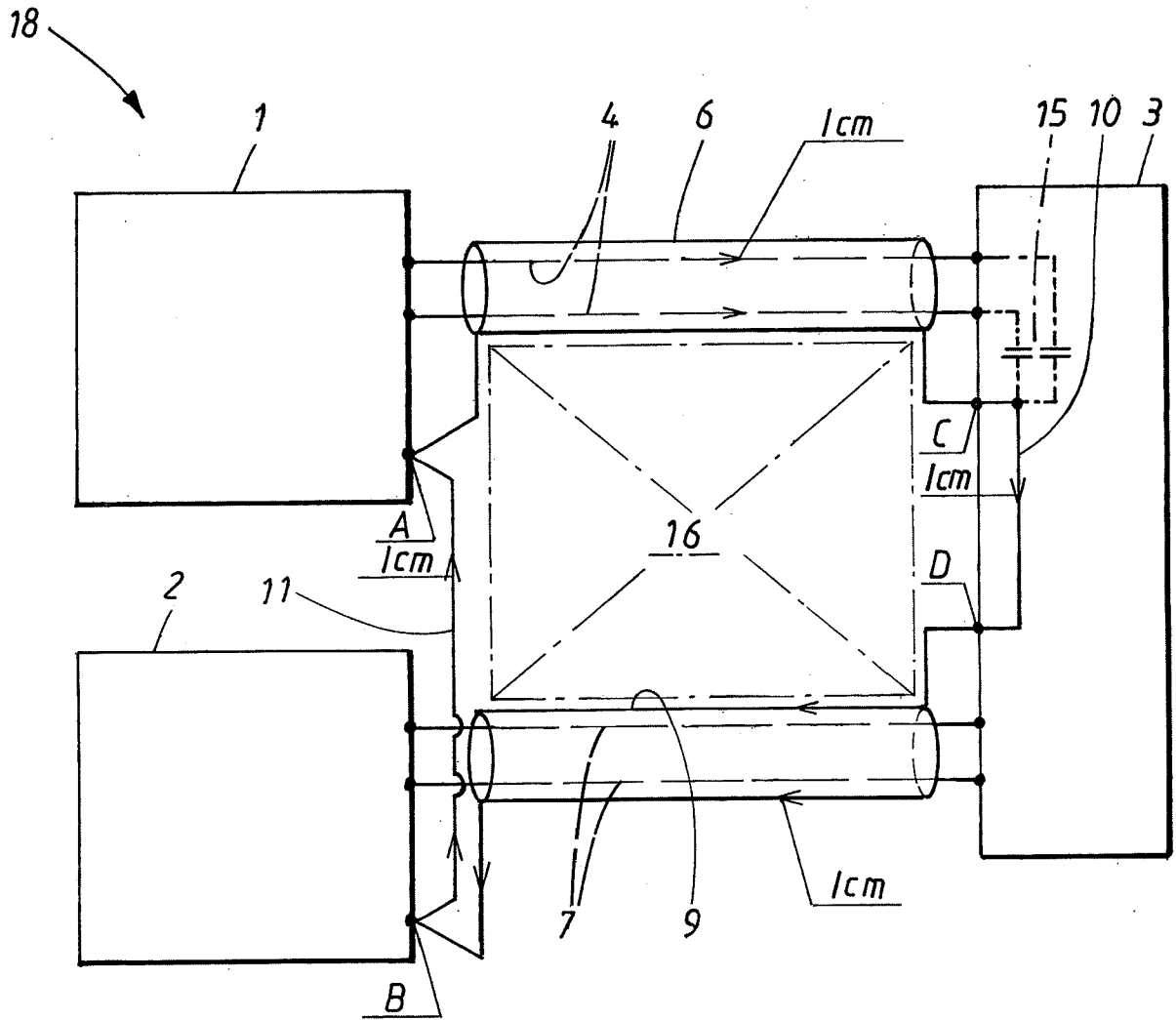

FIG. 2

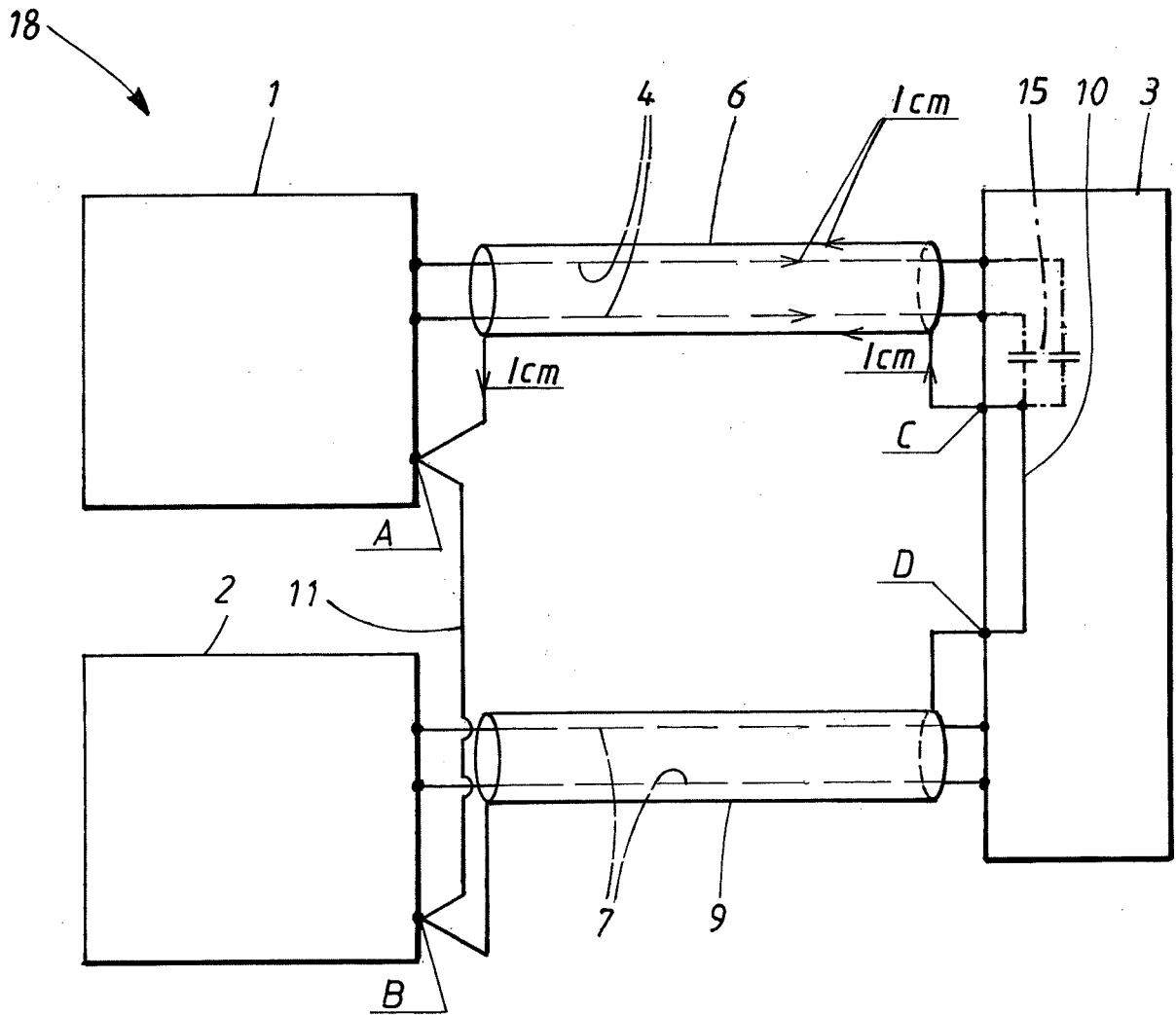

FIG. 3

INTERNATIONAL SEARCH REPORT

International application No.

PCT/SE2009/050844

A. CLASSIFICATION OF SUBJECT MATTER

IPC: see extra sheet

According to International Patent Classification (IPC) or to both national classification and IPC

B. FIELDS SEARCHED

Minimum documentation searched (classification system followed by classification symbols)

IPC: H02M

Documentation searched other than minimum documentation to the extent that such documents are included in the fields searched

SE,DK,FI,NO classes as above

Electronic data base consulted during the international search (name of data base and, where practicable, search terms used)

EPO-INTERNAL, WPI DATA, PAJ

C. DOCUMENTS CONSIDERED TO BE RELEVANT

Category*	Citation of document, with indication, where appropriate, of the relevant passages	Relevant to claim No.
X	EP 1983641 A2 (ROCKWELL AUTOMATION TECHNOLOGIES, INC.), 22 October 2008 (22.10.2008), paragraphs (0003)-(0010) --	1-4,6-9, 11-15
X	US 6118680 A (K.A. WALLACE ET AL), 12 Sept 2000 (12.09.2000), column 5, line 25 - line 43 --	1-5,7-10, 12-15
A	EP 1575156 A2 (VACON OYJ), 14 Sept 2005 (14.09.2005), abstract --	1-15
A	US 5257180 A (N. SASHIDA ET AL), 26 October 1993 (26.10.1993), abstract --	1-15

 Further documents are listed in the continuation of Box C. See patent family annex.

* Special categories of cited documents:

"A" document defining the general state of the art which is not considered to be of particular relevance

"E" earlier application or patent but published on or after the international filing date

"L" document which may throw doubts on priority claim(s) or which is cited to establish the publication date of another citation or other special reason (as specified)

"O" document referring to an oral disclosure, use, exhibition or other means

"P" document published prior to the international filing date but later than the priority date claimed

"T" later document published after the international filing date or priority date and not in conflict with the application but cited to understand the principle or theory underlying the invention

"X" document of particular relevance: the claimed invention cannot be considered novel or cannot be considered to involve an inventive step when the document is taken alone

"Y" document of particular relevance: the claimed invention cannot be considered to involve an inventive step when the document is combined with one or more other such documents, such combination being obvious to a person skilled in the art

"&" document member of the same patent family

Date of the actual completion of the international search

18 February 2010

Date of mailing of the international search report

16-03-2010

Name and mailing address of the ISA/
Swedish Patent Office
Box 5055, S-102 42 STOCKHOLM
Facsimile No. +46 8 666 02 86

Authorized officer

Tomas Erlandsson / MRO
Telephone No. +46 8 782 25 00

INTERNATIONAL SEARCH REPORT

International application No.

PCT/SE2009/050844

C (Continuation). DOCUMENTS CONSIDERED TO BE RELEVANT

Category*	Citation of document, with indication, where appropriate, of the relevant passages	Relevant to claim No.
A	US 20080265680 A1 (M.N.R. MARWALI ET AL), 30 October 2008 (30.10.2008), abstract --	1-15
A	EP 1469585 A1 (EMERSON NETWORK POWER CO., LTD.), 20 October 2004 (20.10.2004), abstract -- -----	1-15

International patent classification (IPC)

H02M 1/44 (2007.01)
H02M 7/493 (2007.01)
H02M 7/17 (2006.01)
H02M 7/23 (2006.01)
H02M 7/77 (2006.01)
H02M 7/81 (2006.01)

Download your patent documents at www.prv.se

The cited patent documents can be downloaded:

- From "Cited documents" found under our online services at www.prv.se (English version)
- From "Anförda dokument" found under "e-tjänster" at www.prv.se (Swedish version)

Use the application number as username. The password is **SERSTAVTMZ**.

Paper copies can be ordered at a cost of 50 SEK per copy from PRV InterPat (telephone number 08-782 28 85).

Cited literature, if any, will be enclosed in paper form.

INTERNATIONAL SEARCH REPORT
Information on patent family members

International application No.
PCT/SE2009/050844

EP	1983641	A2	22/10/2008	US	7564703 B	21/07/2009

US	6118680	A	12/09/2000	NONE		

EP	1575156	A2	14/09/2005	US	7327588 B	05/02/2008
				US	20050179419 A	18/08/2005

US	5257180	A	26/10/1993	CA	2066490 A,C	14/10/1997
				DE	69217109 D,T	05/06/1997
				EP	0510601 A,B	29/01/1997
				KR	960000802 B	12/01/1996

US	20080265680	A1	30/10/2008	NONE		

EP	1469585	A1	20/10/2004	AU	2002357570 A	24/07/2003
				CN	1215636 C	17/08/2005
				CN	1430324 A	16/07/2003
				US	7038923 B	02/05/2006
				US	20050041445 A	24/02/2005
				WO	03058802 A	17/07/2003
