

(19) World Intellectual Property Organization
International Bureau



(43) International Publication Date
28 February 2002 (28.02.2002)

PCT

(10) International Publication Number
WO 02/16233 A1

(51) International Patent Classification⁷: B65G 1/127,
G07F 7/06

[GB/GB]; 12 South Broomage Avenue, Larbert, Stirlingshire FK5 3LF (GB). PIGGOTT, Trevor [GB/GB]; The Old School House, Leighton Buzzard LU7 9DP (GB).

(21) International Application Number: PCT/GB01/03698

(74) Agent: SAUNDERS & DOLLEYMORE; 9 Rickmansworth Road, Watford, Hertfordshire WD18 0JU (GB).

(22) International Filing Date: 17 August 2001 (17.08.2001)

(25) Filing Language: English

(81) Designated States (national): AE, AG, AL, AM, AT, AU, AZ, BA, BB, BG, BR, BY, BZ, CA, CH, CN, CO, CR, CU, CZ, DE, DK, DM, DZ, EC, EE, ES, FI, GB, GD, GE, GH, GM, HR, HU, ID, IL, IN, IS, JP, KE, KG, KP, KR, KZ, LC, LK, LR, LS, LT, LU, LV, MA, MD, MG, MK, MN, MW, MX, MZ, NO, NZ, PH, PL, PT, RO, RU, SD, SE, SG, SI, SK, SL, TJ, TM, TR, TT, TZ, UA, UG, US, UZ, VN, YU, ZA, ZW.

(26) Publication Language: English

(30) Priority Data:
0020241.6 17 August 2000 (17.08.2000) GB

(71) Applicant (for all designated States except US): PICKUPWORKS LIMITED [GB/GB]; 20/22 Borough Road, North Shields, Tyne & Wear NE29 6JZ (GB).

(84) Designated States (regional): ARIPO patent (GH, GM, KE, LS, MW, MZ, SD, SL, SZ, TZ, UG, ZW), Eurasian patent (AM, AZ, BY, KG, KZ, MD, RU, TJ, TM), European patent (AT, BE, CH, CY, DE, DK, ES, FI, FR, GB, GR, IE,

(72) Inventors; and

(75) Inventors/Applicants (for US only): FAIR, Robert

[Continued on next page]

(54) Title: APPARATUS AND METHOD FOR THE EXCHANGE OF ITEMS WITH LIMITED ACCESS

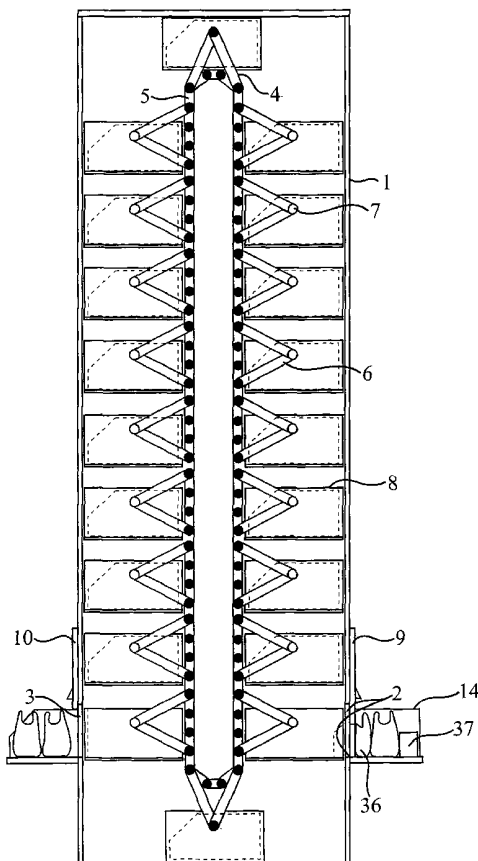

(57) Abstract: Apparatus for the exchange of goods, comprising an enclosure having means for storing a plurality of containers internally, means for moving a container to an access means where a container can be loaded and/or unloaded, wherein the container is only able to be accessed for unloading when a user performs a specified security operation, including the step of identifying himself or his authority to unload a specified container.



WO 02/16233 A1



IT, LU, MC, NL, PT, SE, TR), OAPI patent (BF, BJ, CF, CG, CI, CM, GA, GN, GQ, GW, ML, MR, NE, SN, TD, TG).

For two-letter codes and other abbreviations, refer to the "Guidance Notes on Codes and Abbreviations" appearing at the beginning of each regular issue of the PCT Gazette.

Published:

— *with international search report*

EXCHANGE OF ITEMS

This invention relates to exchange of items. In particular, it relates to the exchange of merchandise between a supplier and a customer.

5

It is often desirable that, in addition to a normal process by which a customer attends a store, collects a series of items, pays for them and carries them away with him, a store also provides a service in which the customer may order, by telephone or over the Internet for example, a number of goods and the store
10 then collects these goods from their shelves or storage and then supplies them to the customer. Typically, the supply may be by delivery.

However, delivery can be costly because of the ever increasing cost of fuel and transportation and is also inconvenient because the customer must be present
15 to receive delivery. A delivery time slot must be agreed and the delivery may be delayed due to road conditions or other reasons, which can be unsatisfactory. There are other problems such as a possible lack of suitable parking space at the delivery point and the fact that unavailability of stock may lead to a customer not obtaining the complete order he is expecting to obtain. Once the delivery is made,
20 there is little that the store can do at the time of delivery to correct this sort of circumstance.

Alternatively, a merchandiser can collect a bundle of goods as before and keep them on their premises for collection by the user. This approach, however,
25 requires the user to attend the merchandiser's store whilst that store is open for business and valuable storage space can be taken up.

In another situation, a parcel delivery service, or the like, may have to make several attempts at delivering a package to a particular address if the
30 intended recipient is not present to sign for receipt. This occupies valuable time of the delivery service operative, and is therefore an expense to the delivery

- 2 -

company. Alternatively, the delivery service operative may leave a calling card at the addressee's premises that indicates a collection address where the intended recipient can collect his or her package. However, the collection address may be remote from the recipient's premises, and may only be open for collections at
5 inconvenient times.

The present invention arose in an attempt to provide an improved method of exchanging items between merchandisers and customers.

10 According to the present invention there is provided apparatus for the exchange of goods, comprising an enclosure having means for storing a plurality of containers internally, means for moving a container to an access means where a container can be loaded and/or unloaded, wherein the container is only able to be accessed for unloading when a user performs a specified security operation,
15 including the step of identifying himself or his authority to unload a specified container.

In some embodiments two access means are provided at different parts of the enclosure, a first one of these being operable by a supplier of the merchandise
20 to insert containers into the enclosure, or to load containers within the enclosure, and a second access means being operable by a customer to obtain access to a previously stored or loaded container.

Alternatively, a single access means can be provided; the containers being
25 loaded into, and removed from, the one access point.

Preferably, the access means comprises a conveyer system for moving a plurality of containers within the enclosure and means for moving selected ones of the containers to the/or each access means when required.

30

- 3 -

The security operation may comprise the customer inputting a security number, or inputting an identification device, such as a credit card, smart card or other personal identification device and the apparatus is operable, upon an identification device being correctly presented, to present a container which has
5 previously associated with that identity, to the access means for access by that customer.

Preferably, the access means comprises a door having an electronic lock.

10 According to the present invention there is provided an apparatus for the exchange of goods comprising: an enclosure including a movable receptacle compartmentalisable by the insertion of one or more removable divider; means for moving the receptacle to a loading or an unloading point; wherein, the receptacle and a door located at the loading or unloading point can be brought into a relative
15 position that only facilitates access to a specified receptacle or to a specified compartment located therein.

According to the present invention there is provided an apparatus for the exchange of goods comprising: a plurality of receptacles, disposed within an
20 enclosure, linked to form a paternoster that is adapted to transport the receptacles between a loading point and an unloading point; wherein a plurality of access doors are provided at the loading point and the unloading point that are integral to and distributed along a larger maintenance door that facilitates direct access to the paternoster located within the enclosure.

25

Embodiments of the present invention will now be described, by way of example only, with reference to the accompanying schematic drawings, in which:

Figure 1 shows a storage enclosure;

30

Figure 2 shows a container;

- 4 -

- Figure 3 shows a container for storing items at other than ambient temperature;
- 5 Figure 4 shows a door arrangement of the secure enclosure;
- Figure 5 shows a door locking arrangement;
- Figure 6 shows a door arrangement with a door in a semi-raised position;
- 10 Figure 7 shows a door arrangement with a door in a semi-lowered position;
- Figure 8 shows a door arrangement;
- 15 Figure 9 shows a door in the same arrangement as Figure 8 with a receptacle in a lowered position;
- Figure 10 shows an alternative receptacle configuration;
- 20 Figure 11 is a detail of the access point of the apparatus showing several doors arranged on a larger maintenance door;
- Figure 12 is a detail of the access point of the apparatus with the
- 25 maintenance door removed;
- Figure 13 shows a transportable apparatus; and
- Figure 14 is a detail of the access point of the apparatus showing the
- 30 maintenance door in an open position.

- 5 -

Referring to Figure 1 a storage and retrieval system for assembled items of merchandise comprises a secure enclosure 1 which is preferably provided with two openings 2 and 3. However, more or less openings than this may of course be provided (see Figures 11 to 13). Preferably, the enclosure is mounted such that
5 one of the openings 2 is accessible from inside a store or other merchandising premises and the other opening 3 is accessible from externally of the premises. Thus the enclosure may be placed against the outside wall of a premises, perhaps with a hole knocked through the premises wall in line with opening 2. Alternatively, the enclosure may be built into the structure of the premises or
10 access may be obtained through an existing doorway, window way, vent or other opening in the premises.

The enclosure is formed of a material suitable for the intended environment such as a metal or weather resistant plastics material for example.
15 The enclosure is provided with a means for receiving and storing a number of collections of merchandise via opening 2 and for presenting a selected one of these to opening 3. In the examples shown, this comprises a vertical conveying machine chain 4 which comprises two spaced apart endless chains 5 arranged to synchronously move up and down in a guided vertical direction (under the control
20 of a motor for example) and around a pair of toothed wheels (not shown). Attached at regular intervals to the chains are a number of pairs of triangular shaped links 6. The triangular links are provided on either side of the apparatus, attached to each chain and they are pivotally connected, at apices 7 to a vertical side members of receptacles 8, which each have a base and side panels and are
25 open at their front and rear. In the figure the apices of the triangular members are shown as being pivotally connected about two thirds the way up each side panel of each receptacle 8. In practice they may not necessarily be so positioned and may be positioned at any suitable position. It has been found desirable to mount
30 the combination of chain, links and receptacles may be referred to as a 'paternoster' for simplicity.

- 6 -

Each receptacle is open at both ends to enable it to receive containers via one end and to subsequently dispense them via the other end. The receptacles are held so that they can pivot. As shown, under the effects of gravity, as each
5 receptacle moves with the chain, as it passes over the top it pivots relative to the chain such that the end which was distal to the chain becomes proximal and the proximal end becomes distal. Receptacles may be subdivided into compartments by the deployment of one or more removable dividers 19 (e.g. as shown in Figures 6 and 7). These dividers can be inserted in a horizontal or vertical orientation, and
10 the receptacles are adapted to receive them. By using two or more spaced-apart dividers, a receptacle can be divided into three or more compartments.

The openings in the enclosure are preferably in the form of doorways and vertically sliding doors, 9, 10 may be provided which can be slid vertically to
15 open a doorway to allow the entry of a container into a receptacle (or the removal of a container for a receptacle) and then vertically slid downwards to closed position.

Figure 2 shows a typical container 11 having a base 12, two side walls 13, 14, rear wall 15 and lowered front wall 16. Front wall 15 is preferably lower than
20 the rear wall 15 to enable easier loading and unloading but this is not essential. The front and rear walls are provided with gripping holes 17, 18 for enabling manipulation of the receptacle, which is in itself shaped and sized to be able to fit into the receptacles 8 attached to the chain mechanism in the storage enclosure 1.

25

Note that in the secure enclosure 1, the openings 2 and 3 are preferably aligned so that when a receptacle is positioned adjacent to the first opening 2 another receptacle aligns with the second opening 3 to the second door opening.

30

The panel door 10 over the opening through which merchandise is

- 7 -

retrieved and, optionally, also the door 9 through which merchandise is placed into the enclosure, are preferably provided with secure locking means such as electronic locks. They may be preferably associated with means such as credit card or smart card readers or keypads, to enable identification of an authorised person before they can be opened. Other means such as fingerprint or retina scans may be used.

Referring to Figure 4; each opening is provided with a generally rectangular panel door such as door 10 shown in Figure 4. This is retained in vertical parallel guides 20 situated adjacent to vertical sides of the opening 3 so that when the door is moving it is guided in a generally vertical direction. In one movement mechanism, attached to the door 10 by an anchorage 23 is one end of a flexible rope or chain 24 which passes over a number of suitably shaped wheels 25 each of which freely rotatable about a central pivot. The other end of the rope or chain is positively attached to a counter weight 26 which is chosen to approximately equal the weight of the panel door. By using this counter weight only a small upward force need be applied to the panel door in order to move the door to an open position and to remain open, whereby the available opening is sufficient to enable withdrawal of a receptacle 14. Note that preferably, each receptacle 14 includes, at its rear end 15 a raised lip portion 27 which is sufficiently high to abut the door when the door is in its highest position. This then prevents the receptacle from being withdrawn entirely and inadvertently or otherwise removed by the customer. The customer must pull out the receptacle and remove items loaded within it and then pushes the receptacle back in order to be able to close the doors.

Note that instead of the counter balance shown, many other methods of balancing the door may be used, such as spring means, or by dividing the panel into about the horizontal access and using the lower section to counter balance the

- 8 -

upper section. Alternatively, the counter weight 26 may be replaced by powered means or the panel may be hinged about one of its sides. Other opening methods may be used.

5 The door panels include a handle portion 28 enabling lifting of the door. Alternatively, door opening and/or closing may be fully automatic, e.g. controlled by the processing system.

10 The door may be locked and unlocked by means of an electrically locking mechanism as is stated in Figure 5. The door, or a separate member attached to the door, is provided with a recess 30. A mechanical locking bolt or other means 31 engages into this recess, under the resilient force of a spring 32 and prevents movement of the door until an opening force is exerted on the locking member 31 by means of an electro-magnet 32. This causes the locking bolt 31 to retract away
15 from the recess and thereby to free the door for movement. This mechanism is shown as generally as 33 in Figure 4.

20 A known code reading device 34, which may be for example a smart card or credit card reader causes an electrical signal to be passed to a control device 35 which acts, upon a particular identification being read, to cause a known receptacle 8 to align with the door opening 3. Once the receptacle is aligned with the door opening, then the control apparatus 35 activates the electro-magnetic lock and enables the door to be opened, or the door may be opened automatically by means of a suitable drive mechanism.

25

Once any goods have been unloaded from the container 14, the door can be closed (manually or automatically) and the electronic lock is re-activated.

30 In the embodiments described, a selected receptacle is moved to a selected position relative to the opening, so that a door can be opened and goods removed from the receptacle. In a preferred embodiment the receptacles are divided into

- 9 -

sub-compartments by one or more dividers, as described above. This enables two or more separate sets of goods, e.g. different orders, perhaps for different customers, to be supplied from a single receptacle. However, it then becomes important that a customer can only retrieve his goods, not any other goods stored
5 in another compartment.

This is achieved, in embodiments of the invention, by adjusting the relative rest position of a receptacle and opening position of the door. This may be achieved by altering the rest position of the receptacle, so that when the door is
10 opened it only allows access to one compartment. Alternatively, the receptacle can always come to a fixed rest position and the door be selectably movable to an upper or lower 'open' position, each of which allows access to a particular compartment.

15 Figures 6 and 7 show the door 10 in reciprocal positions; in Figure 6 the door 10 is in a semi-raised position to only allow access to the lower compartment 43 of the selected receptacle 8, and in Figure 7 the door is in a semi-lowered state to only allow access to the upper compartment 44 of the receptacle 8. The control electronics can be used to determine which position the door is to open to,
20 dependent on the particular compartment to be accessed.

Alternatively, instead of the door 10 being moved relative to the receptacle 8, the selected receptacle can be moved to a rest position relative to the door position as shown in Figures 8 and 9. Here, the door 10 is in a semi-raised
25 position, and the receptacle is moved from a position where only the lower compartment 43 is accessible (Figure 8) to a position where only the upper compartment 44 is accessible (Figure 9). Again, the control electronics can determine the exact rest position (upper or lower) of the receptacle, depending on the particular compartment to be accessed.

30

- 10 -

Note that the number of compartments in a receptacle is not restricted to two, but can in fact be any number depending upon a given situation. By way of an example, Figure 10 shows a receptacle 45 that includes three compartments. This will require three separate rest positions, or three separate door opening
5 positions, and so on.

In other embodiments of the apparatus, the enclosure 1 will include more than one 'paternoster', with each paternoster operating in parallel (or independently) with adjacent paternosters. Alternatively, one or more
10 paternosters may be employed that are orientated in an horizontal plane as opposed to the vertically orientated paternoster shown in Figure 1.

The means by which the stored goods are moved to the loading/unloading door or doors in the horizontal arrangement, may not necessarily be via a
15 paternoster type mechanism. An alternative means of conveying the load, for example by a travelling table on rails accessing a bank of storage racks, may be employed. In particular, this mechanism may be housed in a portable horizontal enclosure such as a standard freight container.

In embodiments with more than one paternoster, there will be additional
20 doors associated with each paternoster. Figures 11 and 11A depict a detail of the apparatus in an embodiment where four paternosters are employed. Here, there are four separate doors 10 to 10c, each allowing access to respective paternoster receptacles located behind the doors. The Figures also show a larger maintenance
25 door 50; in Figure 11 the maintenance door is in a closed position, and in Figure 11A the maintenance door is shown in a partially open position.

Each access door 10 to 10c is located on and operates within the larger
30 maintenance door 50. Advantageously, this maintenance door allows easy access to the internal workings of each paternoster within the enclosure of the apparatus, and facilitates expedited maintenance of the apparatus.

- 11 -

In certain situations it is desirable for the apparatus to be easily transportable. This can be achieved in a number of ways. One way is exemplified in Figure 13 where the apparatus forms part of trailer 60 that can be readily attached to a motorized cab. The door 10 is shown in a lateral wall of the enclosure, but it could equally be located at the rear of the trailer in a position indicated by 61. Alternatively, the entire apparatus may be motorized or be placed in a standard size freight container that can be transported in any of the known ways. Note that the internal paternoster arrangement housed within the trailer 60 is orientated in the horizontal plane.

Use of the apparatus will now be described.

A customer contacts the merchandiser in any appropriate way, generally by telephone or using the Internet, and places an order for a number of goods. The merchandiser takes details of the customer, or if an existing customer, retrieves these details from a database, and takes payment details, such as a credit card number and other security details, from the customer. The normal procedures in Internet shopping can be used and will be apparent to the skilled reader.

The merchandiser then sends a member of its staff to collect the various items on the order from either shop shelves or from a warehouse or from other locations. Once these have all been collected, they may be placed into first storage containers such as carrier bags, or boxes, as shown schematically by 36 and 37 in Figure 1. The merchandiser then places these into one of the containers 14 (Figure 2) and places this into the storage enclosure 1. Preferably each individual receptacle 8 within the storage enclosure has unique identification, such as a unique identity number and the merchandiser programmes into the apparatus the identity number of the receptacle in which he has placed a particular collection of goods, together with the identity of the customer, or an identity

- 12 -

number of that order. Upon closing door 9, the receptacle bearing the goods is moved to a suitable storage region within the enclosure.

Subsequently, the customer attends the enclosure, which, it will be recalled can be attended at any time and enters identification details into the identification verification unit 34. This preferably comprises the action of inserting his credit card, smart card or other identity means into the card reader 34 or may be by entering a code by a keypad, or otherwise, to verify the identity or authority of the customer. A combination of actions may be required, e.g. card-reading and entry of a PIN. Upon the verification being successful, the chain-linked receptacles are moved so that the relevant one of the receptacles is moved adjacent to opening 3. Where the receptacle is a multi-compartmented one, the receptacle is moved to the appropriate one of a plurality of 'rest' or 'access' positions. Door 10 is then unlocked and the customer may open the door, as described above, and retrieve his articles from the apparatus. After unloading, he pushes the container 14 back into the apparatus and closes the door. Alternatively, the container 14 can be mounted on runners, or other suitable means may be provided, whereby the container can be automatically retracted into the apparatus after a defined period for example so that if a user inadvertently forgets to push to retract the container it is automatically retracted after a while.

Sometimes, after a customer places an order the merchandiser will find that one or more of the goods are not in stock or that he cannot supply an item for any number of reasons. In variations of the invention, the customer initially gives details of his credit card and his credit card is debited with the projected cost of the order. Upon the merchandiser being unable to supply some items, he can enter this information via control apparatus such as reader 34 so that when a customer subsequently attends and inserts his credit card, his credit card account can then be automatically credited with the required amount.

30

- 13 -

If a customer's order contains some items which have to be stored at a temperature other than an ambient temperature, such as chilled or frozen items for example, then an insulated container 40, such as shown in Figure 3 may be used. This has sides, base and hinged lid of a material, such as foamed polystyrene or
5 plastics material, which is suitable for insulation so as to keep items inside at the desired temperature for as long as possible. This may also be provided with an extension lip 41 to prevent the container's removal from the storage system.

10 Instead of a credit card, other tokens, such as intelligent tokens (smart cards), identity cards, etc, may be used which may store data electronically, magnetically, optically or otherwise.

In alternative embodiments, an apparatus is used by a plurality of suppliers, to supply goods to customers, rather than by a single merchandiser.
15

CLAIMS

1. Apparatus for the exchange of goods comprising: an enclosure including a movable receptacle compartmentalisable by the insertion of one or more
5 removable divider; means for moving the receptacle to a loading or an unloading point; wherein, the receptacle and access means located at the loading and/or unloading point can be brought into a relative position that only facilitates access to a specified receptacle or to a specified compartment located therein when a user performs a specified security operation.
- 10
2. Apparatus as claimed in Claim 1, wherein two separated access means are provided; a first access means through which a receptacle or compartment can be loaded, and a second access means through which a receptacle or compartment can be unloaded.
- 15
3. Apparatus as claimed in Claim 1 or Claim 2, wherein at least one access means comprises an opening door which is lockable in a closed position.
4. Apparatus as claimed in Claim 3, wherein the door is lockable by an
20 electrically controlled lock.
5. Apparatus as claimed in any preceding claim, comprising means for causing a specified receptacle to move to an access means, and for unlocking a door at said access means to access said specified receptacle or compartment
25 therein, upon a user performing the specified security operation.
6. Apparatus as claimed in Claim 5, wherein the security operation includes the step of identifying himself or his authority to unload a specified receptacle or compartment.

- 15 -

7. Apparatus as claimed in Claim 5 or 6, wherein the security operation comprises causing an identity card, credit card or intelligent token identifying the user to be read, and verifying that the user is correctly identified by at least partially using data stored on the token or card.
- 5
8. Apparatus as claimed in any preceding claim, comprising a conveyor mechanism for moving and storing containers within the enclosure.
9. Apparatus as claimed in Claim 8, comprising at least two synchronously moving vertically guided chains to which a plurality of load carrying receptacles are pivotally attached.
- 10
10. Apparatus as claimed in any preceding claim, wherein containers are used to house assembled merchandise, said containers being shaped to be loaded into and out of the receptacles, each container being provided with means preventing complete withdrawal of the container from one of the access means.
- 15
11. Apparatus as claimed in Claim 10, wherein the withdrawal prevention means comprises a lip.
- 20
12. Apparatus as claimed in Claim 10 or Claim 11, wherein the container is completely removable, when aligned in a particular direction, from one access means, but not from a second access means.
- 25
13. Apparatus as claimed in any of Claims 1 to 12, wherein the movable receptacle is movable to one or more discrete rest positions at the loading and unloading points that are relative to a fixed open position of the access means.
- 30
14. Apparatus as claimed in any of Claims 1 to 12, wherein the movable receptacle is movable to a fixed rest position and the access means is adapted to

- 16 -

have one or more discrete and selectable open positions that are relative to the fixed rest position of the receptacle.

15. Apparatus as claimed in any preceding Claim, wherein the movable
5 receptacle includes two or more compartments.

16. Apparatus as claimed any preceding Claim comprising: a plurality of
receptacles, disposed within an enclosure, linked to form a paternoster that is
adapted to transport the receptacles between a loading point and an unloading
10 point; wherein a plurality of access doors are provided at the loading point and the
unloading point that are integral to and distributed along a larger maintenance
door that facilitates direct access to the paternoster located within the enclosure.

17. Apparatus for the exchange of goods comprising: a plurality of
15 receptacles, disposed within an enclosure, linked to form a paternoster that is
adapted to transport the receptacles between a loading point and an unloading
point; wherein a plurality of access doors are provided at the loading point and the
unloading point that are integral to and distributed along a larger maintenance
door that facilitates direct access to the paternoster located within the enclosure.

20

18. Apparatus as claimed in any preceding claim, wherein the enclosure forms
part of a mobile apparatus, for example a trailer.

19. Apparatus as claimed in any of Claims 1 to 18, wherein the apparatus is
25 motorized.

20. A method of exchanging goods between a merchandiser and a customer,
wherein:

30 i) the customer places an order for a collection of goods from the
merchandiser;

- 17 -

- 5
- ii) the merchandiser collects said goods and loads the goods into an identifiable receptacle among a plurality of receptacles in a secure enclosure, the receptacles being movable within the enclosure;
 - iii) the customer subsequently attends the enclosure and performs a security operation which causes, if successful, said receptacle to be brought into a position adjacent to an access and any door or other means blocking said access to be unlocked;
 - iv) the customer withdraws the collection of goods from the receptacle.

10

21. A method as claimed in Claim 20, wherein the merchandiser loads a receptacle from a first access opening and the customer unloads from a second access opening, each receptacle being movable between the openings and to at least one position where it cannot be accessed from either opening.

15

22. A method as claimed in Claim 20 or Claim 21, wherein the receptacles are mounted on a conveyor mechanism for moving them within the enclosure.

20

23. A method as claimed in any of Claims 20 to 22, wherein the conveyor mechanism includes at least two synchronously moving vertical chains to which a plurality of load carrying receptacles are pivotally attached.

25

24. A method as claimed in any of Claims 20 to 23, wherein the or each receptacle is divided into at least two compartments by a divider.

30

25. A method of deposit and retrieval of an item, wherein:
- i) an item intended for a recipient is placed into a compartment of a compartmental receptacle among a plurality of receptacles in a secure enclosure, the receptacles being movable within the enclosure;

- 18 -

- iii) the intended recipient subsequently attends the enclosure and performs a security operation which causes, if successful, said compartment to be brought into a position adjacent to a blocked access means; and
- 5 iv) unblocking the access means in such a manner that only the compartment containing the intended recipient's item is accessible for retrieval by the recipient.

26. A method as claimed in Claim 25, wherein the access means includes a
10 door adapted to be opened to a fixed open position, and the recipient's compartment is moved into relative alignment with the fixed open position so as to allow retrieval of the recipient's item in that compartment only.

27. A method as claimed in Claim 25, wherein the compartmental receptacle
15 is moved to a fixed rest position and the access means includes a door adapted to have one or more discrete open positions, each discrete open position corresponding to a respective compartment, thus allowing retrieval of the recipient's item from that compartment only.

20 28. A method as claimed in any of Claims 20 to 27, using a secure enclosure as claimed in any of Claims 1 to 19.

1/7

Fig. 1

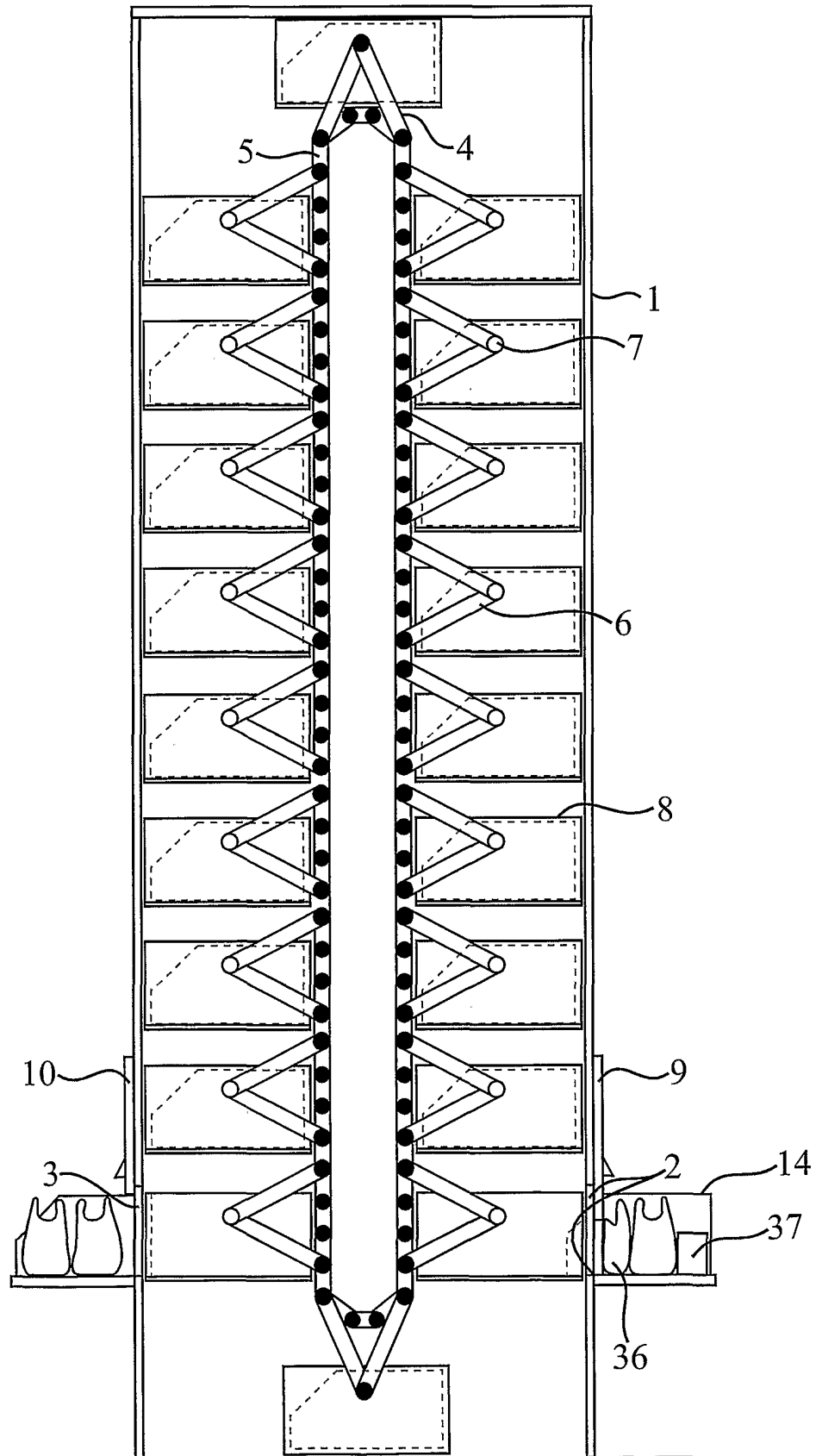

2/7

Fig. 2

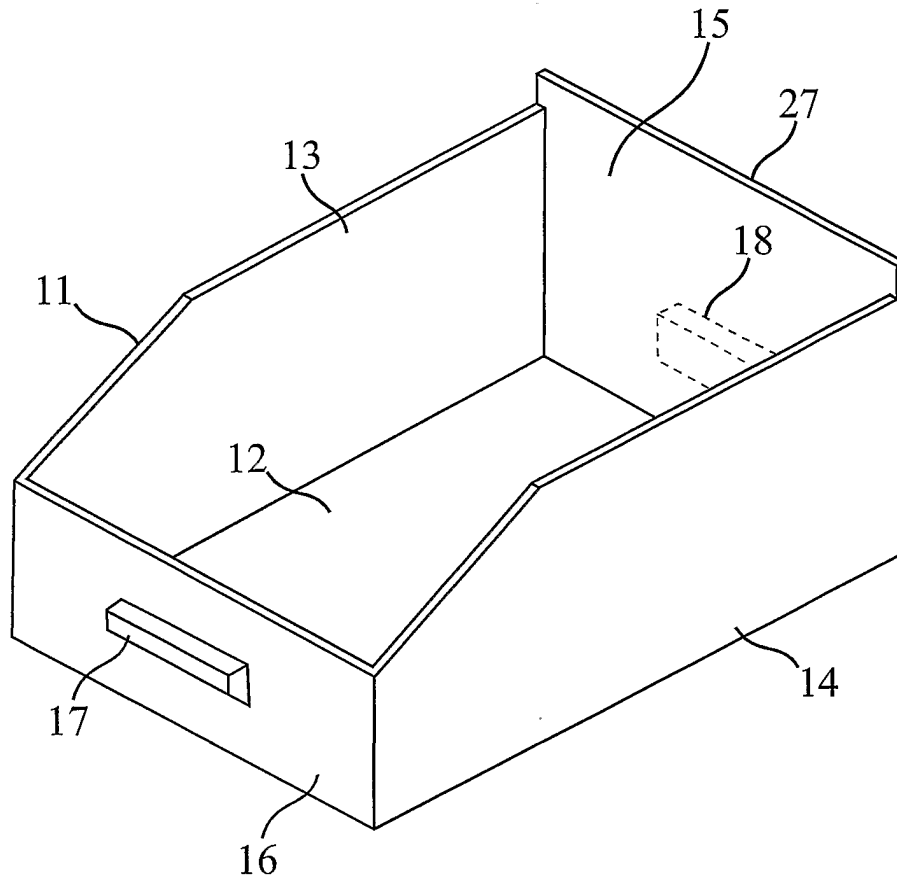

Fig. 3

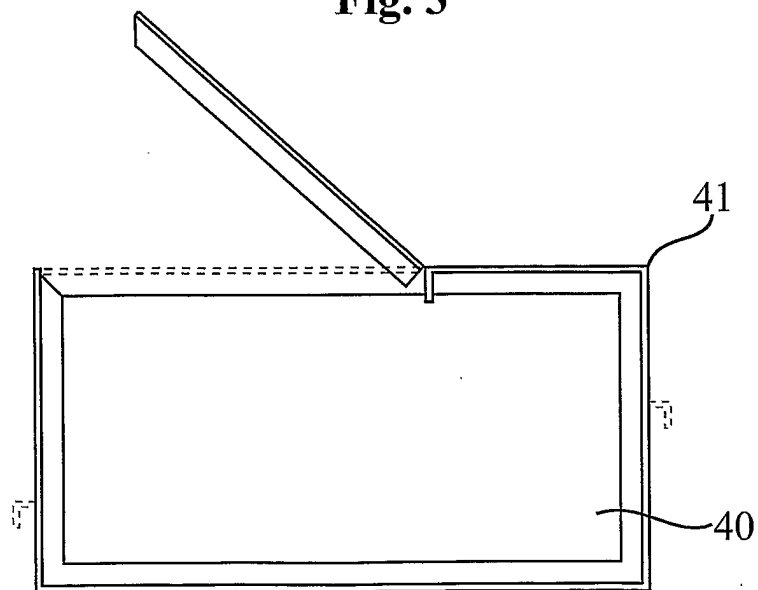

Fig. 4

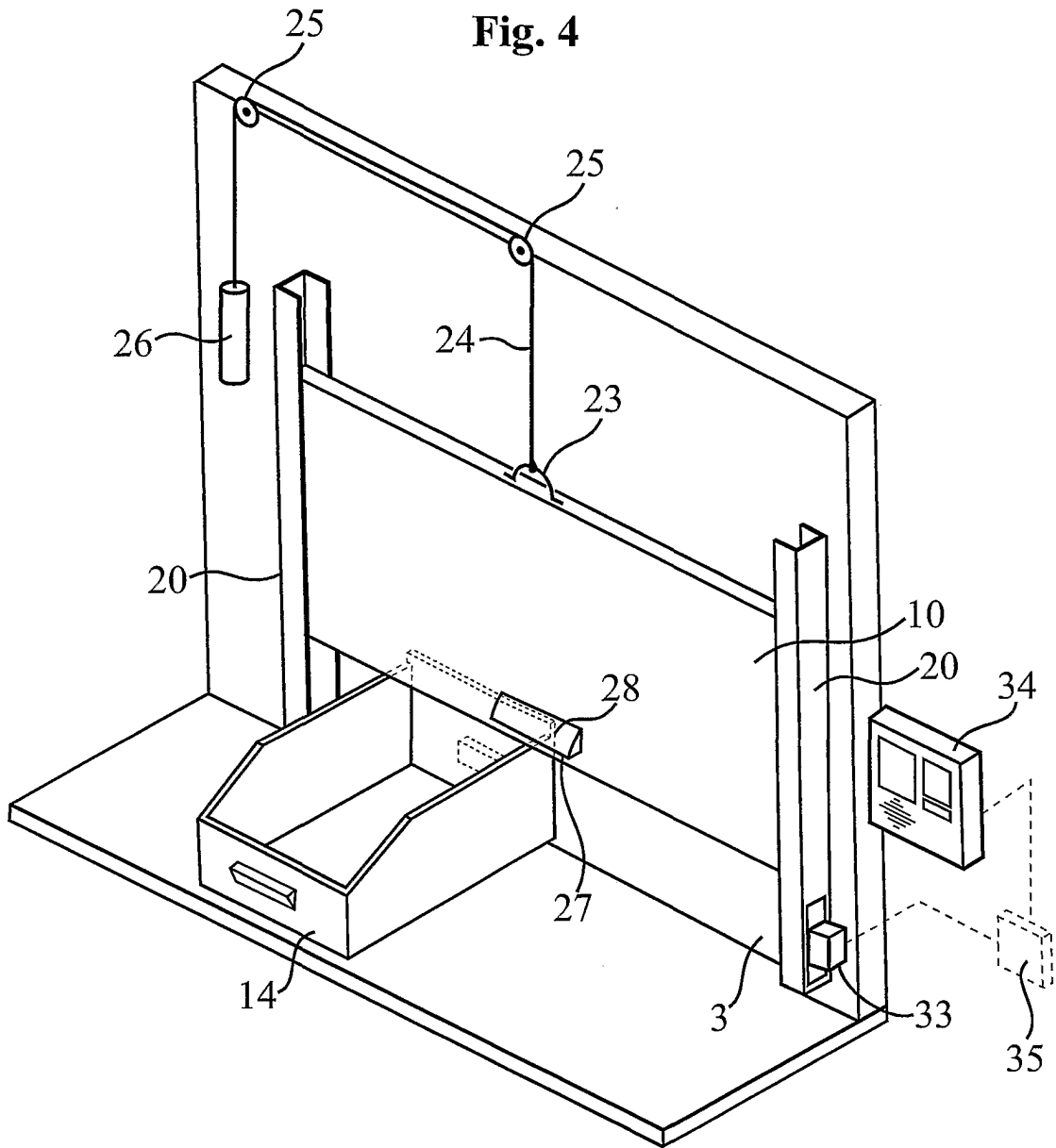

Fig. 5

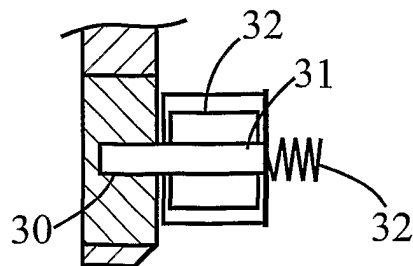

Fig. 7

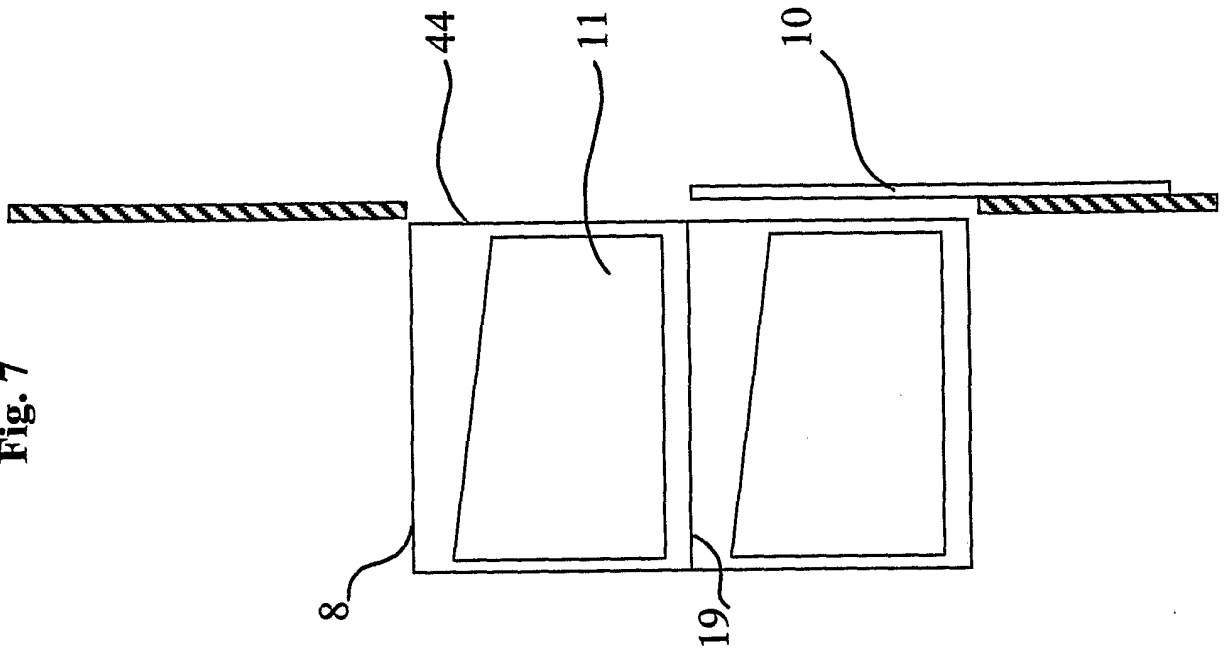
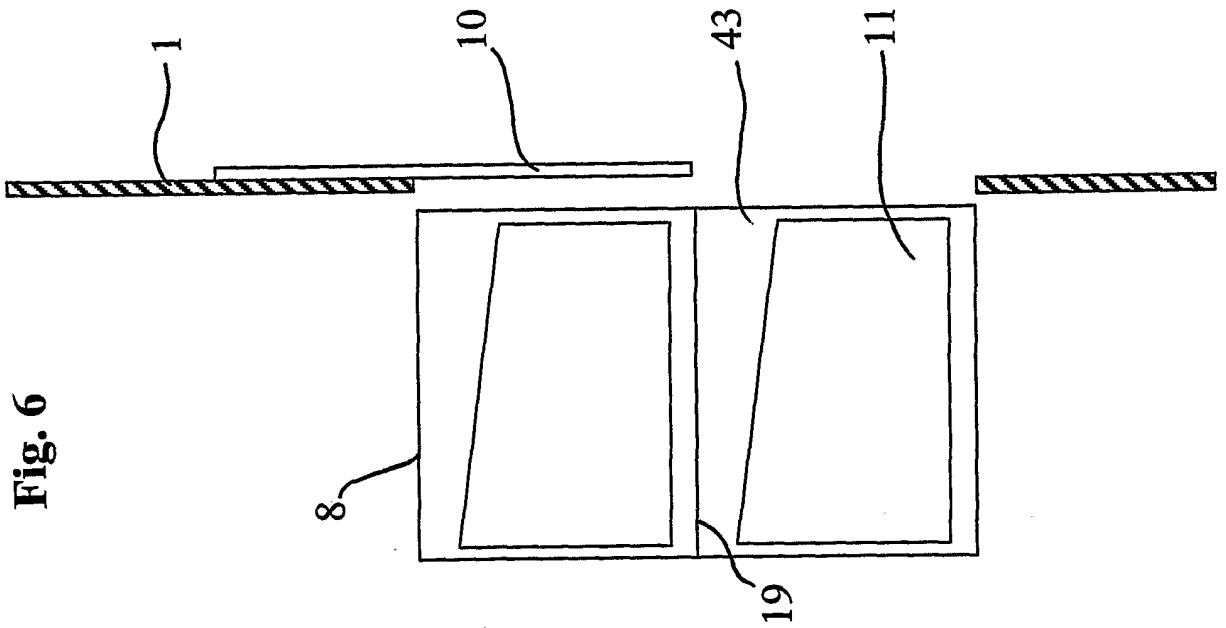
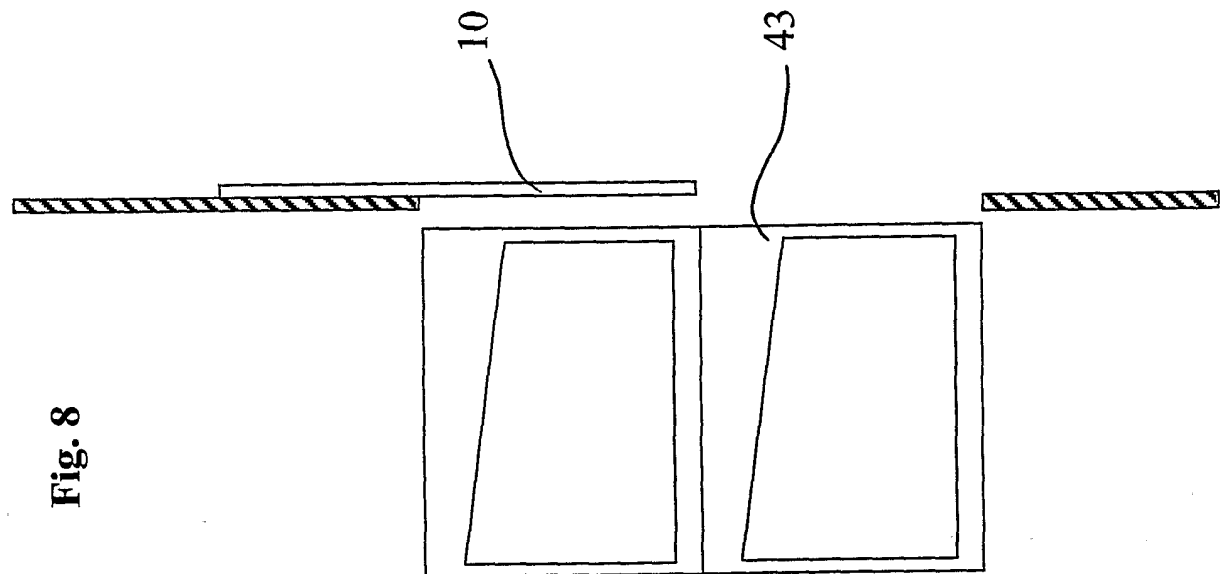
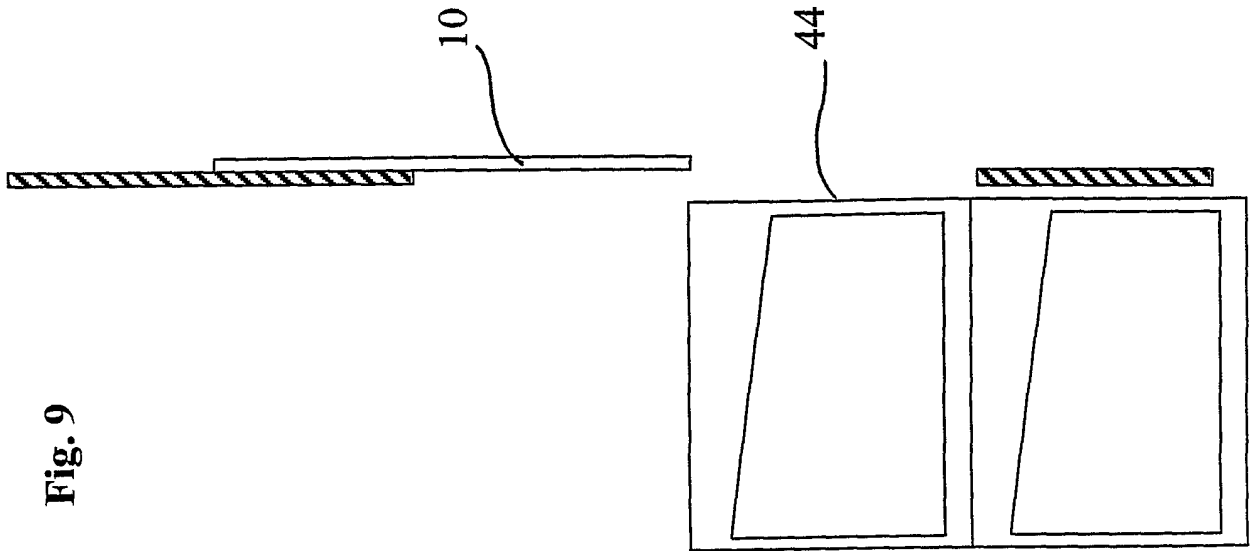

Fig. 6





6/7

Fig. 11

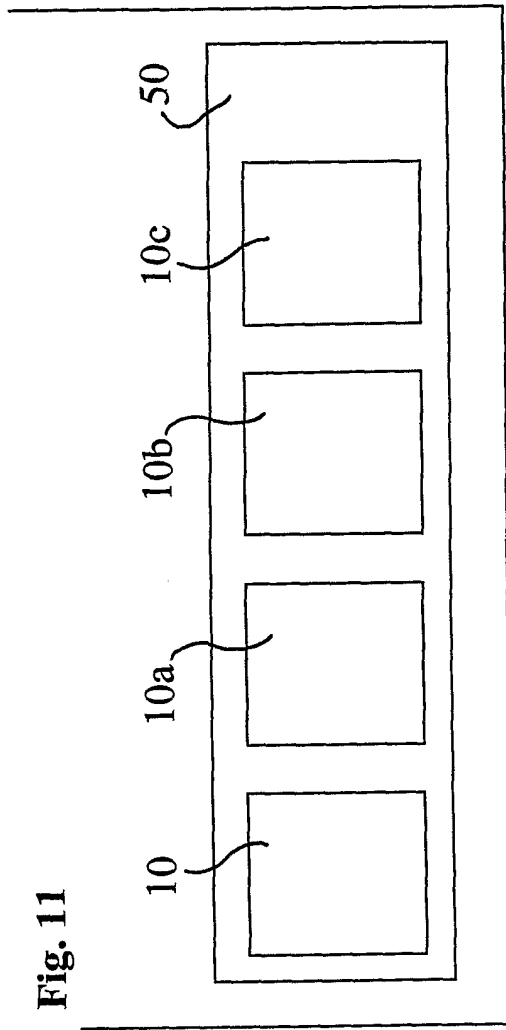

Fig. 12

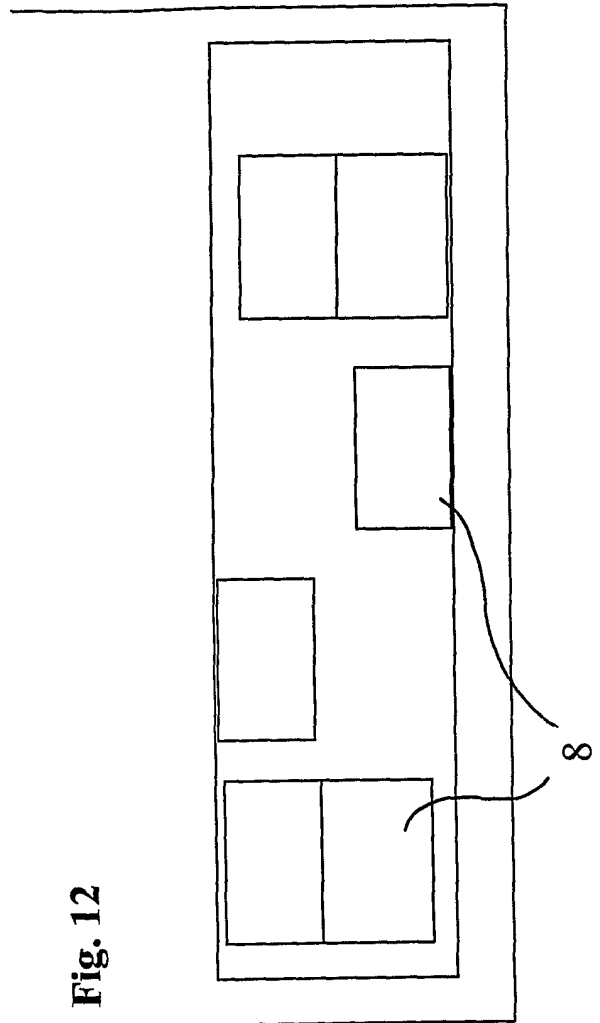
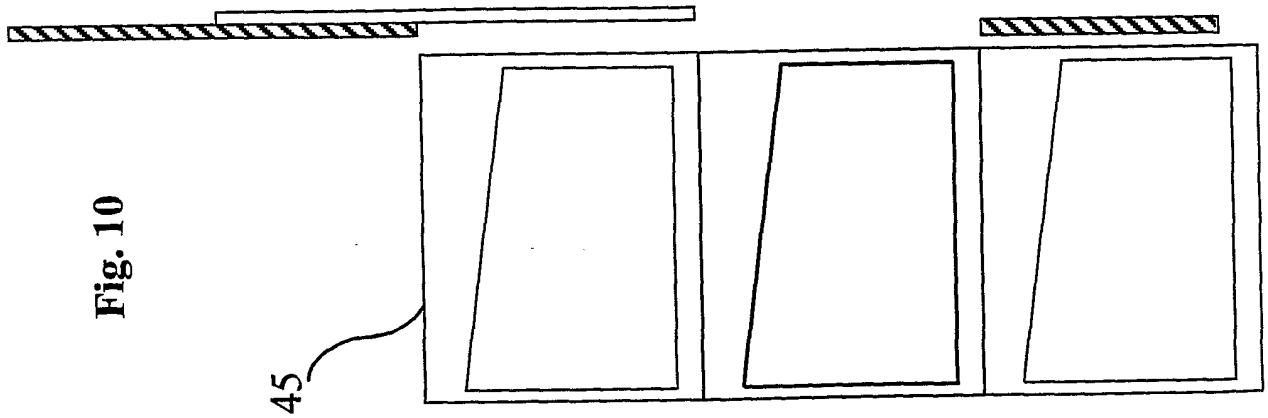

Fig. 10



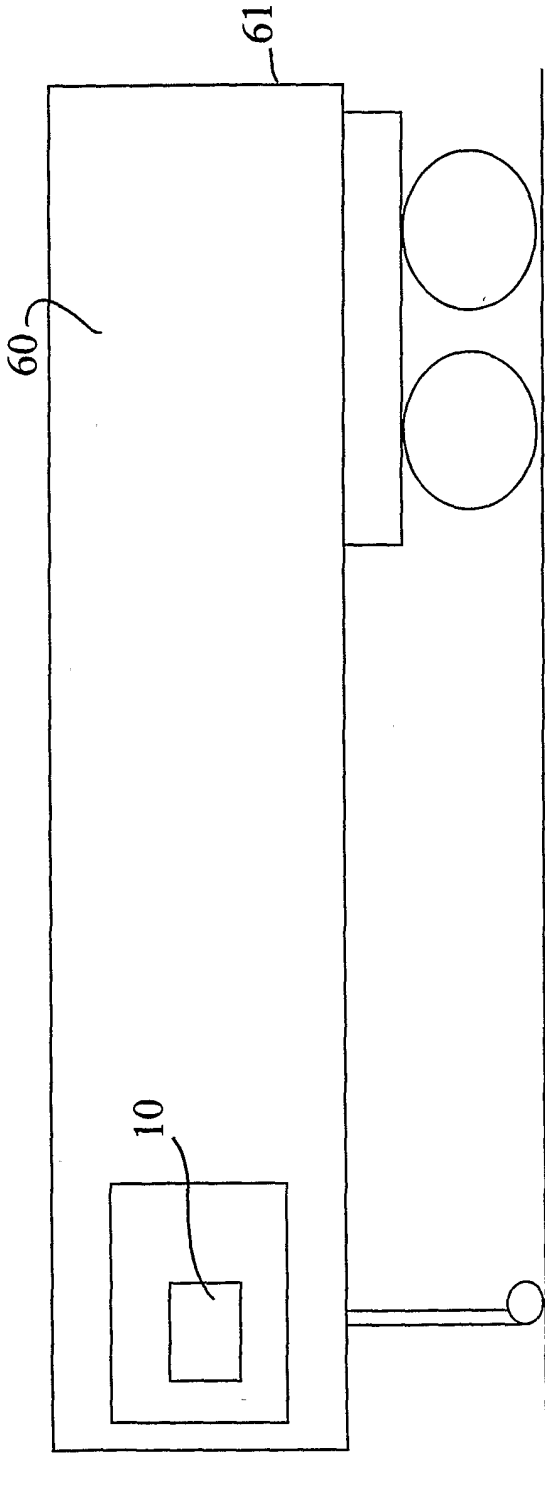

Fig. 13

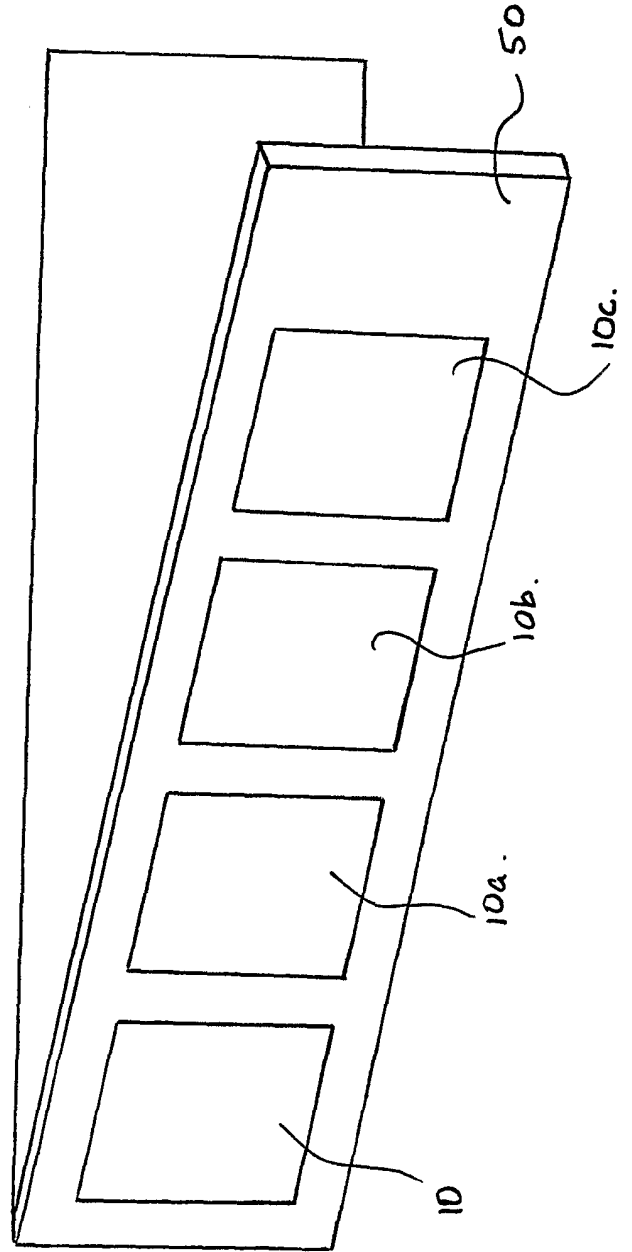

Fig. 14

INTERNATIONAL SEARCH REPORT

International Application No
PCT/GB 01/03698

A. CLASSIFICATION OF SUBJECT MATTER
IPC 7 B65G1/127 G07F7/06

According to International Patent Classification (IPC) or to both national classification and IPC

B. FIELDS SEARCHED
Minimum documentation searched (classification system followed by classification symbols)
IPC 7 B65G G07F A47B

Documentation searched other than minimum documentation to the extent that such documents are included in the fields searched

Electronic data base consulted during the international search (name of data base and, where practical, search terms used)

C. DOCUMENTS CONSIDERED TO BE RELEVANT

Category °	Citation of document, with indication, where appropriate, of the relevant passages	Relevant to claim No.
X	US 5 820 237 A (ROBEY) 13 October 1998 (1998-10-13) column 4, line 33 - line 40 column 5, line 16 - column 6, line 23; figures	1-9, 13-28
A	US 5 431 299 A (BREWER ET AL.) 11 July 1995 (1995-07-11) column 7, line 16 - line 19	18
A	DE 44 35 854 A (AHREND) 11 April 1996 (1996-04-11)	
A	US 4 650 264 A (DAHNERT) 17 March 1987 (1987-03-17)	

Further documents are listed in the continuation of box C. Patent family members are listed in annex.

- ° Special categories of cited documents :
- *A* document defining the general state of the art which is not considered to be of particular relevance
 - *E* earlier document but published on or after the international filing date
 - *L* document which may throw doubts on priority claim(s) or which is cited to establish the publication date of another citation or other special reason (as specified)
 - *O* document referring to an oral disclosure, use, exhibition or other means
 - *P* document published prior to the international filing date but later than the priority date claimed
 - *T* later document published after the international filing date or priority date and not in conflict with the application but cited to understand the principle or theory underlying the invention
 - *X* document of particular relevance; the claimed invention cannot be considered novel or cannot be considered to involve an inventive step when the document is taken alone
 - *Y* document of particular relevance; the claimed invention cannot be considered to involve an inventive step when the document is combined with one or more other such documents, such combination being obvious to a person skilled in the art.
 - *Z* document member of the same patent family

Date of the actual completion of the international search 24 October 2001	Date of mailing of the international search report 02/11/2001
--	--

Name and mailing address of the ISA European Patent Office, P.B. 5818 Patentlaan 2 NL - 2280 HV Rijswijk Tel. (+31-70) 340-2040, Tx. 31 651 epo nl, Fax: (+31-70) 340-3016	Authorized officer Deutsch, J.-P.
--	--

INTERNATIONAL SEARCH REPORT

Information on patent family members

International Application No

PCT/GB 01/03698

Patent document cited in search report	A	Publication date	Patent family member(s)	Publication date
US 5820237	A	13-10-1998	US 5902027 A US 5836662 A	11-05-1999 17-11-1998
US 5431299	A	11-07-1995	AU 1689295 A CA 2182081 A1 EP 0749617 A1 JP 10501143 T WO 9520804 A1	15-08-1995 03-08-1995 27-12-1996 03-02-1998 03-08-1995
DE 4435854	A	11-04-1996	DE 4435854 A1	11-04-1996
US 4650264	A	17-03-1987	NONE	