

H. W. Randle,

Cotton Press.

N^o 23,860.

Patented May 3, 1859.

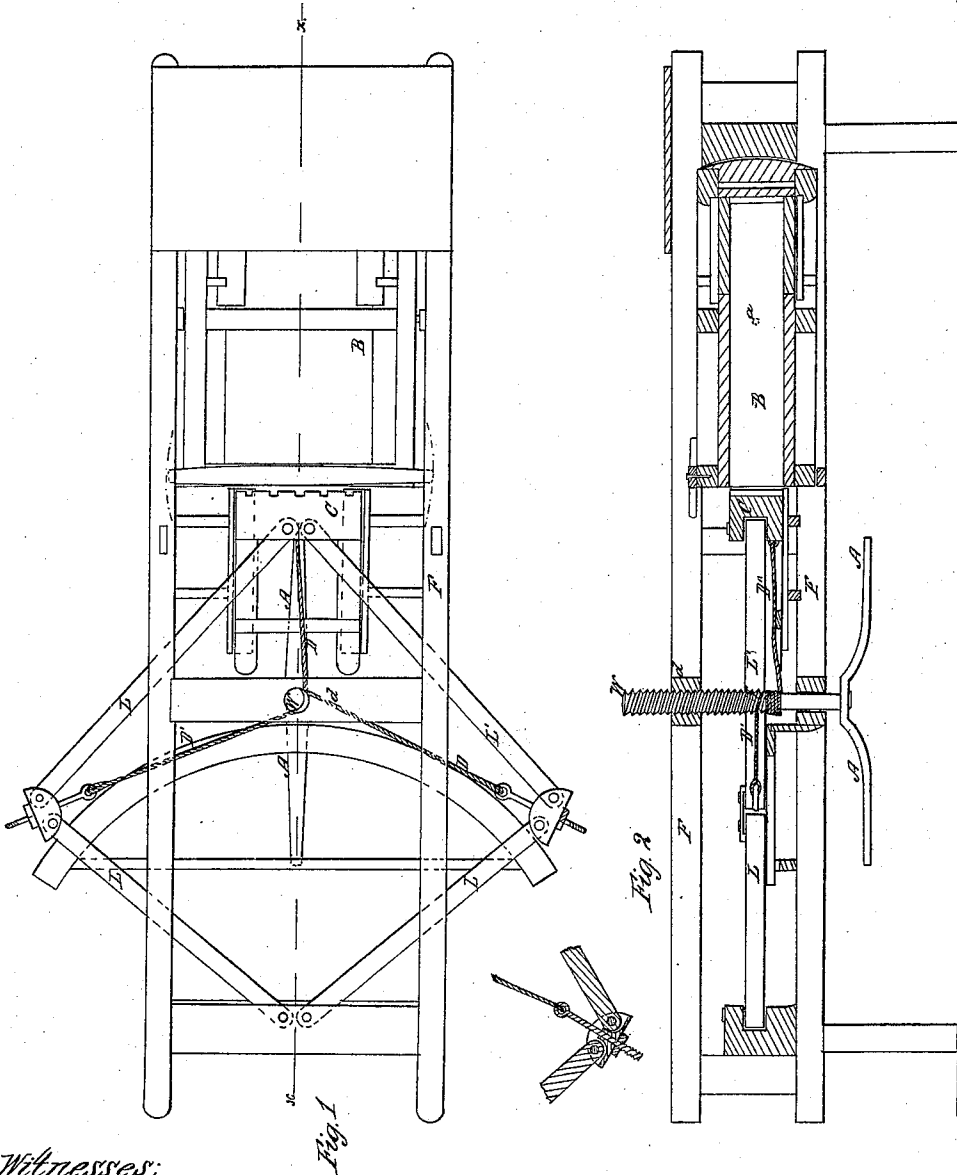

*Witnesses;
Geo. Patten
Geo. D. Selby*

*Inventor;
H. W. Randle*

UNITED STATES PATENT OFFICE.

H. W. RANDLE, OF BURNSVILLE, ALABAMA.

IMPROVEMENT IN COTTON-PRESSES.

Specification forming part of Letters Patent No. 23,860, dated May 3, 1859.

To all whom it may concern:

Be it known that I, H. W. RANDLE, of Burnsville, in the county of Dallas and State of Alabama, have invented a new and useful Improvement in Cotton-Presses; and I do hereby declare that the following is a full, clear, and exact description of the same, reference being had to the annexed drawings, forming part of this specification, in the several figures of which similar characters of reference denote the same part.

Figure 1 is a top view of the press. Fig. 2 is a vertical section on line *xx*.

My invention has reference to the manner of operating the toggle-levers which move the follower, the nature of the invention consisting in providing a vertically-moving windlass between the levers for the winding of the rope, drawing said levers together, so that the power exerted to operate the levers shall always act horizontally.

The details of construction and operation are as follows:

In the drawings, F is the frame, and B the cotton-box resting on trunnions *a*. C is the follower connected, as seen in Fig. 1, with the toggle-levers L L' in the usual manner.

To the angles of levers L and L' are attached the cords D D', as shown in Fig. 1, these cords leading to the windlass W, consisting of

a screw passing through a beam, *d*, of the frame. This screw has a double thread to receive the cord D D', and is of such size as to cause the shaft to descend the same amount as the cords wind upon it, so that the draft will never be oblique upon the levers.

The portion of the shaft W on which the cords wind may be plain, if desired, the upper portion being a screw to give the descent.

The animals are attached to the lever-arms A A below the frame.

A cord, D'', leads from the shaft W to the follower, so that the follower is withdrawn by reversing the movement. The cords D D' unwind by this operation and permit the separation of the two sets of levers.

I do not claim a spirally-grooved shaft without longitudinal motion for taking up the cord; but

I claim—

The vertical screw-shaft W, as described, in combination with the levers L L', cords D D' D'', and the follower, substantially as and for the purposes set forth.

In testimony whereof I have hereunto signed my name before two subscribing witnesses.

H. W. RANDLE.

Witnesses:

GEO. PATTEN,

JOHN S. HOLLINGSHEAD.