

Oct. 16, 1956

A. SALZBERGER
MOUNTING OF FRONT FEED DEVICE FOR BUSINESS
WRITING MACHINES
Filed Aug. 17, 1953

2,766,867

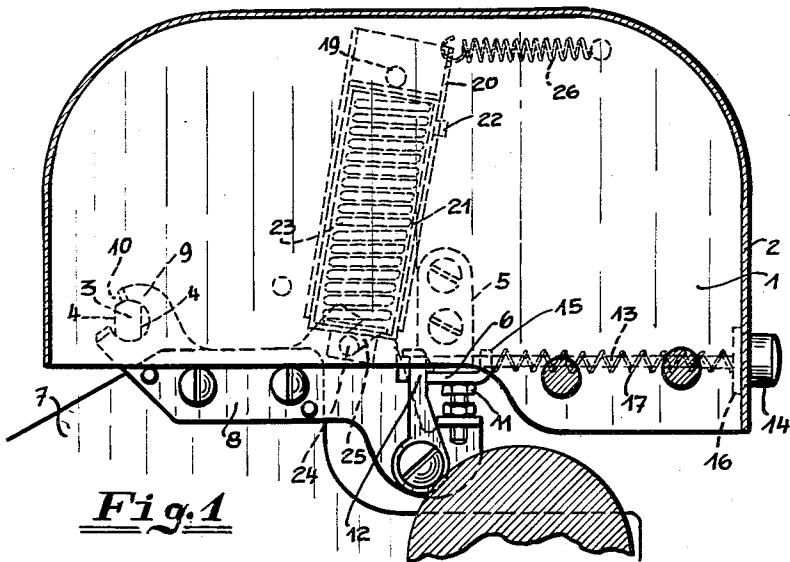

Fig. 1

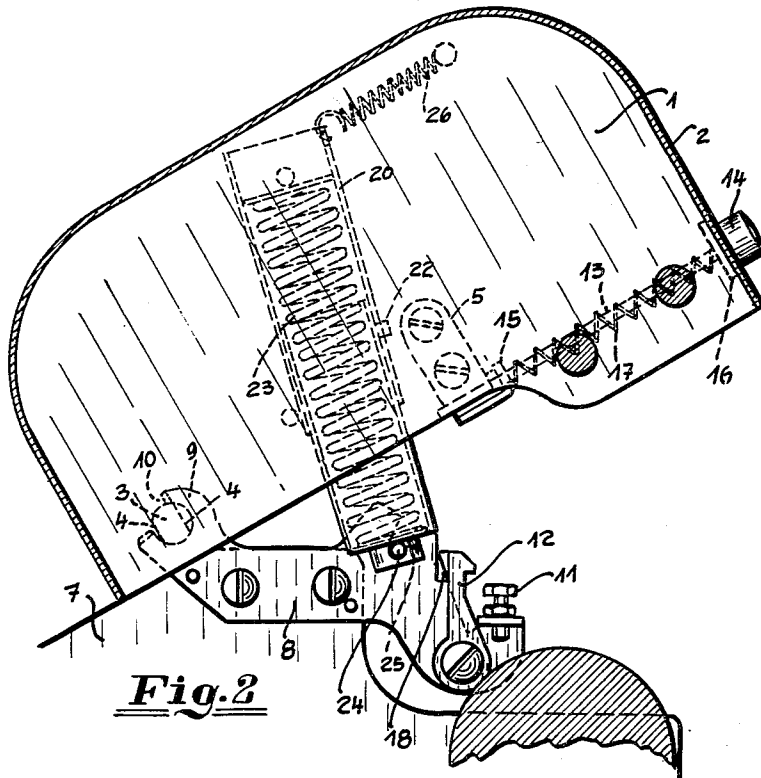

Fig. 2

1

2,766,867

MOUNTING OF FRONT FEED DEVICE FOR BUSINESS WRITING MACHINES

Andreas Salzberger, Frankfurt am Main, Germany, assignor to Torpedo-Werke Aktiengesellschaft Fahrrader und Schreibmaschinen, Frankfurt am Main Rodeheim, Germany, a German company

Application August 17, 1953, Serial No. 374,742

Claims priority, application Germany August 16, 1952

7 Claims. (Cl. 197—127)

The invention concerns business writing machines provided with front feed devices. These front feed devices consist of hopper guides situated above and in front of the platen for introducing one or more account cards from the front into the paper guide of the platen, in front of the basic sheet already drawn in and remaining in the machine, said basic sheet being inserted into the machine from the rear in the usual way. As a rule, the feed hoppers are mounted on the side plates of the machine carriage in a detachable or upwardly hingeable manner, so as to be able to bring the basic sheet, inserted from the rear, behind the upper press-on rollers and to align it. The invention relates to a new method of pivoting these front feed devices, which enables outward pivoting and also complete removal in a simple manner.

According to the invention, the front feed device is held pivotally on both sides by means of eyes in the side plates of the machine carriage, and is adapted to be locked to the side plates in the working position against spring pressure, so that after release of the locking device, it is pivotally urged to the rear. The springs controlling the front feed device are furthermore preferably formed as coil springs accommodated in telescopic tubes of limited relative extension, the telescopic tubes being pivoted at one end to the side plates of the front feed device carrying the pivots, and at the other end advantageously pivoted detachably to the side plates of the machine carriage. The locking device may consist of noses mounted on the side plates of the front feed device, co-operating with spring-loaded locking hooks which are provided on the side plates and which, in the working position of the front feed device engaging over the noses, and can be moved out of engagement with the noses by push rods on the side plates of the front feed device.

By operating the push rods, which for this purpose are provided with push buttons projecting beyond the cover edge of the side plates of the front feed device, the locking device is thus released, and the telescopic tubes, extended by the springs therein, turn the front feed device to the rear a distance controlled by the limited relative extension of the tubes. On the front feed device being brought forward into the position of use, the locking hooks engage again and hold the device fast. The noses lie on adjustable end stops associated with the locking hooks, thus limiting the path of pivoting of the front feed device.

The pivots are provided with flattened portions and the bearing eyes receiving them are provided with slots corresponding to the flattened portions, said slots being so arranged that, after detaching the telescopic tubes from the machine carriage, the front feed device can be turned further to the rear, so that the flattened portions coincide with the slots, in which position the front feed device can be lifted off without difficulty.

The above, and other features and advantages of the invention, are explained more fully with reference to the accompanying drawings showing an embodiment of the invention, and wherein:

2

Fig. 1 shows one of the side plates of the front feed device in the working position.

Fig. 2 shows the device on its inoperative position.

The front feed device, not shown, is carried at its opposite sides by the side plates 1 each provided with a bent-over edge 2 for covering the working parts. Each side plate 1 carries a pivot pin 3, flattened at opposite faces 4, which pivot pins 3 may also be parts of a rod connecting the two side plates 1. Furthermore, secured to each side plate 1 is a strip 5 which is bent over at the lower edge of the plate to form a locking nose 6.

The side plates 7 of the machine carriage each carry a bracket 8 provided at its rear end with an open eye 9 for receiving the pin 3. The insertion slot 10 of the eyes 9 corresponds in width to the distance apart of the flattened faces 4, so that therefore, when the pins 3 are in a certain position with respect to the eyes 9, the pins can be inserted in, or removed from, the related eyes.

The forward pivoting of the side plates 1 on the machine carriage is limited by adjustable stop pins 11 on the brackets 8, and on which the noses 6 are adapted to rest. To secure the side plates 1 in the working position of the front feed device, locking hooks 12 are pivoted to the bracket 8, said locking hooks being loaded by springs not shown, and engaging over the noses 6 in the working position of the front feed device.

For releasing the locking hooks 12, push rods 13 are provided, each of said push rods being carried at one end by means of an operating button 14 extending slidably through an opening in the edge 2 of the related side plate 1, and at the other end in an upwardly bent eye 15 of the related nose 6. The push rods 13 are held in the basic position by means of springs 17 mounted thereon and bearing against the eyes 15 and against a collar 16 of the buttons 14. When the buttons 14 are pressed rearwardly, the rods 13 bear against upwardly bent lugs 18 on the locking hooks 12, which are thereby swung outwardly for releasing the noses 6.

In order to effect automatic turning over of the front feed device with the release of the noses, there is pivoted to each side plate 1 on a pin 19, the outer sleeve 20 of a telescopic tube, in which an inner sleeve 21 can be telescoped to a limited extent. The inner sleeve 21 is provided with a pin 22 passing through a slot in the outer sleeve 20. Accommodated in both sleeves 20, 21 is a coil spring 23, the purpose of which is to hold the sleeves 20, 21 in a relatively extended position (Fig. 2).

The inner sleeve 21 carries a radial pin 24, engaging an open slot 25 of the bracket 8. A tension spring 26 mounted between the outer sleeve 20 and the side plate 1 urges the sleeves 20, 21 angularly about the pin 19 in such a direction that the pin 24 is held in the slot 25.

For removing the front feed device, in the position shown in Fig. 2, the sleeves 20, 21 are turned by hand against the action of the spring 26, so that the pin 24 is lifted out of the slot 25. The front feed device can thus be turned over about the pivot 3 until the flattened portions 4 coincide with the insertion slot 10, in which position the device can be drawn off or inserted. On pivoting the front feed device toward the position of Fig. 2, after the pivot pins 3 have been again engaged in the eyes 9, the pins 24 then automatically catch in the slots 25.

I claim:

1. In a business machine having a carriage, an arrangement for hingedly mounting a front feed device on the side plates of the carriage; said arrangement comprising side plates on the front feed device, pivot pins extending from the side plates of the front feed device adjacent the back of the latter, mounting brackets on the side plates of the carriage having eyes for receiving said pivot pins so that the front feed device is turnable rear-

3

wardly about said pivot pins from a working position, spring actuated means for urging the front feed device to turn rearwardly about said pivot pins from said working position, noses projecting from said side plates of the front feed device at locations spaced forwardly from said pivot pins, locking hooks rockably mounted on the side plates of the carriage and engageable with said noses to hold the front feed device in its working position against the action of said spring actuated means, and push-rods slidably mounted on said side plates of the front feed device and projecting from the latter, said push-rods being engageable with said locking hooks to rock the latter out of engagement with said noses in response to actuation of said push-rods so that said spring actuated means are then free to turn the front feed device rearwardly from said working position thereof.

2. The combination according to claim 1; wherein said side plates of the front feed device have laterally bent edges, at least at the front thereof, formed with openings, said push-rods having actuating buttons on the forward ends thereof extending slidably through said openings and formed with collars engageable with said bent edges around said openings to limit the forward movement of said push-rods, said noses having guide passages therein slidably receiving the rear ends of said push-rods, and a coil-spring around each of said push-rods between the related one of said noses and said collar to yieldably urge said push-rods forwardly out of engagement with the related locking hooks.

3. The combination according to claim 1; wherein said spring actuated means includes two slidably telescoping tubes having a coil spring therein operative to urge said tubes to a relatively extended position, means pivotally connecting said telescoping tubes, at one end, to the related side plate of the front feed device, and means pivotally connecting the other end of said telescoping tubes to the adjacent side plate of the carriage.

4. The combination according to claim 3; further comprising means limiting the relative extension of said tele-

4

scoping tubes; and wherein said means pivotally connecting said other end of the tubes to the adjacent side plate of the carriage includes a radial pin projecting from said other end of the telescoping tubes, said mounting brackets having slots therein opening generally toward the front to receive said radial pins of the adjacent telescoping tubes, and spring means acting on said telescoping tubes to swing the latter in the direction urging said radial pins rearwardly in said slots thereby to prevent inadvertent removal of said radial pins from the slots.

5. The combination according to claim 1; wherein said pivot pins have diametrically opposed flattened sides, and said eyes have openings with the distance across said openings corresponding substantially to the width of said pivot pins between said flattened sides to permit said pivot pins to pass through said openings during the insertion and removal of the pivot pins with the front feed device in a predetermined position turned rearwardly from said working position.

6. The combination according to claim 5; wherein said spring actuated means includes slidably telescopic tubes having spring means therein to urge said tubes to a limited extended position, means pivotally connecting said tubes, at one end, to said side plates of the front feed device, and means for pivotally and removably connecting said tubes, at the other end thereof, to the related side plates of the carriage.

7. The combination according to claim 1; further comprising adjustable stop members on said mounting brackets engageable by said noses during forward turning of the front feed device thereby to limit such forward turning at said working position.

References Cited in the file of this patent

UNITED STATES PATENTS

2,127,798	Wittenmyer	Aug. 23, 1938
2,139,095	Pfeiffer	Dec. 6, 1938
2,649,950	Endrich	Aug. 25, 1953